

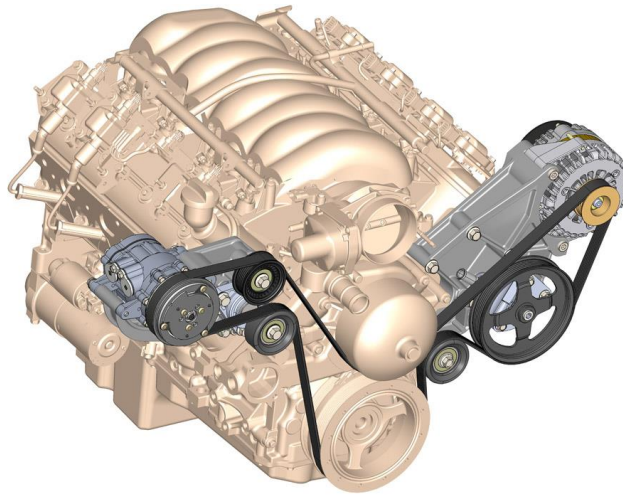

# Holley Accessory Drive System

## Part Number 20-138



### Table of Contents

Introduction: .....	2
Crank Pulley Belt Alignment Determination: .....	3
Overview of Parts Required (but NOT included with 20-138 accessory drive system): .....	3
Water Pump Determination: .....	4
Parts List: .....	7
Assembly Instructions .....	9
Driver's Side Bracket Installation: .....	9
Power Steering Pump Installation: .....	10
Idler Pulley Installation (position options): .....	11
Power Steering Pump Pulleys: .....	12
Small Diameter Pulley: .....	12
P/S Pulley & Alternator Installation: .....	13
Passenger's Side Bracket Installation: .....	14
Idler & Tensioner Installation: .....	15
A/C Compressor Installation: .....	16
Belt Routing: .....	17
Power Steering Pump Reservoir Options: .....	18

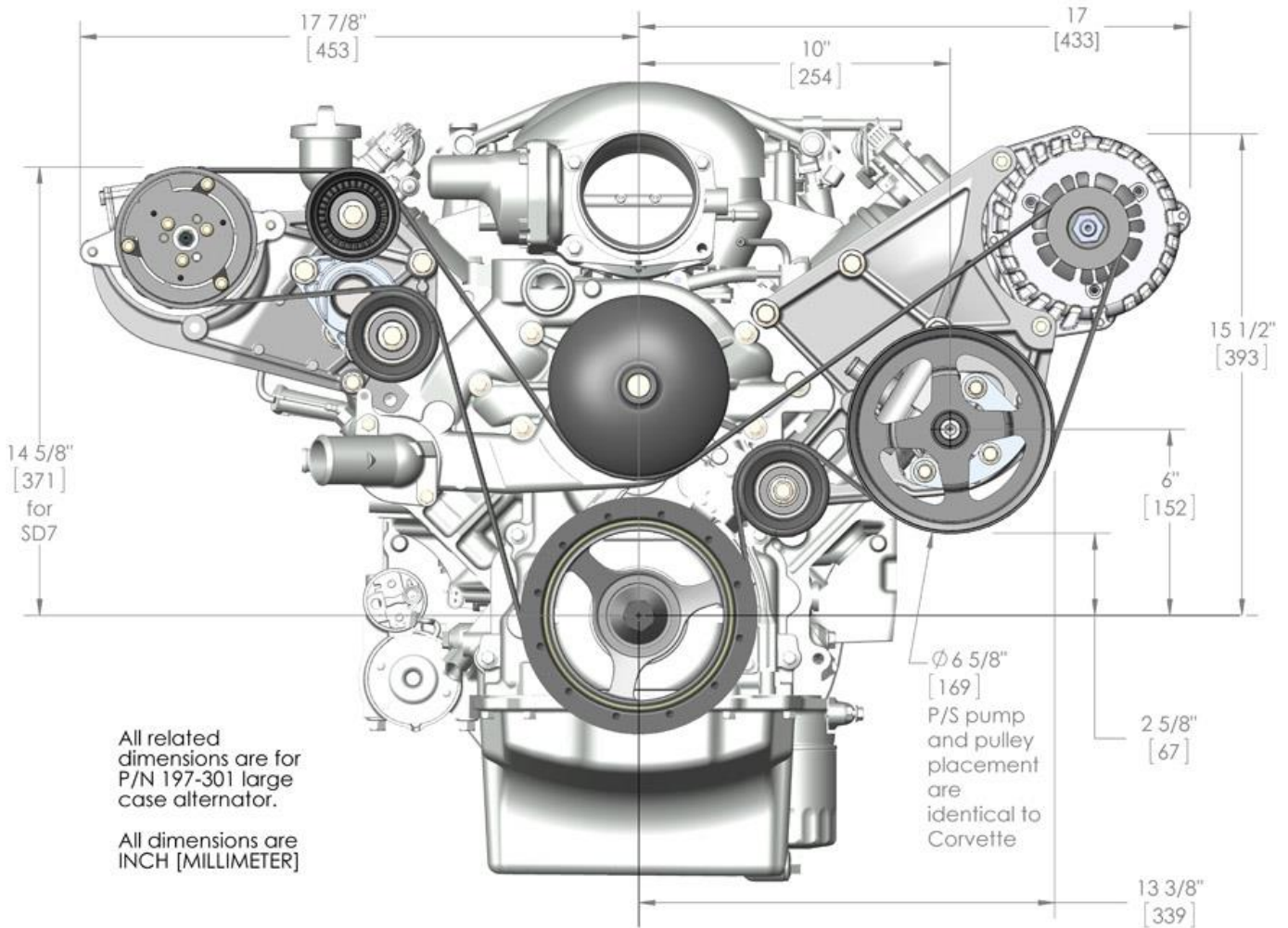

## Introduction:

Holley's accessory drive systems offer clean, economical brackets and accessories for LS engines. These accessory drives look truly at home on any LS engine as if they came from the factory this way.

Holley's complete accessory drive systems come with virtually everything needed for installation, from the accessories to the pulleys and even the belt.

The first step is to determine which belt alignment you want to proceed with. This is determined by the crank pulley and often, but not always, the water pump. If clearance to the radiator is an issue, the compact STANDARD spacing common on the Corvette may be preferred. Otherwise, it is most cost effective to retain the existing crank pulley/water pump and space the bracket and other accessories to match. **An application specific installation kit (part # 21-1, 21-2, or 21-3) is REQUIRED for this accessory drive system.**

## Crank Pulley Belt Alignment Determination:

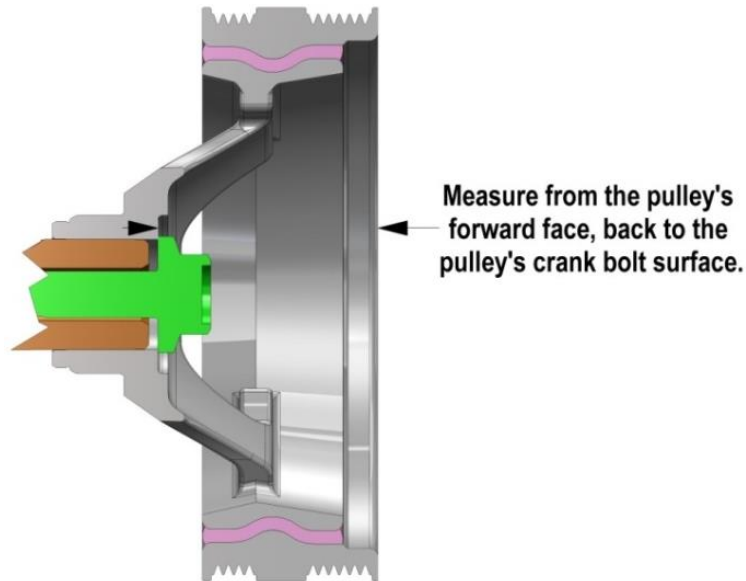

See the below chart for reference dimensions.

## Overview of Parts Required (but NOT included with 20-138 accessory drive system):

### Components with specific belt alignments

Belt Alignment Group	LS Application (Alignment Specific)	Holley Installation Kit (Alignment Specific)	Crank Pulley (Reference Dimension)		Water Pump (Alignment Specific)
					GM #
Standard	Corvette / CTS-V / G8	21-1	1.5"	37 MM	19256263, 89018052, or 12604630
Middle	F-body / GTO	21-2	2.25"	55 MM	19256263
Long	Camaro ('10-UP) / Truck (all)	21-3	3"	75 MM	19207665 or any truck WP

## Water Pump Determination:

To determine which water pump type you have, refer to the following illustrations:

**LS1/LS2/LS6 wide pulley water pump**  
Works with **STANDARD** and **MIDDLE** belt spacings

GM P/N 19256263  
'97-'04 Corvette  
'04-'05 CTS-V  
'98-'02 Camaro/Firebird  
'04-'06 GTO

This round boss may not be present on this water pump

Identifying feature:  
Wide pulley allowing for both standard and middle belt spacings

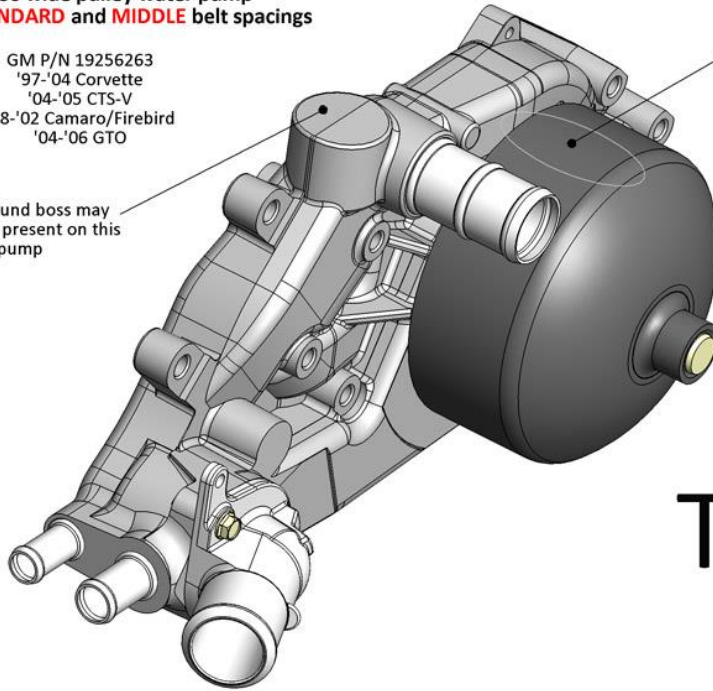

**TYPE  
1**

**LS2 Specific water pump**  
Works with **STANDARD** belt spacing

GM P/N 89018052  
'05-'07 Corvette  
'06-'07 CTS-V

Identifying features:  
Narrow pulley and passenger's side outlet

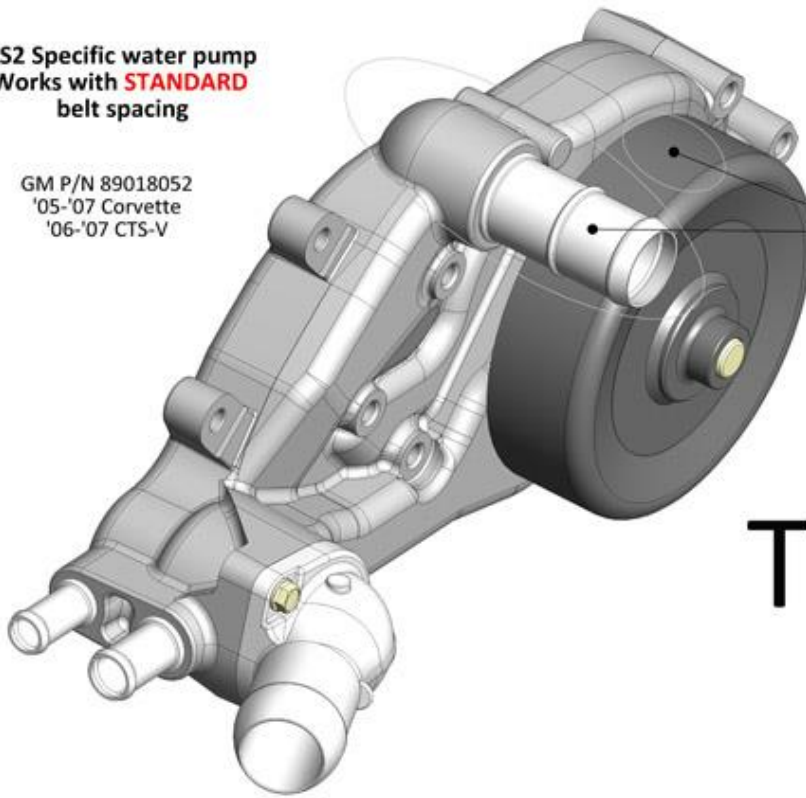

**TYPE  
2**



**LS3 Corvette/G8 water pump**  
Works with **STANDARD**  
belt spacing

GM P/N 12604630  
'08-UP Corvette  
'08-'09 G8

Identifying feature:  
Driver's side outlet

**Bracket Bolt Access**

Either the water pump will need to be installed after the bracket or the area in red will need to be removed for bracket/spacer access. Remove the material so the boss shape is similar to that of the boss on water pump TYPE 1, 2, or 5. Otherwise, the bolt will not pass by the boss.

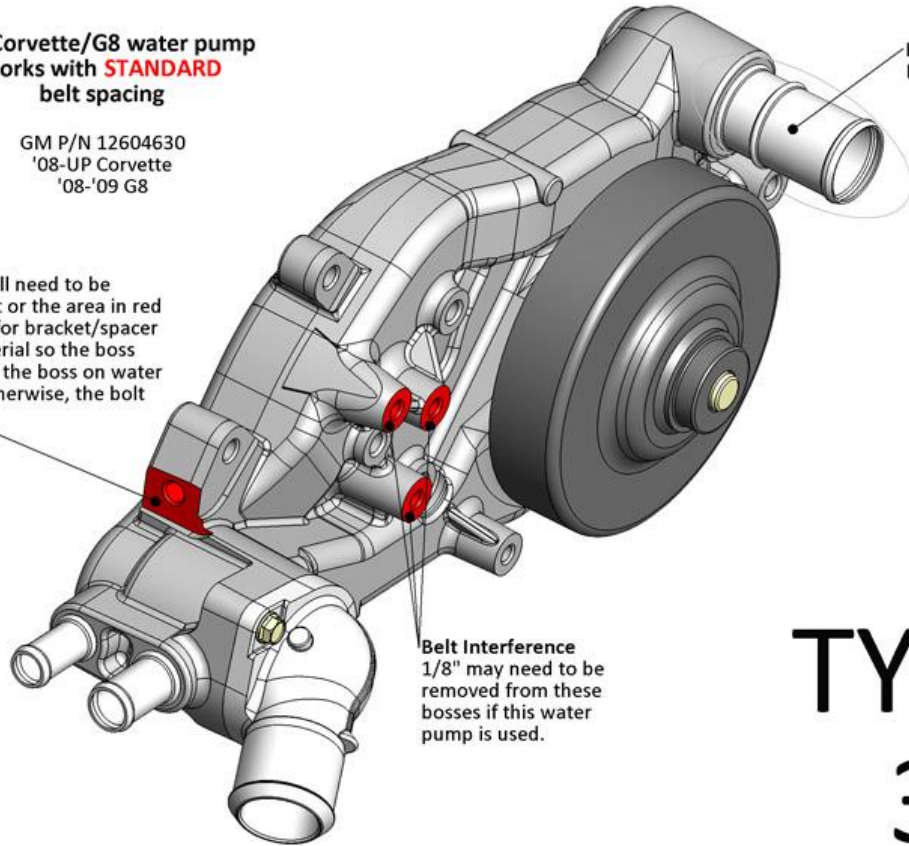

**TYPE  
3**

**LS3/L99 Camaro water pump**  
Works with **LONG** belt spacing

GM P/N 19207665  
'10-UP Camaro

Identifying feature:  
Long tensioner Bosses

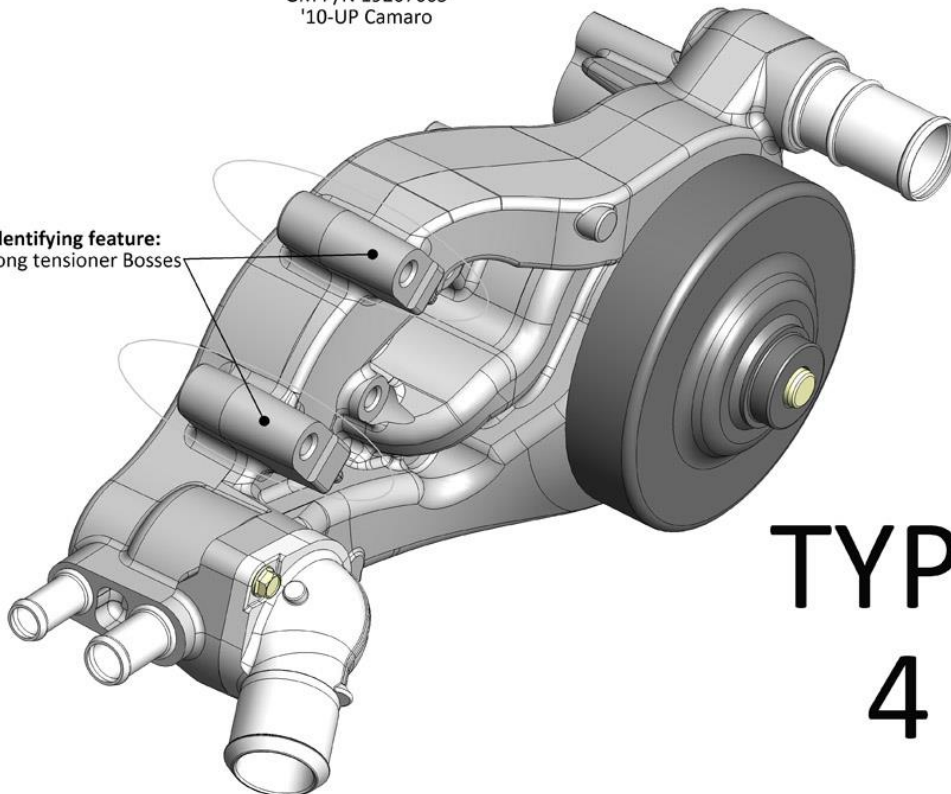

**TYPE  
4**

**TRUCK water pump**  
Works with **LONG** belt spacing

GM P/N (Numerous)  
All truck LS based engines

Identifying feature:  
Upward pointing  
inlet

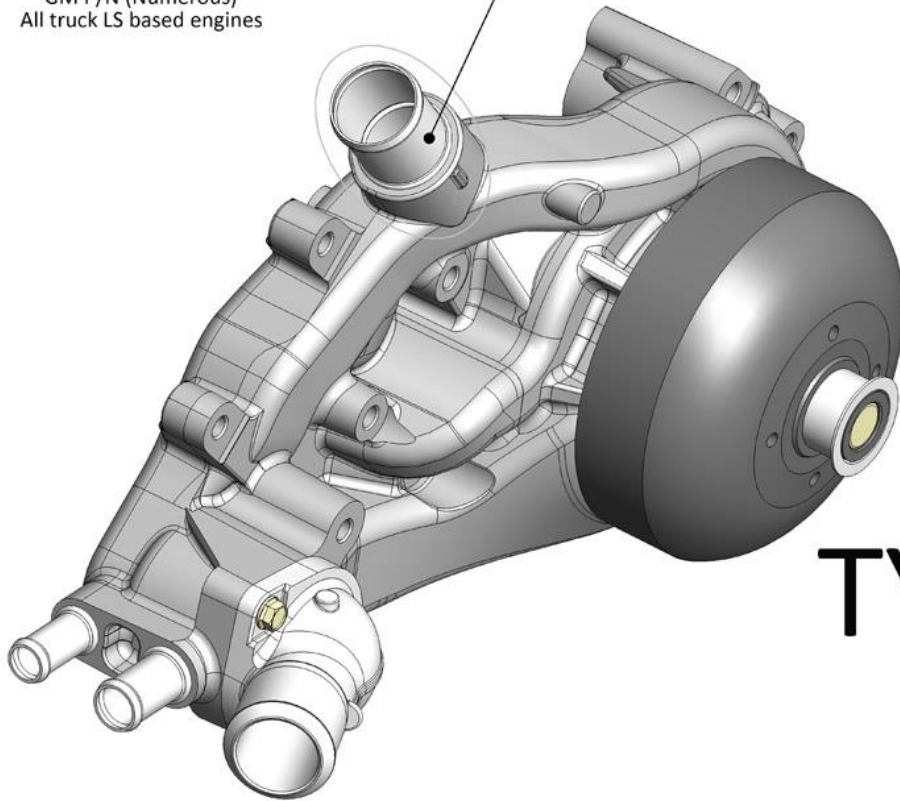









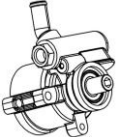
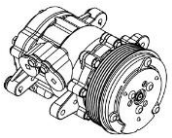

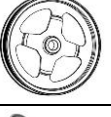

**TYPE**  
**5**

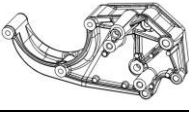
## Parts List:

This accessory drive system requires application specific installation kit part # 21-1, 21-2, or 21-3

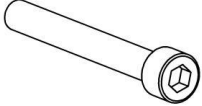
**Parts included with 20-138 accessory drive system (see list supplied with installation kit for additional parts):**

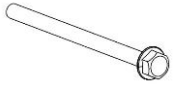
PICTURE	QTY	DESCRIPTION	APPLICATION
	1	Alternator (P/N 197-301)	Driver's Side Bracket
	1	P/S Pump (P/N 198-100)	Driver's Side Bracket
	1	SD7 A/C Compressor (P/N 199-102)	Passenger's Side Bracket
	1	Belt Tensioner with Bolt (P/N 97-151)	Passenger's Side Bracket
	2	Smooth Idler Pulley (P/N 97-150)	Driver's & Passenger's Side Brackets
	1	Ribbed Idler Pulley, 68mm	Passenger's Side Bracket
	1	Pigtails (P/N 197-400)	Alternator
	1	Ribbed Pulley (P/N 97-152)	P/S Pump
	1	Belt, 6 Rib Serpentine	Driver's & Passenger's Side Brackets
	1	Driver's Side Bracket Assembly	Alternator & Power Steering Pump
	1	Passenger's Side Bracket Assembly	A/C Compressor & Tensioner
	1	Power Steering Pump Plate Bracket	Front Support of Power Steering Pump

	1	Step Spacer	Driver's Side Idler Pulley
	1	Socket Head Cap Bolt, M10 x 1.5 x 30	Spacer to Passenger's Side Head
	2	Socket Head Cap Bolt, M10 x 1.5 x 80	Alternator Bolts
	2	Flange Head Bolt, M8 x 1.25 x 20	Power Steering Pump Bolts
	2	Flange Head Bolt, M8 x 1.25 x 80	Power Steering Pump Bolts
	3	Flange Head Bolt, M8 x 1.25 x 35	Passenger's Side Bracket to Spacer
	2	Flange Head Bolt, M10 x 1.5 x 35	Tensioner Assembly to Passenger's Side Bracket
	1	Flange Head Bolt, M10 x 1.5 x 35	Idler Pulley to Passenger's Side Bracket
	1	Flange Head Bolt, M10 x 1.5 x 45	Idler Pulley to Driver's Side Bracket
	2	Flange Head Bolt, M8 x 1.25 x 95	A/C Compressor Bolts
	2	M8 Thin Spacer	Bracket to Front A/C Compressor Ears



# Assembly Instructions

## **Driver's Side Bracket Installation:**

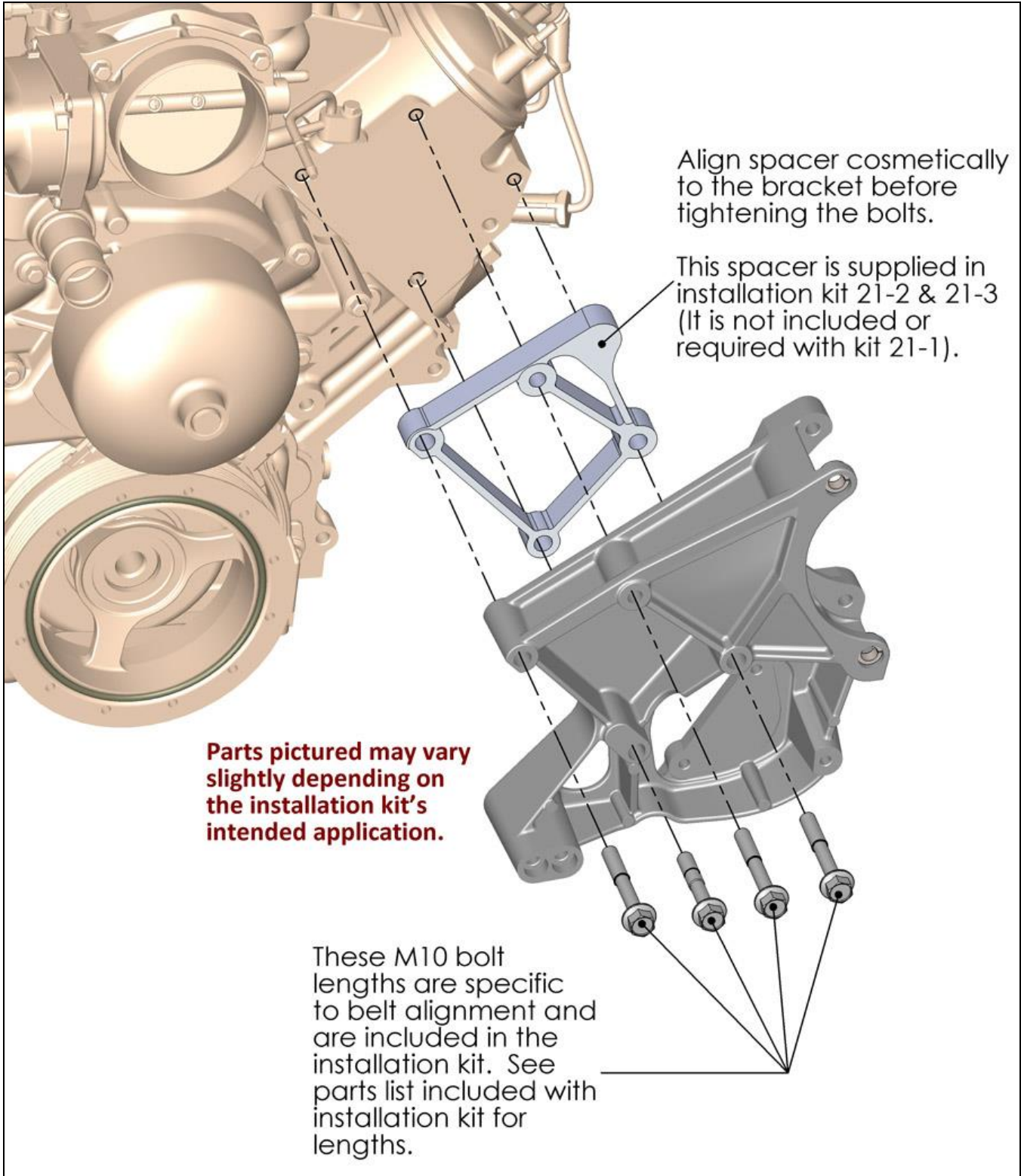

**NOTE:** Torque M8 bolts to 18 ft./lbs. and M10 bolts to 36 ft./lbs.

## Power Steering Pump Installation:

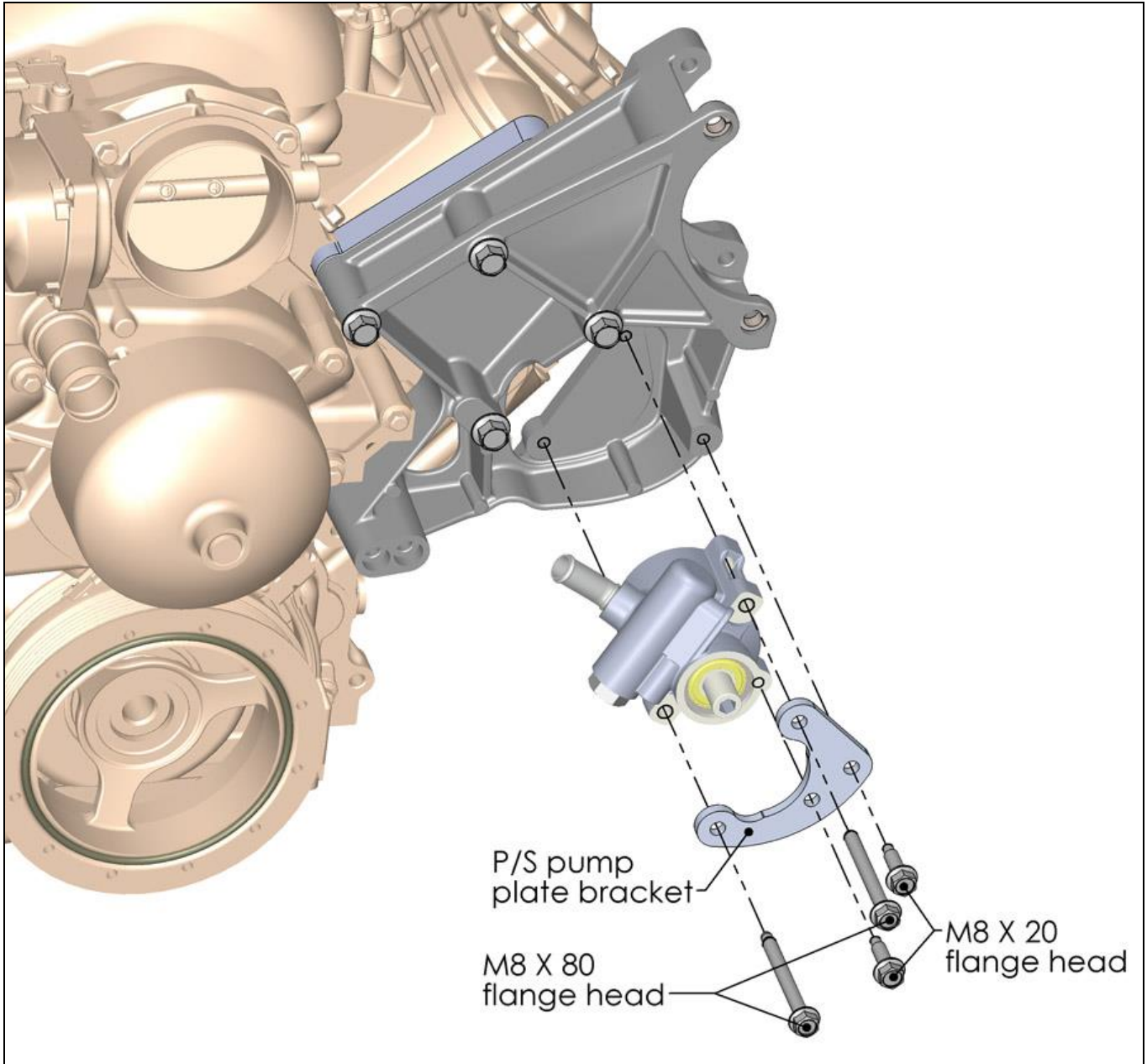

**NOTE:** Torque M8 bolts to 18 ft./lbs. and M10 bolts to 36 ft./lbs.

## Idler Pulley Installation (position options):

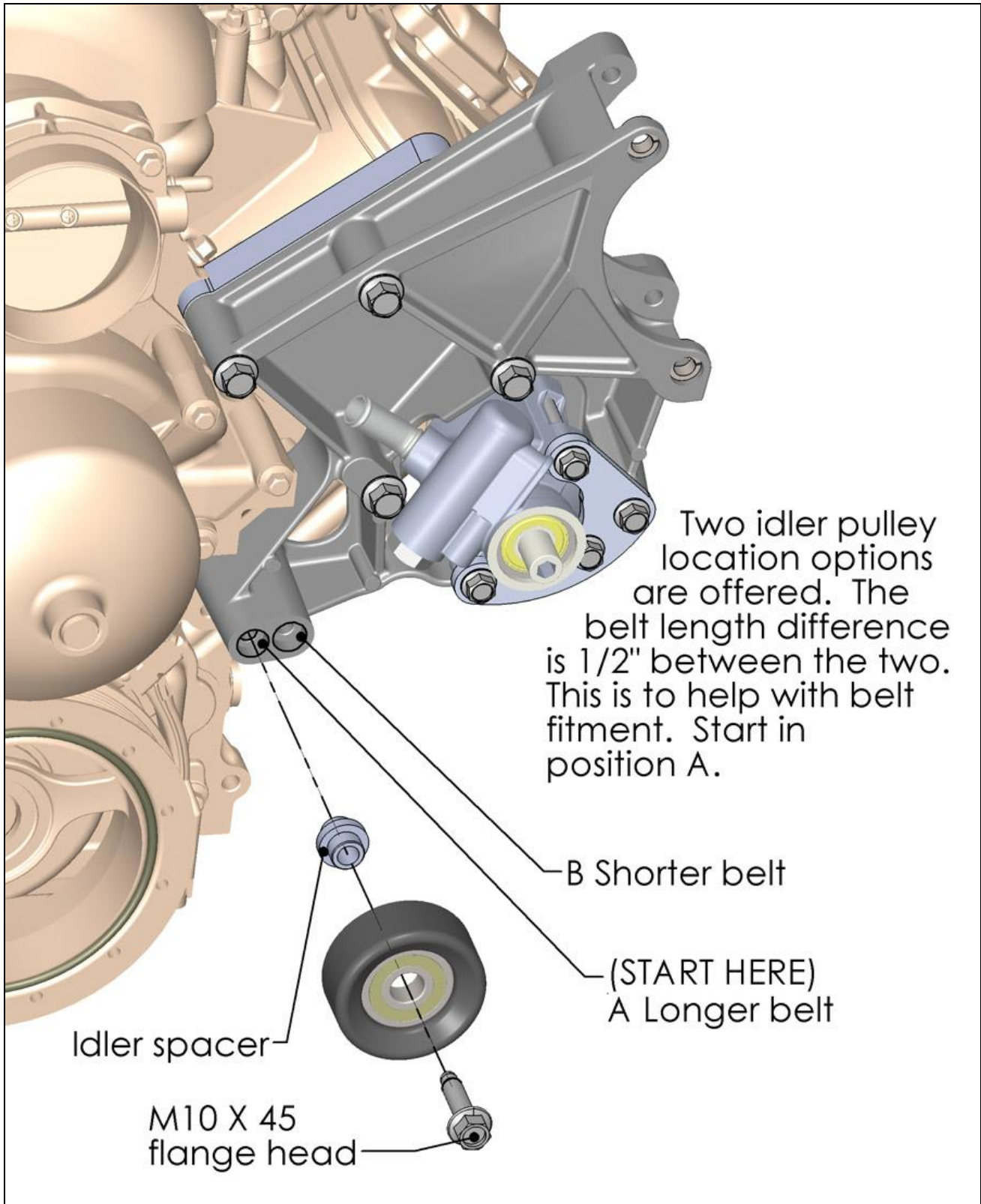

**NOTE:** Torque M8 bolts to 18 ft./lbs. and M10 bolts to 36 ft./lbs.



## Power Steering Pump Pulleys:



NOTE: If using AN fittings on the pressure line, Holley P/N 961961ERL AN extension/adaptor is required.

There are several pulleys that will fit the pump, but some do not have the correct belt alignment for this application. See applicable service manual for pulley installation procedures.

### Small Diameter Pulley:

Power steering pulleys may interfere with the suspension A-arm in certain swap applications. Choosing a smaller pulley in these situations can give additional clearance.



Power steering pump pulley
Holley P/N 97-154
OD to grooves: 5.45"
OD overall: 5.75"

**WARNING! Smaller power steering pulleys, such as a 97-154 can rotate the pump beyond recommended RPMs. To correct this, a 25% under-dive balancer should be used if choosing a pump pulley smaller than 6" OD.**

Belt Alignment Group	LS Application (Alignment Specific)	Balancer (25% under-drive)
		Powerbond P/N
Standard	Corvette/CTS-V/G8	PBU1117SS25
Middle	F-body/GTO	PBU1480SS25
Long	Camaro ('10-UP)/ Truck (all)	PBU1190SS25

**Helpful Hint:** If any of these smaller pulleys are used, the supplied belt will not work and a shorter size will have to be purchased at an auto parts store.

## ***P/S Pulley & Alternator Installation:***

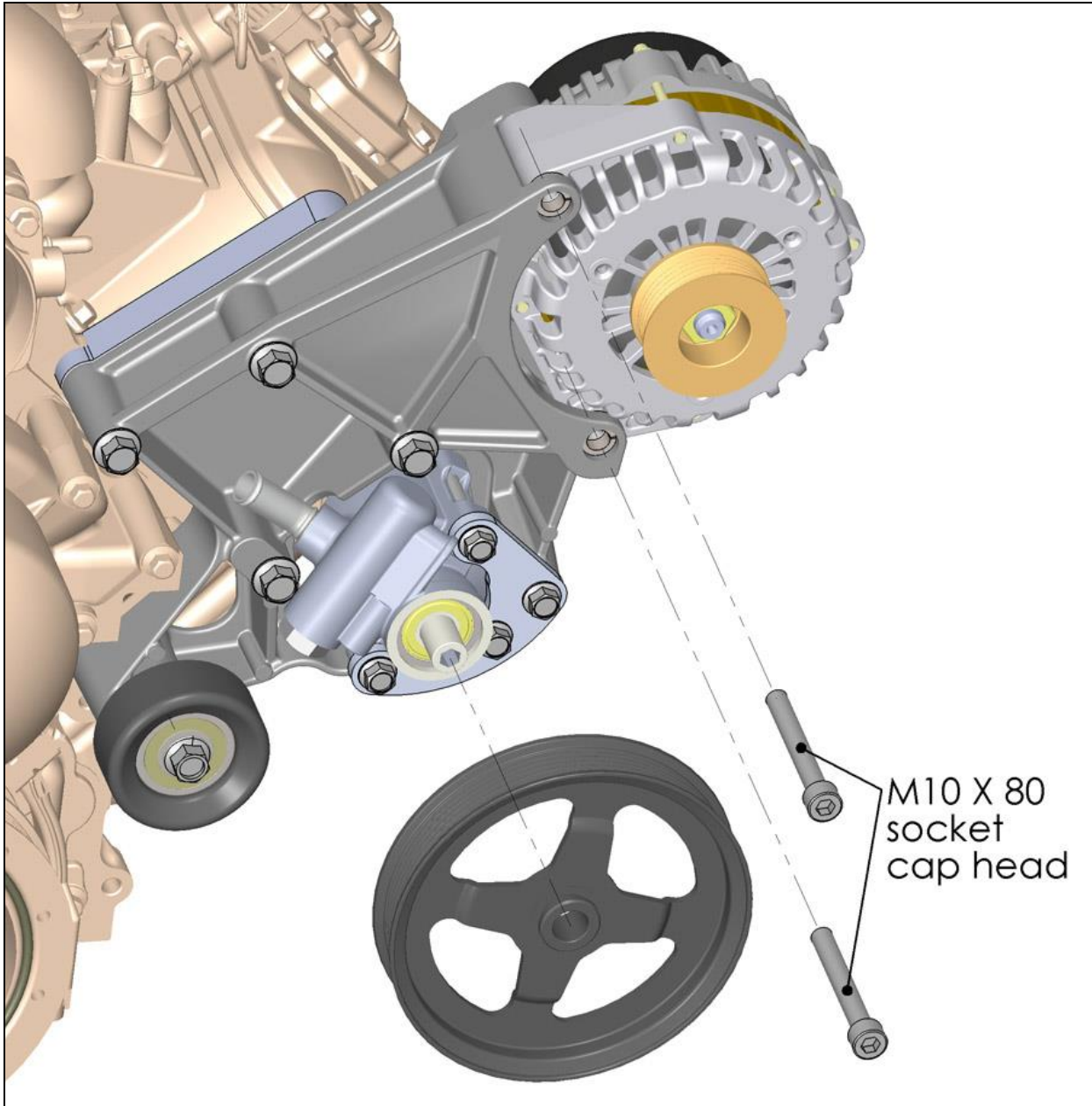

**NOTE:** Torque M8 bolts to 18 ft./lbs. and M10 bolts to 36 ft./lbs.

The P/S pulley must be installed using an installation tool that can be rented at most auto parts stores. Incorrect installation of this pulley may damage the P/S pump internals. When installed, the pulley bore face should be flush with the end of the pump shaft.

**Helpful hint:** Open faced pulley part 97-152 (included) can be installed onto pump before bracket assembly as bolts can be accessed through pulley windows.

**Helpful hint:** When wiring the alternator, install the included 197-400 plug into the alternator. Next connect the yellow wire to switched voltage that is “on” when the key is in the run position. If the vehicle has a “charge indicator light” the yellow wire can be connected to that circuit.

## Passenger's Side Bracket Installation:

If the EVAP solenoid is located on the front of the passenger's side head, it will need to be relocated when using this A/C compressor bracket.

Parts pictured may vary slightly depending on the installation kit's intended application.

This spacer is not supplied with the bracket, but is required for installation on all applications. This spacer is supplied in the installation kit 21-1, 21-2, and 21-3.

Align spacer cosmetically to the bracket before tightening the bolts.

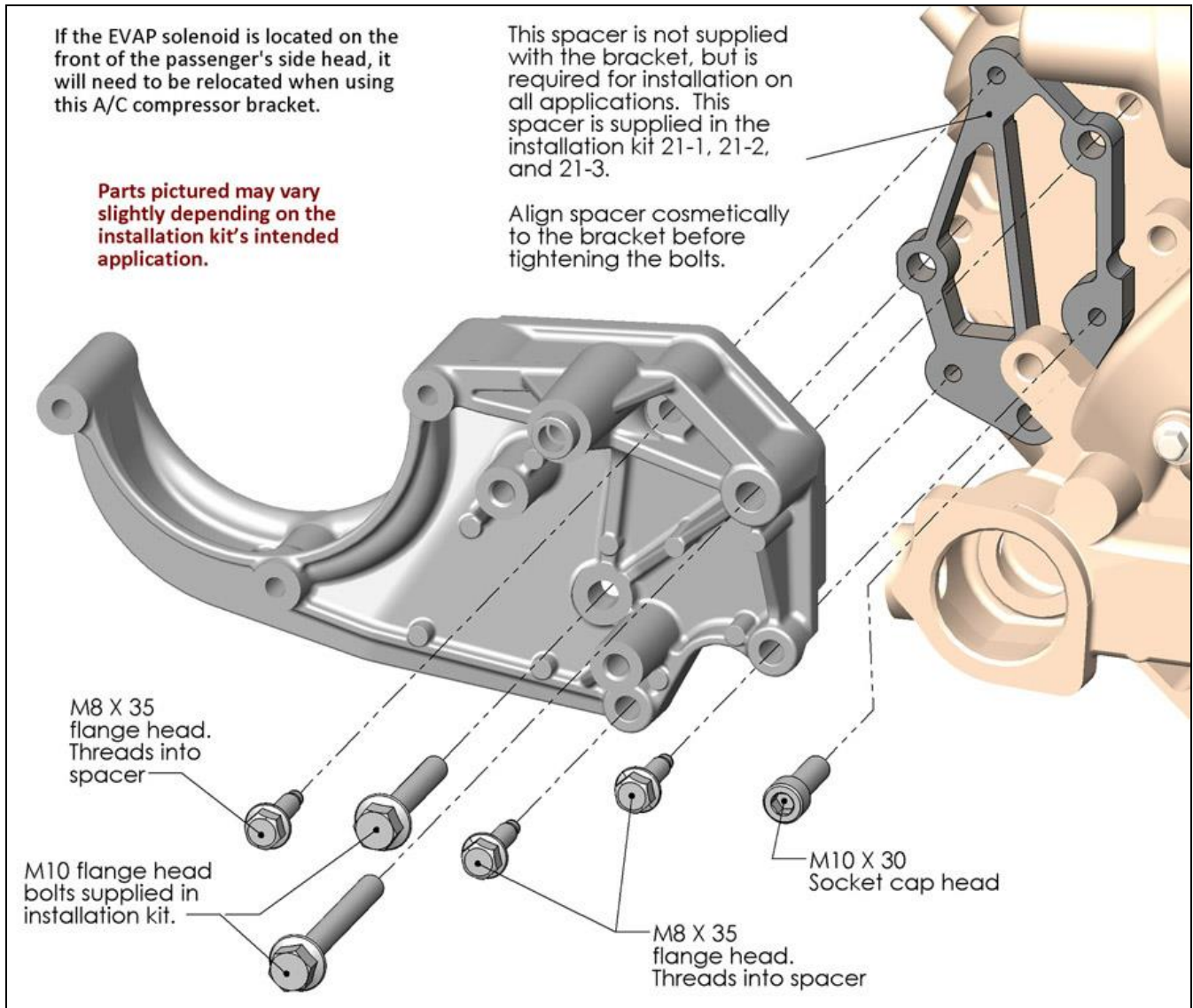

**NOTE:** Torque M8 bolts to 18 ft./lbs. and M10 bolts to 36 ft./lbs.



## Idler & Tensioner Installation:

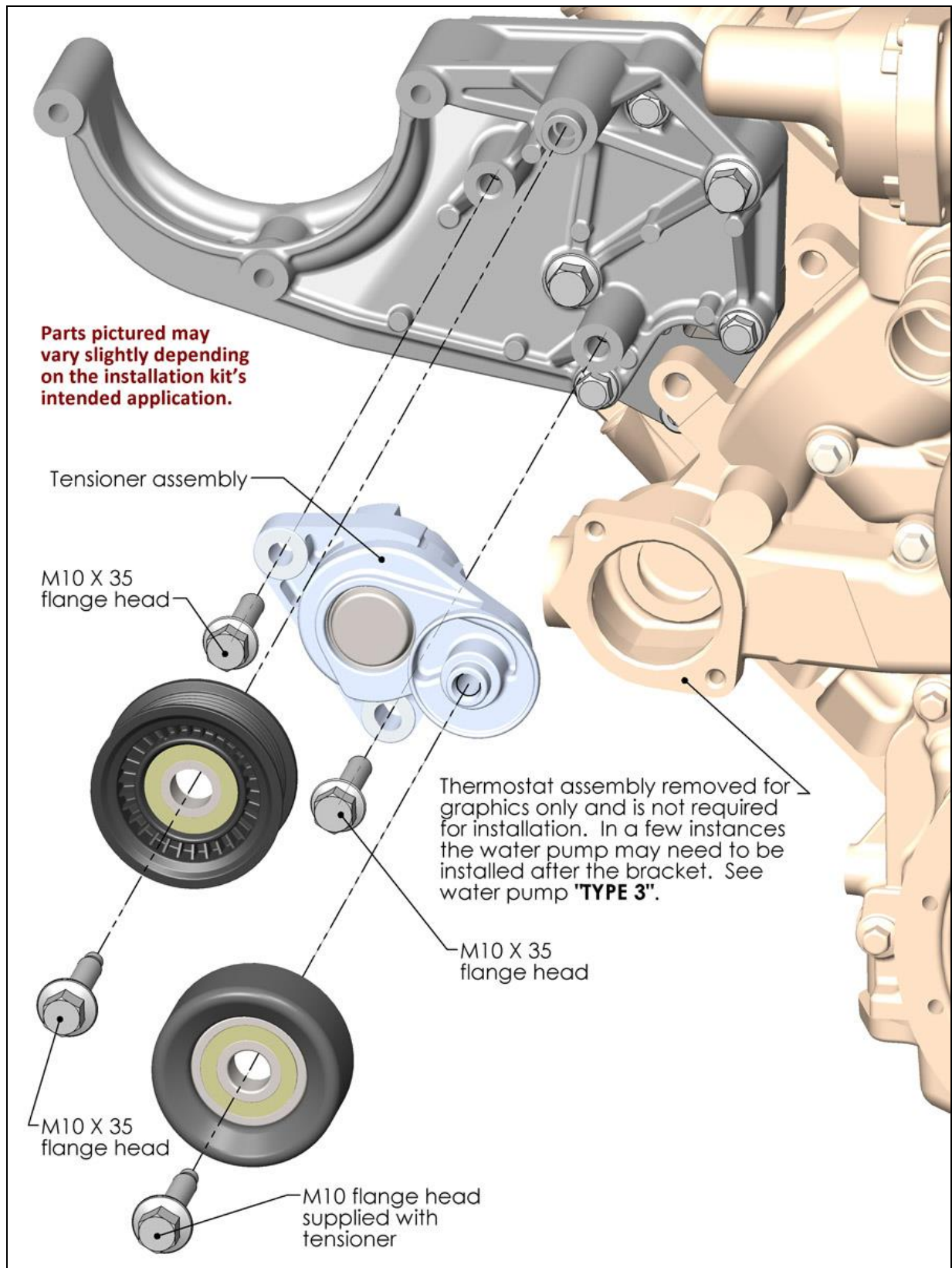

**NOTE:** Torque M8 bolts to 18 ft./lbs. and M10 bolts to 36 ft./lbs.

## A/C Compressor Installation:

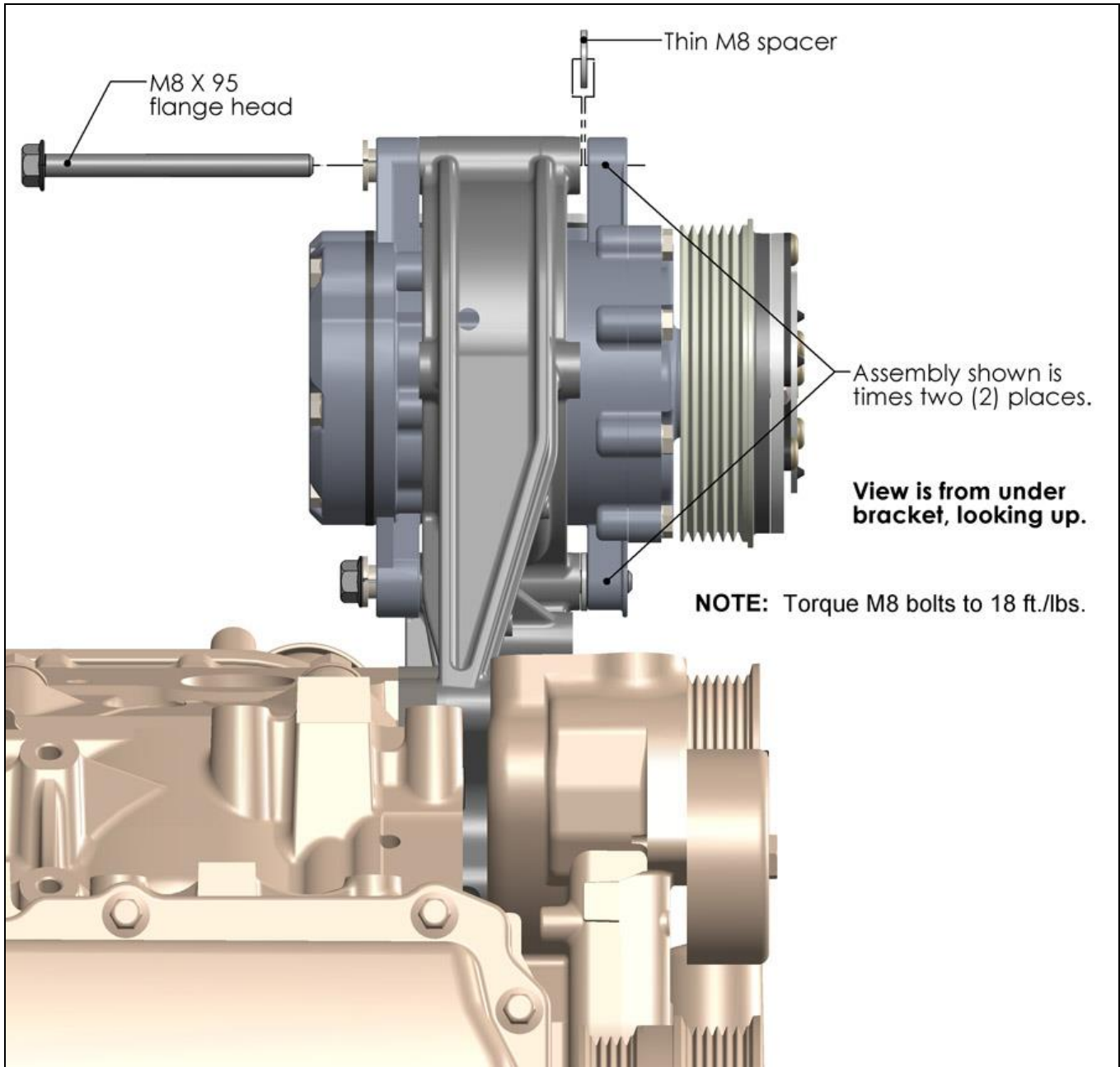

## **Belt Routing:**

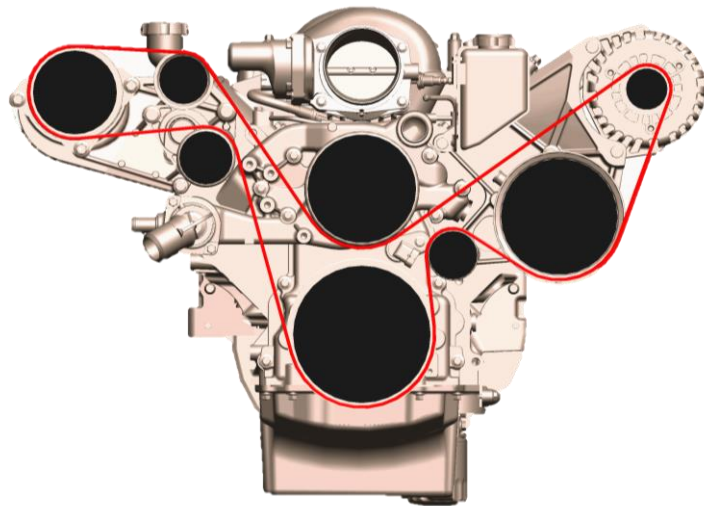

**HELPFUL HINT:** When installing the belt, route around all the pulleys except the water pump pulley. While fully rotating the tensioner arm, slip the belt on the smooth water pump pulley last.

Use serpentine belt supplied if using ALL Holley accessories and supplemental parts.

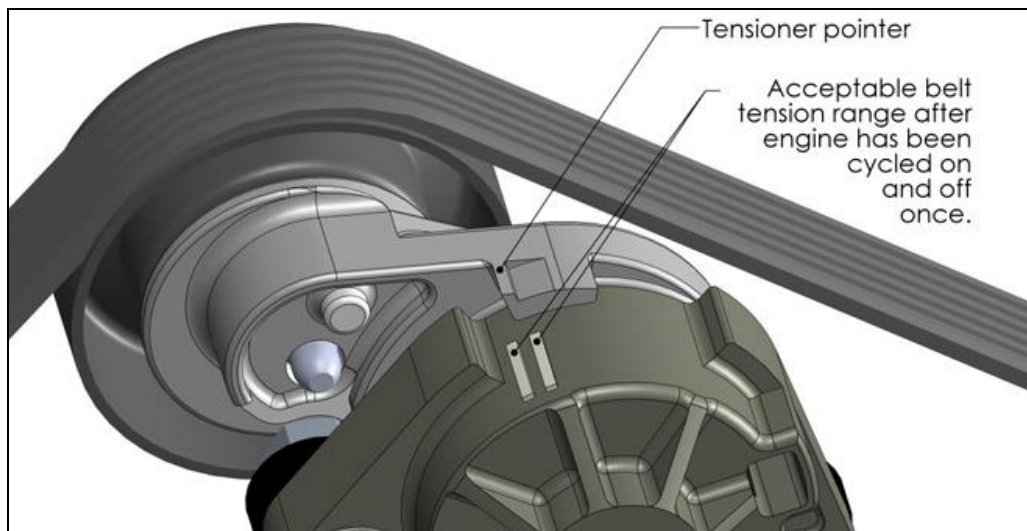

**NOTE:** If you are NOT using all the Holley accessories supplied, or have changed the original crank or any accessory's pulleys, you will have to measure to find the correct belt length.

To acquire this measurement, perform the following:

After all brackets and accessories are installed, route masking tape or string around the belt path. Leave the tensioner in the un-sprung position for this measurement. Mark or cut the tape/string to length and remove from the pulleys. Subtract 1 1/8" (28 mm) from the measured length to compensate for the un-sprung tensioner position. You will need to convert belt length to millimeters if measured in inches (inches X 25.4 = mm). Go to any auto parts store and ask for a 6PK0000 belt with the "0000" being the length in millimeters. For example, if you measured 2493 mm and then subtracted 28 mm, you would get 2465 mm, and the part number would be 6PK2465. Remember, if you miss on size, the driver's side idler can be moved to decrease the required belt length by 1/2".

## **Power Steering Pump Reservoir Options:**

The Holley driver's side bracket works with reservoirs found on '97-up Corvettes. Other remote reservoirs can be custom fitted with this bracket as well. All the below reservoir parts are included in **Holley kit # 198-200**.

