

Fitment and Required Components Guide



Holley Accessory Drive Kit Part Number 20-134

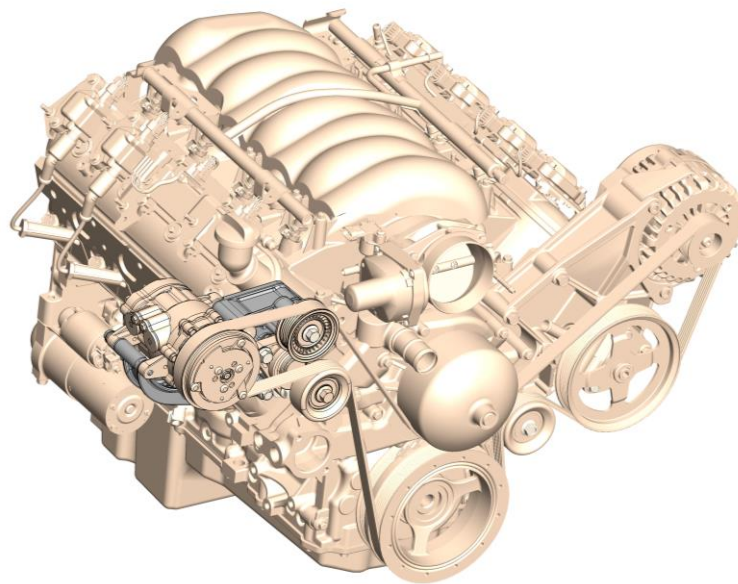
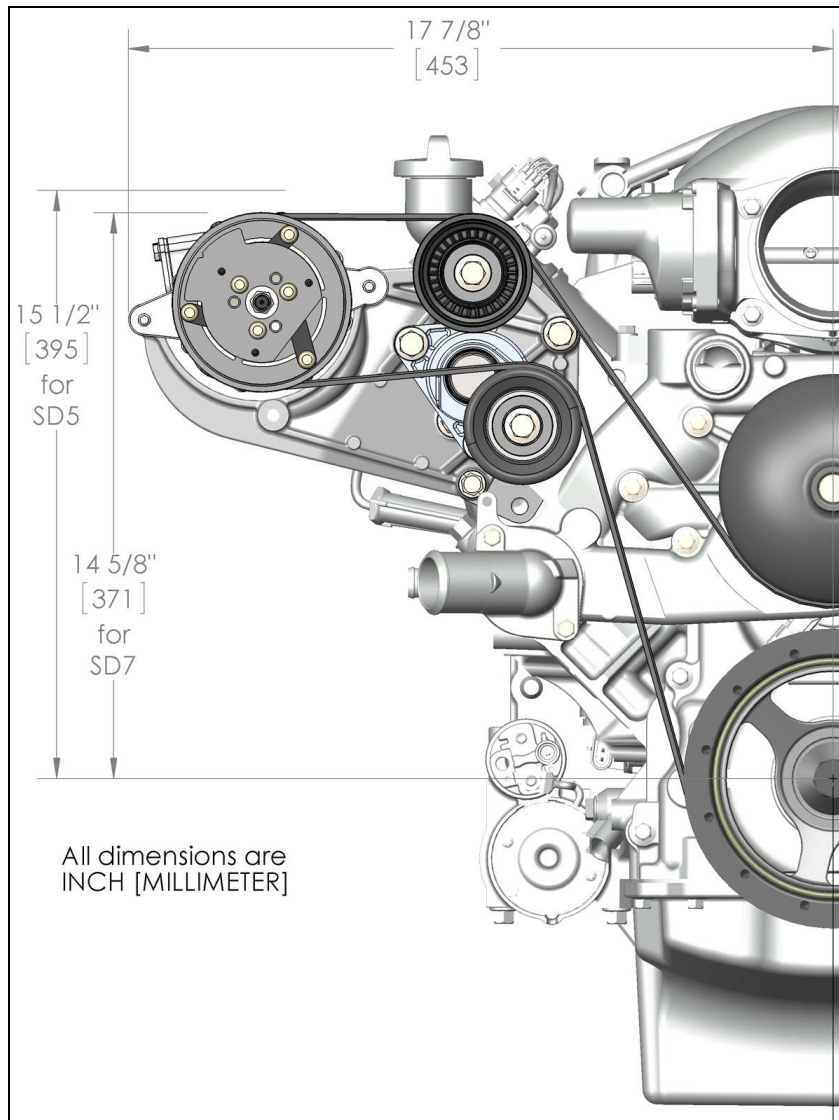

Table of Contents

Introduction:.....	2
Crank Pulley Belt Alignment Determination:.....	3
Overview of Parts Needed (but NOT included with 20-134 bracket kit):	3
Water Pump Determination:.....	4
Idler Pulley Options:	7
Tensioner Assembly Options:	8
A/C Compressors Options and Warnings:	9



Introduction:

Holley's accessory drive kits offer clean, economical mounting of all LS engine accessories. These brackets look truly at home on any LS engine as if they came from the factory this way.

Holley's kits supply the required brackets and hardware needed for installation, but allow you to choose the source for supplemental accessories and components that are often already on the donor engine or the vehicle the engine is going into. Whether sourcing from the salvage yard, the local auto parts store, your GM parts dealer, or Holley and their premium matched components; you pick the source that matches your expectations and budget.

This guide will help with locating and sourcing components, as well as supplying notes and helpful hints for each. The first step is to determine which belt alignment you want to proceed with. This is determined by the crank pulley and often, but not always, the water pump. If clearance to the radiator is an issue, the compact STANDARD spacing common on the Corvette may be preferred. Otherwise, it is most cost effective to retain the existing crank pulley/water pump and space the bracket and other accessories to match. An application specific installation kit (part # 21-1, 21-2, or 21-3) is REQUIRED for ALL bracket kits.

Note: All Corvette part application references in this guide are to NON-supercharged LS engines.

Crank Pulley Belt Alignment Determination:

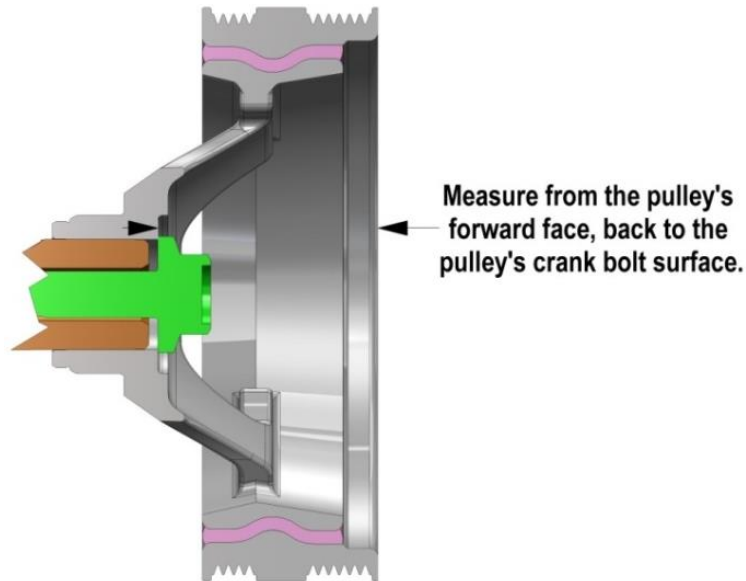

See the below chart for reference dimensions.

Overview of Parts Needed (but NOT included with 20-134 bracket kit):

Components with specific belt alignments

Belt Alignment Group	LS Application (Alignment Specific)	Holley Installation Kit (Alignment Specific)	Crank Pulley (Reference Dimension)		Water Pump (Alignment Specific)	Original Equipment Driver's Side Bracket
					GM #	GM # (Numerous)
Standard	Corvette / CTS-V / G8	21-1	1.5"	37 MM	19256263, 89018052, or 12604630	Most LS driver's side brackets and components can be used with this kit, but only in conjunction with the corresponding alignment's installation kit (21-1, 21-2, or 21-3)
Middle	F-body / GTO	21-2	2.25"	55 MM	19256263	
Long	Camaro ('10-UP) / Truck (all)	21-3	3"	75 MM	19207665 or any truck WP	

Components that will work with all belt alignments

Tensioner Assembly	Smooth Idler Pulley	A/C Compressor (Sanden Types)	Driver's Side Bracket
Holley # / GM #	Holley # / GM #	Holley # / Sanden #	Holley #
97-151 / 12559325	97-150 / 12564401	199-101 / SD508, SD5H14-S6669 & similar OR 199-102 / SD7, SD7B10-7176 & similar	20-135

Water Pump Determination:

To determine which water pump type you have, refer to the following illustrations:

LS1/LS2/LS6 wide pulley water pump
Works with **STANDARD** and **MIDDLE** belt spacings

GM P/N 19256263
'97-'04 Corvette
'04-'05 CTS-V
'98-'02 Camaro/Firebird
'04-'06 GTO

This round boss may not be present on this water pump

Identifying feature:
Wide pulley allowing for both standard and middle belt spacings

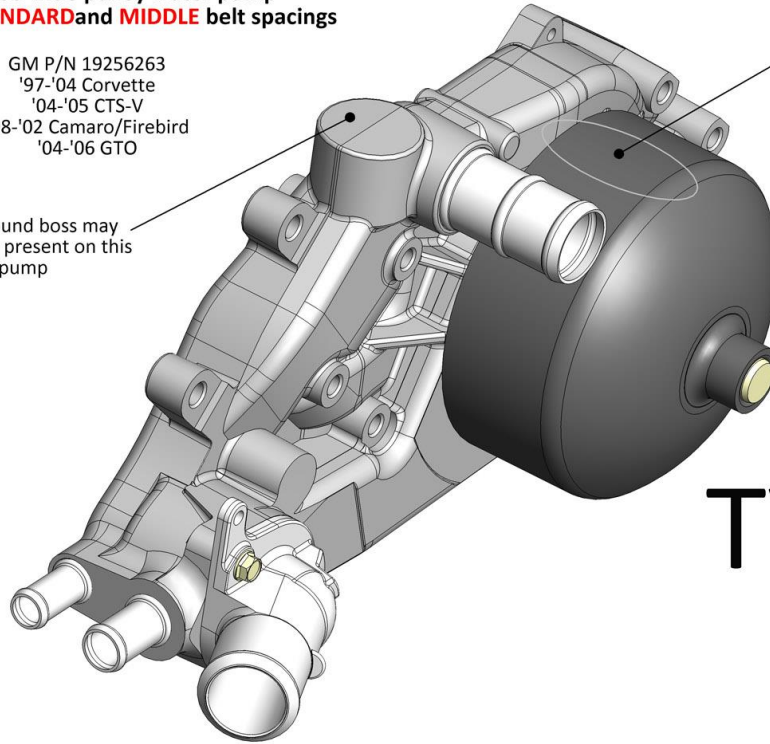

TYPE
1

LS2 Specific water pump
Works with **STANDARD** belt spacing

GM P/N 89018052
'05-'07 Corvette
'06-'07 CTS-V

Identifying features:
Narrow pulley and passenger's side outlet

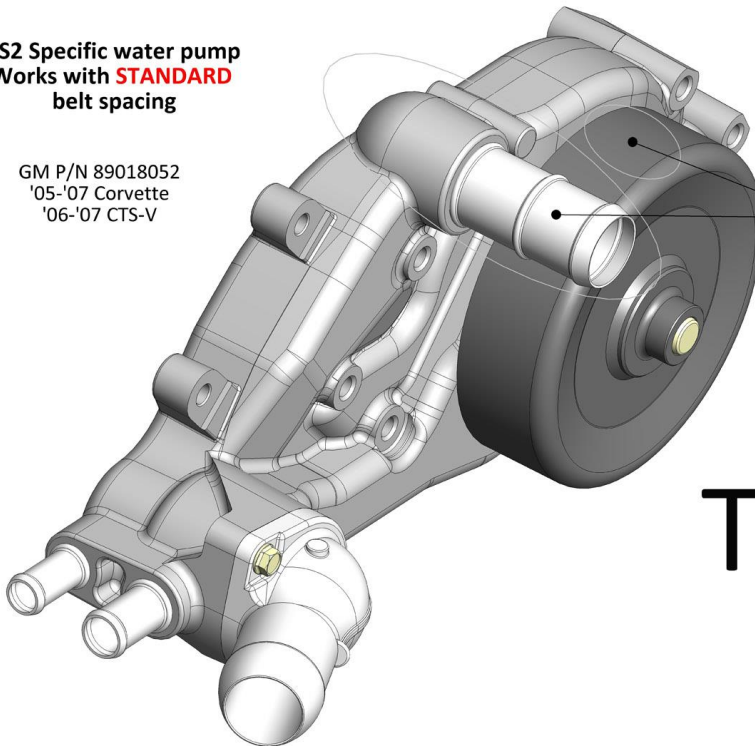

TYPE
2

LS3 Corvette/G8 water pump
Works with **STANDARD**
belt spacing

GM P/N 12604630
'08-UP Corvette
'08-'09 G8

Bracket Bolt Access

Either the water pump will need to be installed after the bracket or the area in red will need to be removed for bracket/spacer access. Remove the material so this boss shape is similar to that of the boss on water pumps TYPE 1, 2, or 5. Otherwise, the bolt will not pass by the boss.

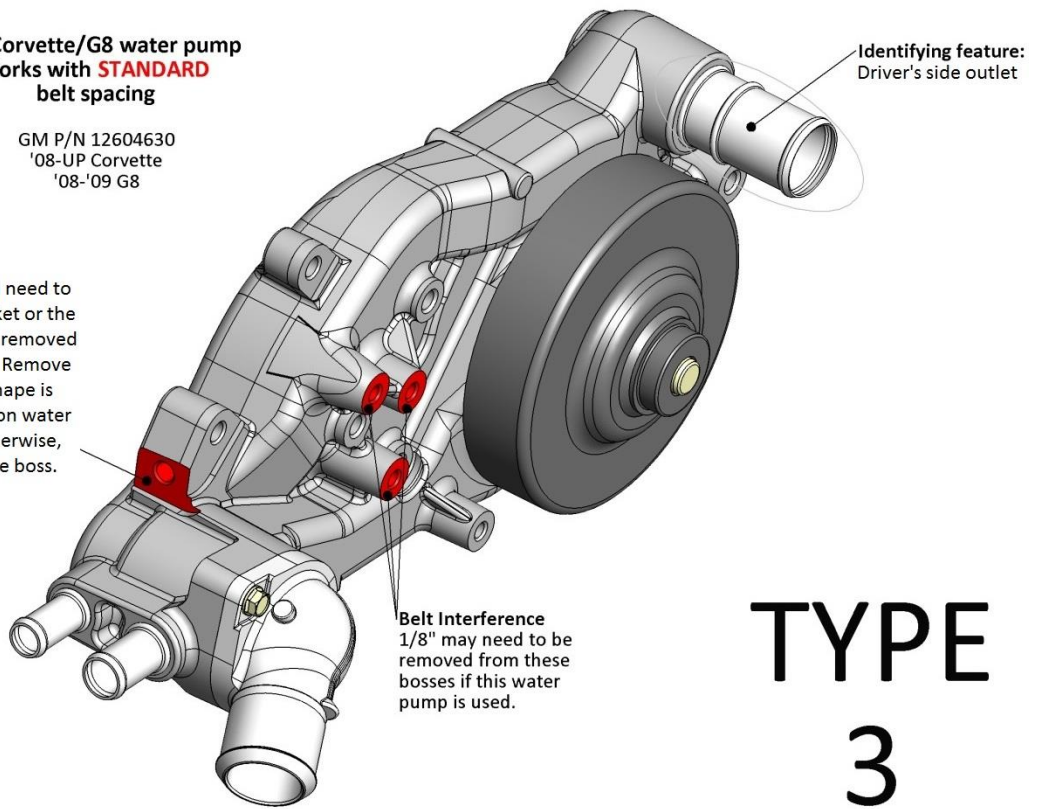

LS3/L99 Camaro water pump
Works with **LONG** belt spacing

GM P/N 19207665
'10-UP Camaro

Identifying feature:
Long tensioner Bosses

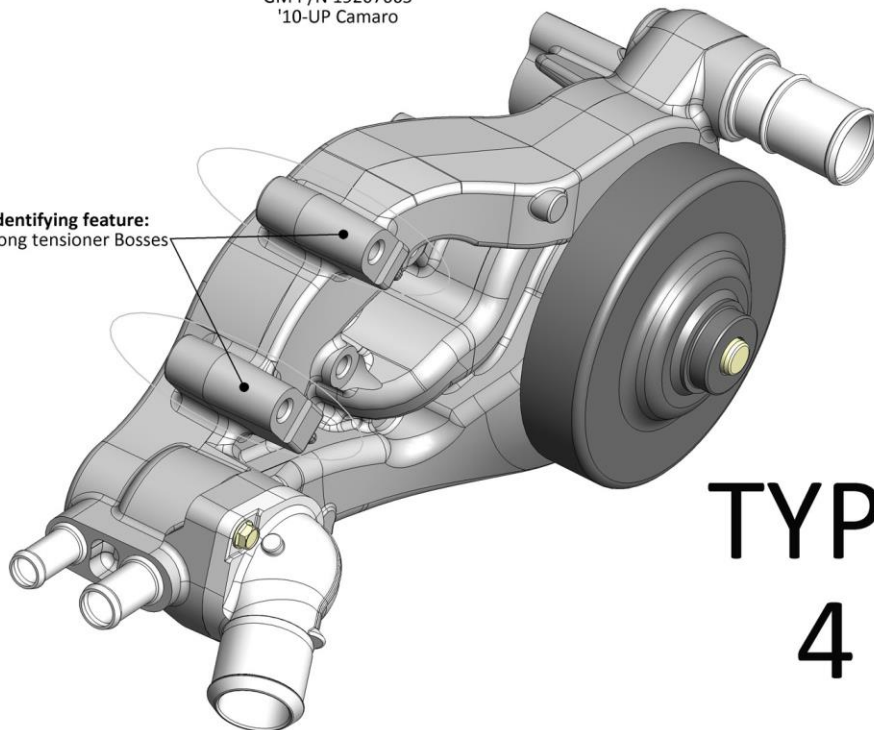

TRUCK water pump
Works with **LONG** belt spacing

GM P/N (Numerous)
All truck LS based engines

Identifying feature:
Upward pointing
inlet

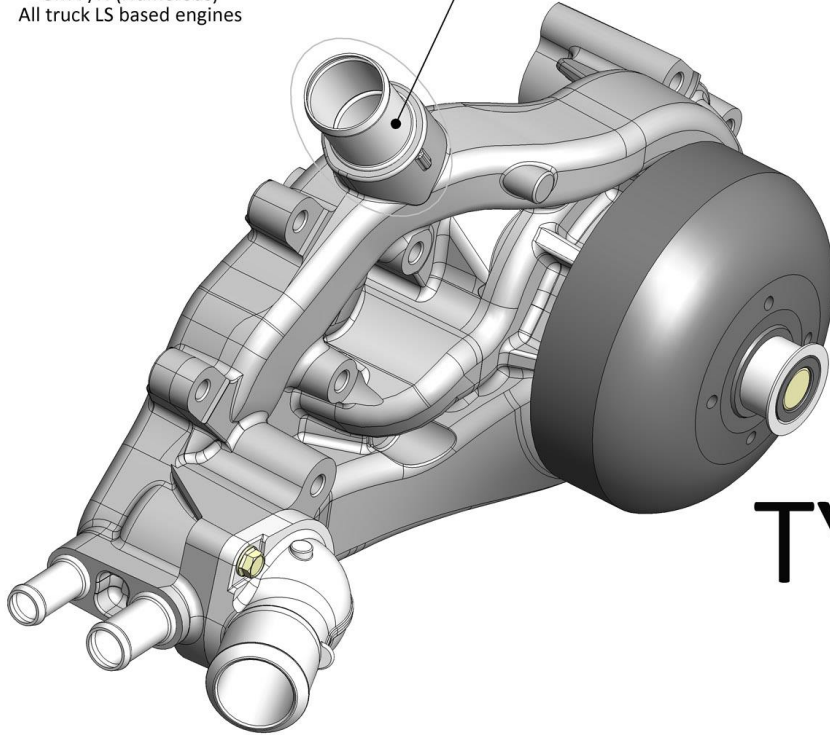

TYPE
5

Idler Pulley Options:

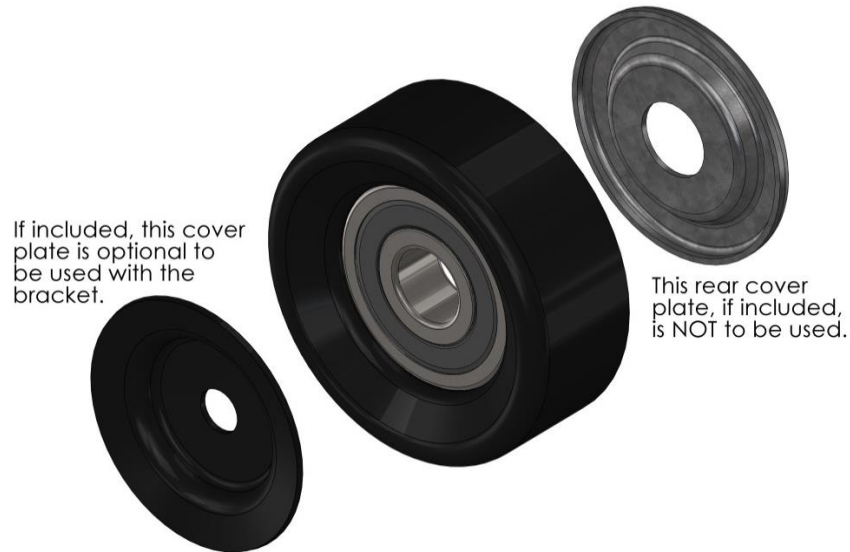

Idler pulley, 76 mm smooth
Holley part # 97-150
Application: '97 Corvette
DAYCO # 89059
GM # 12564401

When installing the passenger's side A/C bracket, a smooth pulley will need to be installed on the tensioner assembly. Retain the removed grooved pulley for bracket assembly.

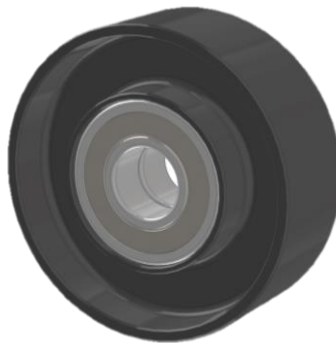

Late model idler pulleys such as GM # 12568996 found on '05-up Corvette have a double bearing and will NOT align with this bracket system.

Tensioner Assembly Options:

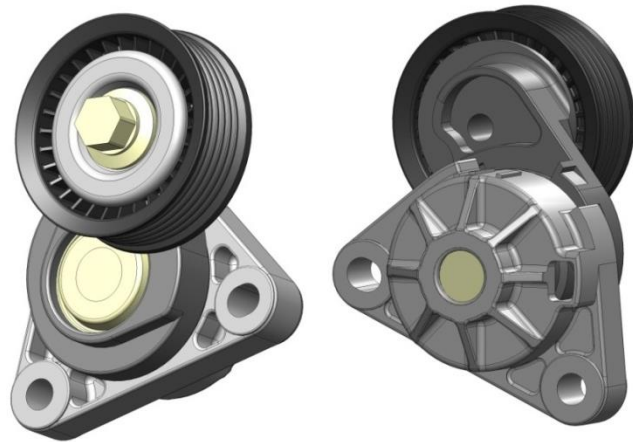

Tensioner assembly with 68 mm grooved pulley

Holley part # 97-151

Application: '97 Corvette

GATES # 38194

GM # 12559325

Because of a tensioner design change, Dayco # 89337 will no longer work with this bracket.

The above is the only style of tensioner that will work with the Holley bracket kits. The recommended version is common on 1997 - 2004 Corvettes. GM tensioner # 12569301 found on 2005 and up Corvettes may also be used if salvaged from the donor accessory drive, but confirm the tensioner pulley properly aligns with the belt after installation.

A/C Compressors Options and Warnings:

WARNING: LS engines are capable of high RPMs that can damage A/C compressor's complex moving internal parts. A tach or TPS monitoring RPM switch, such as NOS part # 15982NOS (for wiring information, see diagram on pg. 11), should be configured to deactivate the compressor clutch when the engine is above 4000 RPM.

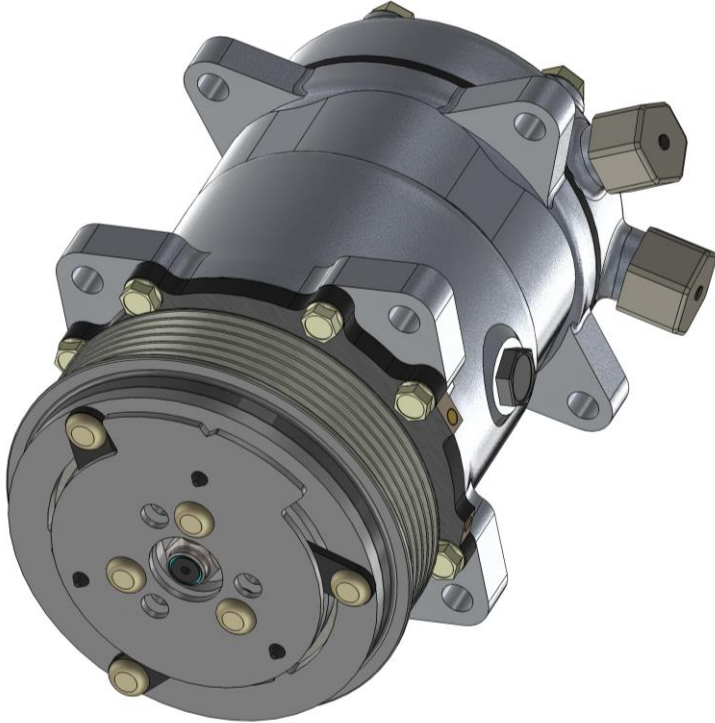

Sanden SD5 Compressor
(larger, higher capacity unit with 7000 maximum compressor RPMs)

Holley part # 199-101

Sanden #s SD508, SD5H14-S6669

Vintage Air #s 04808-VMA, 04808-VMQ, 048086, 047002-MUR, 047003-MUQ, 047006

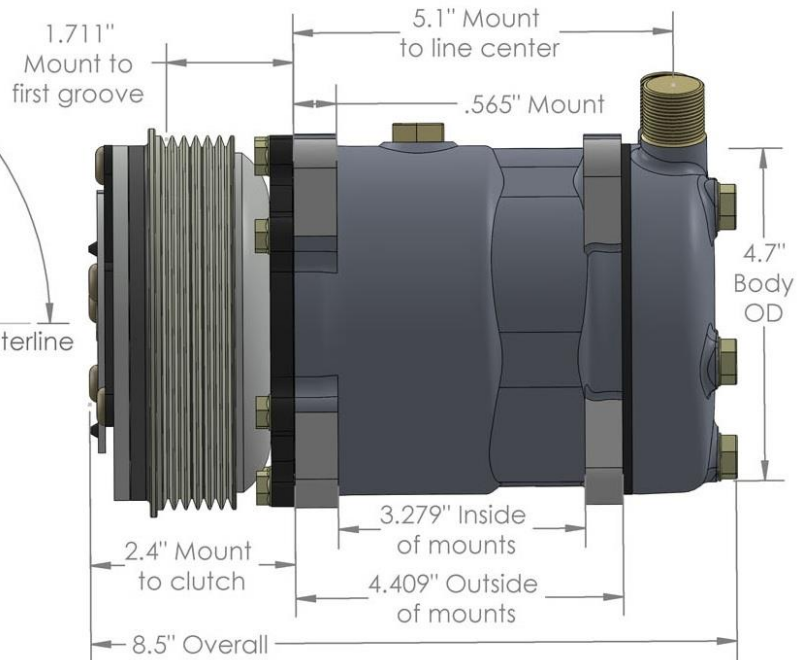
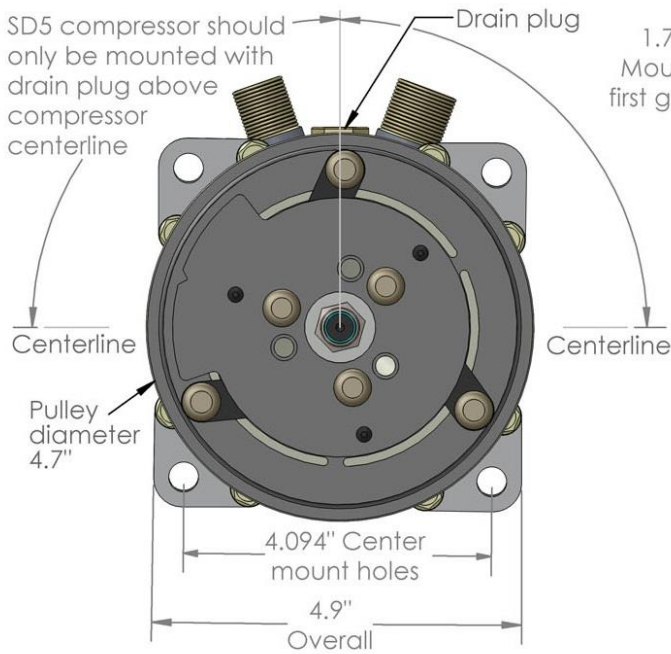

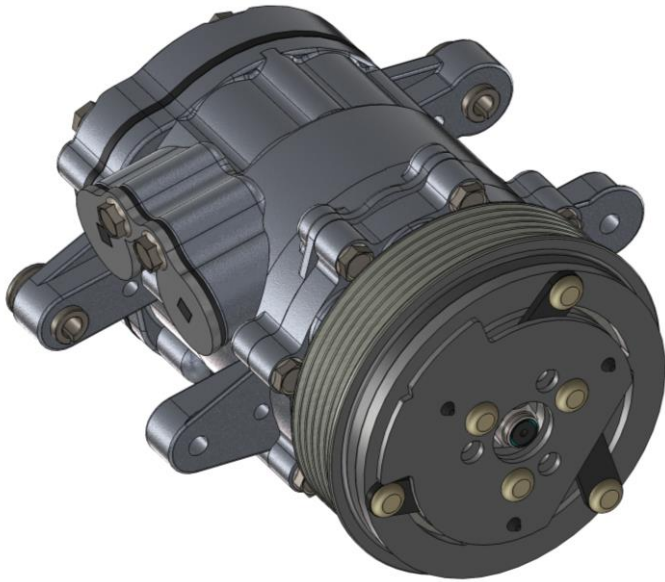

**Sanden SD7 Compressor
(smaller, lighter unit with 9300
maximum compressor RPMs)**

Holley part # 199-102

Sanden #s SD7, SD7B10-7176

**Vintage Air #s 04670-MTA, 04670-MTQ,
& 046705**

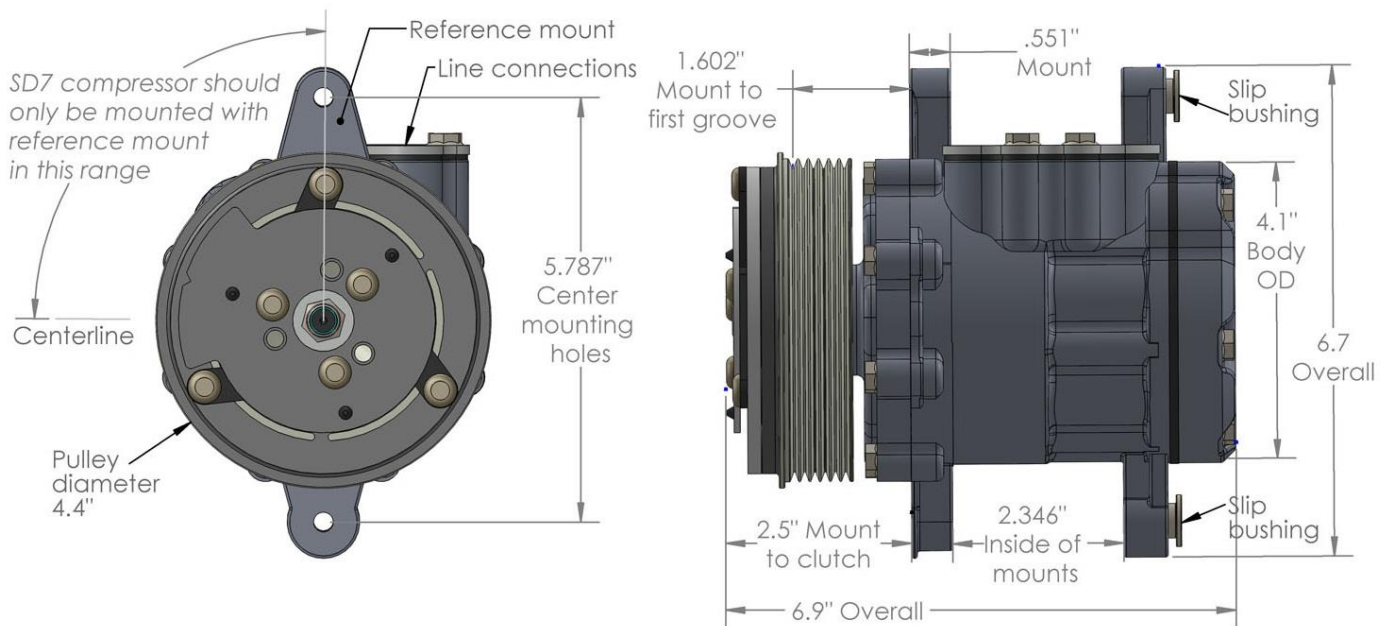

HELPFUL HINTS:

The passenger's side bracket will work with most 6, 7, and 8 groove SD5 and SD7 compressors commonly available in the aftermarket. This bracket does not work with the original Sanden compressor found on LS engines. If your compressor has more than six grooves, make certain the grooves chosen align to the grooved idler pulley on the Passenger's side bracket.

There is typically a one wire connection to the Sanden A/C clutch. This wire will activate the clutch when connected to 12 volts positive. Negative ground is through the case of the compressor. If painting or powder coating the brackets, **make certain** there is a good ground path to the engine block.

Wiring diagram

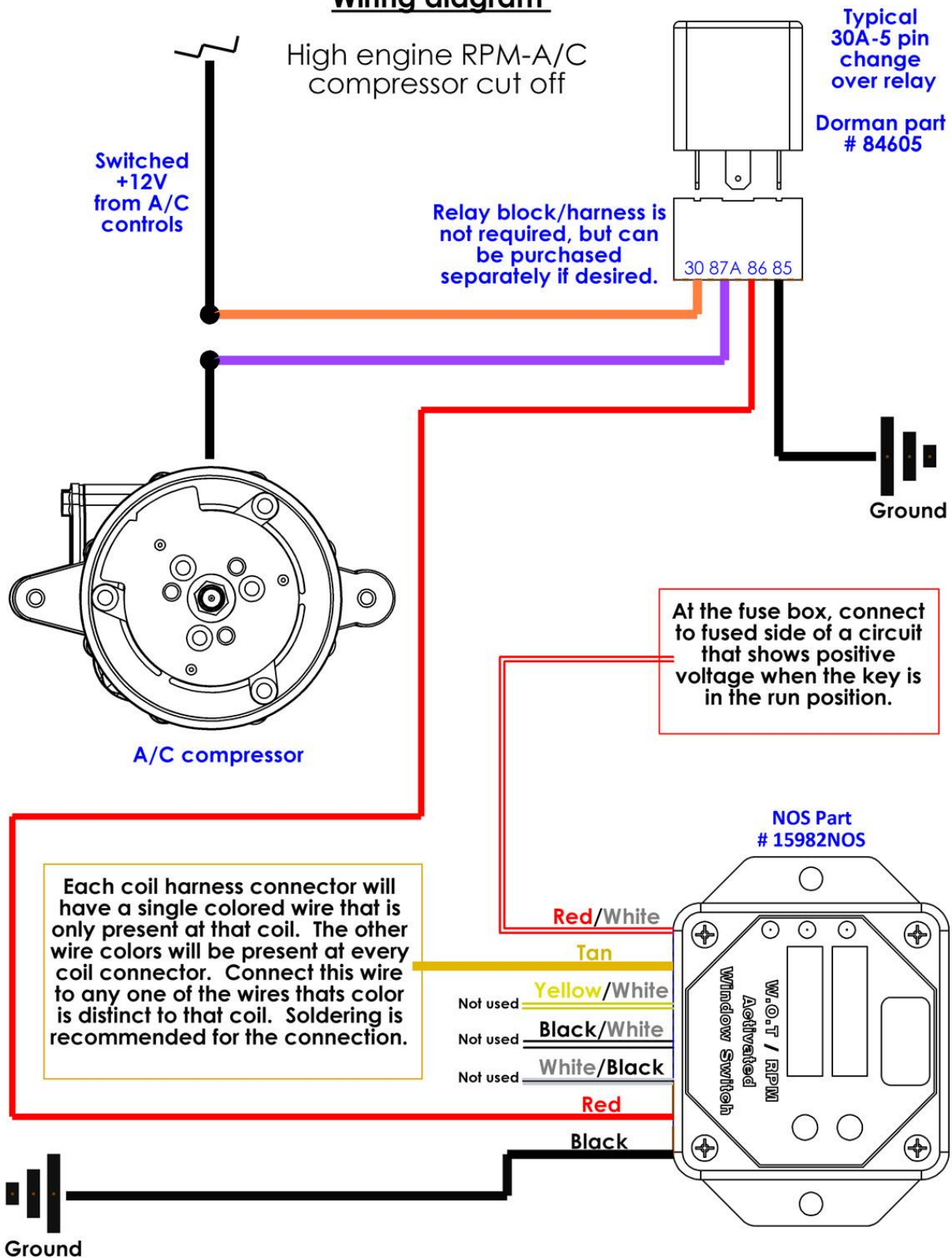

After reviewing the components needed for your specific application, parts can be sourced and the Holley kits can be installed. See the included assembly instructions for installation procedures.

Assembly Instructions



Holley Accessory Drive Kit Part Number 20-134

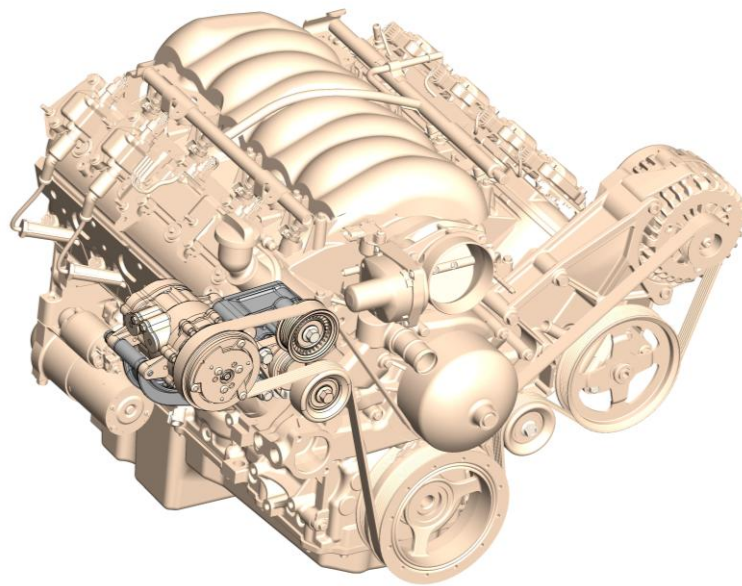





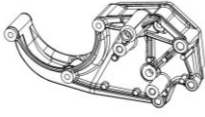
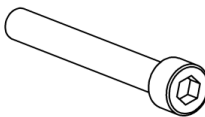
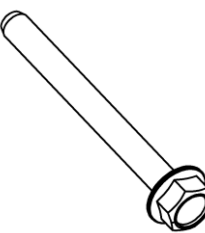

Parts List:

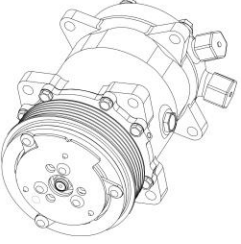
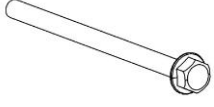
- Bracket requires application specific installation kit part # 21-1, 21-2, or 21-3

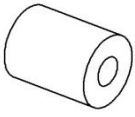
Parts included with 20-134 bracket kit (see list supplied with installation kit for additional parts):

PICTURE	QTY	DESCRIPTION	APPLICATION
	1	Passenger's Side Bracket Assembly	A/C Compressor & Tensioner
	1	Socket Head Cap Bolt, M10 x 1.5 x 30	Spacer to Passenger's Side Head
	3	Flange Head Bolt, M8 x 1.25 x 35	Passenger's Side Bracket to Spacer
	2	Flange Head Bolt, M10 x 1.5 x 35	Tensioner Assembly to Passenger's Side Bracket
	1	Flange Head Bolt, M10 x 1.5 x 35	Idler Pulley to Passenger's Side Bracket

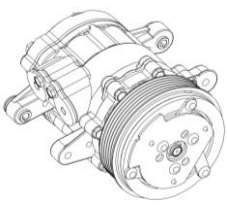
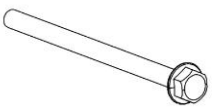
PICTURE	QTY	DESCRIPTION	APPLICATION
	USE THESE PARTS ONLY WHEN INSTALLING AN SD5 TYPE A/C COMPRESSOR (compressor not included)		
	3	Flange Head Bolt, M8 x 1.25 x 125	A/C Compressor Bolts
	3	M10 to M8 Sleeve	A/C Compressor Front Mounting Ears
	3	M8 Steel Spacer	Bracket to Rear A/C Compressor Ears
	3	M8 Flange Bushing	Rear A/C Compressor Ears
	3	Locking Nut, M8 x 1.25	Rear A/C Compressor Bolts

PICTURE	QTY	DESCRIPTION	APPLICATION
	USE THESE PARTS ONLY WHEN INSTALLING AN SD7 TYPE A/C COMPRESSOR (compressor not included)		
	2	Flange Head Bolt, M8 x 1.25 x 95	A/C Compressor Bolts
	2	M8 Thin Spacer	Bracket to Front A/C Compressor Ears

Passenger's Side Bracket Installation:

If the EVAP solenoid is located on the front of the passenger's side head, it will need to be relocated when using this A/C compressor bracket.

Parts pictured may vary slightly depending on the installation kit's intended application.

This spacer is not supplied with the bracket, but is required for installation on all applications. This spacer is supplied in the installation kit 21-1, 21-2, and 21-3.

Align spacer cosmetically to the bracket before tightening the bolts.

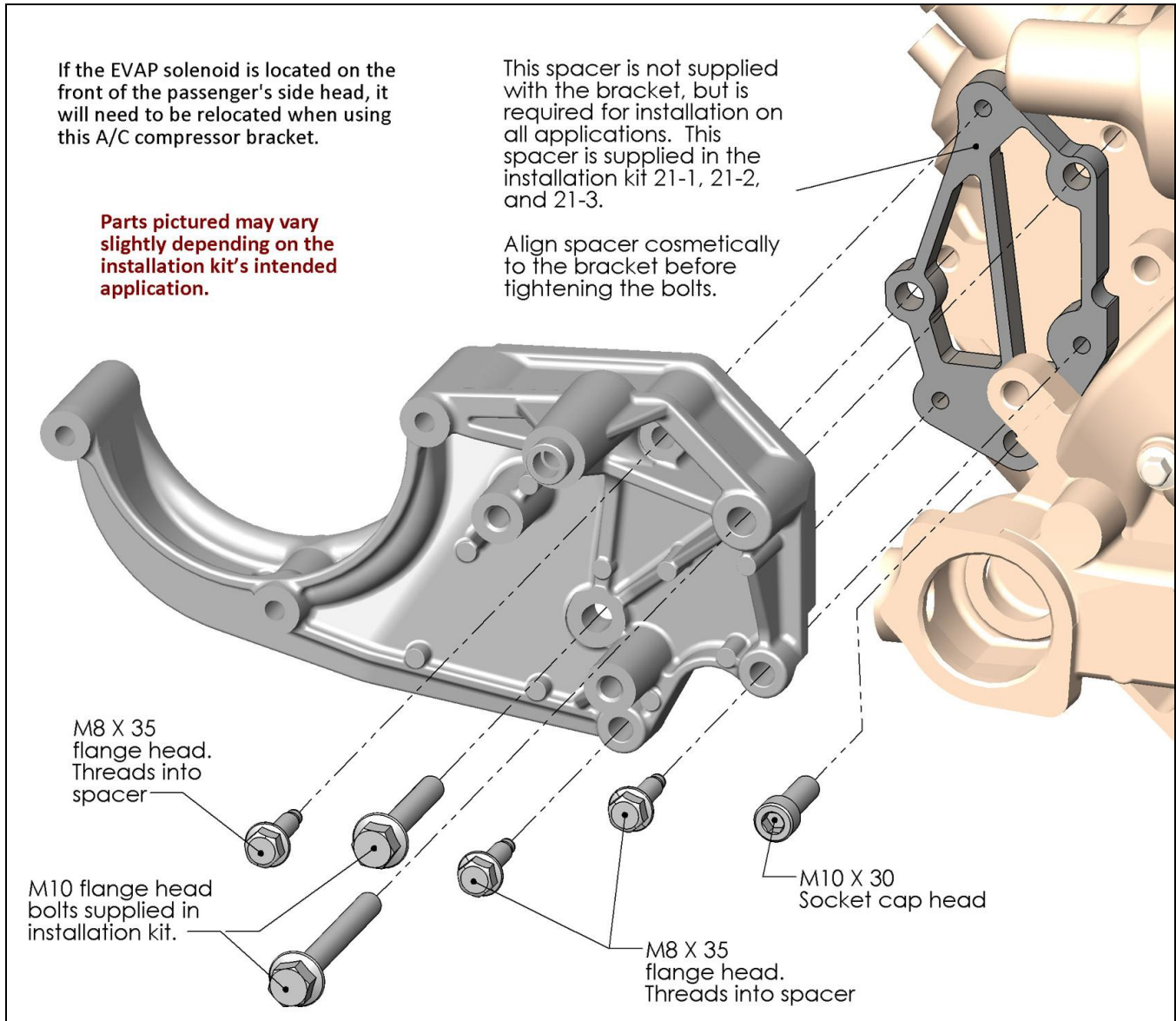

M8 X 35
flange head.
Threads into
spacer

M10 flange head
bolts supplied in
installation kit.

M10 X 30
Socket cap head

M8 X 35
flange head.
Threads into spacer

NOTE: Torque M8 bolts to 18 ft./lbs. and M10 bolts to 36 ft./lbs.

Idler & Tensioner Installation:

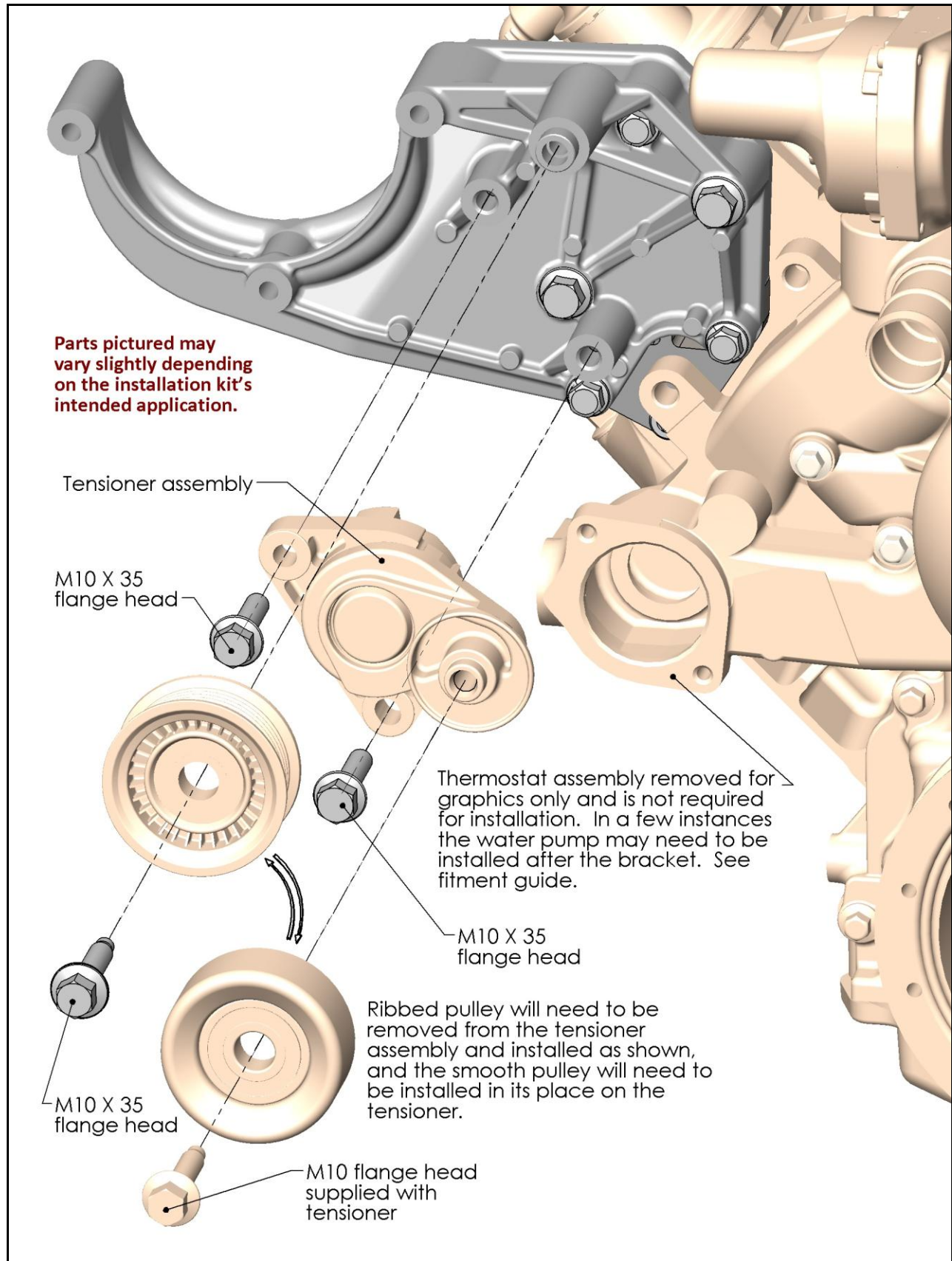

NOTE: Torque M8 bolts to 18 ft./lbs. and M10 bolts to 36 ft./lbs.

A/C Compressor Installation:

Installation step when installing an SD5 type A/C compressor

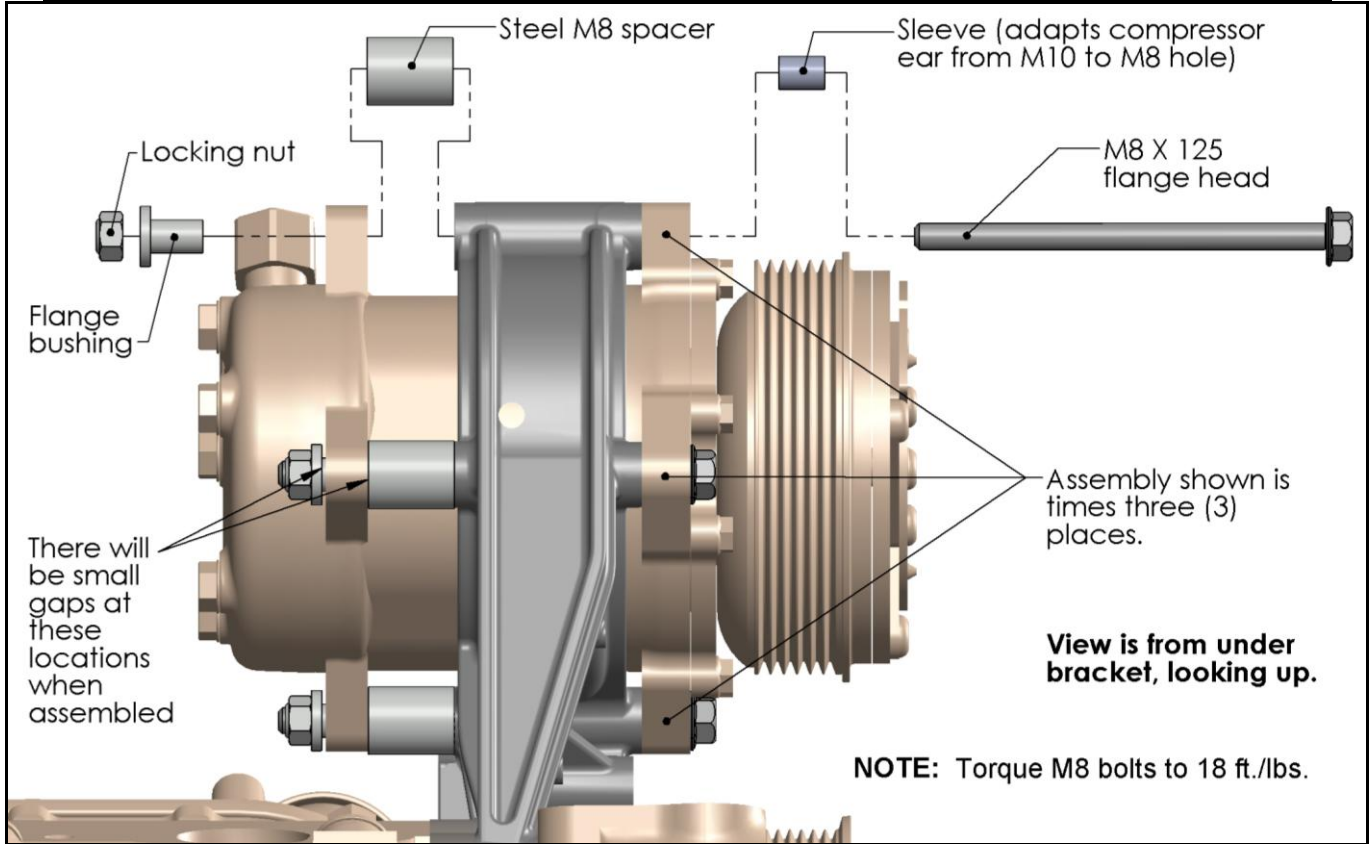

Installation step when installing an SD7 type A/C compressor

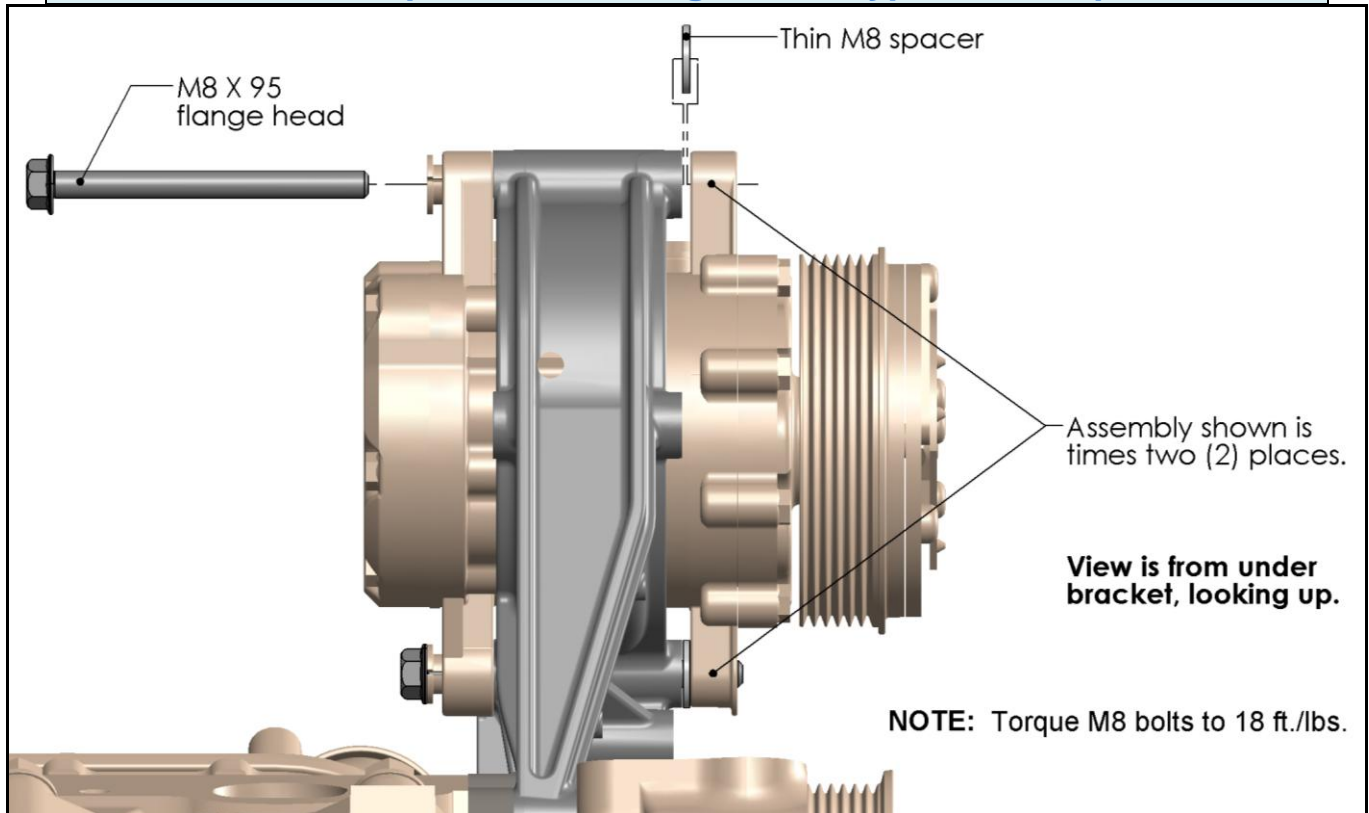

Belt Routing & Length Calculation:

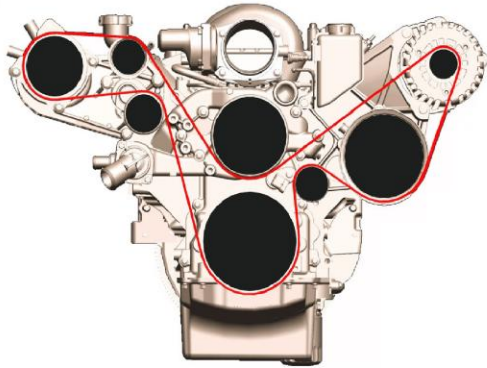

Corvette & Holley Driver's Side Brackets (20-135)

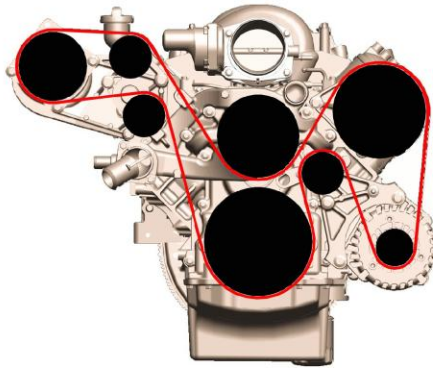

Camaro ('10-up), G8, CTS-V, GTO, & F-Body Brackets

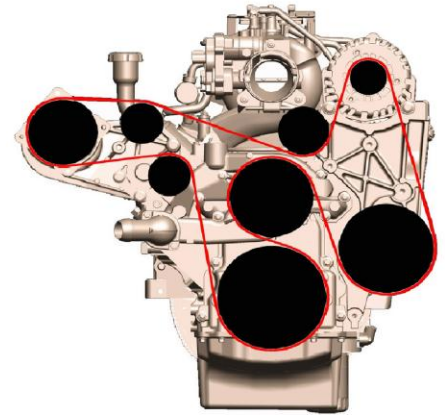

Truck Brackets

HELPFUL HINT: When installing the belt, route around all the pulleys except the water pump pulley. While fully rotating the tensioner arm, slip the belt on the smooth water pump pulley last.

Use serpentine belt part number 6PK2540 with SD5 compressor or 6PK2515 with SD7 compressor (not included in bracket kit) if using ALL Holley accessories and supplemental parts.

If you are installing a Holley bracket kit and are NOT using Holley accessories, you will have to measure to find the correct belt length as pulley diameters vary on accessories and will directly affect belt length.

To acquire this measurement, perform the following:

After all brackets and accessories are installed, route masking tape or string around the belt path. Leave the tensioner in the un-sprung position for this measurement. Mark or cut the tape/string to length and remove from the pulleys. Subtract 1 1/8" (28 mm) from the measured length to compensate for the un-sprung tensioner position. You will need to convert belt length to millimeters if measured in inches (inches X 25.4 = mm). Go to any auto parts store and ask for a 6PK0000 belt with the "0000" being the length in millimeters. For example, if you measured 2493 mm and then subtracted 28 mm, you would get 2465 mm, and the part number would be 6PK2465.

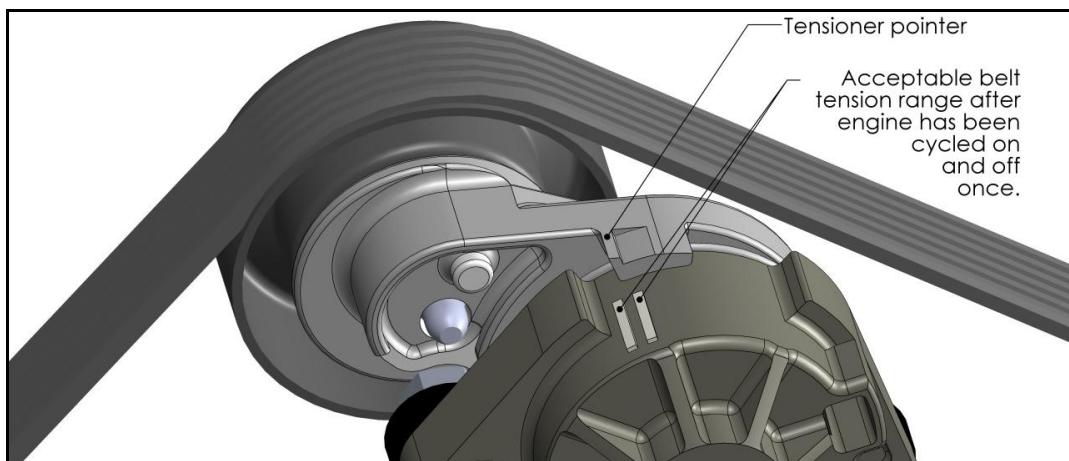

Learn more about replacement A/C and heating parts we have.