

Fitment and Required Components Guide



Holley Accessory Drive Kit Part Number 20-132

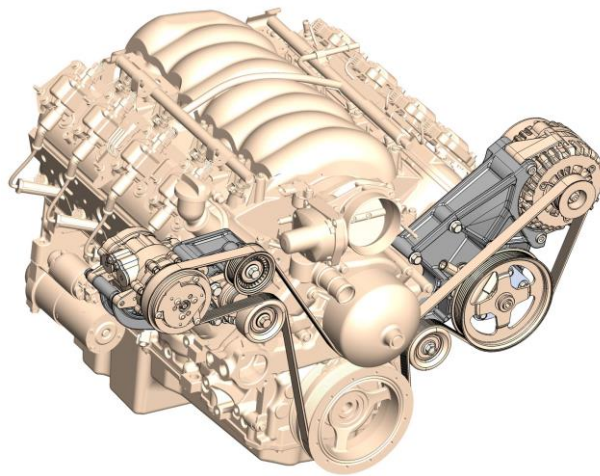
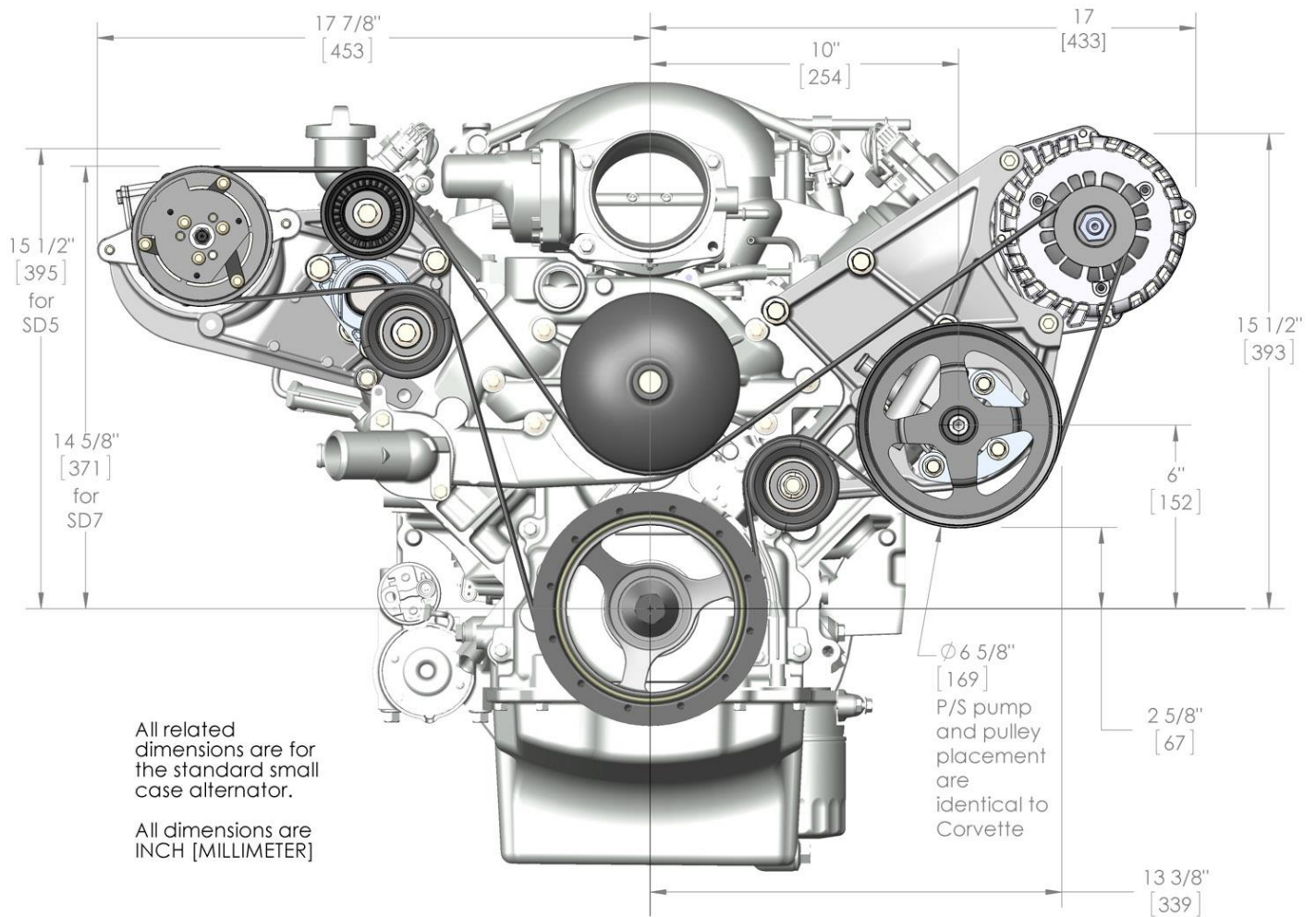

Table of Contents

Introduction:	2
Crank Pulley Belt Alignment Determination:	3
Overview of Parts Required (but NOT included with 20-132 bracket kit):	3
Water Pump Determination:	4
Idler Pulley Options:	7
Tensioner Assembly Options:	8
A/C Compressors Options and Warnings:	9
Power Steering Pump Options:	12
Power Steering Pump Pulleys:	13
Standard Diameter Pulley:	13
Small Diameter Pulley:	13
Alternator Options:	15
Power Steering Pump Reservoir Options:	16



Introduction:

Holley's accessory drive kits offer clean, economical mounting of all LS engine accessories. These brackets look truly at home on any LS engine as if they came from the factory this way.

Holley's kits supply the required brackets and hardware needed for installation, but allow you to choose the source for supplemental accessories and components that are often already on the donor engine or the vehicle the engine is going into. Whether sourcing from the salvage yard, the local auto parts store, your GM parts dealer, or Holley and their premium matched components; you pick the source that matches your expectations and budget.

This guide will help with locating and sourcing components, as well as supplying notes and helpful hints for each. The first step is to determine which belt alignment you want to proceed with. This is determined by the crank pulley and often, but not always, the water pump. If clearance to the radiator is an issue, the compact STANDARD spacing common on the Corvette may be preferred. Otherwise, it is most cost effective to retain the existing crank pulley/water pump and space the bracket and other accessories to match. An application specific installation kit (part # 21-1, 21-2, or 21-3) is REQUIRED for ALL bracket kits.

Note: All Corvette part application references in this guide are to NON-supercharged LS engines.

Crank Pulley Belt Alignment Determination:

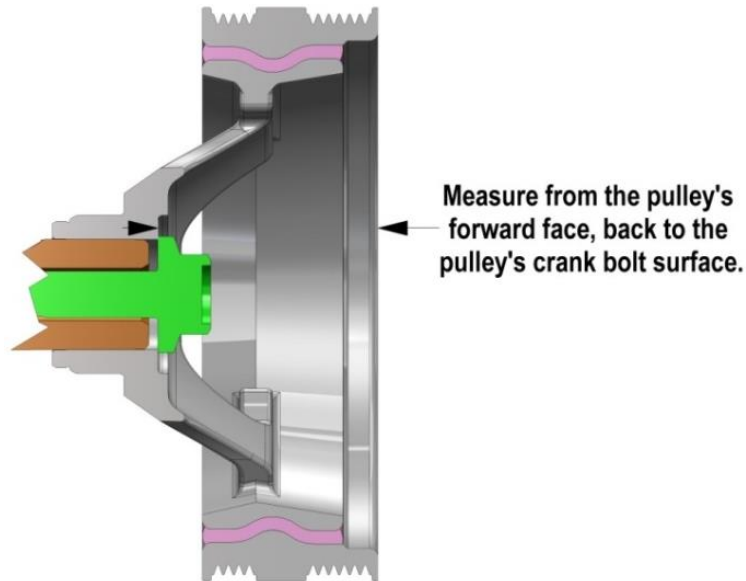

See the chart below for reference dimensions.

Overview of Parts Required (but NOT included with 20-132 bracket kit):

Components with specific belt alignments

Belt Alignment Group	LS Application (Alignment Specific)	Holley Installation Kit (Alignment Specific)	Crank Pulley (Reference Dimension)		Water Pump (Alignment Specific)
					GM #
Standard	Corvette / CTS-V / G8	21-1	1.5"	37 MM	19256263, 89018052, or 12604630
Middle	F-body / GTO	21-2	2.25"	55 MM	19256263
Long	Camaro ('10-UP) / Truck (all)	21-3	3"	75 MM	19207665 or any truck WP

Components that will work with all belt alignments

Tensioner Assembly	Smooth Idler Pulley	Alternator	Power Steering Pump Pulley	Power Steering Pump	Reservoir Assembly (optional)	A/C Compressor (Sanden Types)
Holley # / GM #	Holley # / GM #	Holley # / GM #	Holley # / GM #	Holley # / GM #	Holley # / GM #	Holley # / Sanden #
97-151 / 12559325	97-150 / 12564401	197-300 or 197-301 / 10480326 or 15754097	97-152 / 12568997 or 12578552	198-100 / 26120639 or 25960709	198-200 (kit) / 15907878, 26095119, 26046502, and 12555222	199-101 / SD508, SD5H14-S6669 & similar OR 199-102 / SD7, SD7B10-7176 & similar

Water Pump Determination:

To determine which water pump type you have, refer to the following illustrations:

LS1/LS2/LS6 wide pulley water pump
Works with **STANDARD** and **MIDDLE** belt spacings

GM P/N 19256263
'97-'04 Corvette
'04-'05 CTS-V
'98-'02 Camaro/Firebird
'04-'06 GTO

This round boss may not be present on this water pump

Identifying feature:
Wide pulley allowing for both standard and middle belt spacings

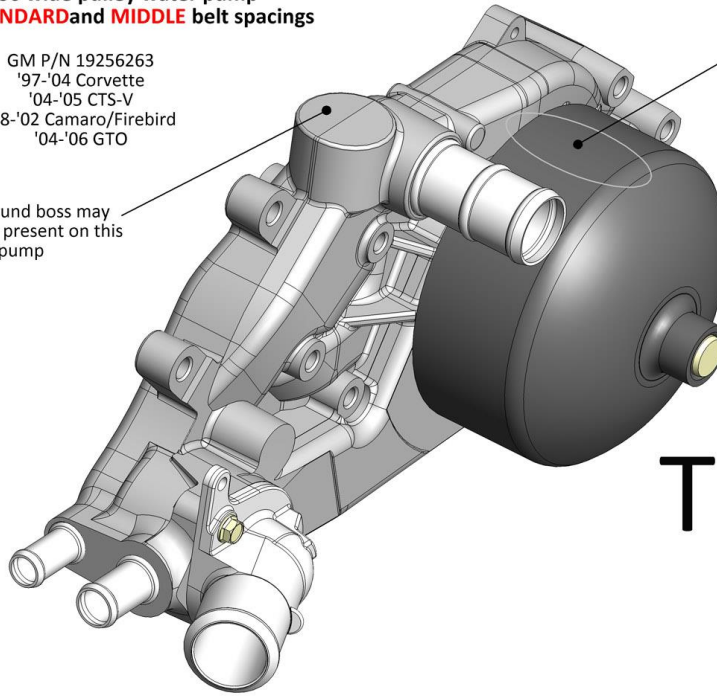

TYPE
1

LS2 Specific water pump
Works with **STANDARD** belt spacing

GM P/N 89018052
'05-'07 Corvette
'06-'07 CTS-V

Identifying features:
Narrow pulley and passenger's side outlet

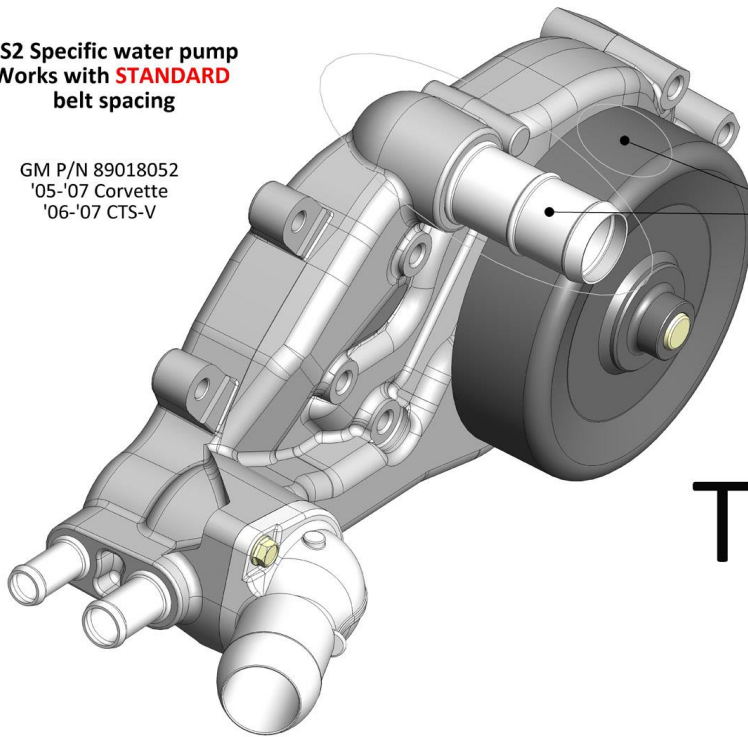

TYPE
2

LS3 Corvette/G8 water pump
Works with **STANDARD**
belt spacing

GM P/N 12604630
'08-UP Corvette
'08-'09 G8

Bracket Bolt Access

Either the water pump will need to be installed after the bracket or the area in red will need to be removed for bracket/spacer access. Remove the material so this boss shape is similar to that of the boss on water pumps TYPE 1, 2, or 5. Otherwise, the bolt will not pass by the boss.

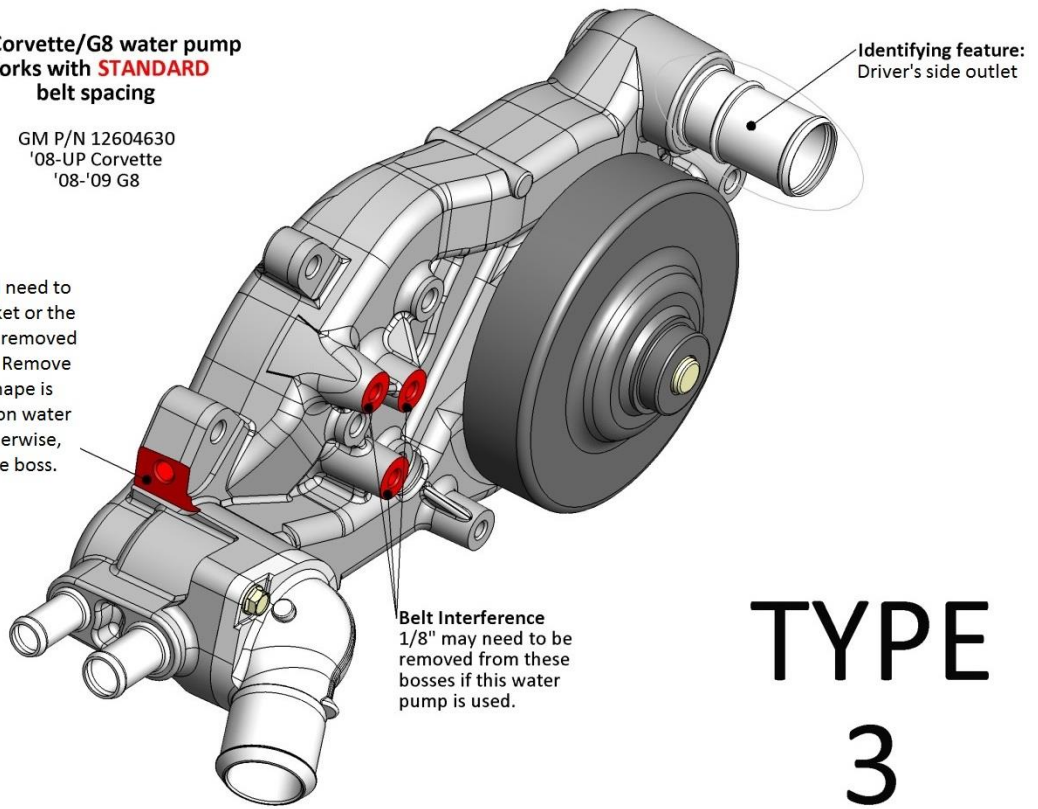

LS3/L99 Camaro water pump
Works with **LONG** belt spacing

GM P/N 19207665
'10-UP Camaro

Identifying feature:
Long tensioner Bosses

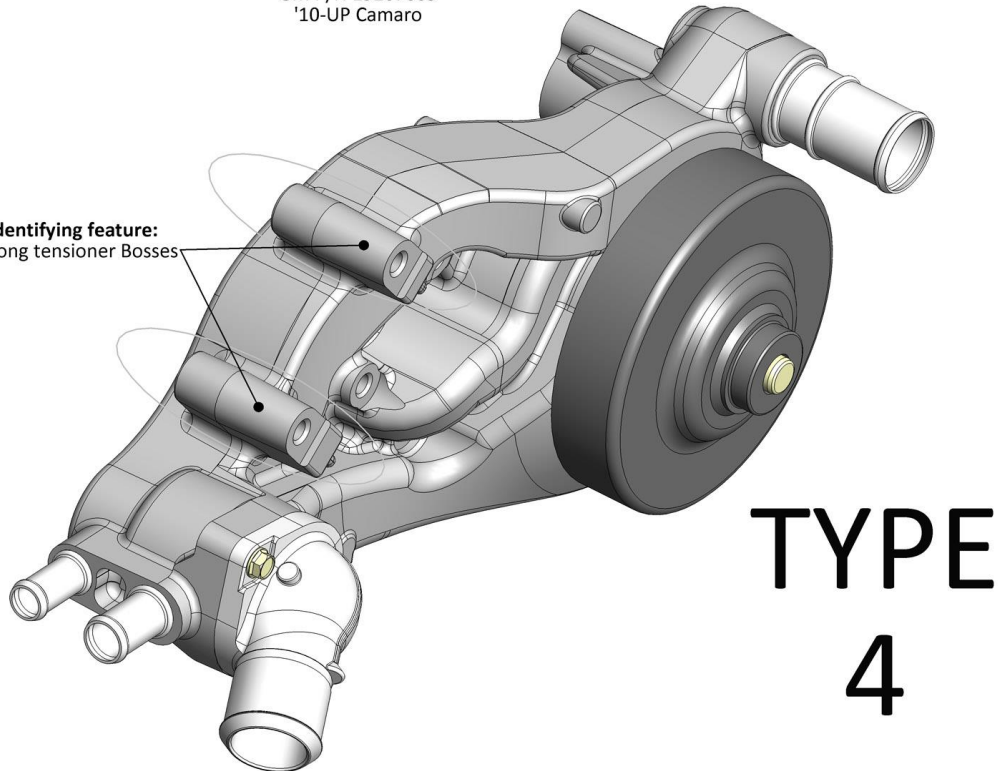

TRUCK water pump
Works with **LONG** belt spacing

GM P/N (Numerous)
All truck LS based engines

Identifying feature:
Upward pointing
inlet

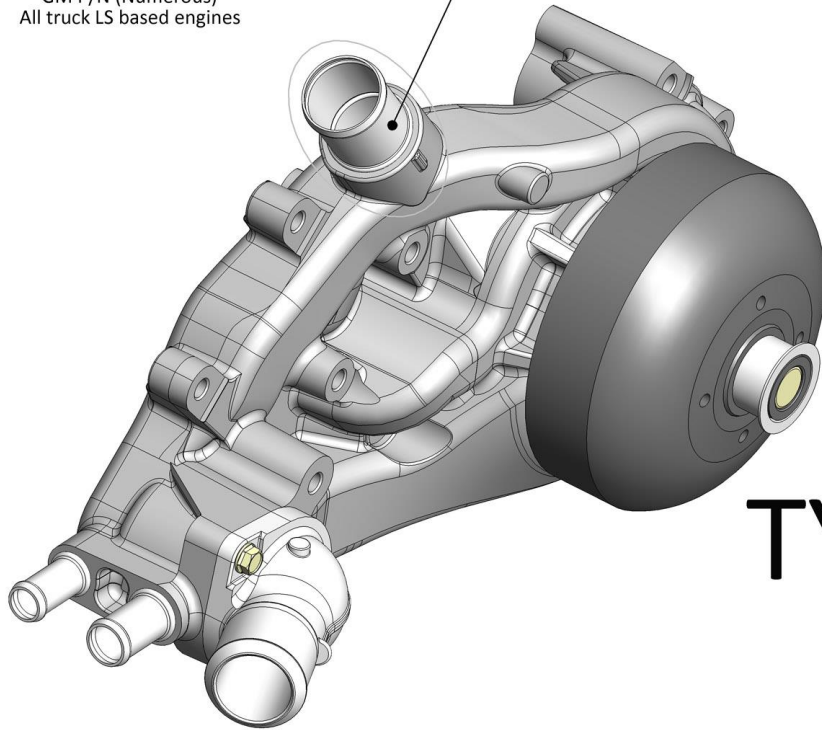

TYPE
5

Idler Pulley Options:

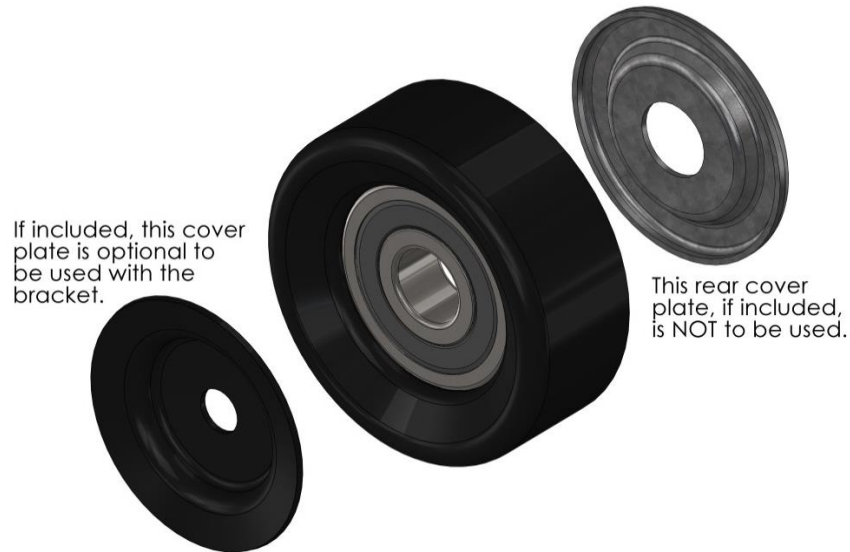

Idler pulley, 76 mm smooth
Holley part # 97-150
Application: '97 Corvette
DAYCO # 89059
GM # 12564401

Two smooth idler pulleys will be required. When installing the passenger's side A/C bracket, a smooth pulley will need to be installed on the tensioner assembly. Retain the removed grooved pulley for bracket assembly.

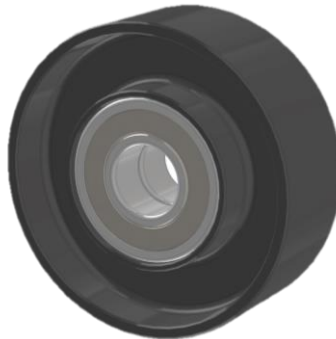

Late model idler pulleys such as GM # 12568996 found on '05-up Corvette have a double bearing and will NOT align with this bracket system.

Tensioner Assembly Options:

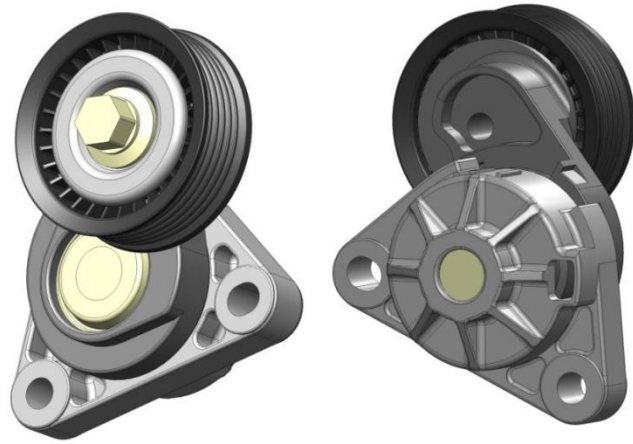

Tensioner assembly with 68 mm grooved pulley

Holley part # 97-151

Application: '97 Corvette

GATES # 38194

GM # 12559325

Because of a tensioner design change, Dayco # 89337 will no longer work with this bracket.

The above is the only style of tensioner that will work with the Holley bracket kits. The recommended version is common on 1997 - 2004 Corvettes. GM tensioner # 12569301 found on 2005 and up Corvettes may also be used if salvaged from the donor accessory drive, but confirm the tensioner pulley properly aligns with the belt after installation.

A/C Compressors Options and Warnings:

WARNING: LS engines are capable of high RPMs that can damage A/C compressor's complex moving internal parts. A tach or TPS monitoring RPM switch, such as NOS part # 15982NOS (for wiring information, see diagram on pg. 11), should be configured to deactivate the compressor clutch when the engine is above 4000 RPM.

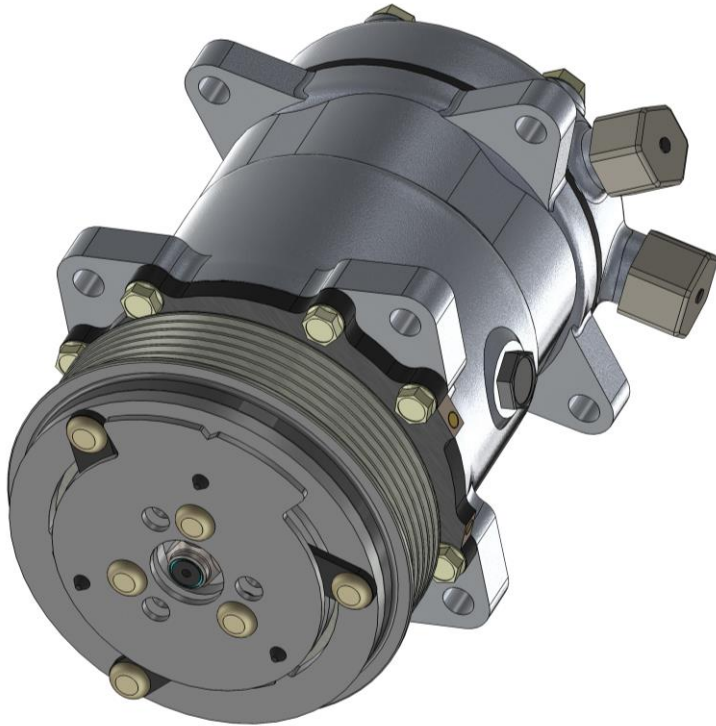

Sanden SD5 Compressor
(larger, higher capacity unit with 7000 maximum compressor RPMs)

Holley part # 199-101

Sanden #s SD508, SD5H14-S6669

Vintage Air #s 04808-VMA, 04808-VMQ, 048086, 047002-MUR, 047003-MUQ, 047006

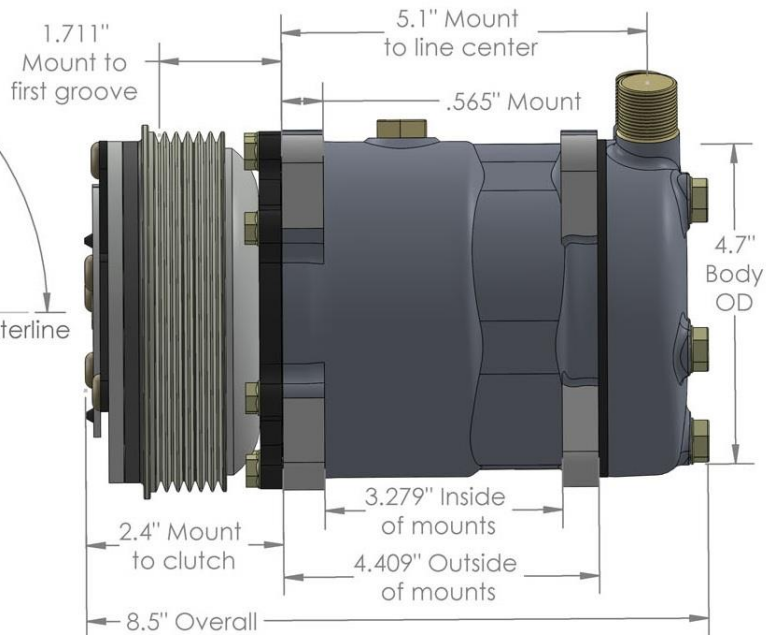
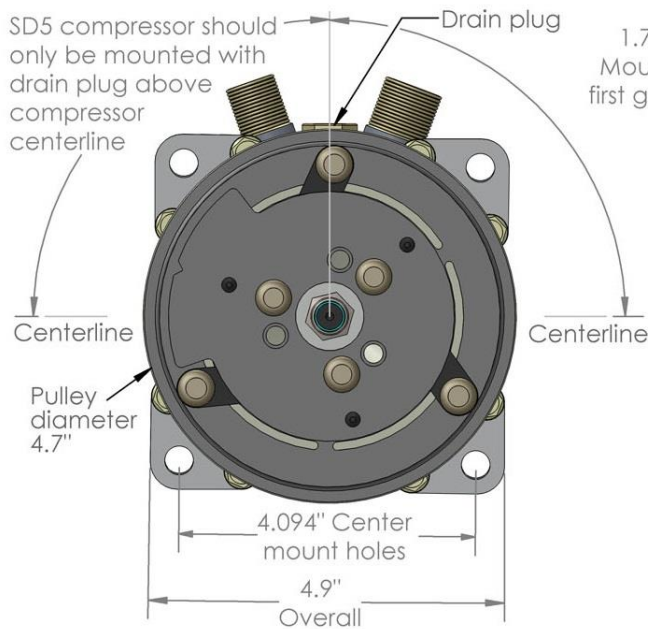

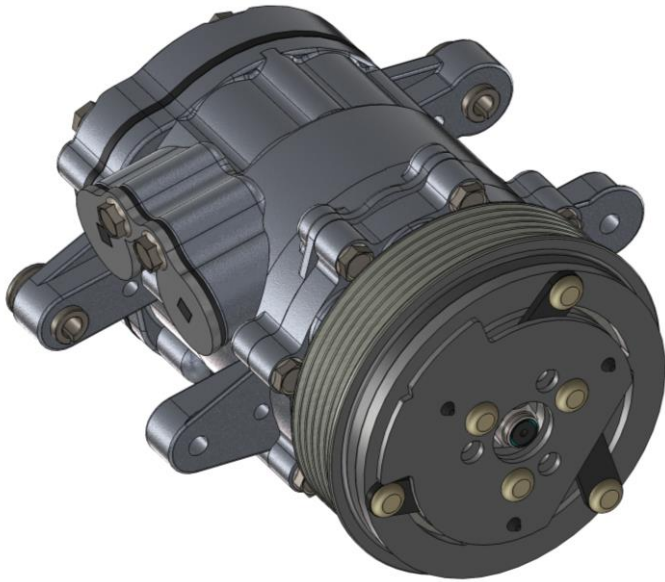

**Sanden SD7 Compressor
(smaller, lighter unit with 9300
maximum compressor RPMs)**

Holley part # 199-102

Sanden #s SD7, SD7B10-7176

**Vintage Air #s 04670-MTA, 04670-MTQ,
& 046705**

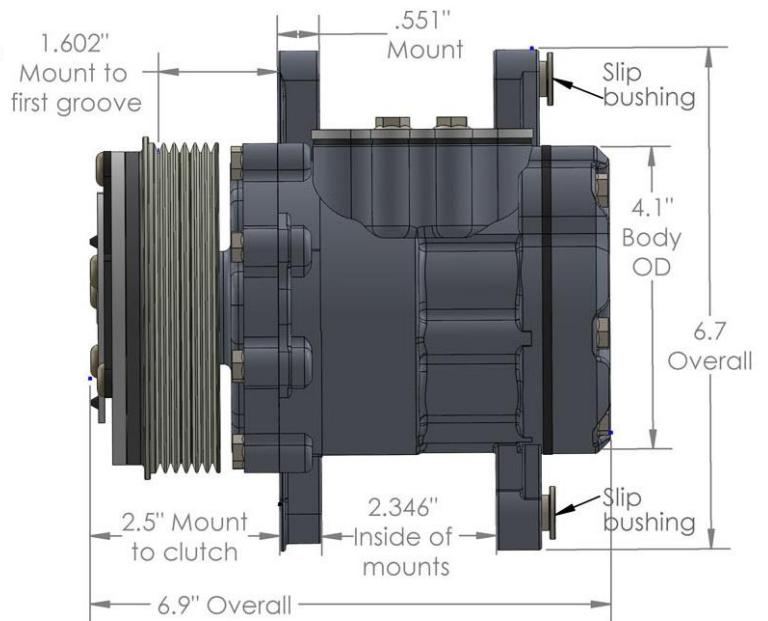
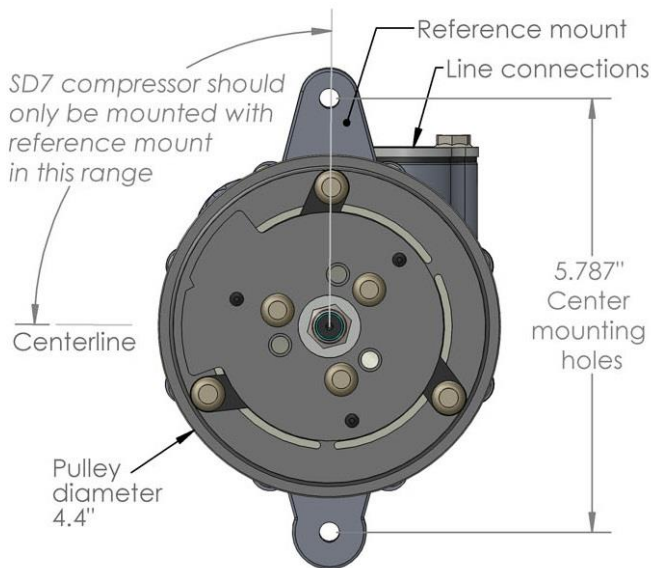

HELPFUL HINTS:

The passenger's side bracket will work with most 6, 7, and 8 groove SD5 and SD7 compressors commonly available in the aftermarket. This bracket does not work with the original Sanden compressor found on LS engines. If your compressor has more than six grooves, make certain the grooves chosen align to the grooved idler pulley on the Passenger's side bracket.

There is typically a one wire connection to the Sanden A/C clutch. This wire will activate the clutch when connected to 12 volts positive. Negative ground is through the case of the compressor. If painting or powder coating the brackets, **make certain** there is a good ground path to the engine block.

Wiring diagram

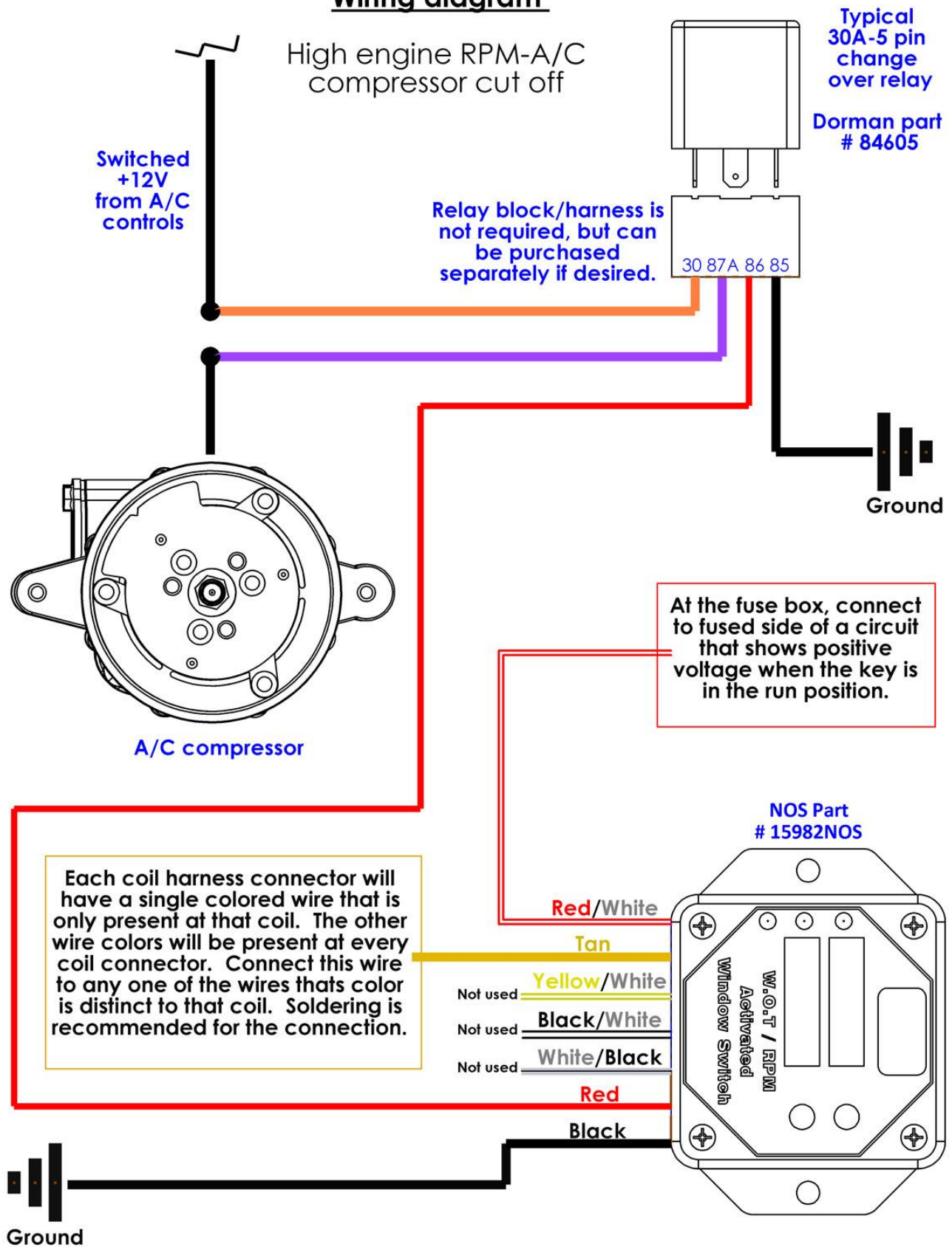

Power Steering Pump Options:

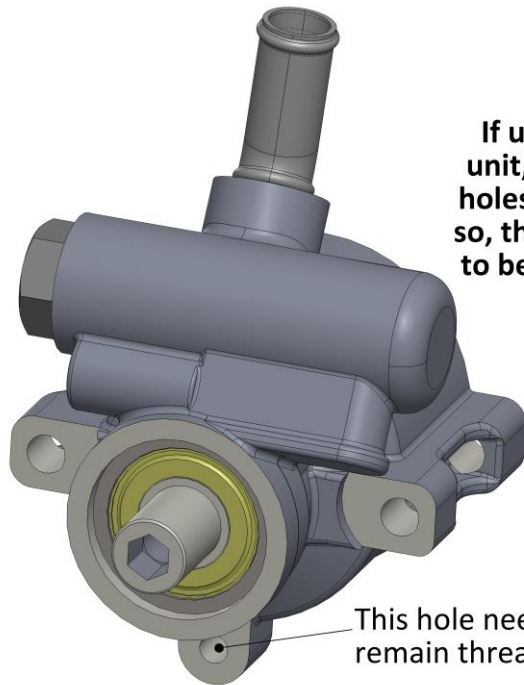

This hole needs to remain threaded.

If using a non-Corvette unit, the pump's through holes may be threaded. If so, these threads will need to be drilled out to 5/16".

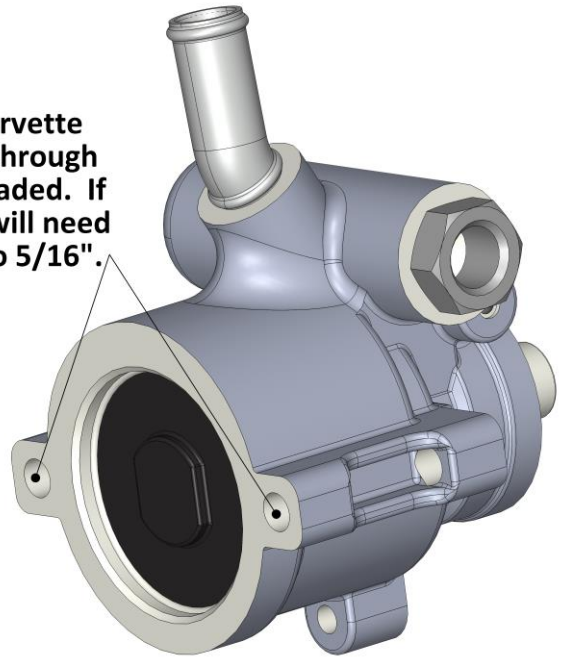

Aluminum power steering pump
Holley part # 198-100
Application: '09 Corvette, all except supercharged
GM # 26120639

Steel power steering pump
Application: '97 Corvette
GM # 25960709

The Holley driver's side bracket uses the standard (1997 and up) Corvette power steering pump (Saginaw TC type). Other pumps of the same housing and type may work, but the bracket is optimized for the Corvette pump.

HELPFUL HINTS: Non-Corvette pumps will not have the correctly positioned reservoir hose tube. Also note that remanufactured pumps may have the formed tube clogged improperly. Early Corvette pumps are steel where later years were aluminum.

Power Steering Pump Pulleys:



NOTE: If using AN fittings on the pressure line, Holley P/N 961961ERL AN extension/adaptor is required.

There are several pulleys that will fit the pump, but some do not have the correct belt alignment for this application. See applicable service manual for pulley installation procedures.

Standard Diameter Pulley:



Power steering pump pulley
Holley P/N 97-152
Application: '97 Corvette
GM# 12568997
OD to grooves: 6.35"
OD overall: 6.70"

Small Diameter Pulley:

Power steering pulleys may interfere with the suspension A-arm in certain swap applications. Choosing a smaller pulley in these situations can give additional clearance.



Power steering pump pulley
Holley P/N 97-154
OD to grooves: 5.45"
OD overall: 5.75"

WARNING! Smaller power steering pulleys, such as a 97-154 can rotate the pump beyond recommended RPMs. To correct this, a 25% under-drive balancer should be used if choosing a pump pulley smaller than 6" OD.

Belt Alignment Group	LS Application (Alignment Specific)	Balancer (25% under-drive)
		Powerbond P/N
Standard	Corvette/CTS-V/G8	PBU1117SS25
Middle	F-body/GTO	PBU1480SS25
Long	Camaro ('10-UP)/ Truck (all)	PBU1190SS25

*Belt length will change when moving from standard pulleys to different diameters.

Helpful Hint: The above pulleys have openings for pump mounting bolts and can be installed before the pump is installed.

Alternator Options:

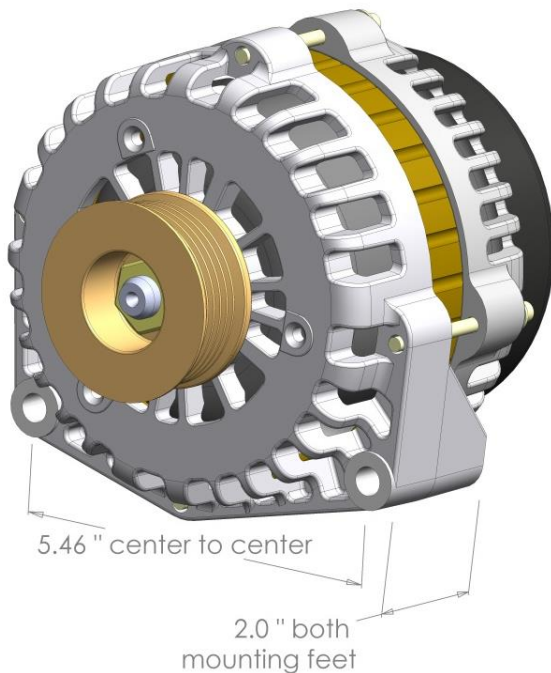

Case size: SMALL (130 mm)
Standard amperage: 105 AMPs
Holley part # 197-300
Application: '04 Chevy Silverado 5.3L (standard 105 amp choice)
GM/Delco # 10480326
Series/Lester # AD230/8247
Holley harness pigtail # 197-400

Case size: LARGE (144 mm)
High amperage: 130-145 AMPs
Holley part # 197-301
Application: '04 Chevy Silverado 5.3L (optional 130/145 amp choice)
GM/Delco # 15754097
Series/Lester # AD244/8292
Holley harness pigtail # 197-400

The Holley driver's side bracket uses standard alternators with 5.46" bolt spacing. This alternator type is common on most '96-'05 GM trucks and '98-'06 Camaro/Firebird/GTOs. There are two alternator amperages available in this type. Note: The Holley bracket DOES NOT work with '97-UP Corvette or '10-UP Camaro alternators which have 6" (154 mm) center bolt spacing.

When wiring the alternator, connect the "L" terminal labeled on the alternator to switched voltage that is "on" when the key is in the run position. There must be either a charge indicator light (standard dash bulb) or a 560 ohm, 1/2 watt resistor (Radio Shack #271-1116) in-line on this wire. Holley's part # 197-400 already has the resistor in line.

Late model alternators with only two pins visible in the alternator's harness plug instead of four, will NOT work for this application. They require the vehicles ECU to function. An alternator repair shop may be able to change out the internal regulator to the 4-pin type if needed.

Power Steering Pump Reservoir Options:

The Holley driver's side bracket works with reservoirs found on '97-up Corvettes. Other remote reservoirs can be custom fitted with this bracket as well. All the below reservoir parts are included in **Holley kit # 198-200**.

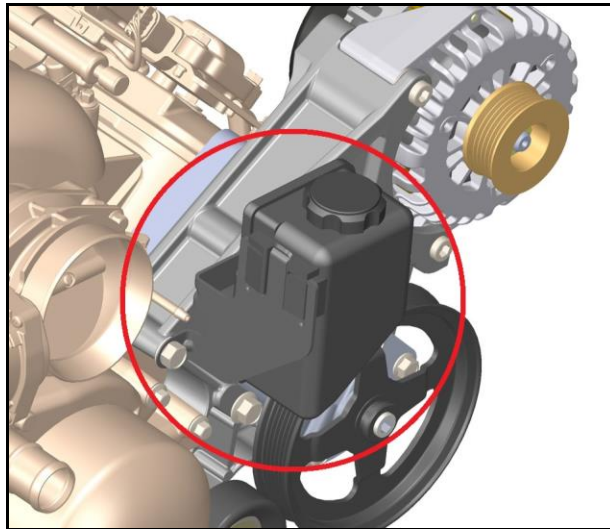
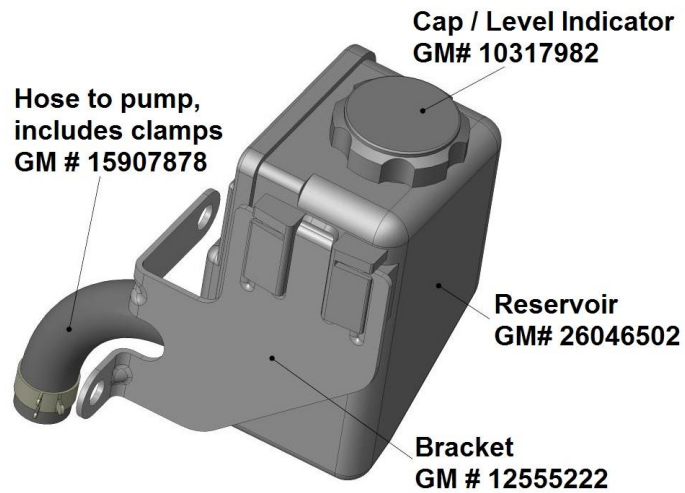

After reviewing the components needed for your specific application, parts can be sourced and the Holley kits can be installed. See the included assembly instructions for installation procedures.