

Assembly Instructions



Holley Accessory Drive Kit Part Number 20-132

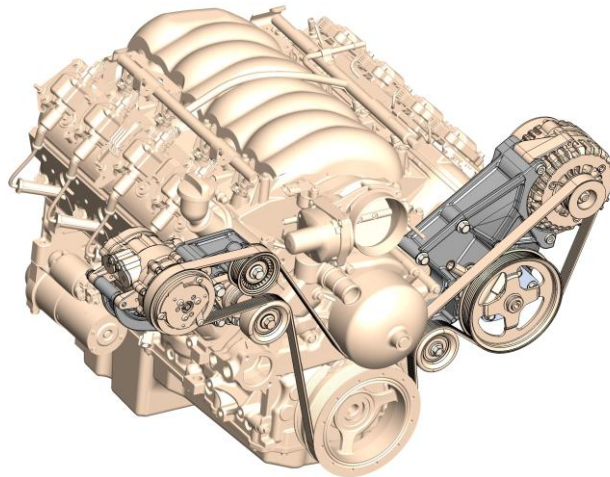

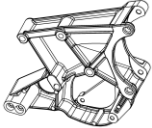
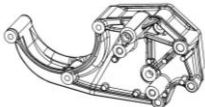
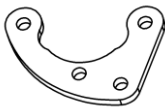

Table of Contents





Parts List:	2
Driver's Side Bracket Installation:.....	4
Power Steering Pump Installation:.....	5
Idler Pulley Installation (position options):.....	6
P/S Pulley & Alternator Installation:.....	7
Passenger's Side Bracket Installation:	8
Idler & Tensioner Installation:.....	9
A/C Compressor Installation:.....	10
Belt Routing & Length Calculation:.....	11

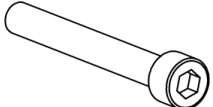
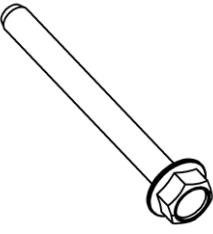

Parts List:

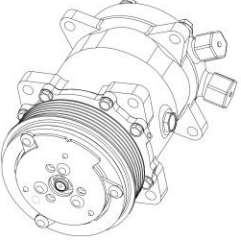
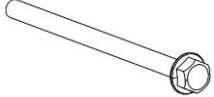
- Bracket requires application specific installation kit part # 21-1, 21-2, or 21-3

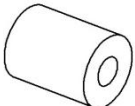
Parts included with 20-132 bracket kit (see list supplied with installation kit for additional parts):

PICTURE	QTY	DESCRIPTION	APPLICATION
	1	Driver's Side Bracket Assembly	Alternator & Power Steering Pump
	1	Passenger's Side Bracket Assembly	A/C Compressor & Tensioner
	1	Power Steering Pump Plate Bracket	Front Support of Power Steering Pump
	1	Step Spacer	Driver's Side Idler Pulley
	1	Socket Head Cap Bolt, M10 x 1.5 x 30	Spacer to Passenger's Side Head
	2	Socket Head Cap Bolt, M10 x 1.5 x 80	Alternator Bolts
	2	Flange Head Bolt, M8 x 1.25 x 20	Power Steering Pump Bolts
	2	Flange Head Bolt, M8 x 1.25 x 80	Power Steering Pump Bolts
	3	Flange Head Bolt, M8 x 1.25 x 35	Passenger's Side Bracket to Spacer
	2	Flange Head Bolt, M10 x 1.5 x 35	Tensioner Assembly to Passenger's Side Bracket
	1	Flange Head Bolt, M10 x 1.5 x 35	Idler Pulley to Passenger's Side Bracket
	1	Flange Head Bolt, M10 x 1.5 x 45	Idler Pulley to Driver's Side Bracket

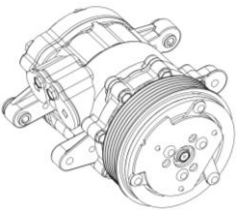
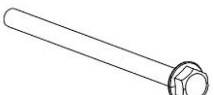
PICTURE	QTY	DESCRIPTION	APPLICATION
	USE THESE PARTS ONLY WHEN INSTALLING AN SD5 TYPE A/C COMPRESSOR (compressor not included)		
	3	Flange Head Bolt, M8 x 1.25 x 125	A/C Compressor Bolts
	3	M10 to M8 Sleeve	A/C Compressor Front Mounting Ears
	3	M8 Steel Spacer	Bracket to Rear A/C Compressor Ears
	3	M8 Flange Bushing	Rear A/C Compressor Ears
	3	Locking Nut, M8 x 1.25	Rear A/C Compressor Bolts

PICTURE	QTY	DESCRIPTION	APPLICATION
	USE THESE PARTS ONLY WHEN INSTALLING AN SD7 TYPE A/C COMPRESSOR (compressor not included)		
	2	Flange Head Bolt, M8 x 1.25 x 95	A/C Compressor Bolts
	2	M8 Thin Spacer	Bracket to Front A/C Compressor Ears

Driver's Side Bracket Installation:

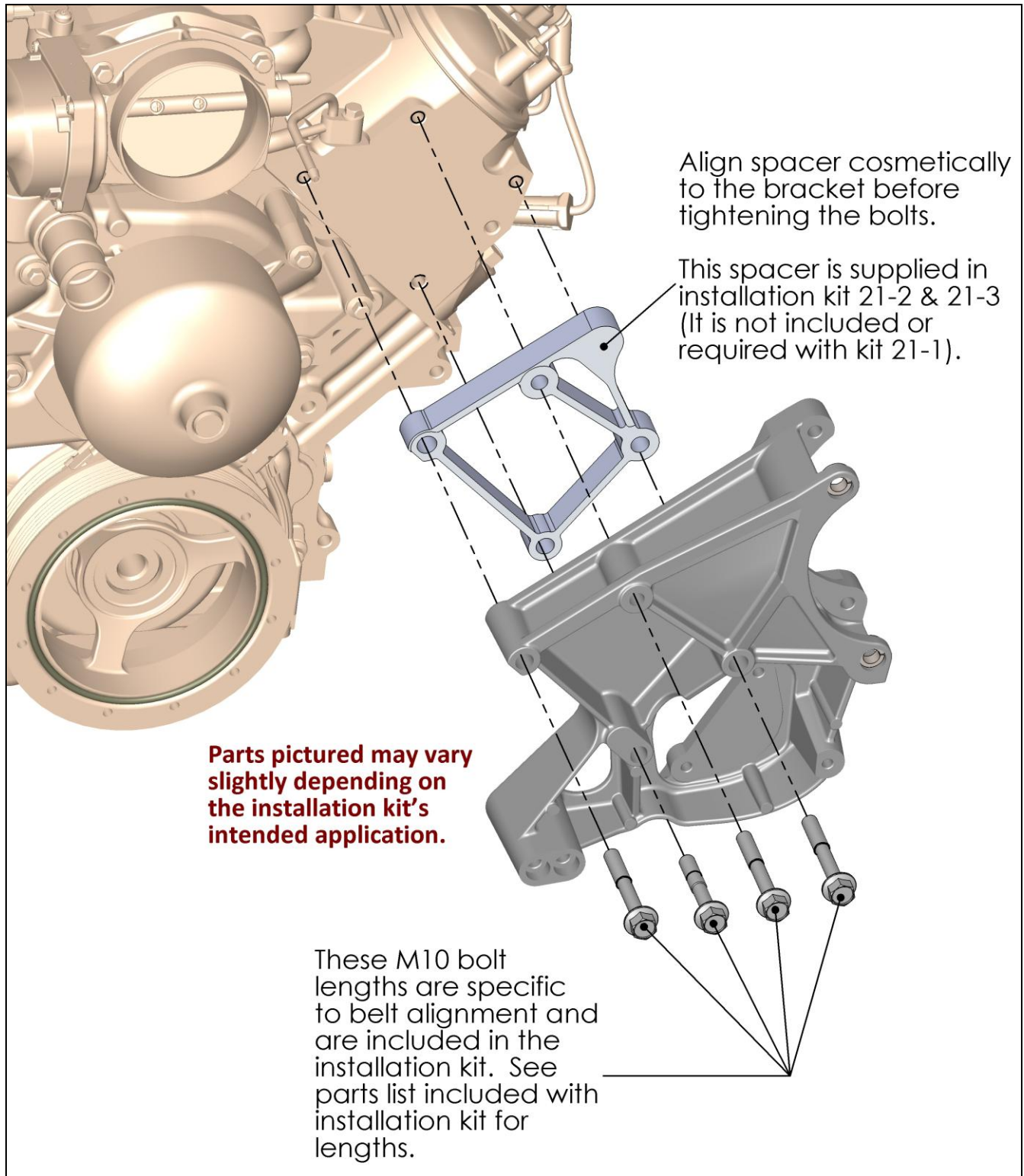

NOTE: Torque M8 bolts to 18 ft./lbs. and M10 bolts to 36 ft./lbs.

Power Steering Pump Installation:

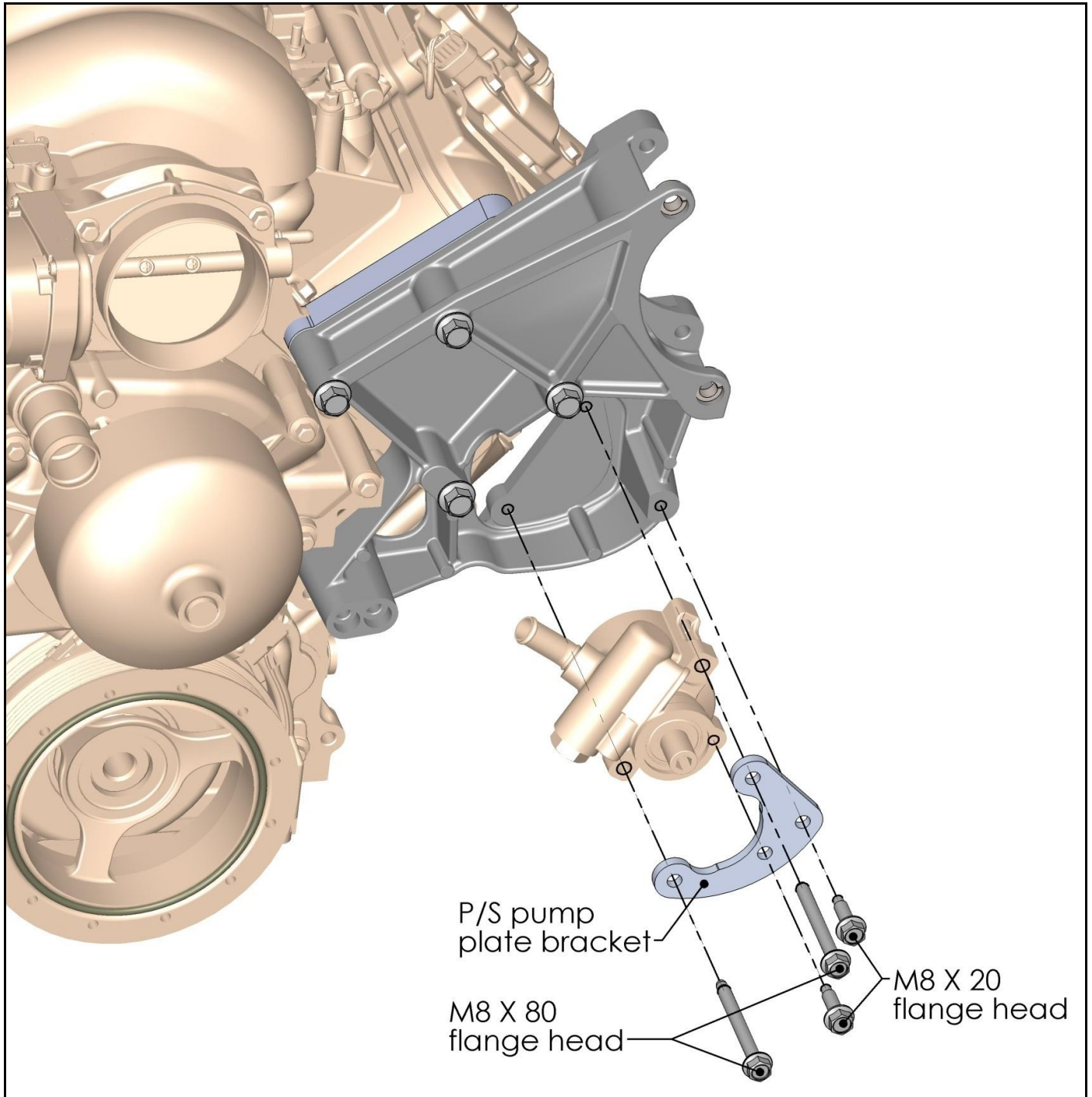

NOTE: Torque M8 bolts to 18 ft./lbs. and M10 bolts to 36 ft./lbs.

Idler Pulley Installation (position options):

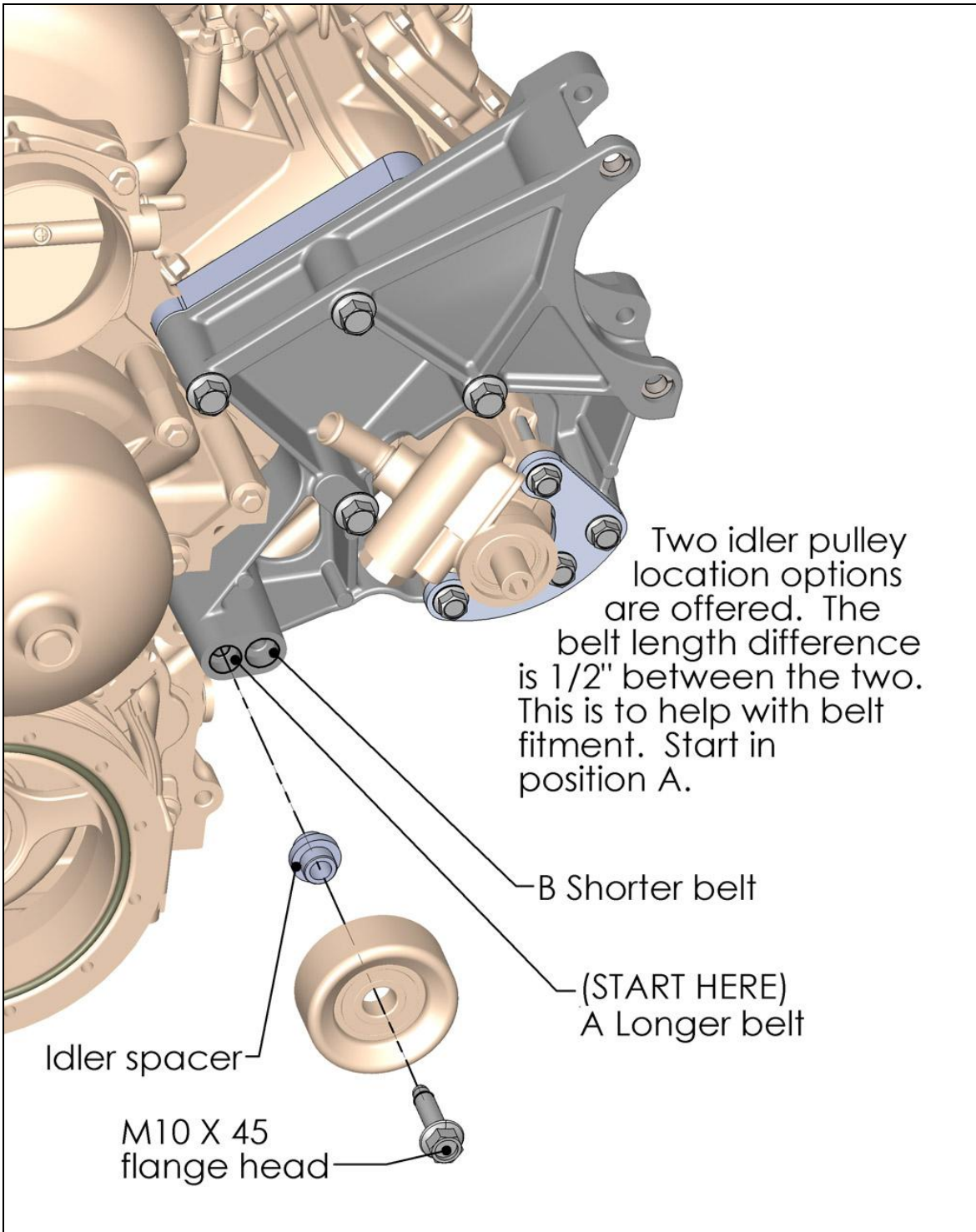

NOTE: Torque M8 bolts to 18 ft./lbs. and M10 bolts to 36 ft./lbs.

P/S Pulley & Alternator Installation:

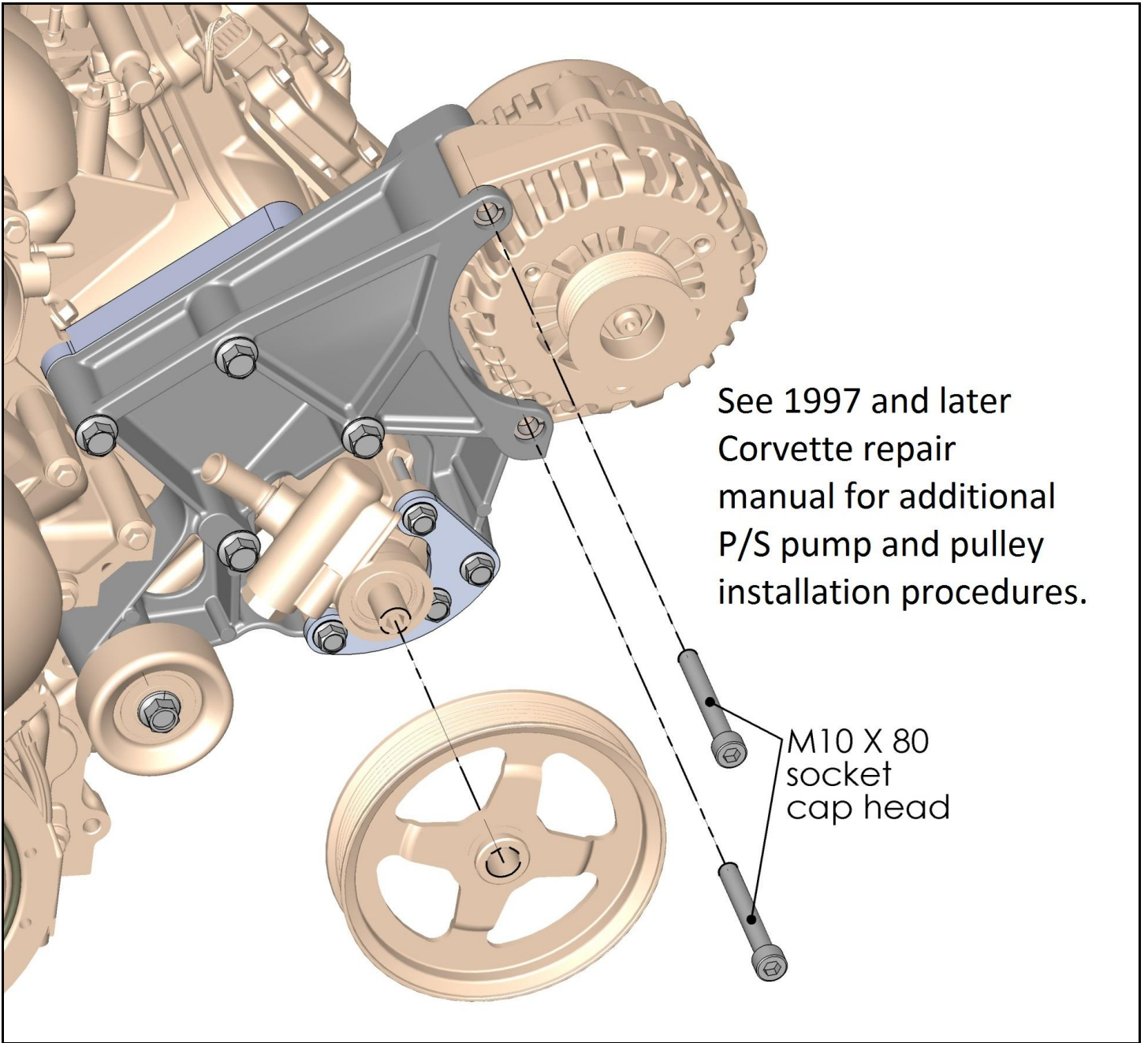

NOTE: Torque M8 bolts to 18 ft./lbs. and M10 bolts to 36 ft./lbs.

Passenger's Side Bracket Installation:

If the EVAP solenoid is located on the front of the passenger's side head, it will need to be relocated when using this A/C compressor bracket.

Parts pictured may vary slightly depending on the installation kit's intended application.

This spacer is not supplied with the bracket, but is required for installation on all applications. This spacer is supplied in the installation kit 21-1, 21-2, and 21-3.

Align spacer cosmetically to the bracket before tightening the bolts.

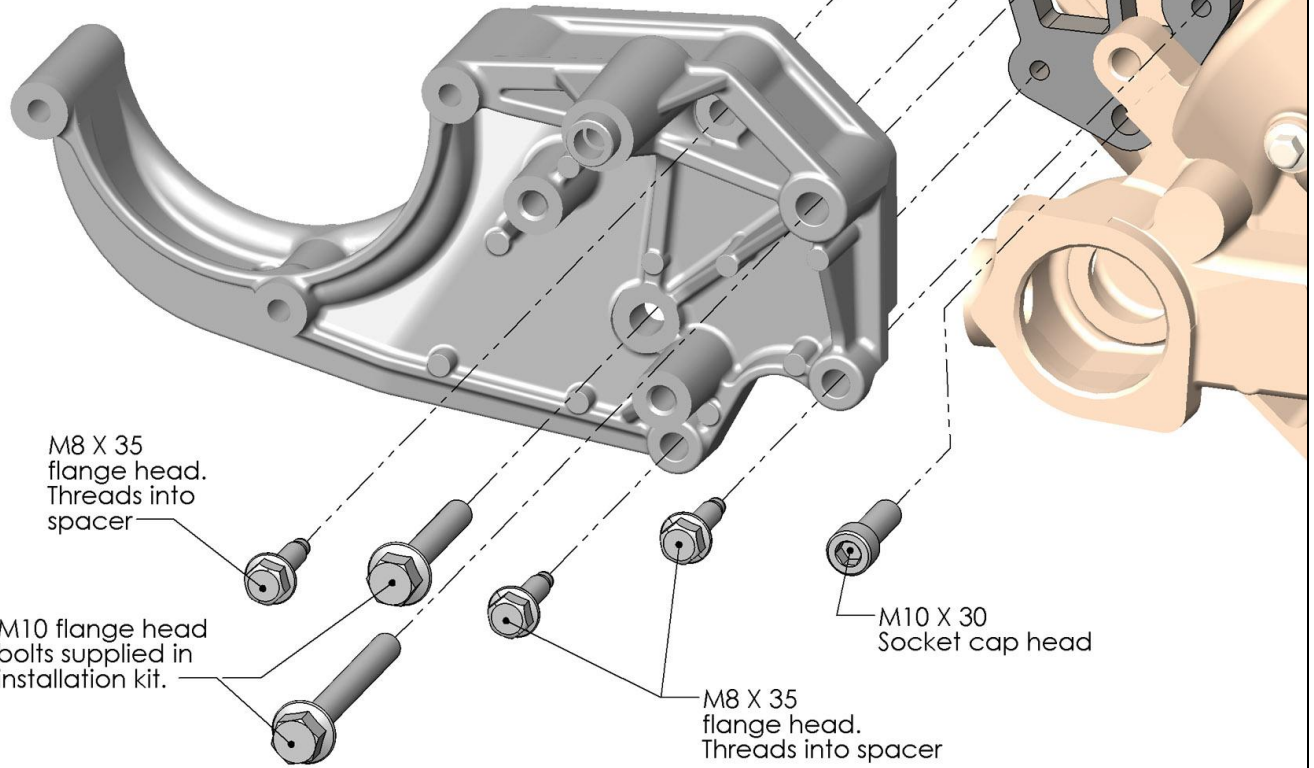

NOTE: Torque M8 bolts to 18 ft./lbs. and M10 bolts to 36 ft./lbs.

Idler & Tensioner Installation:

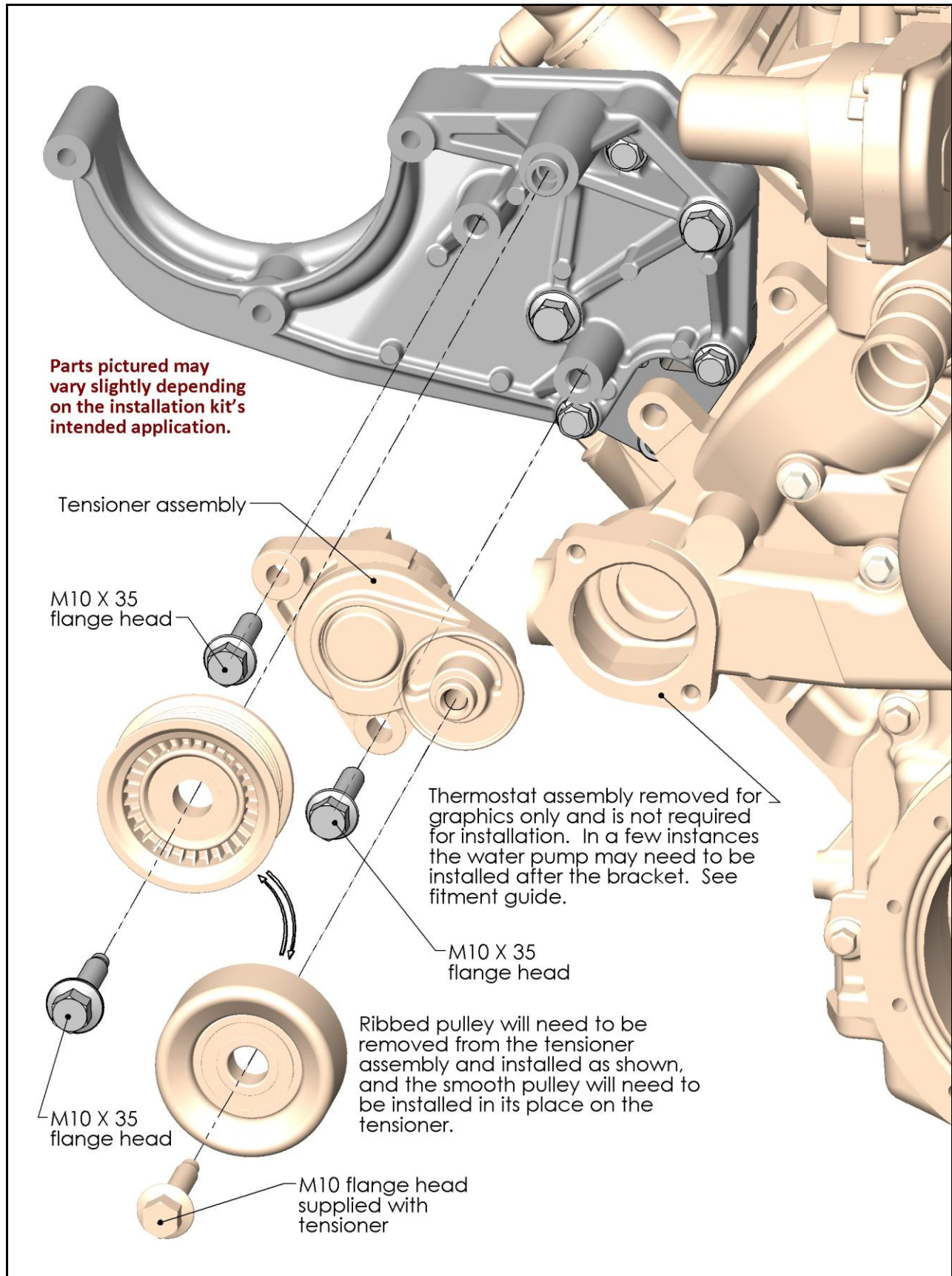

NOTE: Torque M8 bolts to 18 ft./lbs. and M10 bolts to 36 ft./lbs.

A/C Compressor Installation:

Installation step when installing an SD5 type A/C compressor

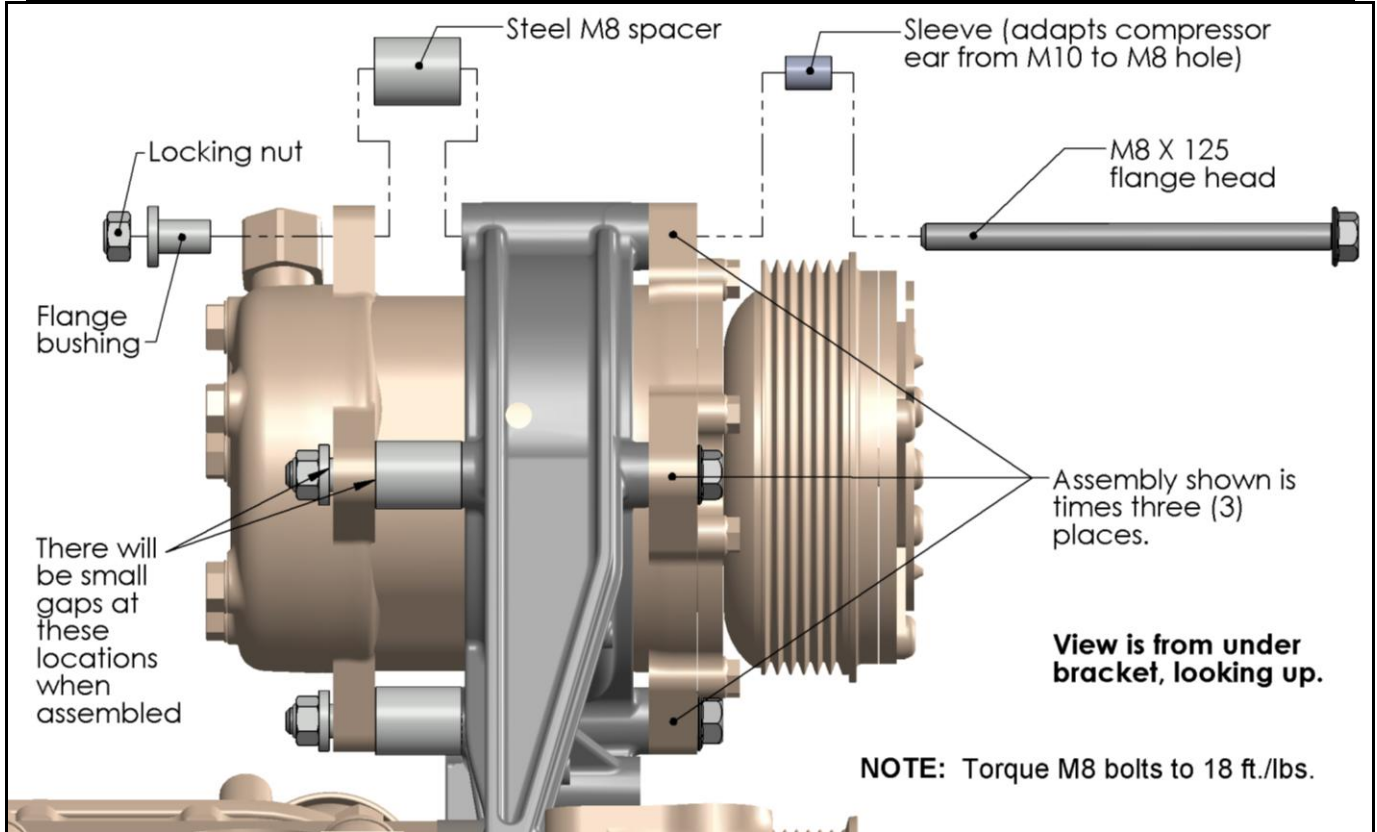

Installation step when installing an SD7 type A/C compressor

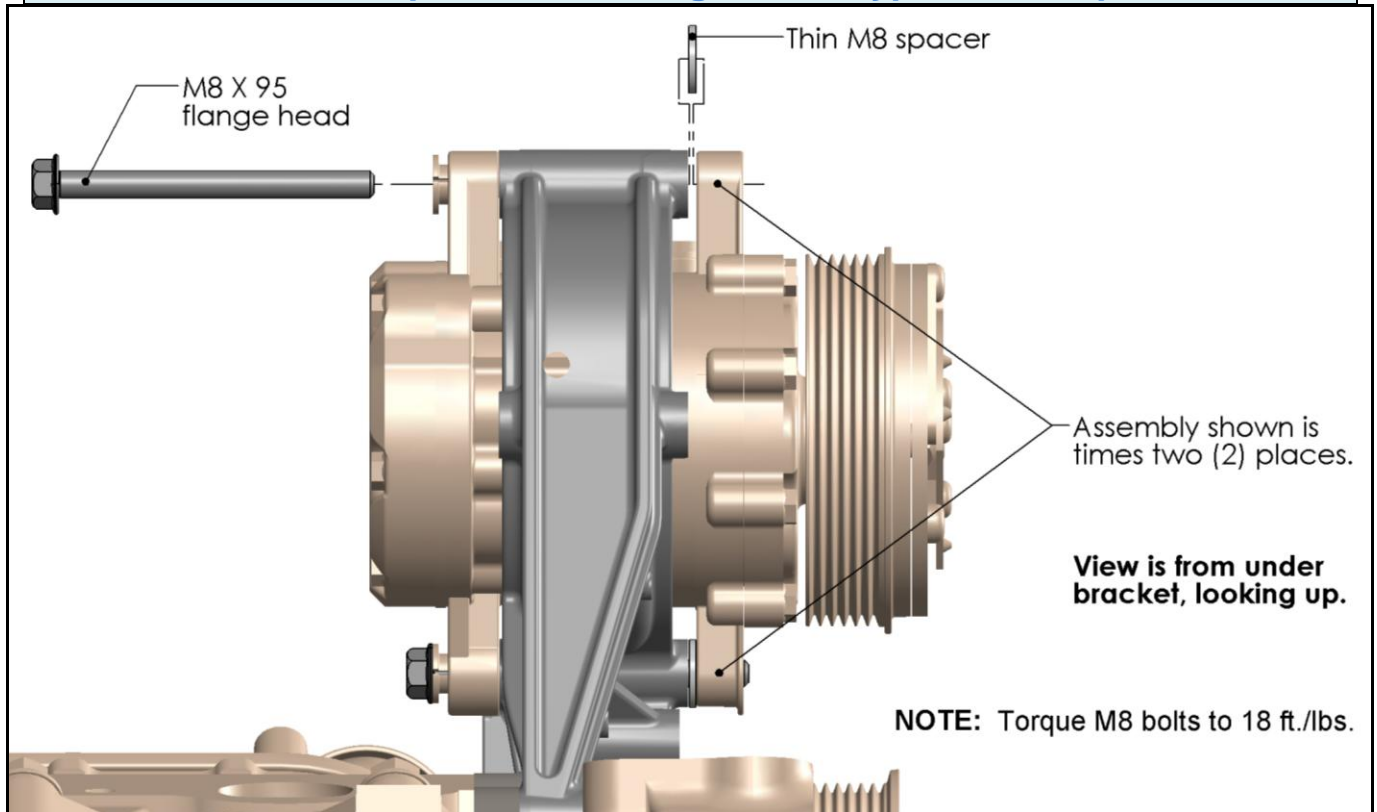

Belt Routing & Length Calculation:

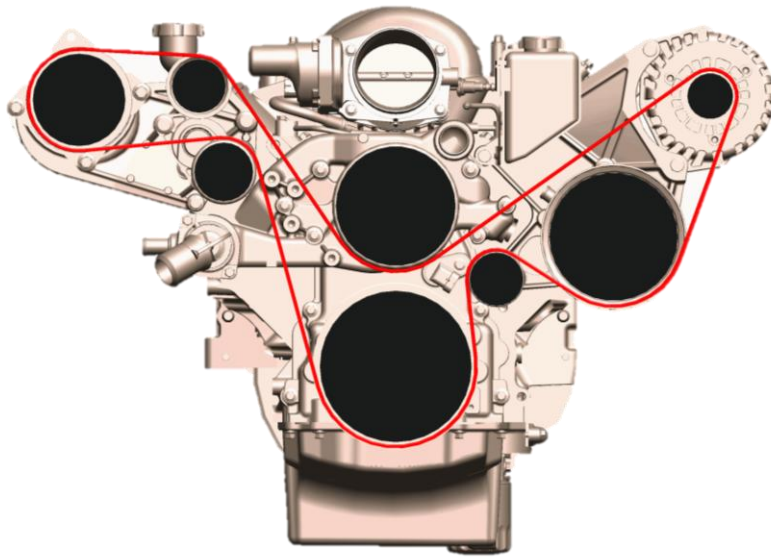

HELPFUL HINT: When installing the belt, route around all the pulleys except the water pump pulley. While fully rotating the tensioner arm, slip the belt on the smooth water pump pulley last.

Use serpentine belt part number 6PK2540 with SD5 compressor or 6PK2515 with SD7 compressor (not included in bracket kit) if using ALL Holley accessories and supplemental parts.

If you are installing a Holley bracket kit and are NOT using Holley accessories, you will have to measure to find the correct belt length as pulley diameters vary on accessories and will directly affect belt length.

To acquire this measurement, perform the following:

After all brackets and accessories are installed, route masking tape or string around the belt path. Leave the tensioner in the un-sprung position for this measurement. Mark or cut the tape/string to length and remove from the pulleys. Subtract 1 1/8" (28 mm) from the measured length to compensate for the un-sprung tensioner position. You will need to convert belt length to millimeters if measured in inches (inches X 25.4 = mm). Go to any auto parts store and ask for a 6PK0000 belt with the "0000" being the length in millimeters. For example, if you measured 2493 mm and then subtracted 28 mm, you would get 2465 mm, and the part number would be 6PK2465. Remember, if you miss on size, the driver's side idler can be moved to decrease the required belt length by 1/2".

