



12-1500 – VR1 Fuel Pump
12-767 – VR Series Quick Kit
12-768 – VR Series Quick Kit w/ 26-163 Harness
12-769 – VR Replacement Controller
Installation Instructions 199R10974

WARNING! THESE INSTRUCTIONS MUST BE READ AND FULLY UNDERSTOOD BEFORE BEGINNING INSTALLATION. FAILURE TO FOLLOW THESE INSTRUCTIONS MAY RESULT IN POOR PERFORMANCE, VEHICLE DAMAGE, PERSONAL INJURY, OR DEATH. IF THESE INSTRUCTIONS ARE NOT FULLY UNDERSTOOD, INSTALLATION SHOULD NOT BE ATTEMPTED. PLEASE CONSULT HOLLEY TECH SERVICE OR A QUALIFIED MECHANIC.

NOTE: DESIGNED FOR GASOLINE AND INTERMITTENT NON-HIGHWAY USE WITH METHANOL & E85.

APPLICATIONS:

Part Number	Compatible up to 18.5V	Application	Fuel Compatibility	GPH Flow at Rated PSI and 13.8V	Holley Recommendations for Peak Performance													Max Amp Draw
					Max HP**		Pump Fitting Size		Minimum Recommended Line Size			Fuel Filter (Carbureted)		Fuel Filter (Fuel injected)		Recommended Regulator		
					Naturally Aspirated	Forced Induction	Inlet	Outlet	Inlet	Outlet	Return	Pre	Post	Pre	Post	Carb	EFI	
The pumps below do not have an internal bypass. A bypass style regulator and return line are required.																		
12-1500	Yes	Race Street/Strip	Pump Gas, Race Gas, Methanol*, E-85*	162 @ 8 PSI 138 @ 43 PSI 126 @ 60 PSI 87 @ 130 PSI	2400 2150 2000 1500	1800 1650 1500 1000	10AN O-Ring	10AN O-Ring	-10AN	-10AN	-8AN	162-577	162-576	162-577	162-575	12-852 12-865	12-851 12-864	19 Amps
*Compatible for methanol and E85 for competitive drag race use only- when draining and flushing after each race event																		
** HP estimates are based on gasoline. Estimates calculated at 18.5V and at .5 BSFC NA and .65 BSFC FI. Individual systems will vary based on fuel system design, regulator type, fuel cell location, launch G's, etc.																		

PARTS REQUIRED FOR INSTALLATION:

- Pre-Filter & Post-Filter
- Relay Kit (30 amp minimum) – Holley P/N 12-753 or equivalent
- Fuel hose & fittings (10 AN O-ring)
- Wire & connectors
- Mounting hardware

NOTE: These pumps are not serviceable in the field. Contact Holley tech service for fuel pump service.

INTRODUCTION:

Congratulations on your purchase of the **Holley VR1 Fuel Pump**. This instruction sheet contains all the information needed to install this fuel pump. Please read all the **WARNINGS** and **NOTES**. They contain valuable information that can save you time and money. Holley Performance Products cannot and will not be responsible for any alleged or actual engine or other damage, or other conditions resulting from misapplication of the fuel pumps and fuel pressure regulators described herein. However, it is our intent to provide the best possible products for our customer; products that perform properly and satisfy your expectations. Should you need information or parts assistance, please contact Technical Service at 1-270-781-9741, M-F, 8 a.m. to 6 p.m. & Sat. 9 a.m. to 3 p.m. CST. Please have the P/N ready when calling.

NOTE: A screen type pre-filter (100 micron – P/N 162-577), a top quality post fuel filter (carbureted 162-576 or fuel injected 162-575), fuel hose and clamps, 12 gauge wire, fuel fittings, assorted terminals. A relay kit like (12-753) is required to complete the installation of the Holley VR1 fuel pump. These parts are not included with the fuel pump.

NOTE: These Holley VR1 fuel pumps require the use of a bypass style fuel pressure regulator (P/N 12-852 for the 2-port & 12-865 for the 4-port) for carbureted applications and (P/N 12-851 for the 2-port & 12-864 for the 4-port) for EFI applications.

NOTE: The Holley VR1 fuel pump utilizes a 7/8-14 O-ring (10AN) inlet port & 7/8-14 O-ring (10AN) outlet port. These ports are not pipe threads, therefore **do not use thread sealant**.

PUMP MOUNTING AND INSTALLATION:

The best location for mounting any electric fuel pump is the rear of the vehicle, near the fuel tank and in a position even with or below the bottom of the tank, allowing the fuel to be gravity fed to the pump. **The pump should be mounted on a solid member, such as the chassis, with the pump outlet pointing forward.** Avoid exposure of the pump and fuel lines to moving parts and to any hot areas, such as the exhaust manifold. The pump should not be mounted in an enclosed area, such as the vehicle's trunk. Follow the steps below for mounting the pump.

WARNING! THE PUMP MUST BE PLACED WHERE INTERFERENCE BETWEEN THE VEHICLE'S BODY AND ITS CHASSIS MOVEMENT IS AVOIDED. THE PUMP AND ITS CONNECTING HOSES MUST NOT BE SUBJECTED TO LOW GROUND CLEARANCE, WHERE ANY FLYING ROCKS OR ROAD DEBRIS CAN CAUSE DAMAGE. FAILURE TO AVOID THESE HAZARDS WILL LEAD TO PUMP DAMAGE, WHICH COULD RESULT IN FIRE AND/OR PROPERTY DAMAGE, SERIOUS INJURY, AND/OR DEATH.

1. Select a mounting site as close as possible to the fuel tank and away from possible sources of heat as detailed previously.
2. Templates of the pump and controller mounting holes are included on the last page. Use the included paper template and drill (x4) 1/4 holes for the pump and (x4) #8-32 holes for the controller.
3. Mount the pump (outlet pointing forward) using (x4) 1/4 bolts (not included). Mount the controller using (4) #8-32 bolts (not included).

NOTE: To ensure pump life and flow efficiency, a 100 micron pre-filter must be installed between the tank and the pump inlet. The filter should be supported in such a manner that it does not hang from the fuel lines. Pre and Post filters can be mounted directly to the pump if space allows.

4. Install the recommended AN fuel fittings. (Refer to the chart on page 1 for minimum recommended fuel fitting and hose size)

WARNING! This pump is not designed to use a standard conical seat style union in the inlet or outlet of the pump. Example: Part # AT981510ERL (Figure 1). Use of this style fitting will restrict flow and WILL lead to poor performance and potential pump failure. The ONLY correct fitting to use is a contoured port fitting with an O-ring seal such as Part # AT985010ERL (Figure 2).



Figure 1



Figure 2

5. Connect the fuel supply line from the tank to the pre-filter and then to the inlet port of the pump. Connect the main fuel feed line to the outlet port of the pump, then to the post filter. See Figures 4a and 4b.

NOTE: Avoid unnecessary restrictions, such as sharp bends and undersized fuel fittings and hoses. Avoid routing fuel lines in areas that would cause chafing. All fuel line connections must be leak proof.

WARNING! IF SPLICING INTO EXISTING FUEL LINES, USE EXTREME CARE TO AVOID CONTAMINATING THE LINE WITH RUBBER OR METAL SHAVINGS, AS THIS WILL DAMAGE THE PUMP. IF THE FUEL LINE HAS BEEN CUT, IT IS ESSENTIAL THAT IT BE CLEANED TO ENSURE THAT NO METAL OR RUBBER PARTICLES ENTER THE FUEL SYSTEM. THIS IS PERFORMED BY BLOWING THE LINE CLEAN WITH COMPRESSED AIR. HOLLEY DOES NOT RECOMMEND THE PROCEDURE WHERE THE COIL WIRE IS DISCONNECTED, THE ENGINE IS CRANKED, AND THE FUEL IS COLLECTED IN A CONTAINER. SPARKING CAN OCCUR DURING THIS PROCEDURE, WHICH MAY RESULT IN A FIRE AND/OR EXPLOSION.

WARNING! DO NOT OVER TIGHTEN THE FITTINGS ON THE FUEL PUMP. TORQUE the fittings in the pump as follows. (-10AN to 360-430 in. /lbs., -8AN to 270-300 in. /lbs. and -6AN to 150-170 in. /lbs.)

USING A FUEL PRESSURE REGULATOR WITH THE VR1 FUEL PUMP:

NOTE: A return style fuel pressure regulator is required for use with the Holley VR1 fuel pumps. Please refer to the chart on page one for recommended fuel pressure regulators. Refer to figures 1a and 1b for recommended plumbing scenarios.

NOTE: Refer to the installation instruction included with the fuel pressure regulator for steps on mounting and adjustments.

NOTE: Depending on your application, choose one of the following examples:

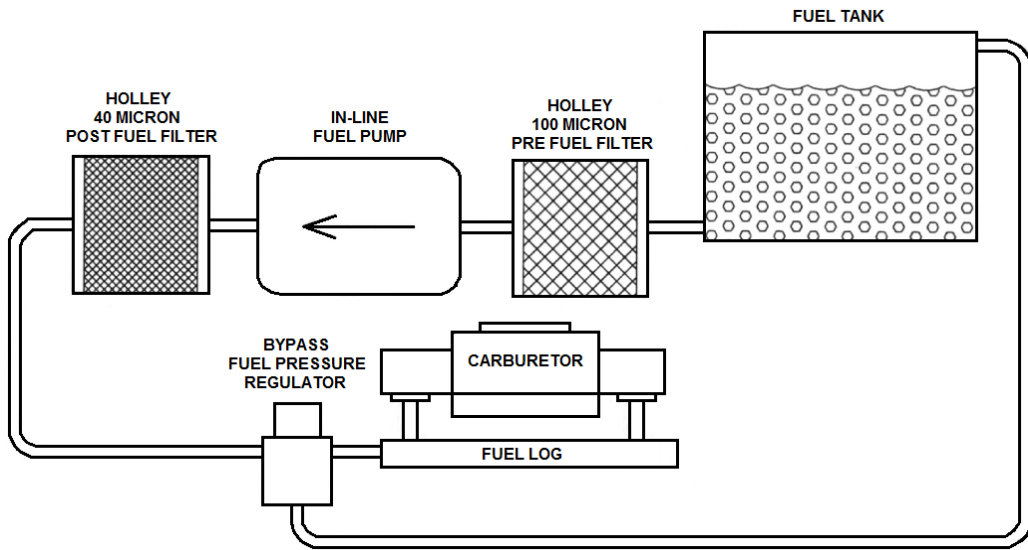

Figure 4a (Carb applications only)

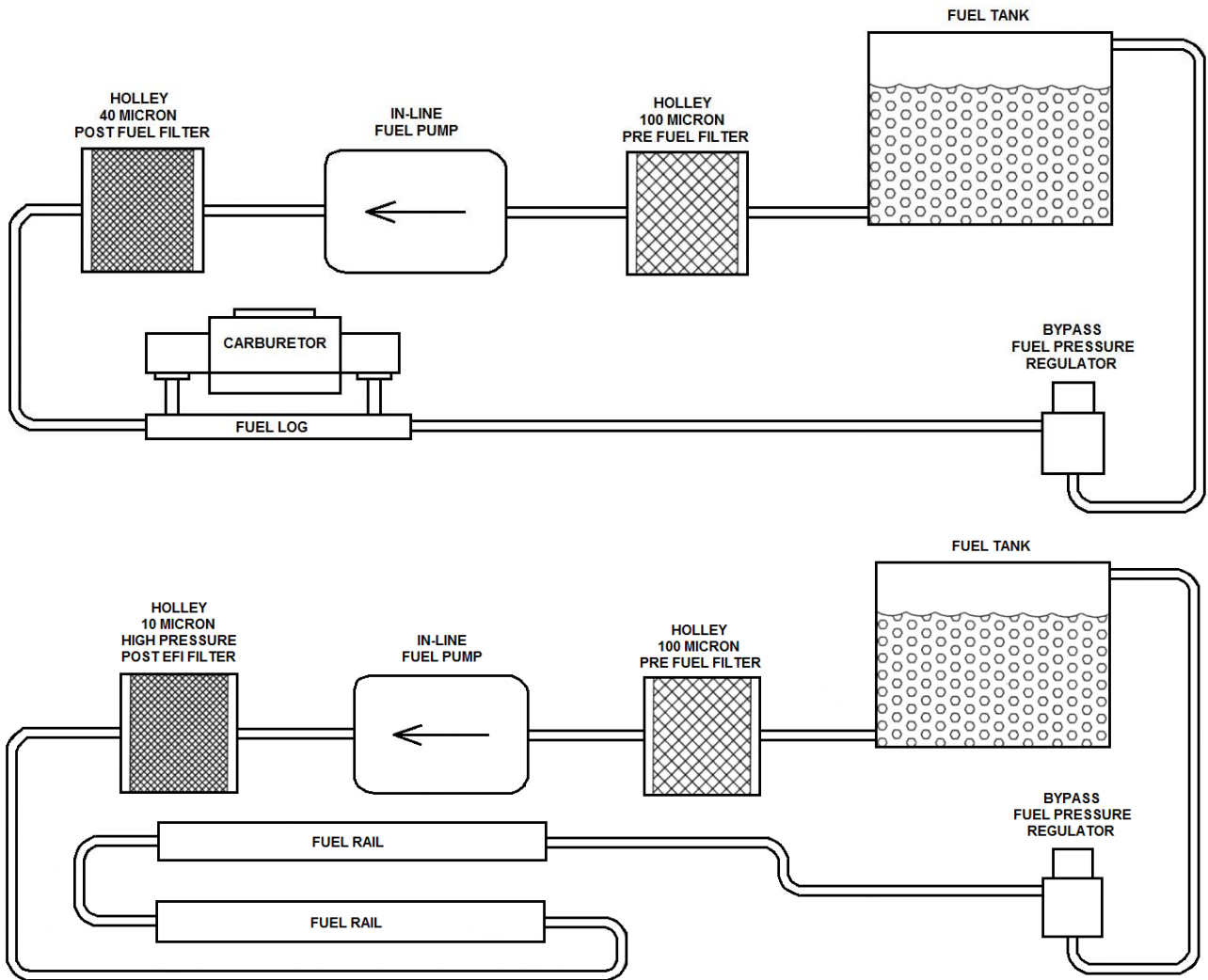

Figure 4b (Both carb & fuel injection applications)

INTRODUCTION:

The Holley BLDC (Brushless DC Controller) is primarily designed to be used in conjunction with the Holley VR1 fuel pump. The controller is designed to operate stand-alone or to be used as a slave device via a ground input.

OPERATION:

The BLDC has three (3) inputs: (Red) power, (Black) ground, and (Yellow) signal. The signal wire controls how the BLDC controls the fuel pump.

100% Duty Cycle Setup:

The first configuration, which is the simplest mode, is the controller operates the fuel pump at 100% duty cycle based on a single binary input. (The yellow signal wire is not used). The schematics in Figure #5 and #6 show this installation. These schematics will guide you for the controller installation with relays.

50% Duty Cycle Setup:

In a typical usage the controller would be in the 50% duty cycle mode (Yellow input signal wire to ground). This configuration would allow the user to control the fuel pump duty cycle from 50% to 100% via a grounding input. Any switch or triggering device can be installed in line between the yellow wire and ground. As long as it can provide a ground at low demand and remove that ground at high demand, it can operate the controller. This could be done by a toggle switch, TPS switch, any aftermarket EFI system, a nitrous controller, etc...

An example would be once the (TPS) throttle is depressed to a user set position the switch would disengage ("open") the ground signal and command the controller into a 100% duty cycle mode.

****Since there are many signal methods that can be used, please refer to the schematics of the particular switch or triggering system that you are using to verify the (yellow) signal wire connections.**

We will cover using this controller in conjunction with the Holley EFI system in the setup section on page 5.

WIRING:

WARNING! USE A MINIMUM OF 12 GAUGE WIRE. BE SURE TO CRIMP OR SOLDER ALL CONNECTORS SECURELY AND CLEAN ANY AREA WHERE GROUND LEADS WILL BE FASTENED. FAILURE TO USE THE MINIMUM WIRE GAUGE COULD RESULT IN A PUMP MALFUNCTION AND/OR ELECTRICAL FIRE, RESULTING IN PROPERTY DAMAGE, SERIOUS INJURY, AND/OR DEATH.

WIRING THE FUEL PUMP WITH A RELAY:

NOTE: You will need Holley Fuel pump relay kit P/N 12-753 or equivalent 4-wire relay.

1. Disconnect the cables from the battery.
2. Mount relay on firewall of engine compartment or other suitable location using a sheet metal screw.

WARNING! Before punching or drilling a hole in the firewall, make sure you know what is on the other side to avoid puncturing equipment such as heater cores, air-conditioning system equipment, hoses, or wiring.

3. Plug the fuel pump relay harness into the relay, until it locks into place.
4. If using a Holley relay, connect the black wire of the relay harness to a good clean ground using 12 gauge wire.
5. Connect the Green/Black wire of the relay harness to a switched 12V source.
6. Connect one of the red wires of the relay harness to the positive wire (red wire) of the controller.
7. Connect the black wire of the controller to a good clean chassis ground using a ring terminal.
8. Attach the in-line fuse holder to the remaining red wire. After attaching the fuse holder, insert a 25A fuse and connect to the positive side of the battery using 12 gauge wire.
9. Connect the controller fuel pump harness to the fuel pump harness.
10. Reconnect the battery cables.

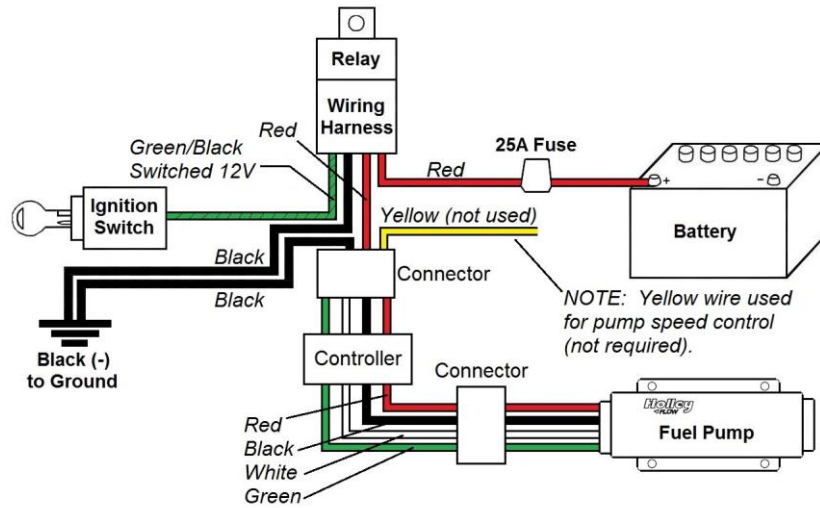

Figure 5

SETUP:

If using this pump in conjunction with the Holley EFI System, please refer to the following setup instructions:

The BLDC pump runs at 50% duty cycle when the (yellow) wire is grounded. Holley EFI software has logic built in that allows seamless, automatic speed control of the pump between 50% and 100%.

To set this up, create a new output in the I/O (inputs/outputs) ICF

NOTE: If your calibration does not have the I/O ICF, you can add it by following these steps:

1. Select Toolbox and choose “Add Individual Config” from the drop down menu



2. Next, choose the “IO” folder and open “Base Config – Blank.io”

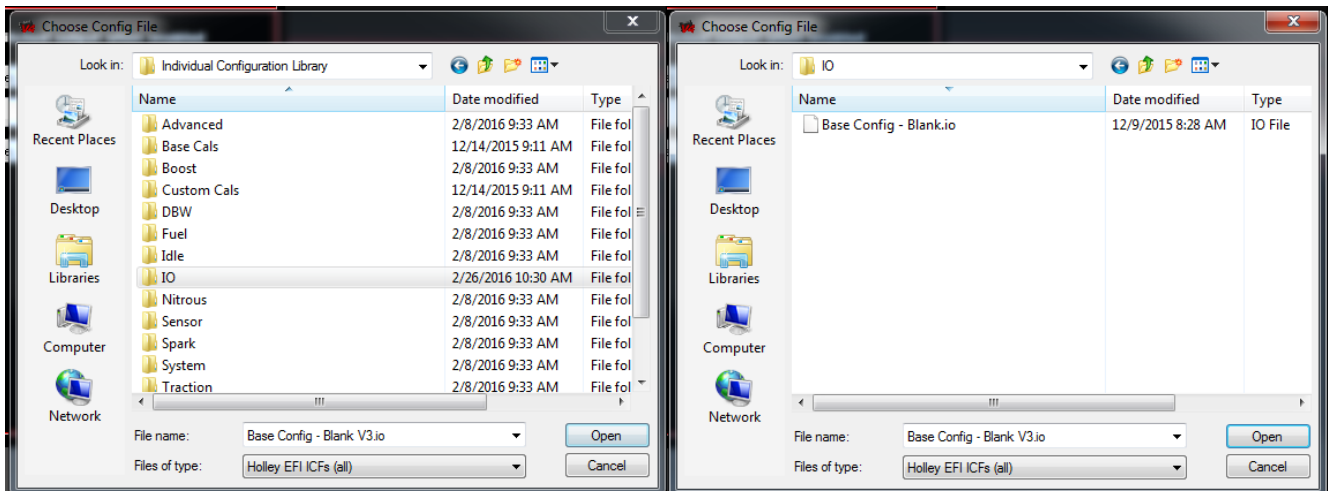

3. At this point, you should have an icon for custom inputs/outputs configuration:



Configure any available output (#1 in this example) and name it BLDC 50% DUTY as shown below, then select Configure. Ensure the output is configured as "GROUND". Otherwise, damage can occur to the controller.



In this example configuration, the pump would run at 50% duty cycle when fuel flow is between 0 and 400 lb/hr. Above 400 lb/hr the ground output would be deactivated and the pump would run at 100%.

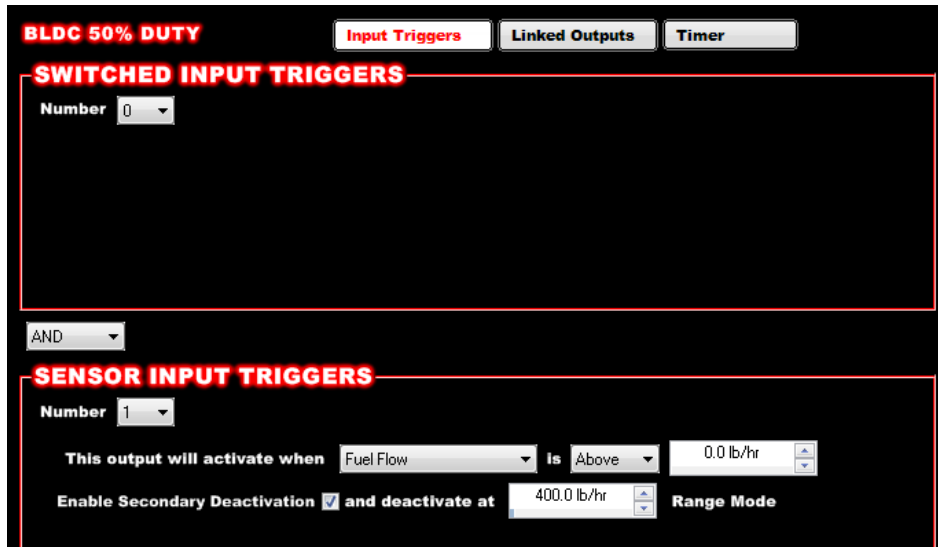

In this example configuration, the pump would run at 50% duty cycle when MAP is between 0 and 135 kPa (5 psi boost). Above 135 kPa the ground output would be deactivated and the pump would run at 100%.

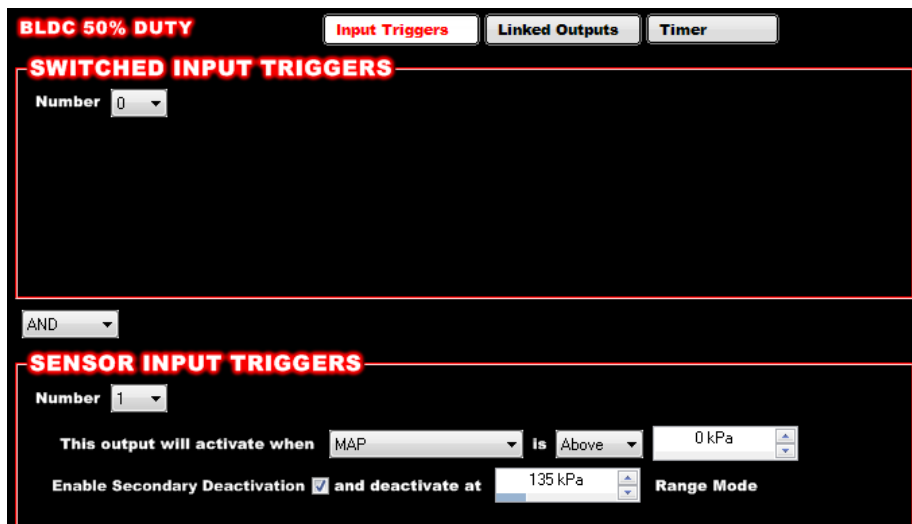

In this more advanced example, the pump would run at 50% duty cycle as long as:

1. Nitrous is NOT enabled
OR
2. TPS is between 0 and 50%

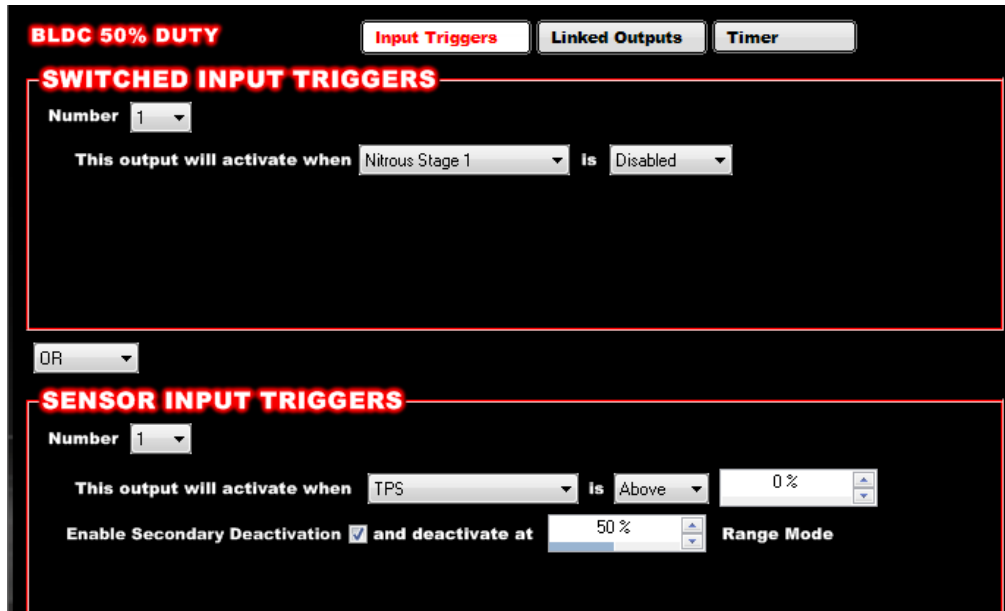

In this example, the pump would run at 100% duty cycle as soon as a Water/Meth solenoid is turned on:

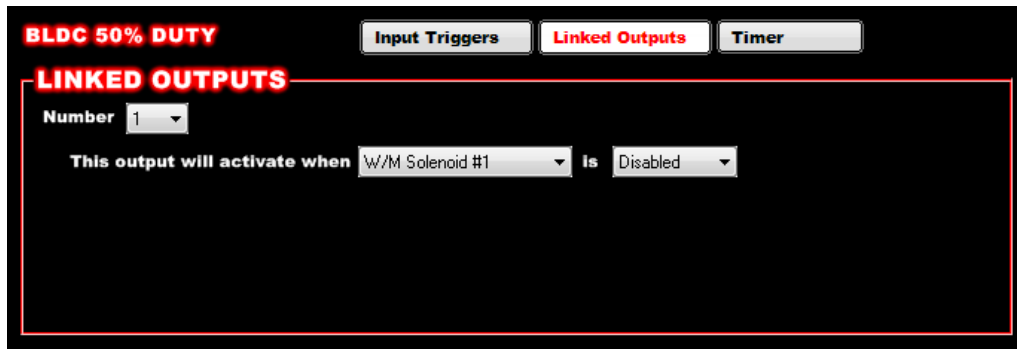

The same type of logic could be applied to operate the 12-3000 or 12-3000-2 pumps in the following configurations:

- Pump 1 at 50% -- Pump 2 off
- Pump 1 at 100% -- Pump 2 off
- Pump 1 at 100% -- Pump 2 at 50%
- Pump 1 at 100% -- Pump 2 at 100%

For more setup up options, refer to the instructions with your Holley EFI system or contact Holley Tech Services.

SERVICE PARTS AND ACCESSORIES:

ITEM	PART NUMBER
Chevy Small Block Mechanical Pump Block-Off Plate	12-814
Chevy Big Block Mechanical Pump Block-Off Plate	12-813
0-15 PSI Fuel Pressure Gauge (non-liquid filled) 1-1/2" Dia. 1/8" NPT	26-500
0-30 PSI Fuel Pressure Gauge (non-liquid filled) 1-1/2" Dia. 1/8" NPT	26-502
0-15 PSI Electric Fuel Pressure Gauge (dash mount)	26-503
0-15 PSI Fuel Pressure Gauge (liquid filled) 1-1/2" Dia. 1/8" NPT	26-504
0-30 PSI Fuel Pressure Gauge (liquid filled) 1-1/2" Dia. 1/8" NPT	26-505
0-160 PSI Fuel Pressure Gauge (liquid filled) 2" Dia. 1/8" NPT	26-506
30AMP Fuel Pump Relay Kit	12-753
90° Elbow for Attachment to Holley Fuel Line	26-69

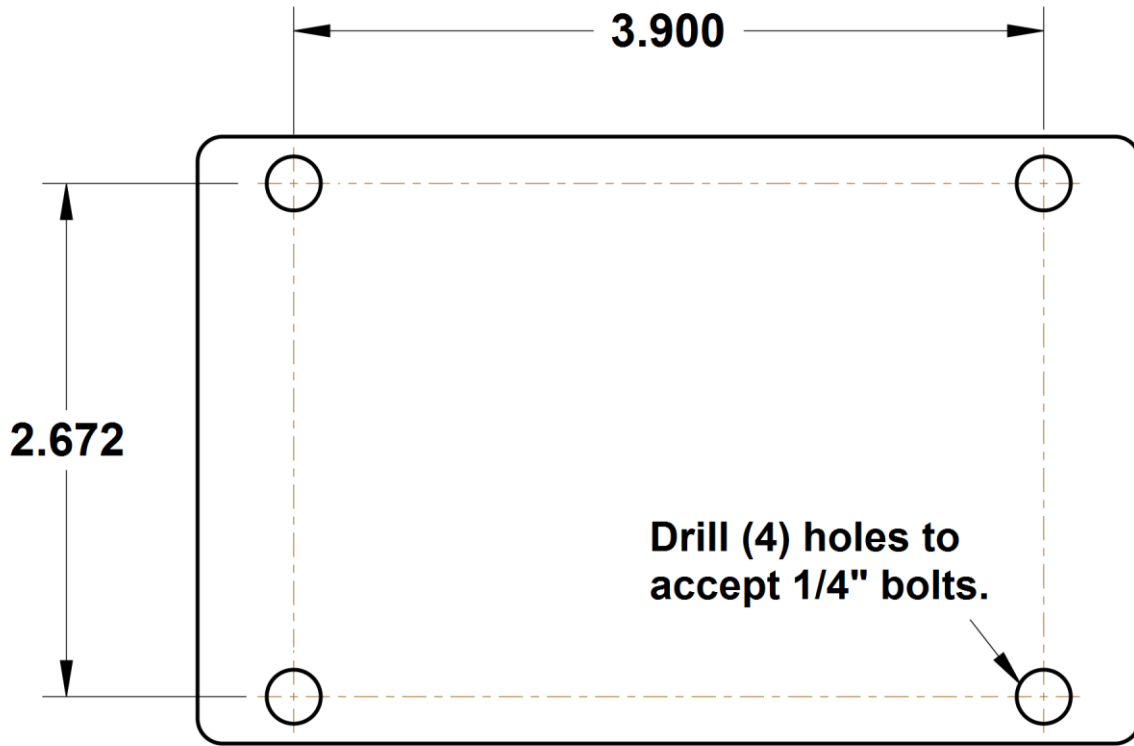

Fuel Pump Template

