



## OEM Tank Hanger Instructions

|        |                                                    |
|--------|----------------------------------------------------|
| 12-300 | 67-69 Camaro/Firebird                              |
| 12-301 | 70-73 Camaro/Firebird                              |
| 12-302 | 65-67 Chevelle/Malibu/Station Wagon                |
| 12-303 | 68-72 Chevelle/El Camino/Sprint; 70-72 Monte Carlo |
| 12-304 | 74-81 Camaro/Firebird                              |
| 12-306 | 78-88 GM G Body                                    |
| 12-307 | 70-86 CJ Jeep                                      |
| 12-308 | 73-86 GM CK Truck                                  |
| 12-309 | 55-57 Chevy Exc. Wagon                             |
| 12-311 | 68-74 Corvette                                     |
| 12-312 | 75-77 Corvette                                     |
| 12-313 | 78-81 Corvette                                     |
| 12-314 | 68-70 Mopar B Body                                 |
| 12-315 | 62-65 Nova / Chevy II                              |
| 12-316 | 66-67 Nova / Chevy II                              |
| 12-317 | 61-64 Impala, Biscayne, Bel Air                    |
| 12-318 | 70-74 Cuda / Challenger                            |
| 12-319 | 64-76 Mopar A Body                                 |

### Tools Needed: Philips Head Screwdriver & In-Lb Torque Wrench

1. Install supplied HydraMat onto the pump using the alignment dowel to locate. Press firmly to seat.
2. Remove the two screws holding the fuel level sender onto the assembly. *Note: 12-312 does not require the fuel level sender to be removed.*

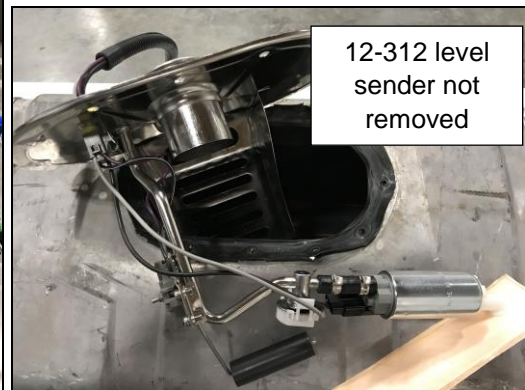
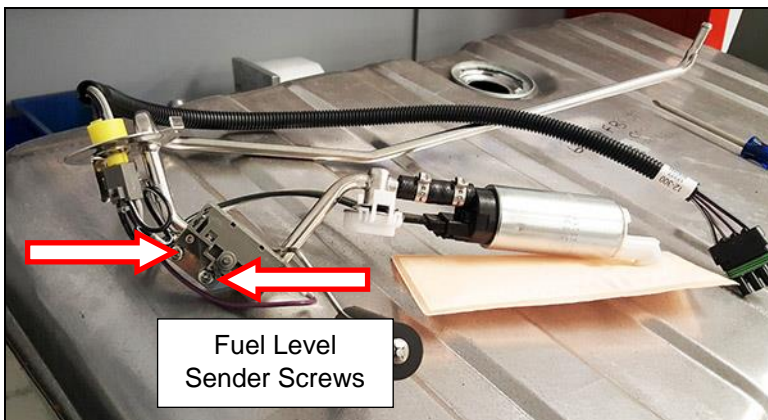

Figure 1

3. Insert the HydraMat and Pump assembly into the tank leaving the fuel level sender exposed. Be sure to insert the long end of the HydraMat into the tank first when you get to the two screw holes for the level sender then insert the sender into the tank starting with the float and secure with mounting screws. Torque to  $23 \pm 3$  in-lbs. *Note: 12-312 does not require the fuel level sender to be removed.*

**NOTE:** Be sure not to tear the HydraMat as it is being inserted into the tank.

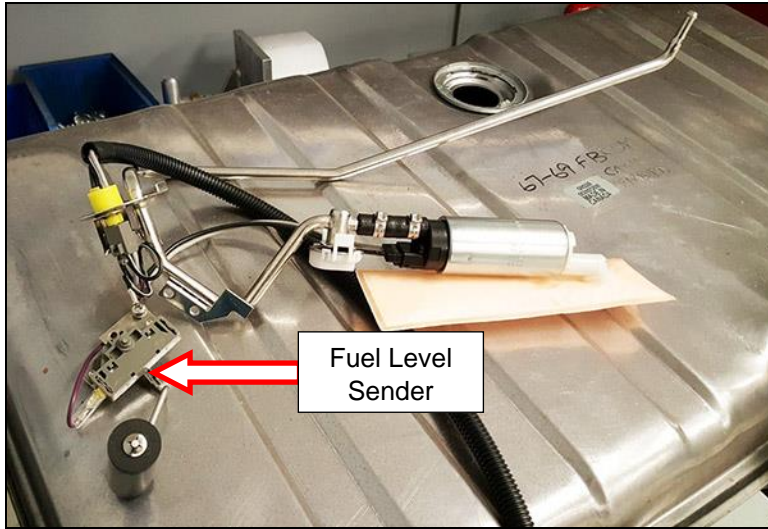

Figure 2



Figure 3



Figure 4



Figure 5



Figure 6



4. Run the supplied O-ring gasket over the supply tube and wires and stretch around the bulkhead plate (**Figure 7**).  
*Note: 12-312 and 12-313 may have the gasket installed before the fuel level sender.*



**Figure 7**

5. Seat bulkhead plate on gasket and secure with locking ring (**Figure 8**). *Note: 12-309, 12-312 and 12-313 utilize bolts in place of the locking ring. (bolts torqued to  $33 \pm 1$  in-lbs.)*



**Figure 8**

## WIRING:

**WARNING! USE A MINIMUM OF 12 GAUGE WIRE. BE SURE TO CRIMP OR SOLDER ALL CONNECTORS SECURELY AND CLEAN ANY AREA WHERE GROUND LEADS WILL BE FASTENED. FAILURE TO USE THE MINIMUM WIRE GAUGE COULD RESULT IN PUMP MALFUNCTION AND/OR ELECTRICAL FIRE, RESULTING IN PROPERTY DAMAGE, SERIOUS INJURY, AND/OR DEATH.**

1. Disconnect the cables from the battery.
2. Mount relay/relays in convenient location away from exhaust heat.
3. Plug the fuel pump relay harness into the relay, until it locks into place.
4. Connect the black wire of the harness to ground.

**NOTE: Be sure to route all electrical wires clear of any moving suspension or drivetrain components and any exhaust components! Protect wires from abrasion and road obstructions or debris.**

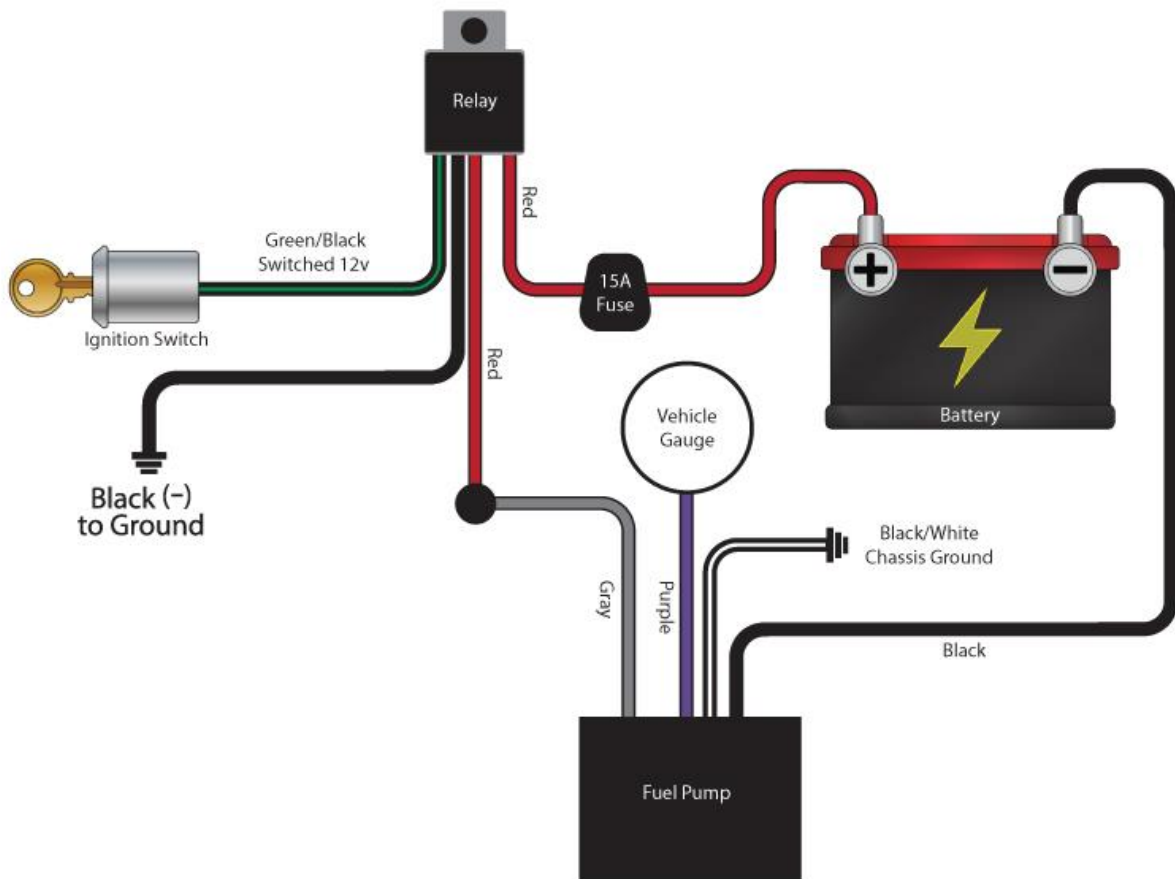

## Plumbing Note:

If connecting to factory vehicle fuel hard lines make sure that any rubber hose and clamps used are rated for EFI pressures.