



Fuel Pump Retrofit Inlet Conversion Kits

12-1601, 12-1602, 12-1801, 12-1802, 12-3001, & 12-3002

WARNING! THESE INSTRUCTIONS MUST BE READ AND FULLY UNDERSTOOD BEFORE BEGINNING INSTALLATION. FAILURE TO FOLLOW THESE INSTRUCTIONS MAY RESULT IN POOR PERFORMANCE, VEHICLE DAMAGE, PERSONAL INJURY, OR DEATH. IF THESE INSTRUCTIONS ARE NOT FULLY UNDERSTOOD, INSTALLATION SHOULD NOT BE ATTEMPTED. PLEASE CONSULT HOLLEY TECH SERVICE OR A QUALIFIED MECHANIC.

INTRODUCTION:

Congratulations on your purchase of the Holley Fuel Pump Retrofit Inlet Kit. Please read all the WARNINGS and NOTES along with familiarizing yourself with the product diagram for your pump application. They contain valuable information that can save you time and money. Holley Performance Products cannot and will not be responsible for any alleged or actual engine or other damage, or other conditions resulting from misapplication of the fuel pumps and fuel pressure regulators described herein. However, it is our intent to provide the best possible products for our customer; products that perform properly and satisfy your expectations.

To preserve the warranty, these instructions must be read and followed thoroughly before and during installation.

PUMP REMOVAL:

WARNING! The fuel system may be under pressure. Do not remove any fuel lines until any pressure has been relieved. Refer to your vehicle service manual for procedures to relieve the fuel system.

1. Make sure the engine is cool. Disconnect the negative battery cable. Relieve any fuel pressure.
2. Disconnect the inlet and outlet fuel lines, as well as any electrical connections.
3. Remove the pump from the vehicle and place on a clean table or workbench.

WARNING! Carefully protect the open end of the fuel lines, so that no foreign particles can enter. Wrap the end of the fuel line with a clean lint-free cloth.

INLET REMOVAL:

1. Remove existing inlet from the pump and note the locations of any loose parts and seals.
2. Clean exposed pump surfaces before reassembly.
3. Prep the new inlet assembly for installation by installing new O-ring seal and screens per the included diagrams for your pump number below. Torque assembly screws to 20-25 in./lbs.

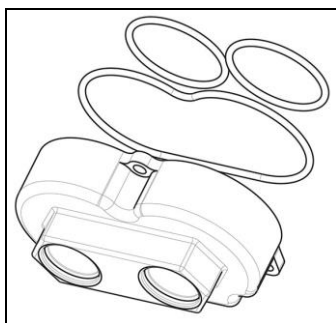

12-1200-2

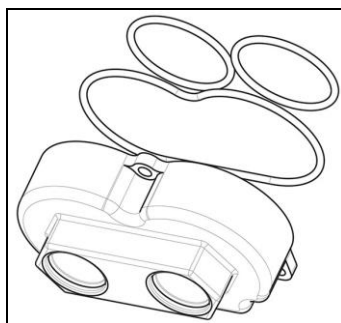

12-1600-2

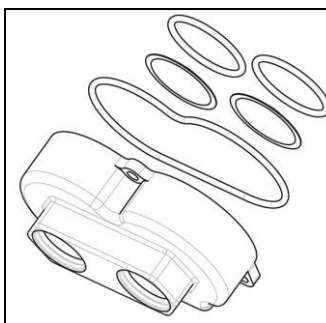

12-1800-2

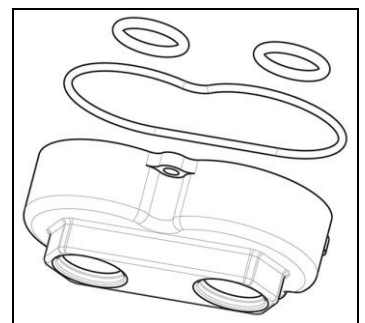

12-3000-2

REINSTALLATION:

1. Reinstall pump back into previous or new location.
2. Modify or install new plumbing connections to the pump.
3. Connect the electrical source for the pump and test cycle the pump to test for leaks at the pump and your fuel line connections.
4. If leaks are present, stop the pump and repair leaks before proceeding.