



THROTTLE BODY

P/N 502-9*

(1990 – 95) GM Truck 5.7L (V-8 Engine) 670 CFM

INSTALLATION & ADJUSTMENT INSTRUCTIONS

P/N 199R10332

*** Only for 1990 and up engines with “round” metri-pak TPS connector and 1994-1995 engines with throttle levers, not throttle cams.**

INTRODUCTION

Congratulations on your purchase of a Holley throttle body! Holley Performance Products has written this manual for the installation of the **Holley throttle body**. Please read all the **WARNINGS** and **NOTES**. They contain valuable information that can save you time and money. By using this number, you may obtain any information and/or parts assistance that you may require. Please have the part number on hand of the product you purchased when you call technical service.

WARNING! To preserve the warranty, instructions must be read and followed thoroughly and completely, before and during installation.

NOTE: Holley Performance Products cannot and will not be responsible for any alleged or actual engine or other damage or other conditions resulting from misapplication of the throttle body described.

NOTE: Prior to installation, please have your vehicle serviced if your “CHECK ENGINE” light is on.

NOTE: Prior to and after installing your new throttle body, manually operate the throttle lever to check for binding or other malfunction. Also, make a visual inspection of the throttle body, to look for bent levers, etc., or any other shipping damage.

REMOVAL

1. Remove the fuse marked “fuel pump” from the fuse block. Start the engine and allow it to run until the fuel supply remaining in the lines is consumed. When the engine stalls, engage the starter for three seconds to ensure all the pressure is relieved. **DO NOT** turn the key to the “RUN” position until the installation is complete.
2. Remove the air cleaner. Remove the air cleaner spacer from the top of the throttle body. This spacer will be used on the new throttle body.
3. Mark and remove the remaining vacuum lines from the throttle body. Remove all the electrical connections from the TBI.
4. Disconnect the throttle linkage and cruise control linkage from the throttle lever. Remove the transmission kickdown cable from the throttle lever (if equipped). Save all linkage clips. They will be used on the new Holley unit.

5. Remove the fuel lines from the TBI. It may be necessary to loosen the clamps located away from the TBI, in order to remove the lines from the fittings. Remove the fuel fittings from the TBI. These will be used with the Holley TBI.
6. Remove the TBI and the base gasket from the intake manifold. Place a clean shop towel in the manifold opening to prevent any foreign material from entering the intake. Clean the gasket surface of any remaining gasket material. Remove the towel after cleaning the flange surface.

INSTALLATION

1. Install fuel fittings on the Holley TBI. Fuel fittings should be torqued to 22 ft./lbs. Remove the 1/4-20 bolt. Install the stud (supplied) and 1/4-20 nut (supplied), torquing to 48 in./lbs. Use non-permanent Loctite on the air cleaner studs.

WARNING! Not properly tightening the air cleaner stud can lead to a fire hazard, which in turn can lead to property damage and/or personal injury.

2. Loosely install the TBI on the intake manifold using the new base gasket provided (install gasket with beveled throttle bore holes up). Be sure to install the air cleaner base gasket. Reconnect the fuel lines to the TBI using the new O-rings provided. Torque the TBI bolts first to 6-8 ft./lbs. and then torque the front TBI bolts to 10-12 ft./lbs. Do not reuse the TBI flange gasket. Always use a new gasket when reinstalling the TBI unit.

NOTE: The EGR bracket may have to be slightly bent for TPS clearance.

3. Reinstall the electrical connections, except for injectors, and vacuum lines to the TBI. Be sure that the vacuum lines are connected to the proper tubes and electrical connections are aligned and snapped together tightly.

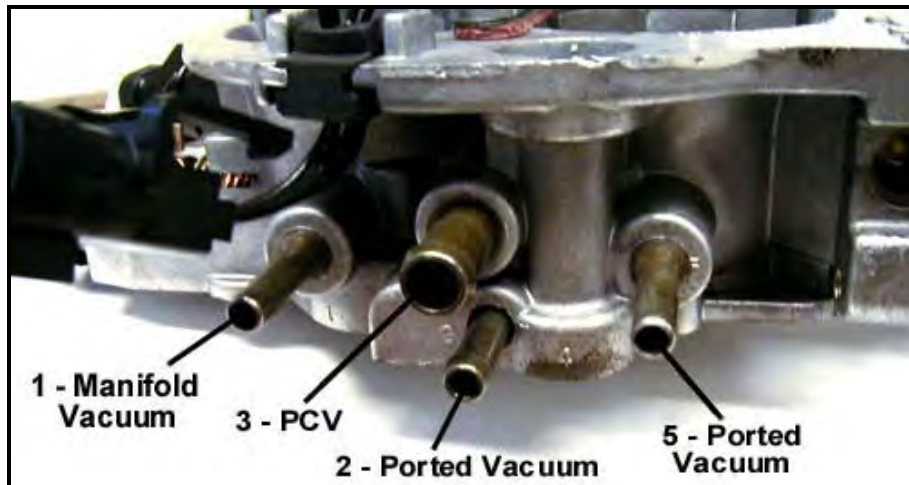

Figure 1

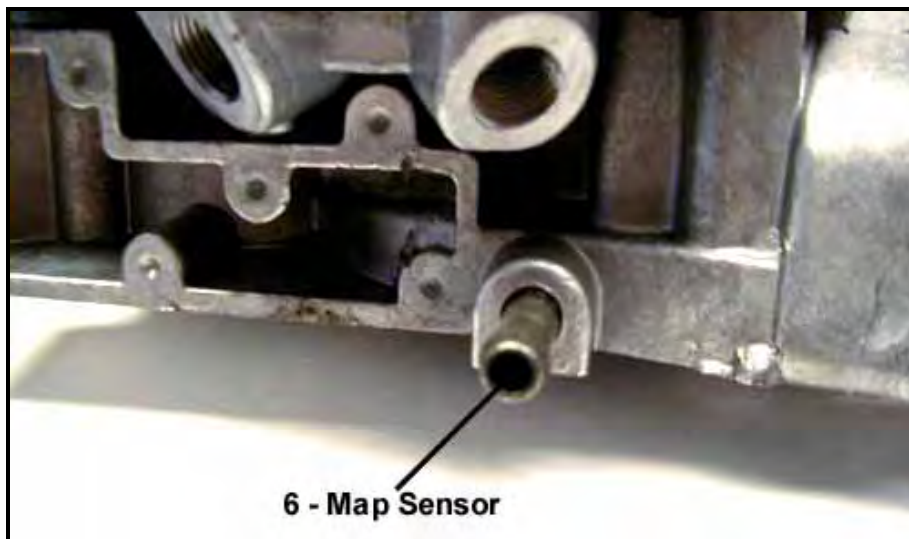

Figure 2

4. Cut the (4) injector wires about 12" from the factory injector connectors. Strip 1/4" of the insulation from the wires left on the vehicle. Connect these to the wires on the harness adapter assembly by using the butt connectors provided. The white wire needs to go to ONE of the pink, red, or white wires. MATCH the remaining wire colors with those on the vehicle. Push the connector with wires into the mating connector on the throttle body. See Figure 3.
5. Cut the (4) injector wires about 12" from the factory injector connectors. Strip 1/4" of the insulation from the wires left on the vehicle. Connect these to the wires on the harness adapter assembly by using the butt connectors provided. MATCH the wire colors with those on the vehicle. Push the connector with wires into the mating connector on the throttle body.
6. Reconnect the throttle linkage. For vehicles equipped with cruise control, install the included cruise control stud and locknut. Reconnect the linkage, and secure it with a clip. Reconnect the transmission kickdown cable (if equipped).

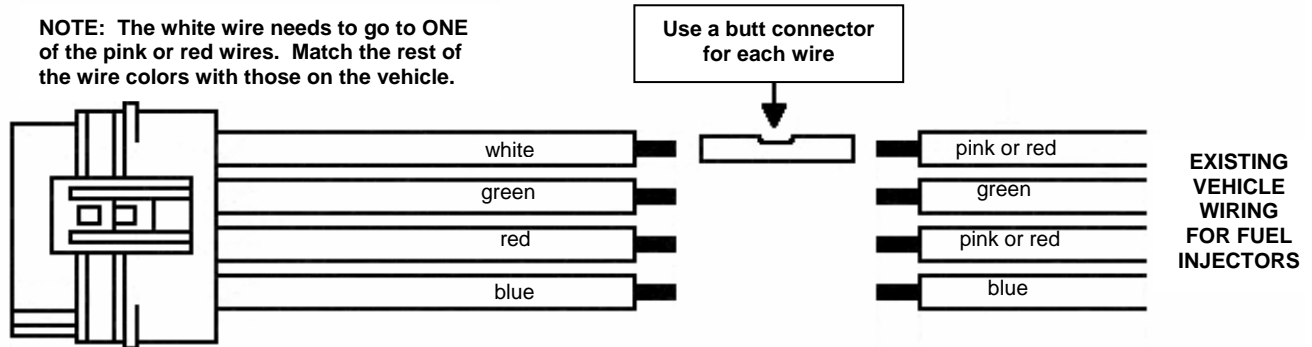

Figure 3

IMPORTANT: The TV cable must be readjusted in order for the automatic transmission to shift properly. Depress the metal lock tab on the adjuster and hold on. Pull the cable through the adjuster away from the TBI. Release the metal lock tab. Depress the accelerator pedal to wide-open throttle. The cable will self-adjust.

7. Reinstall the fuel pump fuse.
8. Cycle the ignition key from the "OFF" position to the "RUN" position several times, keeping the key in the "RUN" position for three seconds each time. Check the fuel connections for leaks.
9. Reinstall the air cleaner spacer and the air cleaner. Use the new gasket provided.

NOTE: The idle airflow, fuel pressure, and TPS for this unit are preset from the factory for stock engines. Modified engines may require that these are changed for optimum performance.

The following are the factory settings:

Fuel Pressure – 11 PSI

TPS – .65 Volts (Factory range for idle .5-1.0 volts; Wide-open-throttle – 4.5-5.0 volts)

10. Start the engine and let it run for several seconds. Shut off the engine and recheck for fuel leaks.

NOTE: The on-board computer has adaptive memory; therefore, performance characteristics may change after a few days of driving. Drive the vehicle to let it relearn.

NOTE: The on-board computer may have stored codes caused by the previous TBI malfunction. If it is necessary to clear these codes, disconnect the negative cable at the battery for 30 seconds. If the "CHECK ENGINE" light comes on, consult the vehicle's service manual and follow the diagnostic recommendations.

Troubleshooting:

Engine Idle Too Low

- Measure TPS signal wire voltage and verify that it is between .5 and 1.0 volts
- Open throttle plate idle adjustment screw until desired idle RPM is met, then recheck TPS voltage

Engine Running Rich or Lean

- Verify that fuel pressure is set at 11 PSI for stock engines