



HILBORN

FUEL INJECTION

Fuel Injection that delivers PERFORMANCE

with
RELIABILITY, POWER, INNOVATION, & DRIVABILITY



CONTACT US

Since its beginning in 1947, Hilborn Fuel Injection has grown to be a leader in the pioneering and implementation of high performance fuel injection, providing unmatched quality, service and technical expertise. Because of this, Hilborn injectors have been used successfully and set many records in all types of racing venues including oval track, drag, dry lakes, super modified, off-road, motorcycle, tractor pulling, hydroplanes, and Indy Lite series.

Thank you for taking time to browse our product catalog and we look forward to helping you with your fuel injection needs!



TABLE OF CONTENTS

FUEL INJECTORS FOR CHEVROLET 004

small block, V6, big block, LS, 409

FUEL INJECTORS FOR FORD 020

small block (windsor & cleveland), small block (302), SOHC, 390-427-428 FE, big block, flathead

FUEL INJECTORS FOR CHRYSLER 030

6.1L, late hemi, early hemi, 440 wedge

FUEL INJECTORS FOR DeSOTO 037

MODULAR FUEL INJECTORS 038

motorcycles and custom applications

FUEL INJECTORS FOR BUICK 040

nailhead

FUEL INJECTORS FOR BLOWN ENGINES 042

tall 4-port scoop injector, short 4-port scoop injector, 2- port 4-71 & 6-71 scoop injector, 4-hole hat injector, 2-hole Shot Gun injector, Enderle hat conversions to EFI

SINGLE THROAT FUEL INJECTORS 052

FUEL INJECTORS FOR TURBOCHARGED ENGINES 054

EFI KITS & COMPONENTS 056

Holley EFI, FAST XFI 2.0, Weldon fuel pumps & regulator, remote thermostat housing, Y-blocks & pressure gauge, synchrometer

THROTTLE BODY & MULTI PORT EFI 063

Holley Terminator EFI, Holley Avenger Systems, HP EFI

SYSTEM COMPONENTS 068

mechanical fuel pumps, pump drives, by-pass & cut off valves, metering valves, in-line fuel filter, shut-off valves, single gauge leak tester, nozzles, breather & plugs, ram tubes, ram tube adapters, air scoops, air filters, ram tube seals

INJECTOR MANIFOLD PARTS 080

hose lines, junction blocks, throttle linkage, butterflies, return springs, pinch clamp replacement, o-rings, seals, washers, gaskets, screws, caps



FUEL INJECTORS FOR SMALL BLOCK CHEVY



MEGA POWER SBC FUEL INJECTOR

Utilizing a 3-piece, curve throat design, the MEGA Power provides minimal flow disruption, allowing outstanding port speed for maximum cylinder fill. This injector will fit many heads; from the standard 23 degree, all the way to the newest raised runner shallow valve angle heads. As a three piece injector, it gives you the flexibility to fit numerous applications such as multiple deck heights or heavily modified heads.

Engine Application:

- specify model of heads and deck height
- specify up-nozzle or down-nozzle configuration

Fuel Delivery Options:

- Mechanical / Constant Flow

Standard Features:

- fully CNC ported magnesium castings or high quality heat treated aluminum castings
- precision machined in-house with standard CNC port openings (aluminum) or full CNC port openings (magnesium)
- valley plates available for standard, tall or custom deck heights
- throttle return springs installed
- includes by-pass valves, nozzles, breathers, fuel lines, barrel valve, and linkage
- clear anodize finish (aluminum) or powder coated (magnesium) for long lasting durability
- all units are factory flow-tested
- aluminum or steel ram tubes sold separately

Options:

- **HILBORN cross link kit**
- reducer style ram tubes
- removable throttle arm (*F104) or drive arm (*F105)
- powder coating
- port matching

PART NUMBERS

*327C8xxA.1 Aluminum Injector with 2-3/16", 2-7/16", or 2-1/2" bore

*327C8xxM.1P Magnesium Injector with 2-5/8" or 2-3/4" , 2-7/8" bore)

NOTE: "xx" used in the part number is a preliminary designator which will be replaced by a unique number corresponding to model number of heads.



RAW POWER “RACE-AND-WIN”

Racing is all about the power and Hilborn delivers all the RAW power you can use. Our RAW Power injector is the work-horse offering of the Hilborn line-up. This rugged and compact injector has won thousands of races in sprint cars, drag cars and all other kinds of racing venues. The RAW Power injector is packed with numerous standard features so you can take the checkered flag without busting your racing budget.

Fuel Delivery Options:

- Mechanical / Constant Flow

Engine Application:

- most SBC engines with 23 degree cylinder heads (excluding raised runner)
- 8 cylinder / 4 cylinder assembly options

Standard Features:

- high quality heat-treated clear anodized aluminum casting
- precision machined in-house
- removable base plate for easy port matching
- easily replaceable throats allow you to change bore size to meet engine power or rule requirements
- transition between throats and manifold base are CNC finished to ensure proper alignment
- throttle return springs installed
- primary and secondary bypass valves, metering valve, nozzles, & fuel lines
- cad-plated steel ram tubes
- all units are factory flow-tested at no additional charge

Options:

- longer nozzles for increased horsepower
- **HILBORN cross link kit**
- reducer style ram tubes
- removable throttle arm (*F104) or drive arm (*F105)
- powder coating
- port matching



*710A-3 1/2"-ASZ
Nozzle



Reducer Ram Tubes

PART NUMBERS

- *327C8A Sm Blk Chevy Fuel Injector (2-3/16")
- *327C8B Sm Blk Chevy Fuel Injector (2-7/16", 2-1/2")
- *327C8A/T Assembled Throats (2-3/16" bore)
- *327C8A/T Assembled Throats (2-7/16" or 2-1/2" bore)
- *327C8-1A/A Assembled Aluminum Base Plate

Ram Tube Options:

- F1043F Steel Ram Tube (2-3/16")
- F1047F Steel Ram Tube (2-7/16")
- F1048A Aluminum Ram Tube (2-1/2")



CHRIS ALLEN, 2011 TSRS RACESAVER CHAMPION (#1) LINES UP WITH MIKE HAGGENBOTTOM, 2012 TSRS RACESAVER CHAMPION (#24) AT NEW EGYPT SPEEDWAY. BOTH RACESAVER CHAMPIONS RELIED ON HILBORN POWER FOR THEIR WINNING SEASON.
PHOTO BY ED MALIK PHOTOGRAPHY

FUEL INJECTORS FOR SMALL BLOCK CHEVY

HILBORN CROSS LINK KIT

NEW Hilborn's heavy duty cross link kit was designed to take on the stresses that only a race car can produce.

A rigid, centerless ground, hard chromed 3/8" shaft and heavy duty rod ends are anchored directly to the injector body, providing strength and reliability. Attached to the shaft are removable throttle arms with twin bolts for extra holding power and fully adjustable hex links for fine tuning. It's tough, rugged, and there to finish the race with you.

Upgrade your injector today with Hilborn's heavy duty cross link kit!

PART NUMBERS

C L100 Fits Mega Power and RAW Power Fuel Injectors for SB Chevy



V6 CHEVY FUEL INJECTOR

It's been said that great things come in small packages, and the Chevy 90 degree V-6 is one of them.

Based on the tried and true first generation SBC, the smaller V-6 has impressed many with its performance potential while catching the eye of those looking for a smaller engine package. But just because it's small doesn't mean it needs to be low on power... and one of the best ways to pump up your V-6 is with a Hilborn EFI Kit.

Fuel Delivery Options:

- **EFI**

Engine Application:

- 200, 229, 4.3L 90° engines, standard deck height, 23° heads

Standard Features:

- high quality heat-treated aluminum casting
- cad-plated steel ram tubes
- fully assembled with shafts, butterflies, linkage
- EFI model includes split throttle shafts, fuel rails, mounted TPS with connector and vacuum kit.

Options:

- polished castings
- powder coating
- chrome ram tubes
- port matching
- complete hand porting



PART NUMBERS

*EFI229C6A/EL V6 Chevy EFI Kit (2-3/16")

Ram Tube:

Requires (4) F1043F D-bell Steel Ram Tubes and (2) F943F full bell Steel Ram Tubes





HUGH JARVIS' SCARAB
PHOTOS COURTESY **SCARAB MOTORSPORTS**



SB CHEVY EFI FUEL INJECTOR

Known the world over as the most prolific engine ever produced, the Small Block Chevy has been used in countless racing venues with resounding results. Racers have set record after record with these little engines and the fastest have counted on Hilborn injection to provide the power to do so. Now, with a Hilborn EFI Kit, you can have the same power the racers rely on, along with all the drivability EFI has to offer. From 290hp crate engines to big cubic inch stroker motors....we have a Fuel Injector to fit your combination.

Fuel Delivery Options:

- **EFI**

Engine Application:

- most SBC engines with 23 degree cylinder heads (excluding raised runner)

Standard Features:

- high quality heat-treated aluminum casting
- cad-plated steel ram tubes
- fully assembled with shafts, butterflies, linkage
- includes split throttle shaft, fuel rails, mounted TPS with connector and vacuum kit

Options:

- polished castings
- chrome ram tubes
- powder coating
- port matching
- complete hand porting

PART NUMBERS

*EFI327C8A Sm Blk Chevy EFI Kit (2-3/16")

*EFI327C8B Sm Blk Chevy EFI Kit (2-7/16", 2-1/2")

Ram Tube Options:

F1043F Steel Ram Tube (2-3/16")

F1047F Steel Ram Tube (2-7/16")

F1048A Aluminum Ram Tube (2-1/2")

Ram Tube/Air Cleaner Combo Unit



FUEL INJECTORS FOR SMALL BLOCK CHEVY

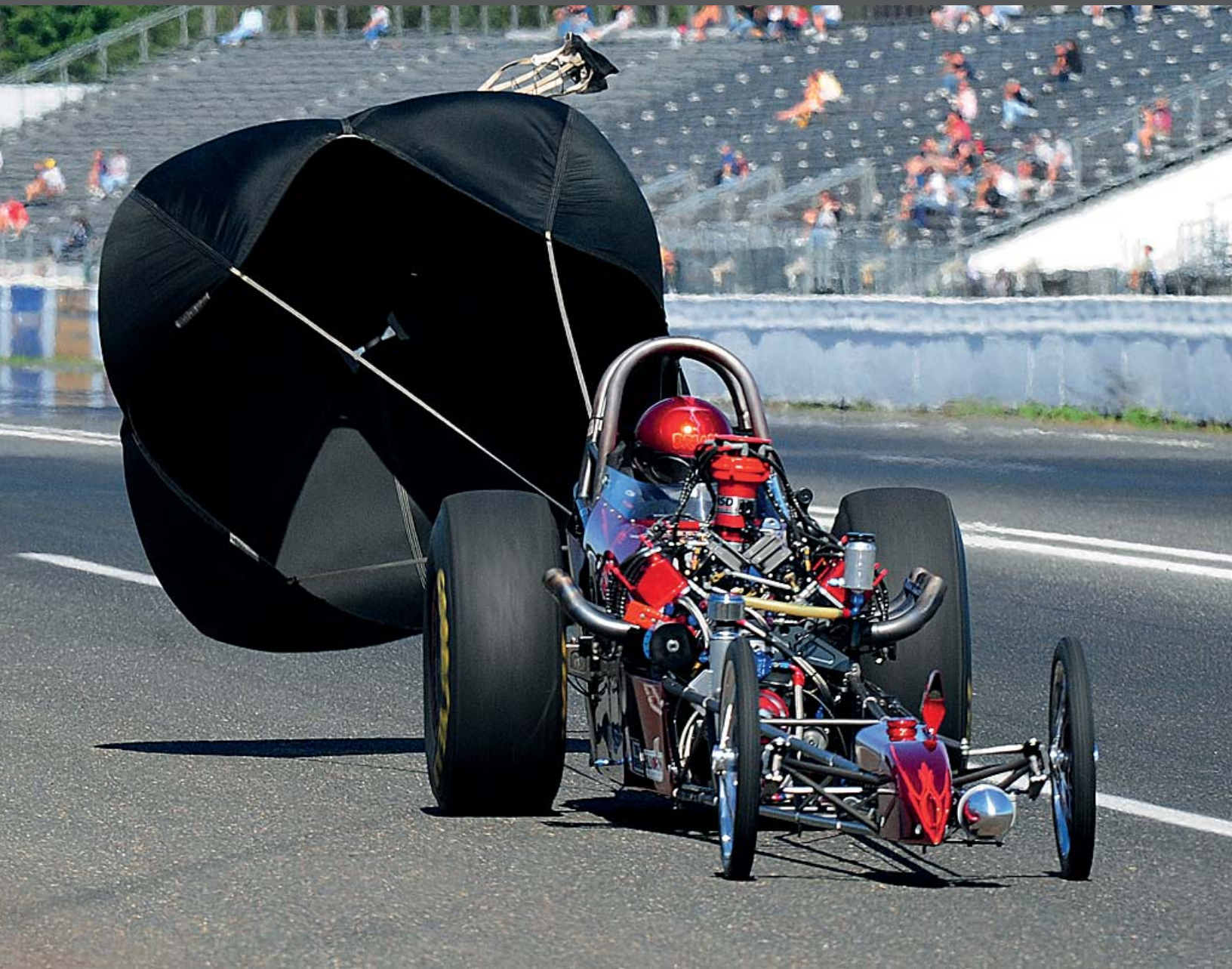

BRIAN DARCY'S COMP ELIMINATOR A/ND
PHOTO BY **TODD DZIADOSZ**

THE ROTARY FUEL INJECTOR

This innovative fuel injector features an internal rotating cylinder instead of traditional throttle shafts and butterflies. The rotary design produces unrestricted air flow with maximum torque and horsepower throughout the full range of throttle openings. The result is outstanding acceleration and instant throttle response.

Changing heads? With a Rotary Fuel Injector, housings can be reused and reassembled so there is no need to purchase a whole new injector. Just give us the make and model number of your new heads and we can supply a new set of adapter plates to match. You'll have a complete unit at a fraction of the cost.

Fuel Delivery Options:

- Mechanical / Constant Flow

Engine Application:

- 4 or 8 cylinder SBC styled engines with a range of deck heights using exotic-type, raised port, shallow valve angle cylinder heads.
- 4 or 8 cylinder SBC 23 degree cylinder heads (excluding raised runner).

Standard Features:

- throttle return springs installed
- pull style throttle linkage with 3 stops
- idle adjustment screws
- sealed nozzles, breathers, lines, and barrel valve
- magnesium air inlets included
- all units are factory flow-tested

Specify:

- model of head and block for correct port dimensions
- up-nozzle or down-nozzle set-up

Additional Items:

- by-pass valves sold separately
- K & N or R2C air box filter
- 1" and 3" removable extension spacers. The modular design of the Air Inlets allows you to add one or more spacers to extend the length, so you can tailor the torque according to the type of racing or track conditions.



Rotary-Drag, up-nozzle set up



Rotary-Sprint, down-nozzle set up

PART NUMBERS

- *R360C8-Drag Rotary Fuel Injector
- *R360C8-Sprint Rotary Fuel Injector
- *R360C8-23 Degree Rotary Fuel Injector
- *R360C8-Midget Rotary Fuel Injector



BB CHEVY FUEL INJECTOR

Chevy enthusiasts all over the world have turned to the Big Block Chevy for big power and tire shredding torque. From GM crate engines to large cubic inch aftermarket engines, we have the perfect induction system to maximize the performance of your Big Block.

Fuel Delivery Options:

- Mechanical / Constant Flow
- **EFI**

Engine Application:

- BBC engines with any deck height and 23 degree heads. Rectangular port can be adapted to oval port with no power loss. Specify standard or tall deck when ordering.

Standard Features:

- high quality heat-treated aluminum casting
- cad-plated steel or aluminum, raw finish ram tubes
- fully assembled with shafts, butterflies, linkage
- MECHANICAL model includes metering valve, nozzles, fuel lines, and primary/secondary bypass valves.
- EFI model includes split throttle shafts, fuel rails, mounted TPS with connector and vacuum kit.

Options:

- polished castings
- powder coating
- chrome ram tubes
- port matching
- complete hand porting

PART NUMBERS

*396-C-8L Big Blk Chevy Fuel Injector (2-7/16")

*EFI396C8L/EL Big Blk Chevy EFI Kit (2-7/16")

*396-C-8M Big Blk Chevy Fuel Injector

*EFI396C8M/EL Big Blk Chevy EFI Kit

Bore Sizes:

2-7/16", 2-1/2", 2-5/8", 2-3/4", 2-7/8", or 3"

Ram Tube Options:

F1047F Steel Ram Tube (2-7/16")

F1047A Aluminum Ram Tube (2-7/16")

F1055A Aluminum Ram Tube (3")

Ram Tube/Air Cleaner Combo Unit



3" bore



3" bore

2-7/16" bore

ED HOFFMAN'S "BARELY LEGAL" GASSER
PHOTO BY GENE ANGELINO



THE LS CHEVY FUEL INJECTOR

LS Chevy engines were designed by GM engineers who are racers at heart. Using a clean sheet of paper, they employed racing components and technology such as shallow valve angle cylinder heads, thin piston rings, titanium connecting rods and even dry sump oiling systems. These components conspire to make tremendous power while retaining street manners and fuel economy. Because of this, the LS engines are now poised to be the greatest small block engines GM has ever built.

Is your LS engine screaming for a Hilborn? This injector is available in 4 bore sizes allowing us to cater to your specific application. For Gen III engine applications, a machined aluminum finned lifter valley cover is also available to replace the factory knock sensors.

Fuel Delivery Options:

- Mechanical / Constant Flow
- **EFI**

Engine Application:

- LS1, L92, LS7 heads

Standard Features:

- high quality heat-treated aluminum casting
- cad-plated steel or aluminum, raw finish ram tubes
- fully assembled with shafts, butterflies, linkage
- MECHANICAL model includes metering valve, nozzles, fuel lines, and primary/secondary bypass valves.
- EFI model includes split throttle shafts, fuel rails, mounted TPS with connector and vacuum kit.

Options:

- polished castings
- powder coating
- chrome ram tubes
- port matching
- complete hand porting

PART NUMBERS

*351F8LS LS Chevy Fuel Injector

*EFI351F8LS/EL LS Chevy EFI Kit

Bore Sizes:

2-3/16", 2-7/16", 2-1/2", or 2-5/8"

Ram Tube Options:

F943 Steel Ram Tube (2-3/16")

F947F Steel Ram Tube (2-7/16")

F947A Aluminum Ram Tube (2-7/16")

F948A Aluminum Ram Tube (2-1/2")

Ram Tube/Air Cleaner Combo Unit



MAURIE & LYNNE HOOVER'S '67 CHEVY C-10 PICKUP "SHAMELESS"



409 CHEVY FUEL INJECTOR

The 348-409 engines were the beginning of true high performance engines for Chevrolet. At its peak, the 409 made the magical one horsepower per cubic inch, and was not only very popular with racers, it was feared by the competition. Now the 409 is back and it's as hot as ever! A Hilborn injector will breathe new life into your 409 producing awesome torque and power along with race inspired engine acceleration. Fits stock or aftermarket aluminum heads. Shown here with optional powder coated casting and chromed tubes.

Fuel Delivery Options:

- Mechanical / Constant Flow
- **EFI**

Standard Features:

- high quality heat-treated aluminum casting
- cad-plated steel or aluminum, raw finish ram tubes
- fully assembled with shafts, butterflies, linkage
- MECHANICAL model includes metering valve, nozzles, fuel lines, and primary/secondary bypass valves.
- EFI model includes split throttle shafts, fuel rails, mounted TPS with connector and vacuum kit.

Options:

- polished castings
- powder coating
- chrome ram tubes
- port matching
- complete hand porting



PART NUMBERS

*396-C-8T 409 Chevy Fuel Injector

*EFI396C8T/EL 409 Chevy EFI Kit

Bore Sizes:

2-7/16" or 2-1/2"

Ram Tube Options:

F1047F Steel Ram Tube (2-7/16")

F1047A Aluminum Ram Tube (2-7/16")

F1048A Aluminum Ram Tube (2-1/2")

Ram Tube/Air Cleaner Combo Unit



'62 IMPALA BUBBLE TOP

BUILDER: DOOLEY & SONS

PHOTO STEPHEN KIM PHOTOGRAPHY



FUEL INJECTORS FOR FORD



DARYL WOLFSWINKEL'S 34 FORD - 2011 AMBR WINNER
BUILDER: [SQUEEG'S KUSTOMS](#)

SB FORD FUEL INJECTOR (WINDSOR/CLEVELAND)

With the ever increasing availability of high performance parts, Windsor based engines now propel the fastest turbo, nitrous and NASCAR racing engines. With a Hilborn injector you can now have your own bullet! The 3 piece manifold design allows us to machine the port for your application, giving us the flexibility to fit numerous versions of the Windsor, Cleveland and Boss 302 engines.

Fuel Delivery Options:

- Mechanical / Constant Flow
- **EFI**

Engine Application:

- SBF based engines with any combination of Windsor or Cleveland heads and 9.5 or 9.2 inch deck heights, including factory iron, aftermarket aluminum, 2V, 4V, Yates and CHI heads.
- with our 3 piece design we can also accommodate the 351M and 400 applications with any variation of cylinder head and factory 10.29 inch deck height.
- for high performance 302, or for all 302 Boss applications: Due to reduced clearance between the cylinder heads, a distributor offset, relocated distributor, or coil over plug ignition will be required.
- 4 cylinder model also available

Standard Features:

- high quality heat-treated aluminum casting
- cad-plated steel or aluminum, raw finish ram tubes
- fully assembled with shafts, butterflies, linkage
- MECHANICAL model includes metering valve, nozzles, fuel lines, and primary/secondary bypass valves.
- EFI model includes split throttle shaft, fuel rails, mounted TPS with connector and vacuum kit

Options:

- polished castings
- chrome ram tubes
- powder coating
- port matching
- complete hand porting

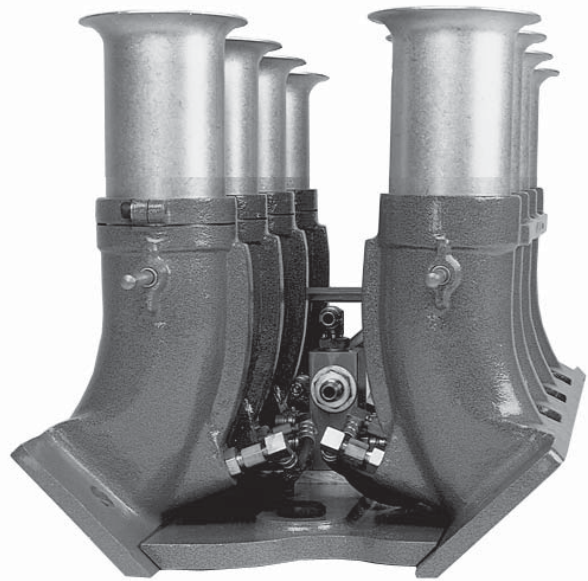

PART NUMBERS

*351F8 SB Ford Fuel Injector

*EFI351F8/AE SB Ford EFI Kit

Bore Sizes:

2-3/16", 2-7/16", 2-1/2", or 2-5/8"

Ram Tube Options:

F943F Steel Ram Tube (2-3/16")

F947F Steel Ram Tube (2-7/16")

F948A Aluminum Ram Tube (2-1/2")

F950A Aluminum Ram Tube (2-5/8")

Ram Tube/Air Cleaner Combo Unit



SB FORD FUEL INJECTOR (302)

The 302 Ford has a long lineage....used in everything from Trans-Am racing to one's own first hotrod. Ford hasn't forgotten their roots, and neither have we. Hilborn's 302 injector takes us back to an era when GT road racing was king and injection was a way of life.

Fuel Delivery Options:

- Mechanical / Constant Flow
- **EFI**

Engine Application:

- SBF engines based on the 8.2 inch 302 deck height

Standard Features:

- high quality heat-treated aluminum casting
- cad-plated steel ram tubes
- fully assembled with shafts, butterflies, linkage
- MECHANICAL model includes metering valve, nozzles, fuel lines, and primary/secondary bypass valves.
- EFI model includes split throttle shaft, fuel rails, mounted TPS with connector and vacuum kit

Options:

- polished castings
- chrome ram tubes
- powder coating
- port matching
- complete hand porting

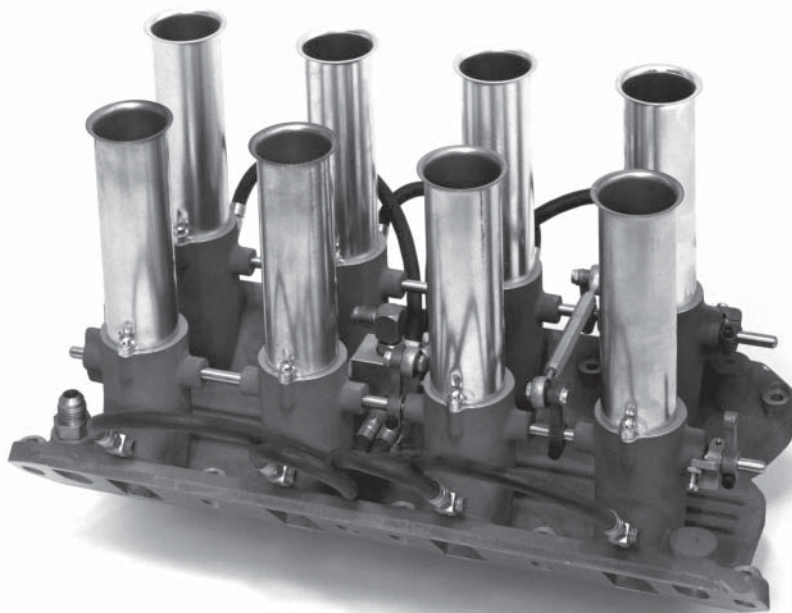

PART NUMBERS

*260-F-8B SB Ford /302 Fuel Injector (1-13/16")

*EFI260F8B/EL SB Ford / 302 EFI Kit (1-13/16")

Ram Tube Options:

F143 Steel Ram Tube (1-13/16")

Ram Tube Adapters with slip-in tubes available



TOM GLORY'S '32 FORD ROADSTER - 2012 WINNER OF GOODGUYS TANK'S HOT ROD OF THE YEAR AWARD
BUILDER: Roy BRIZIO STREET RODS
PHOTO BY JOHN JACKSON

FUEL INJECTORS FOR FORD

JACK HAZELGREN'S '64 FAIRLANE WITH
HILBORN INJECTED SOHC



FORD SOHC FUEL INJECTOR

The 427 SOHC or "Cammer" was originally designed to take on the new 426 Hemi used in NASCAR. Using a 427 FE block as its foundation, the Cammer's secret weapon was monstrous cylinder heads with a single cam on each one, resulting in monstrous power....so much power that NASCAR outlawed it. Big power is what the Cammer is all about and nothing says power like a Hilborn injector.

Fuel Delivery Options:

- Mechanical / Constant Flow
- **EFI**

Standard Features:

- high quality heat-treated aluminum casting
- cad-plated steel ram tubes
- fully assembled with shafts, butterflies, linkage
- MECHANICAL model includes metering valve, nozzles, fuel lines, and primary/secondary bypass valves.
- EFI model includes split throttle shaft, fuel rails, mounted TPS with connector and vacuum kit

Options:

- polished castings
- chrome ram tubes
- powder coating
- port matching
- complete hand porting

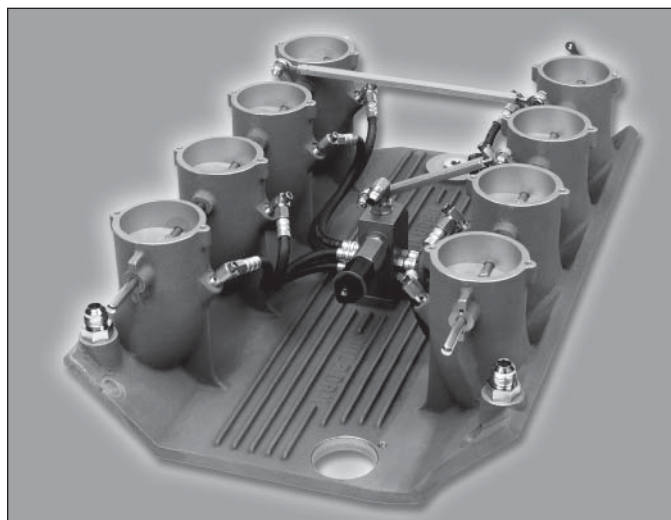

PART NUMBERS

*427F8SO Ford SOHC Fuel Injector (2-7/16")

*EFI427F8SO/EL Ford SOHC EFI Kit (2-7/16")

Ram Tube Options:

F147 Steel Ram Tube (2-7/16")

Ram Tube Adapters with slip-in tubes available



FE FORD FUEL INJECTOR

Recently embraced as a marquee engine for its uniqueness and power production, the potent FE Ford can also have the most unique and powerful induction system available, a Hilborn injector. Just like many years ago when an FE in your car meant you were serious about power, a Hilborn injector can take it to the next level with awesome throttle response, low end torque, and top end power to burn. Ford FE injectors are based on a Blue Thunder Weber style intake. Hilborn can supply either the straight or angle cut design.

Fuel Delivery Options:

- Mechanical / Constant Flow
- **EFI**

Engine Application:

- FE big block 390, 427 lowrise and medium rise, 428, and 428 Cobra Jet.

Standard Features:

- high quality heat-treated aluminum casting
- cad-plated steel ram tubes
- fully assembled with shafts, butterflies, linkage
- MECHANICAL model includes metering valve, nozzles, fuel lines, and primary/secondary bypass valves.
- EFI model includes split throttle shaft, fuel rails, mounted TPS with connector and vacuum kit

Options:

- polished castings
- chrome ram tubes
- powder coating
- port matching
- complete hand porting

PART NUMBERS

*427F8B FE Ford Fuel Injector (2-3/16" or 2-3/8")
*EFI427F8B/EL FE Ford EFI Kit (2-3/16" OR 2-3/8")
BT427-A Blue Thunder Manifold, angled cut
BT427-S Blue Thunder Manifold, straight cut

Ram Tube Options:

F843 Steel Ram Tube (2-3/16")
F847 Steel Ram Tube (2-7/16")
Ram Tube Adapters with slip-in tubes available



BIG BLOCK FORD FUEL INJECTOR

The 429/460 Ford big block with its large canted valve cylinder heads have made this engine a mainstay for many high performance builds over the years. Big cubic inches supply tire shredding torque and can easily turn any project into a scary handful. But for those looking for the thrill of a lifetime, Hilborn has got the perfect induction system for the 429/460. A Hilborn can not only up the thrill factor, but also deliver the drivability your project deserves.

Fuel Delivery Options:

- Mechanical / Constant Flow
- **EFI**

Engine Application:

- 429 or 460 based BB Ford engines, regardless of displacement.

Standard Features:

- high quality heat-treated aluminum casting
- cad-plated steel ram tubes
- fully assembled with shafts, butterflies, linkage
- MECHANICAL model includes metering valve, nozzles, fuel lines, and primary/secondary bypass valves.
- EFI model includes split throttle shaft, fuel rails, mounted TPS with connector and vacuum kit

Options:

- polished castings
- chrome ram tubes
- powder coating
- port matching
- complete hand porting



PART NUMBER

- *460F8 Big Block Ford Fuel Injector (2-3/16" or 2-3/8")
- *EFI460F8/EL Big Block Ford EFI Kit (2-3/16" OR 2-3/8")

BT429-A Blue Thunder Manifold, angled cut
BT429-S Blue Thunder Manifold, straight cut

Ram Tube Options:

- F843 Steel Ram Tube (2-3/16")
- F847 Steel Ram Tube (2-7/16")
- Ram Tube Adapters with slip-in tubes available



FLATHEAD JACK'S TWIN FLATHEAD DRAGSTER
AS SEEN IN **ROD & CUSTOM**



FORD FLATHEAD FUEL INJECTOR

This is the one that started it all! In 1947 Stuart Hilborn built his very first injector for the flat-head, and with it, his streamliner became the first car to go 150mph at El Mirage...a true milestone in hot rod history.

Fuel Delivery Options:

- Mechanical / Constant Flow
- **EFI**

Standard Features:

- high quality heat-treated aluminum casting
- cad-plated steel ram tubes
- fully assembled with shafts, butterflies, linkage
- MECHANICAL model includes metering valve, nozzles, fuel lines, and primary bypass valve.
- EFI model includes split throttle shafts, fuel rails, mounted TPS with connector and vacuum kit.

Options:

- ram tube adapters for slip-in tubes
- polished castings
- powder coating
- chrome ram tubes
- port matching
- complete hand porting

PART NUMBERS

*239-F-8A (1-11/16" bore) Fuel Injector

*EFI-239F8A/EL (1-11/16" bore) EFI KIT

Ram Tube:

F142 Steel Ram Tube (1-11/16")

Ram Tube Adapters with slip-in tubes available



FUEL INJECTORS FOR CHRYSLER



CHIP FOOSE DESIGNED “HEMISFEAR”
AS SEEN IN **HOT ROD**

6.1 HEMI FUEL INJECTOR

Born out of the shadows of the earlier Chrysler Hemi, the 6.1L holds true to its heritage as the next great muscle car engine, and a perfect candidate for a swap into your rod. We can't leave well enough alone either so, taking a cue from Chrysler, we developed a Hilborn injector for the 6.1L. Testing once again showed that a Hemi and a Hilborn is a perfect match, with smooth power and torque that climbed above the factory combination. Let the ram tubes fill the engine bay and you'll have a combination that can't be beat!

Fuel Delivery Options:

- **EFI**

Standard Features:

- high quality heat-treated aluminum casting
- cad-plated steel ram tubes
- fully assembled with shafts, butterflies, linkage
- EFI model includes split throttle shaft, fuel rails, mounted TPS with connector and vacuum kit

Options:

- polished castings
- chrome ram tubes
- powder coating
- port matching
- complete hand porting



PART NUMBERS

*EFI6.1CH8/EL 6.1 Chrysler EFI Kit (2-3/16" bore)

Ram Tube Options:

F943 Steel Ram Tube (2-3/16")



LATE HEMI FUEL INJECTOR

The 426 Chrysler Hemi, otherwise known as the "Elephant", is arguably the most recognizable high performance engine of all time. It has powered some of the most recognizable and fastest race cars of all time such as the Summers Brothers Goldenrod, a 400+ mph Bonneville streamliner, as well as all NHRA top fuel dragsters.

Our NEWEST model for the Hemi is based off of a huge 2-7/8 butterfly casting that is redesigned to accept butterflies as small as 2-7/16. So, if you're running a stock 426 engine, or an 1100 hp 604 cid monster, we can choose the best size for your combination. Available for 16 bolt heads only.

Fuel Delivery Options:

- Mechanical / Constant Flow
- **EFI**

Engine Application:

- all Chrysler, Plymouth, Dodge or aftermarket 426 hemi based engines.

Standard Features:

- high quality heat-treated aluminum casting
- aluminum ram tubes 2-7/8" ID
- fully assembled with shafts, butterflies, linkage
- MECHANICAL model includes metering valve, nozzles, fuel lines, and primary/secondary bypass valves.
- EFI model includes split throttle shaft, fuel rails, mounted TPS with connector and vacuum kit.

Options:

- polished castings
- polished ram tubes
- powder coating
- port matching
- complete hand porting



PART NUMBERS

*426-CH-8K Late Chrysler Fuel Injector

*EFI426CH8K/EL Late Chrysler EFI Kit

Bore Size:

2-7/16" 2-5/8", 2-7/8"

Ram Tube Options:

F954A Aluminum Ram Tube (2-7/8" ID)

**KRISTI & JERRY KELLER'S '64 DODGE
2-DR POST CAR, PRO STREET**



EARLY HEMI FUEL INJECTOR

The quintessential hot rod engine of all time! No other engine comes close to the Chrysler 331/392 hemi in racing heritage.

Fuel Delivery Options:

- Mechanical / Constant Flow
- **EFI**

Engine Application:

- 331, 354, 392 early Chrysler Hemi 1951-1958

Standard Features:

- high quality heat-treated aluminum casting
- cad-plated steel ram tubes
- fully assembled with shafts, butterflies, linkage
- MECHANICAL model includes metering valve, nozzles, fuel lines, and primary/secondary bypass valves.
- EFI model includes split throttle shaft, fuel rails, mounted TPS with connector and vacuum kit

Options:

- polished castings
- chrome ram tubes
- powder coating
- port matching
- complete hand porting



PART NUMBERS

*331-CH-8G Early Chrysler Fuel Injector (2-7/16 bore)

*EFI331CH8H/EL Early Chrysler EFI Kit (2-3/16" bore)

Ram Tube Options:

F843 Steel Ram Tube (2-3/16")

F847 Steel Ram Tube (2-7/16")

Ram Tube Adapters with slip-in tubes available

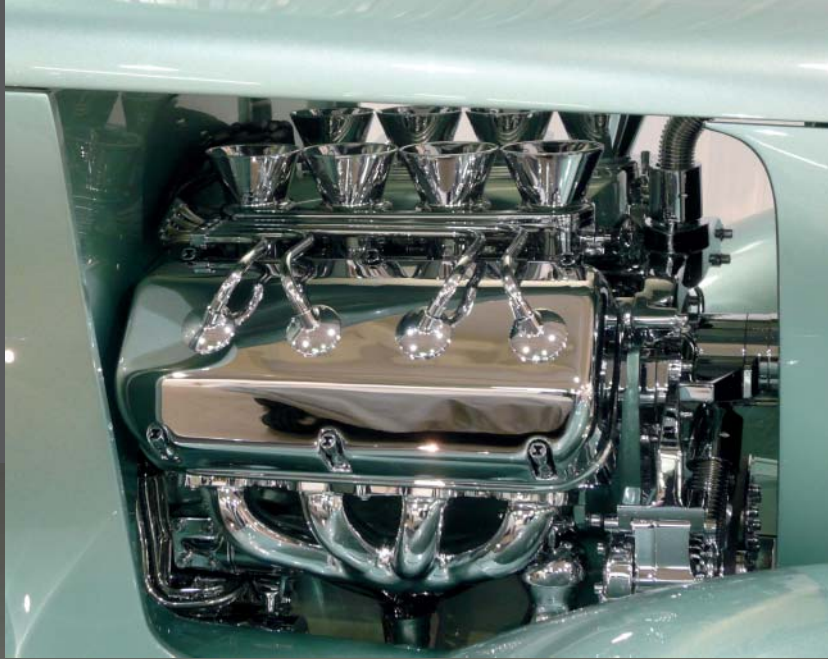

RICH & PAIGE UDELL'S '32 FORD "TIMELESS"
PHOTO **TOM FEDRIGO PHOTOGRAPHY**

440 WEDGE FUEL INJECTOR

Redesigned to incorporate our current curved-throat design for increased engine efficiency and performance, this injector is offered in a wedge or the max wedge port size.

Fuel Delivery Options:

- Mechanical / Constant Flow
- **EFI**

Engine Application:

- 440 Chrysler based engines with Wedge port dimensions of 1-1/4" x 2-3/8"

Standard Features:

- high quality heat-treated aluminum casting
- cad-plated steel ram tubes
- fully assembled with shafts, butterflies, linkage
- MECHANICAL model includes metering valve, nozzles, fuel lines, and primary/secondary bypass valves.
- EFI model includes split throttle shaft, fuel rails, mounted TPS with connector and vacuum kit

Options:

- polished castings
- chrome ram tubes
- powder coating
- port matching
- complete hand porting

PART NUMBERS

- *396C8R Chrysler Wedge Fuel Injector
- *396C8S Chrysler Max Wedge Fuel Injector
- *EFI396C8R Chrysler Wedge EFI Kit
- *EFI396C8S Chrysler Max Wedge EFI Kit

Bore Sizes:

2-7/16" or 2-1/2"

Ram Tube Options:

F1047F Steel Ram Tube (2-7/16")

F1048A Aluminum Ram Tube (2-1/2")

Ram Tube Adapters with slip-in tubes available

Ram Tube/Air Cleaner Combo Unit



DESOTO FUEL INJECTOR

With its roots clearly defined in the early days of drag and Bonneville racing, the DeSoto Hemi powered many famous cars....none more famous than the Adams and Enriquez Jr. Fueler. With a 305cid DeSoto, their Hilborn injected dragster was the first naturally aspirated car to run over 200 mph in the quarter, tripping the lights at 202.24 mph. Now it's your chance to make history with a Hilborn injector or EFI Kit for your DeSoto....offering legendary power and smooth drivability.

Fuel Delivery Options:

- Mechanical / Constant Flow
- **EFI**

Engine Application:

- 1952-1957 late De Soto

Standard Features:

- high quality heat-treated aluminum casting
- cad-plated steel ram tubes
- fully assembled with shafts, butterflies, linkage
- MECHANICAL model includes metering valve, nozzles, fuel lines, and primary/secondary bypass valves.
- EFI model includes split throttle shaft, fuel rails, mounted TPS with connector and vacuum kit

Options:

- polished castings
- chrome ram tubes
- powder coating
- port matching
- complete hand porting

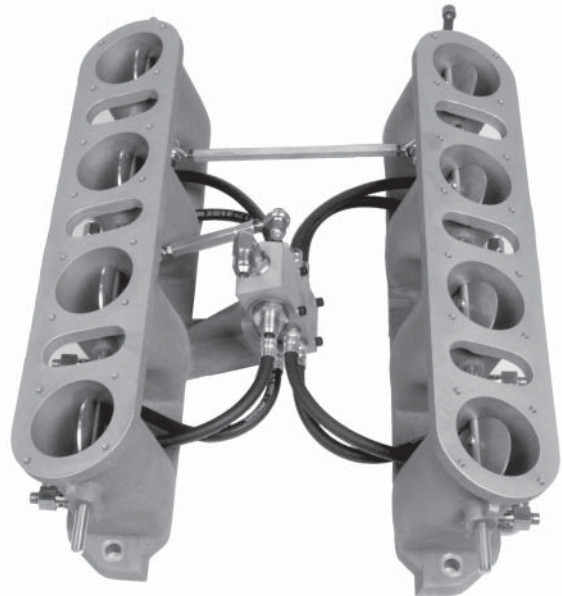

PART NUMBERS

*276D8A DeSoto Fuel Injector (2-3/16")

*EFI4276D8A/EL DeSoto EFI Kit (2-3/16")

Ram Tube Options:

F843 Steel Ram Tube (2-3/16")

Ram Tube Adapters with slip-in tubes available



THE MODULAR FUEL INJECTOR

Want a Hilborn but have a unique or custom application? Our Modular injector is the perfect choice with individual adjustable throats that can be configured to fit any port spacing.

We've built Modular Injectors for applications such as in-line six cylinder engines, custom heads and V-12 applications. Because of its flexibility, the Modular can be made with your specific port spacing and is available with different bore and nipple sizes.

For motorcycles and motorcycle engine equipped cars, our 4-Throat Modular Injector can be assembled to fit the center-to-center port spacing for various engines including Honda, Kawasaki, Suzuki, and Yamaha. It includes interchangeable nipples available in various sizes. For Harley Davidson engines, please see our Single Throat Mechanical Fuel Injectors.

Fuel Delivery Options:

- Mechanical / Constant Flow
- **EFI**

Standard Features:

- high quality heat-treated aluminum casting
- cad-plated steel ram tubes
- fully assembled with shafts, butterflies, linkage
- MECHANICAL model includes metering valve, nozzles, fuel lines, and primary/secondary bypass valves.
- EFI model includes split throttle shaft, fuel rail, mounted TPS with connector. Vacuum reference ports are not available and will need to be added by you.

Options:

- polished castings
- chrome ram tubes
- powder coating
- port matching
- complete hand porting



PART NUMBERS

*75M4 4-Throat Modular Injector

*EFI75M4/EL 4-Throat Modular EFI Kit

Bore Sizes:

1-11/16" (42.86mm)

1-13/16" (42.03mm)

1-15/16" (49.21mm)

Ram Tube Options:

F935F Steel Ram Tube (1-11/16")

F936F Steel Ram Tube (1-13/16")

F940F Steel Ram Tube (1-15/16")

'32 ROADSTER PICKUP
BUILDER: HOLLYWOOD HOT RODS



FUEL INJECTORS FOR BUICK

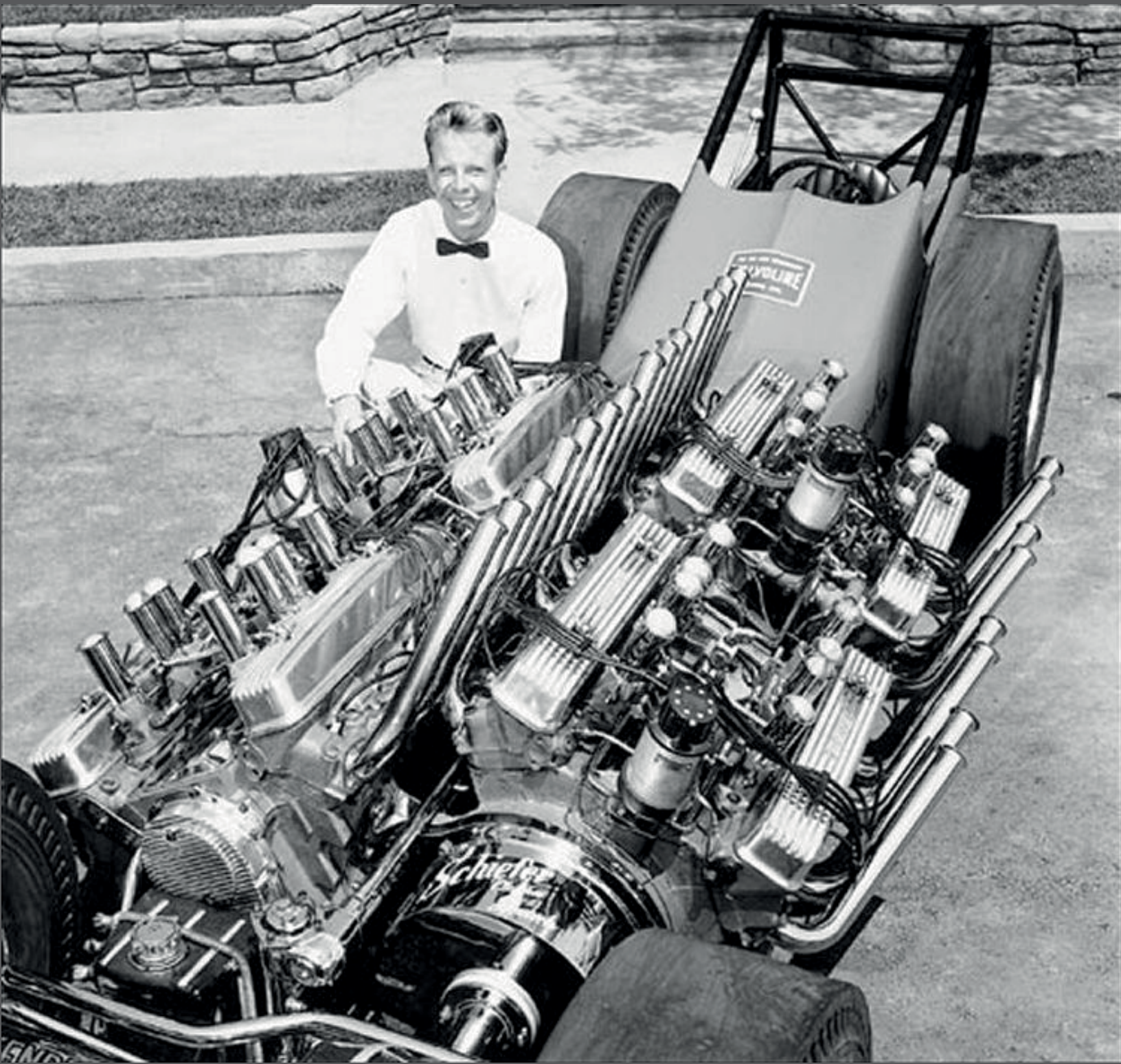

TOMMY IVO'S BUICK NAILHEAD
AS SEEN IN **CAR CRAFT**

BUICK NAILHEAD FUEL INJECTOR

The Nailhead was the hot lick when dragsters with multiple engines would smoke the tires all the way down the quarter. There wasn't a sight more awesome than the dragster of Tommy Ivo bellowing smoke off of all four tires powered by four nailheads.

This is the original design of the first Nailhead Buick fuel injector we made in the 1950's.....back by popular demand!

Fuel Delivery Options:

- Mechanical / Constant Flow
- **EFI**

Engine Application:

- 324", 364", 401" (1957-1966)

Standard Features:

- high quality heat-treated aluminum casting
- cad-plated steel ram tubes
- fully assembled with shafts, butterflies, linkage
- MECHANICAL model includes metering valve, nozzles, fuel lines, and primary/secondary bypass valves.
- EFI model includes split throttle shaft, fuel rails, mounted TPS with connector and vacuum kit

Options:

- polished castings
- chrome ram tubes
- powder coating
- port matching
- complete hand porting

PART NUMBERS

*324B8A Buick Nailhead Fuel Injector (2-1/16" bore)

*EFI324B8A/EL Buick Nailhead EFI Kit (2-1/16" bore)

Ram Tube Options:

F144 & F144D Steel Ram Tube (2-1/16")

Ram Tube Adapters with slip-in tubes available



FUEL INJECTORS FOR BLOWERS

DUANE EVAN'S '41 WILLYS COUPE

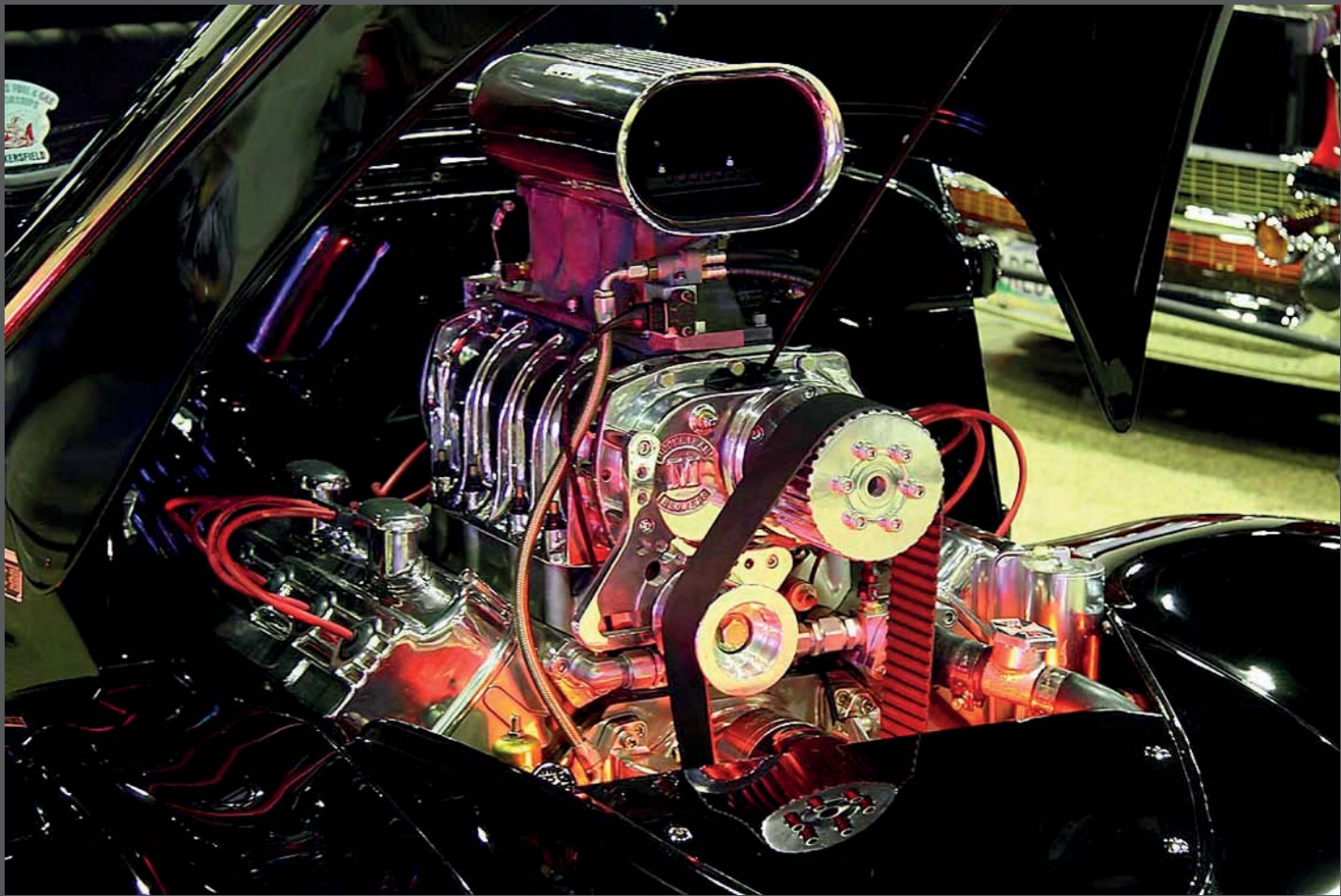

TALL 4-PORT 6-71 SCOOP STYLE FUEL INJECTOR

The Hilborn scoop style injector has made its mark in history as one of the most recognizable injectors for blown applications. It has seen duty on a bevy of nitro powered diggers, straight front axle gassers, and plenty of Bonneville record setters.

Fuel Delivery Options:

- Mechanical / Constant Flow
- **EFI**

Engine Application:

- 6-71 or 8-71 Blower applications

Bore Size:

- 2-3/8" or 3"

Dimensions:

- overall height with scoop is 10-5/8"
- 4-5/8" injector casting only

Standard Features:

- high quality heat-treated aluminum casting
- fully assembled with shaft, butterflies, linkage
- MECHANICAL model includes metering valve, 4 nozzles, fuel lines, and primary/secondary bypass valves.
- EFI model includes fuel rail, mounted TPS with connector and vacuum kit

Options:

- port nozzles can be added if fuel distribution is a problem.
- MECHANICAL model is also available with 8-nozzle set-up, and a high capacity metering valve
- EFI model also available with eight injectors using our 1.25 inch tall injector plate, designed for four nozzles and one fuel rail per side
- polished or clear anodized air scoop
- polished castings
- powder coating



TM671GMC
Air Cleaner fits inside AS-6A Scoop

PART NUMBERS

- *6-71 GMC-A 4-Port Fuel Injector, 4-nozzles
- OPT1 8-nozzles
- OPT2 8-nozzles and high capacity metering valve
- *EFI671GMC-A/EL2 4-Port 6-71 EFI Kit
- AS-6A Polished Air Scoop
- AS-6A/ANO Clear Anodized Air Scoop

Bore Sizes:

2-3/8" or 3"

Air Filter:

TM671GMC Air Filter



SHORT 4-PORT 6-71 SCOOP STYLE FUEL INJECTOR

Fuel Delivery Options:

- Mechanical / Constant Flow
- **EFI**

Engine Application:

- 6-71 or 8-71 Blower applications

Bore Size:

- 2-3/8" or 3"

Dimensions:

- overall height with scoop is 8-1/2"
- 2-3/4" injector casting only

Standard Features:

- high quality heat-treated aluminum casting
- fully assembled with shaft, butterflies, linkage
- MECHANICAL model includes metering valve, 4 nozzles, fuel lines, and primary/secondary bypass valves.
- EFI model includes fuel rail, mounted TPS with connector and vacuum kit

Options:

- port nozzles can be added if fuel distribution is a problem.
- MECHANICAL model is also available with 8-nozzle set-up, or with a high capacity metering valve
- EFI model also available with eight injectors using our optional one inch tall injector plate, designed for four nozzles and one fuel rail per side
- polished or clear anodized air scoop
- polished castings
- powder coating

PART NUMBERS

*6-71 GMC-B 4-Port Fuel Injector, 4-nozzles (2-3/8")

*6-71 GMC-F 4-Port Fuel Injector, 4-nozzles (3")

OPT1 4-Port Fuel Injector, 8-nozzles

OPT2 4-Port Fuel Injector, 8-nozzles and high capacity metering valve

*EFI671GMC-B/EL2 4-Port 6-71 EFI Kit (2-3/8")

AS-6A Polished Air Scoop

AS-6A/ANO Clear Anodized Air Scoop

Bore Sizes:

2-3/8" or 3"

Air Filter:

TM671GMC Air Filter

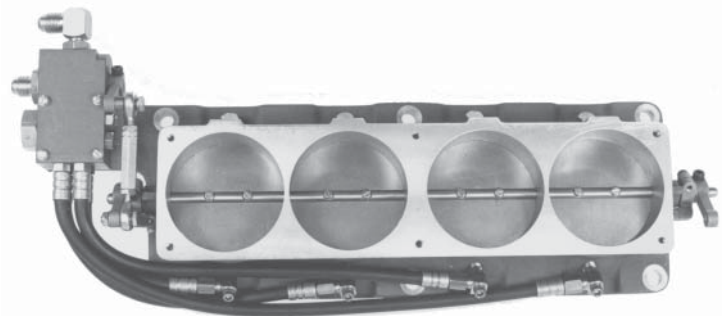

TM671GMC
Air Cleaner fits inside AS-6A Scoop



4-71 & 6-71 2-PORT SCOOP STYLE FUEL INJECTOR

Wouldn't it be great if you could have the classic Hilborn look for the 4-71 or 6-71 blower on your engine? Well now you can. Hilborn's 2-Port Scoop Injector is perfect for those wanting big boy power but in a smaller size.

Fuel Delivery Options:

- Mechanical / Constant Flow
- **EFI**

Engine Application:

- 4-71, 6-71 or 8-71 Blower applications

Bore Size:

- 3"

Dimensions:

- 4-71 overall height with scoop is 8-3/4"
- 6-71 overall height with scoop is 9"
- 4-71 and 6-71 injector castings only are 4-3/4"

Standard Features:

- high quality heat-treated aluminum casting
- fully assembled with shaft, butterflies, linkage
- MECHANICAL model includes metering valve, 2 nozzles, fuel lines, and primary/secondary bypass valves.
- EFI model includes fuel rail, mounted TPS with connector, vacuum kit.

Options:

- port nozzles can be added if fuel distribution is a problem
- also available with 4-nozzle set-up
- polished or clear anodized air scoop
- polished castings
- powder coating

PART NUMBERS

*4-71 GMC-A 2-Port Fuel Injector, 2-nozzles

*6-71 GMC 2-Port Fuel Injector, 2-nozzles

OPT1 4-nozzles

OPT2 4-nozzles and high capacity metering valve

*EFI471GMC-A/EL 2-Port 4-71 EFI Kit

*EFI671GMC/EL 2-Port 6-71 EFI Kit

AS-4A Polished Air Scoop

AS-4A/ANO Clear Anodized Air Scoop

AS-6 Polished Air Scoop

AS-6/ANO Clear Anodized Air Scoop



FUEL INJECTORS FOR BLOWERS



BLOWN FIAT ALTERED

4-HOLE HAT STYLE FUEL INJECTOR

In the days when slingshot dragsters on fuel were more than race cars (they were a way of life!) our 4-Holer was there.....and now you can relive that heritage. Its classic rib design and smoothly rounded and polished casting takes you back to a time when beauty was as important as function.

Large butterflies are for big power but can be difficult to drive on the street, so we've modified the 4-Hole Hat by installing block-off "buckets" that are placed behind two butterflies, effectively reducing the butterfly area by half, providing excellent street manners and plenty of air for 1000+ horsepower!

For EFI applications, our 1.25 inch tall injector plate, designed in house at Hilborn Fuel Injection, hides the injectors under the hat for a sleek and clean look.

Fuel Delivery Options:

- Mechanical / Constant Flow
- **EFI**

Engine Application:

- 6-71 or 8-71 Blower applications

Dimensions:

- overall height with nozzle plate is 6"
- 4-3/4" injector hat only

Standard Features:

- high quality heat-treated aluminum casting, polished
- fully assembled with shaft, butterflies, linkage
- MECHANICAL model includes metering valve, 8 nozzles, fuel lines, and primary/secondary bypass valves.
- EFI model includes fuel rail, mounted TPS with connector and vacuum kit

Options:

- port nozzles can be added if fuel distribution is a problem.
- hard line kit
- MECHANICAL model is also available with a high capacity metering valve

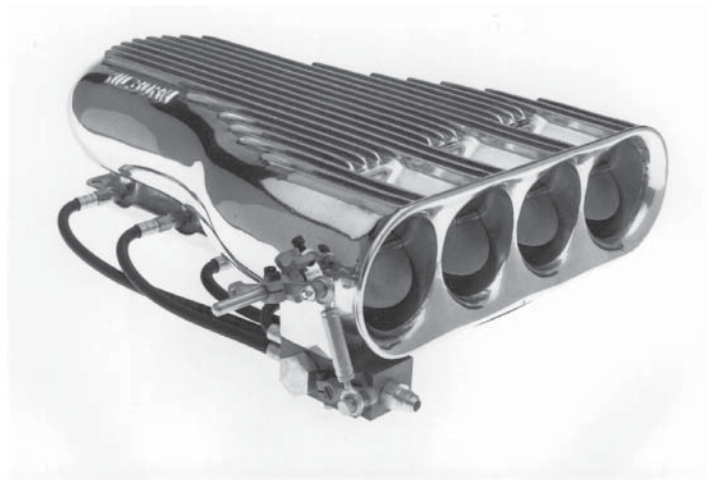

PART NUMBERS

- *6-71 GMC-E 4-Hole Hat Fuel Injector (3" bore), 8 nozzles OPT1 with 8 nozzles and high capacity metering valve
- *EFI671GMC-E/EL 4-Hole Hat EFI Kit (3")

- EFI model also available with eight injectors using our optional one inch tall injector plate, designed for four nozzles and one fuel rail per side
- simulated carbon fiber powder coating



SHOT GUN HAT FUEL INJECTOR

This is it!...the original Hilborn Shot Gun injector. Others have tried to imitate it, but this classic design has never been truly copied. We offer the Shot Gun in fully polished aluminum, or in light-weight magnesium with a simulated Carbon Fiber finish for a wild and updated look.

Large butterflies are for big power but can be difficult to drive on the street, so we offer the Shot Gun in a smaller butterfly bore size, providing excellent street manners and plenty of air for 1000+ horsepower!

For EFI applications, our 1.25 inch tall injector plate, designed in house at Hilborn Fuel Injection, hides the injectors under the hat for a sleek and clean look.

Fuel Delivery Options:

- Mechanical / Constant Flow
- **EFI**

Engine Application:

- 6-71 or 8-71 Blower applications

Bore Sizes:

- 3-5/8" or 5-1/4"

Dimensions:

- overall height with nozzle plate is 8"
- 6-3/4" injector hat only

Standard Features:

- high quality heat-treated aluminum or magnesium casting
- fully assembled with splined shaft, butterflies, linkage
- MECHANICAL model includes metering valve, 8 nozzles, fuel lines, and primary/secondary bypass valves.
- EFI model includes fuel rail, mounted TPS with connector and vacuum kit

Options:

- port nozzles can be added if fuel distribution is a problem.
- hard line kit
- MECHANICAL model is also available with a high capacity metering valve



PART NUMBERS

*6-71 GMC-H 8-nozzles (3-5/8" or 5-1/4")

OPT1 with 8 nozzles and high capacity metering valve

*EFI671GMC-H/EL Shot Gun EFI Kit (3-5/8")

Air Filter:

AF671H Shot Gun Protection Air Filter

- EFI model also available with eight injectors using our optional one inch tall injector plate, designed for four nozzles and one fuel rail per side
- simulated carbon fiber powder coating



Shot Gun Hat with Hard Line Kit



Shot Gun Protection Air Filter



HAT CONVERSIONS TO EFI

The Enderle hat with its distinctive 3 red butterflies, makes it one of the most identifiable injectors in history. Dominant in the fuel and alcohol classes for years, an Enderle on your supercharger will let everyone know you mean business. We recommend the smallest of the Enderle hats, the Bug Catcher, for most street rods, although the Bird and Buzzard are available for specific high horse power applications.

Our 1.25 inch tall injector plate, designed in house at Hilborn Fuel Injection, hides the injectors under the hat for a sleek and clean look like the mechanical injectors of yesterday. There are no injectors sticking out of the sides to ruin that "pure" look. Ingenious in design, it places fittings for fuel, vacuum, and injector wiring out of the rear of the plate for a cleaner look. Top it off with our optional mechanical hard line kit for the most authentic racing look around. Our injector plate can also be configured with eight external injectors and dual fuel rails.

This adapter plate fits 6-71 and 8-71 blower applications and can also be used to convert mechanical hat-type injectors to **EFI**.

CONTACT OUR EFI SPECIALIST FOR INFORMATION AND PRICING ON HILBORN OR ENDERLE HAT CONVERSIONS





1968 CHERRY BOMB CAMARO
BUILDER: **YEAR ONE**

FUEL INJECTORS – SINGLE THROATS

BRET PETERSON'S NITRO INJECTED 950 KTM
2012 N.A.H.A. 450 Pro, X CLIMB & OPEN EXHIBITION CLASS NATIONAL HILLCLIMB CHAMPION
PHOTO COURTESY [PETERSON FAMILY RACING](#)



SINGLE THROAT FUEL INJECTORS

This basic Single Throat Injector unit is designed for a one cylinder engine. For each additional cylinder, another Extra Single Throat unit is added which allows for change in engine configurations at minimum cost.

Fuel Delivery Options:

- Mechanical / Constant Flow

Standard Features:

- high quality heat-treated aluminum casting
- fully assembled with shaft, butterfly, & linkage
- Extra Single Throats are fully assembled without a metering valve

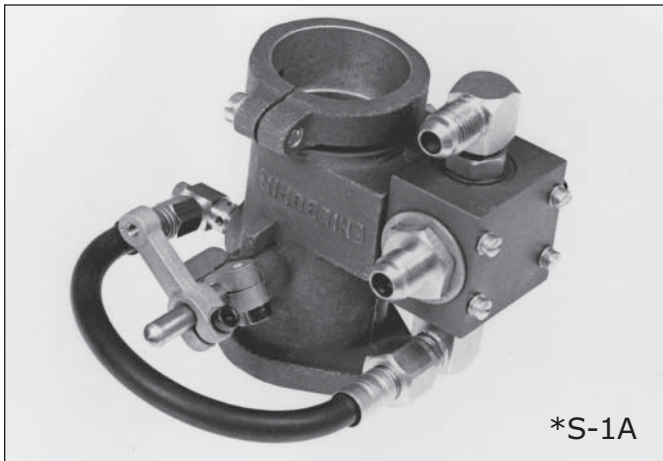

*S-1A

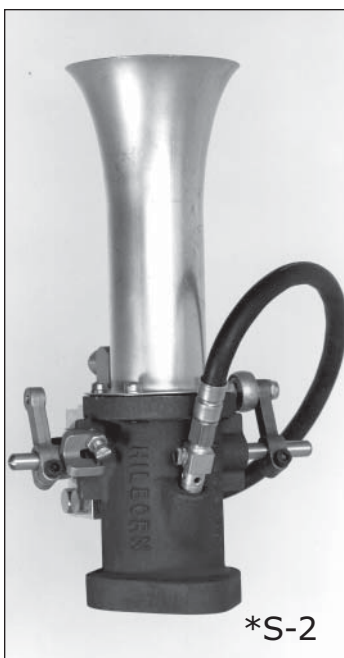

*S-2



*S-26

PART NUMBERS

- *S-1A (1-9/16" bore), *S-1AX Extra Throat
- *S-2 (1-11/16" bore), *S-2X Extra Throat
- *S-23 (2-7/16" bore), *S-23X Extra Throat
- *S-24 (2-7/8" bore), *S-24X Extra Throat
- *S-24B (3" bore), *S-24BX Extra Throat. This model features a V-band flange
- *S-25A (2-1/16", 2-3/16" bore), *S-25AX Extra Throat
- *S-25A-Option 1 fits Harley Davidson
- *S-26 (2-1/2" bore), *S-26X Extra Throat
- *S-26-Option 1 fits Harley Davidson

Ram Tubes:

- F835 Steel Ram Tube (1-11/16")
- F941A Aluminum Ram Tube (1-9/16")
- F942 Steel Ram Tube (2-1/16")
- F943 Steel Ram Tube (2-3/16")
- F947 Steel Ram Tube (2-7/16")
- F948A Aluminum Ram Tube (2-1/2")
- F954A Aluminum Ram Tube (2-7/8")

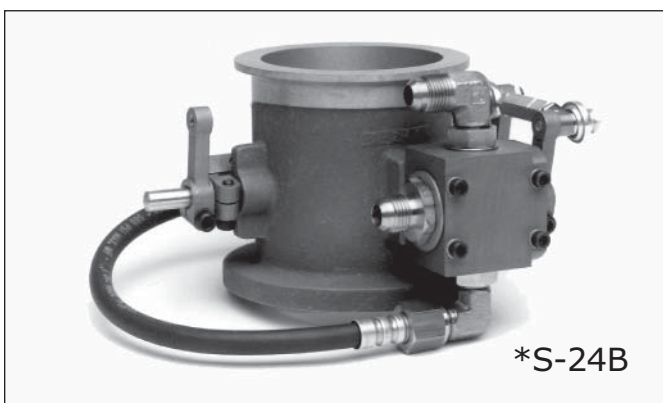

*S-24B



TURBOCHARGED APPLICATIONS

In the early 1960's Hilborn developed a new fuel injection system for turbocharged engines and was able to introduce this technology to the Indianapolis 500 race. In a very short time, every car in the Indy 500 was turbocharged and Hilborn injected. All of the fuel injector models we manufacture today can be set-up for turbocharged applications.

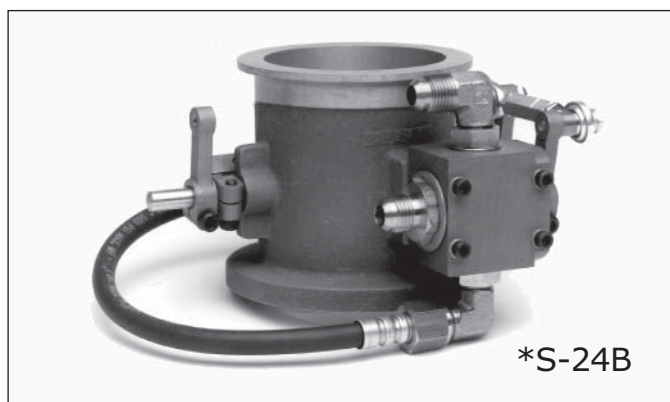

Single Throat Injectors:

- *S-24B 3" bore, features a V-band flange
- *S-24BX Extra Throat

Part Nos.

- *F510 #4 By-Pass Valve: richens and leans the unblown system with no boost.
- *F510-5 #5 By-Pass Valve: Functions as a hi-speed cut-off valve for turbo applications. This valve by-passes the Sensor Valve.
- *END510A Air Valve: Jets air to the Sensor Valve from the plenum. This valve richens & leans the engine under full boost.
- *END510E Economizer Valve: Keeps the engine lean on unblown system using larger size nozzles.
- *END510R Enrichment Valve
- *END510P Port Valve
- *F535AX Sensor Valve (5/8"): A boost compensator. This valve senses boost, richens & leans the engine under boost.
- *F535BX Sensor Valve (1/2"): A boost compensator. This valve senses boost, richens & leans the engine under boost.
- F513A-1 Drilled Poppet
- *F522 #8 Port Check Valve
- *F522B #8 By Pass Valve
- *F522BX #Hi Speed Cut Off Valve

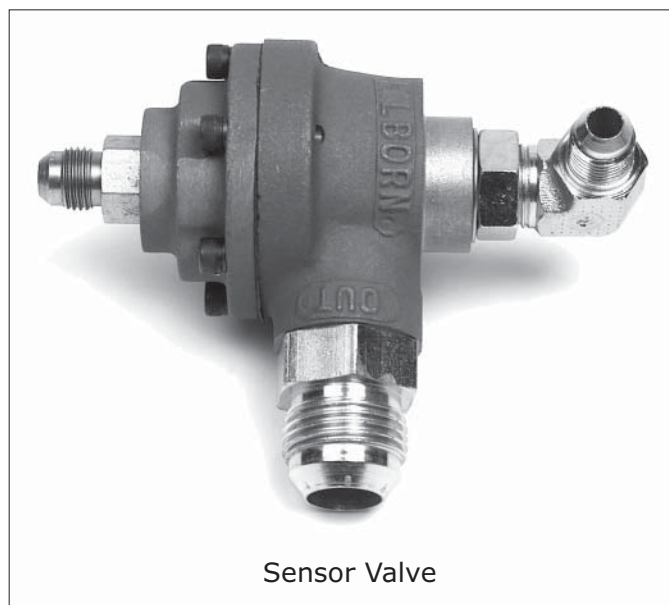

JORAN PERSAKER'S TWIN TURBO PRO MOD
PHOTOS COURTESY **PERSAKER'S SPEED SHOP**



COMPLETE EFI KITS

Our EFI kits contain the highest quality components which are engineered to work together to provide the best EFI experience possible. Each kit is custom designed for your application at an off the shelf price. No one delivers better value than Hilborn Fuel Injection.

8-STACK INDIVIDUAL RUNNER MANIFOLDS

The Hilborn EFI Injector is an engineered manifold that does not require welding like "conversions" which can affect the manifold's structural dimensions. Instead, our manifolds are designed at the foundry level to accept the required EFI components. The heat treated casting is completely machined in house before receiving a clear anodize, resulting in a nostalgic gray finish while providing surface protection. Optionally, we provide a selection of custom finishes such as polishing or powder coating. Assembly of the manifold includes installing the split shafts and butterflies along with the mounted TPS, fuel rails, injectors and vacuum kit. Pressure testing the fuel rails for leak free performance completes the in house assembly process.

ELECTRONICS

The electronics are the heart of any EFI system and we offer two of the best. Depending on the application and customer preference, we will use either the Holley HP/Dominator or FAST XFI system. The kit comes with the ECU and all the required sensors such as MAP, Coolant, Air Temperature and Wide Band O2. Wiring harnesses for the specified application are supplied and a base program for the ECU is designed.

FUEL SYSTEM

We tested numerous fuel pumps before finding

what we consider the finest fuel pump in the aftermarket. Weldon Pump's reputation in the racing and aviation industry is only surpassed by the quality of the product that they produce. We use their A600A pump on applications up to 750hp and their 1100A for applications up to 1200hp. These pumps feature whisper quiet performance and a lifetime warranty you'll never need. In addition, the A600A uses less than 5 amps at 50psi, making it the lowest amperage draw in the industry. A Weldon 2040 regulator provides rock solid pressure settings while a pair of our own fuel filters rounds out the fuel system. As with the rest of the kit, we provide application specific design of the fuel system, while also supplying inlet/outlet fittings for the pump, regulator and filters, along with a fuel schematic to guide installation.

ACCESSORIES

Race inspired Hilborn Injector manifolds do not have provisions to accept a thermostat, so the use of a remote thermostat housing is required. The remote housing included in the kit accepts a Chevrolet style thermostat and water neck. For fine tuning, a sychrometer is recommended and is supplied in every kit.

PERFORMANCE

A Hilborn Injector is part of the IR (individual runner) family and does not suffer from the disruptive cylinder to cylinder pulses associated with a common plenum intake. These pulses promote fuel separation from the air carrier, the slowing of air movement in the manifold, and the inability to realize true engine potential due to poor burn characteristics in the combustion chamber. The IR design of the Hilborn isolates these pulses, allowing the engine to make more bottom end torque, have increased throttle re-



sponse and, most importantly, allows the engine to accelerate faster. Most applications will also see a significant increase in top end power. These same attributes also allow smoother low speed drivability.

TECH SUPPORT

All Hilborn products are backed with support from our easy to reach, friendly and knowledgeable technicians. When you purchase one of our EFI systems, you get free lifetime technical support. Additionally, we have created videos that detail manifold adjustments and tuning, available from the Tech Support section of our web site. Our goal is to make sure that you have a fantastic EFI experience.

PRICING

We are happy to provide a detailed line item quote specific for your application. As a volume distributor, we can offer vendor supplied components at the same, or better, pricing as mail order. Throw in our top notch tech support and we have the best deal around.

MADE IN THE USA

All Hilborn manufactured products are proudly made in USA.

HOLLEY EFI

We are proud to offer the Holley line of ECUs and fuel injection components. Focusing on the Holley HP, this ECU offers premier fuel and spark control, while also giving the user the option to tune with or without a laptop using the Avenger Handheld. In addition, advancements in self learning make the Holley HP one of the easiest ECUs to use, while still providing all of the control required by the professional.

Self learning is all the rage and the Holley HP self learn is one of the best that we've used and can tune IR manifolds such as a Hilborn without trouble. Even applications with aggressive camshafts can successfully take advantage of Holley's self tuning programming.

HOLLEY AVENGER™ HANDHELD

The choice is yours! The Avenger Hand Held from Holley allows those who are anxious about lap top control the ability to access the major parameters of the ECU using intuitive menus with a simple click to change programming. When purchased as a Holley/Hilborn IR EFI system, a base calibration custom designed for your application will already be downloaded to your ECU. With the hand held controller, adjustability of the HP ECU is right at your finger tips.

Standard Features:

- Target Air/Fuel values for idle, cruise and WOT
- TPS Autoset
- Fuel injector size and fuel system pressure
- Spark Parameters
- IAC Control
- Learn Parameters
- Sensor monitoring
- Coolant enrichment
- MAP and TPS acceleration enrichment
- Closed Loop Parameters
- Idle Parameters
- Cranking and afterstart fueling
- Datalogging



HOLLEY HP™ ECU

For applications that require lap top access, or for those that prefer it, the HP has many features that make it one of the most versatile ECUs on the market. Easy to navigate software and a trouble free USB connection allow you to tune like a pro in no time.

The Holley software can easily be downloaded for review.

After downloading, accessing the "help" file will allow you to view detailed installation instructions along with wiring schematics, pin out charts and tuning instructions. After purchase, the professionals at Hilborn Injection will create a base startup program for your application and supply detailed tuning tips, along with providing the very best in technical support.

Standard Features:

- Easy to use software
- Optional 5.7" full-color touchscreen LCD monitor
- Capable of driving 16 low impedance injectors
- Plug and play control of factory GM 24x and 58x LSx engines
- Scalable maps for maximum resolution
- Native USB connectivity and proprietary drivers eliminates finicky USB/Serial adapters
- 1-5 Bar MAP Compatibility
- Knock Sensor inputs
- Speed Density, Alpha -N, or combination fueling strategies
- 4GB internal data logging....standard feature!
- 4 Stage nitrous control
- Turbocharger boost control
- User configurable input/output programming
- Configurable for: dual cooling fans, dual fuel pumps, AC inputs, basic TCC lock up, and multiple timing and retard inputs and rev limiters
- And so much more!



DOMINATOR® EFI ECU

This powerful ECU has all the same features as the HP plus more.

Standard Features:

- Capable of driving 24 low impedance injectors with multiple staged injector strategies
- Twelve channel DIS outputs capable of directly driving "Smart" coils or Holley DIS coils
- Integrated electronic transmission control
- Integrated dual channel wide band oxygen sensor controls
- Integrated drive by wire controls capable of driving dual throttle bodies
- Store and change between four calibrations, with the flick of a switch
- A massive 85 user configurable inputs and outputs
- Traction Control
- Uses same harnessing as the Avenger and HP ECU's for easy upgrade

FAST XFI 2.0 ECU

For those looking for premier fuel and spark control, we are proud to offer the FAST XFI 2.0, the most versatile ECU for beginners and professionals alike.

Using inputs from sensors such as MAP, coolant temp, air charge, O2 and TPS, the XFI can tailor the fuel and spark curve at any load, rpm, or boost level, providing the ultimate in efficiency and drivability. You will also find that the XFI is as comfortable on the race track as it is on the street.

Tuning of the XFI through it's Windows based software is years ahead of older systems, allowing even the novice to quickly become comfortable with all tuning aspects and now, with its self learning auto tune VE table, a base table can easily be populated just by driving the car. The C-Com software can be easily downloaded for review.

The supplied C-Com software disc includes a help file that contains detailed installation instructions along with wiring schematics, pin out charts and tuning instructions. After purchasing, the professionals at Hilborn Injection will create a base startup program for your application and supply detailed tuning tips, along with providing the very best in technical support.

FAST drop-in distributors take the guesswork out of running your EFI system in sequential mode. These plug and play distributors have the required cam and crank outputs along with

automatically compensating for crank reference angle and rotor phasing. They are available for most applications.

Standard Features:

- Built in wide-band O2
- Full sequential and/or bank to bank capability
- Speed density or Alpha N
- Open/closed loop operation
- High/low impedance injectors
- Individual cylinder correction
- Fan and fuel pump control
- 1,2,3 and 5 bar MAP capability
- Diagnostic lights
- Power adder features
- IAC control
- External data logging (requires laptop)
- Multiple calibration files available via toggle switch (no laptop)
- Self Learning Auto Tune VE Table
- User Adjustable Battery Voltage Injector
- Opening Correction Table
- Fixed Timing "TEST" Mode: easy verification of ignition timing accuracy
- Spark vs. Coolant Temp Offset Table
- User Configurable Target Air Fuel Offset Table vs. Coolant Temp Table: more accurate warm-up enrichment
- User Selectable Safety Feature: deactivates all power adder features in event of fault code
- Automatic & Manual TPS Calibration Modes
- Additional Transbrake Control Features
- Improved On-Board Diagnostics
- Advanced Forced Induction, Power Adder & Race Controls

Optional Features:

- Transmission control
- Coil over plug, DIS ignition control
- Internal data logging
- Traction control



WELDON RACING COMPONENTS

Industry wide, the Weldon Racing Pumps name has been synonymous with top quality fuel delivery components....but we've heard this claim before about a wide variety of aftermarket suppliers. Knowing that the fuel system components would reflect the quality of the EFI kits produced by Hilborn, we elected to test the fuel delivery components from various manufacturers. Our testing found that the components from Weldon Racing Pumps were not only the most consistent, they routinely out performed their published spec information. Weldon Pumps are so reliable, they now have a Limited Lifetime Warranty, which we can boastfully say you will never need. This is why Weldon Racing Pumps is the choice for all of Hilborn Fuel Injection's EFI kits.

As a volume Weldon Distributor, we can offer you the complete Weldon line of products. Let our experienced staff design a fuel system just for you.

Features of both A600A and 1100A :

- Includes lifetime warranty from Weldon
- Extremely quiet
- Smooth, precise fuel delivery
- Extremely low current draw
- Self priming - pump may be mounted above fuel cell, vertical or horizontal mount
- All internal wear components are 100% metallic, no plastic or composite materials are used. Internal pumping elements are made of high speed tool steel and bronze. This results in the longest lasting, highest quality, most durable flow through pump available.
- The housing is made from corrosion resistant 304 brushed stainless steel
- Weldon anodized billet end caps with No-Leak seals
- -10 inlet and outlet leak free o-ring ports
- Two stainless steel T-bolt style clamps included
- Long life, continuous duty

Options:

- Black anodized aluminum inlet & outlet fittings

WELDON A600A FUEL PUMP

If you are looking for a pump that is unmatched in performance and reliability then it has to be the Weldon A600A. With extremely low amperage draw, high gph/psi flow rating and whisper quite operation, the 600A has the ability to reliably support combinations making over 750hp. It weighs in at 5.25 lbs.

Maximum Horsepower Rating:

750 hp Inj/800+ hp Carb

Current Fluids:

Compatible with Gasoline with a E15 limit



WELDON 1100A FUEL PUMP

The 1100A pump shares the same physical size as the A600A but can supply enough fuel to support an amazing 1200hp, while retaining features such as low amperage draw, high gph/psi flow rating and whisper quite operation. It weighs in at 6.25 lbs.

Maximum Horsepower Rating:

1200 hp Inj/1300+ hp Carb

Current Fluids:

Compatible with Gasoline with a E15 limit



WELDON 2040 REGULATOR

We believe the Weldon A2040 regulator to be the finest regulator on the market, being fully adjustable and providing rock steady pressure on or off the throttle. Larger than other regulators at .281 inches, this bypass orifice size allows fast and smooth response without causing a restriction that could potentially heat the returning fuel. This and numerous other advantages make the 2040 the best by-pass style regulator available.

Features:

- Includes lifetime warranty from Weldon
- Fastest response rate
- Provides stable fuel delivery for the most demanding requirements
- All Weldon Regulators maintain steady fuel delivery during dramatic changes in fuel demand, such as WOT conditions, boost application and gear changes
- Fully adjustable from 4-200 psi
- .281" bypass orifice
- Hardened steel ball and replaceable steel seat
- Fluorosilicone diaphragm
- Compatible with most racing fuels including ethanol, and methanol.
- 1/8" NPT Gauge Port
- 1/8" NPT manifold pressure reference port
- Fuel pressure increases on a 1:1 ratio with boost
- Two -10 pressure ports
- -8 return port
- Replaceable / interchangeable internal components
- For use with all Weldon Pumps as well as pumps from other manufactures
- Mil-Spec clear anodized cover

Options:

- Black anodized aluminum inlet & outlet fittings



WELDON PRODUCT LINE

As a volume distributor, Hilborn Fuel Injection supplies the entire Weldon Pump Line including:

- DB2015-A, 1000+ hp gas, 500hp Methanol
- DB2025-A, 1400hp gas, 700hp Methanol
- D2035-A, 1800hp gas, 900hp Methanol
- 14000 Fuel Pump Controller



REMOTE THERMOSTAT HOUSING

This EFI kit component allows for easy relocation of existing thermostat away from the intake manifold and uses Chevrolet water outlet, thermostat, & gasket. Choose from two models.

Part No.

EL128 Polished Cast Aluminum
MOR63427 Black Anodized Billet Aluminum



Y-BLOCKS & PRESSURE GAUGE

Cast in aluminum to fit your era themed car, this Y-block features leak free, o-ring straight thread fittings (available in -6, -8, or -10 sizes) which means no leaky pipe threads to worry about. The body also features predrilled tabs for mounting and a choice of three inlet/outlet locations. Choose either the clear anodized finish or the stunning polished finish for the ultimate look. The Y-Block can be used for fuel or coolant or for any other fluid application. Available with or without the 60psi fuel pressure gauge. The liquid filled gauge measures 1-3/4" outside diameter and has 1/8" NPT center back connection.

Part No.

*F549 Clear Anodized Y-Block & Fittings
*F549131 Anodized Y-Block & Pressure Gauge
*F549P Polished Y-Block
*F549131P Polished Y-Block & Pressure Gauge
EL131 Pressure Gauge, 0-60psi



SYNCHROMETER

The advantages of a Hilborn injector are many but in order to maximize its potential, synchronization of the butterflies is required.

Used in the last step of the synchronization process described in our tech support document, Injector Manifold Adjustments, the synchronometer insures that all cylinders have the same amount of air in the idle position. When correctly adjusted, the end result will maximize throttle response, part throttle drivability and give the exhaust the sound you expect from your hot rod engine.

The Synchronometer can be used with any individual runner manifold, injected or carbureted, and is supplied with any Hilborn EFI injector manifold kit purchase.

Part Nos.

STESK fits small bore sizes up to 2-1/16"
STEBK fits 2-7/16" to 2-5/8"
STEBKM fits 2-3/16"
STEBK-1 Grommet adapter attaches to STEBKM to extend the fit for 3"



THROTTLE BODY / MULTI PORT EFI

Hilborn is your one stop for all of your fuel injection needs....not only the best source for Individual Runner EFI systems but also for Throttle Body or Multi Port EFI applications.

Within the featured Holley line of products, there is something available for the novice all the way to the seasoned tuner. Pick the product that works for you or let us help you choose and know that you'll be covered by the best technical team in the industry.

TERMINATOR™ EFI 4BBL TBI

An EFI System so easy and powerful you'll think it's alive! Simply bolt it on, feed it a few basic answers and let Terminator EFI take control of your ride. System includes: TBI unit, handheld programmer, wiring & all sensors.

Features:

- fully self-tuning ECU - no laptop required
- self-tunes instantly to deliver the perfect air/fuel mixture in real time for optimized fuel economy and power
- virtually maintenance free - keeps your vehicle reliable and ready to drive
- 950 CFM Throttle Body with CFD computer designed venturi taken from Holley's famous NASCAR® throttle body - as found on all NASCAR Sprint Cup Series™ cars
- patent pending annular discharge fuel ring for maximum flow and optimum fuel atomization - no restrictions or delay in fuel flow like booster designs
- serviceable sensors integrated into throttle body and pre-wired for a simple one-click connection - don't get stranded by competitive designs
- connections for Ford, GM TH350 and 700R4, and other transmission linkages
- fits any square (Holley 4150™) flanged intake
- 80 lb/hr injectors support 250-600 HP engines
- provides ignition timing control on engines with Small Cap HEI and Ford TFI distributors (requires adapter)
- ECU fully potted and sealed for protection from vibration, dust and moisture
- Terminator ECU can be EASILY updated to Holley "HP"

ECU specs with a FREE online software download. ECU can then be used for LSX, boosted, nitrous, and many other applications in the future as you desire!

- trouble-free performance with today's fuels - put an end to vapor lock and fuel varnish problems!
- industry leading tech support - FREE!



PART NUMBERS

- #550-405* Terminator™ EFI 4 BBL TBI, Tumble Polished
- #550-406* Terminator™ EFI 4 BBL TBI, Hard Core Grey

* Does not include fuel pump, fuel lines, regulator or filters



HOLLEY AVENGER™ SYSTEMS

Features:

- "Bolt on and Go" - Complete plug & play EFI systems
- self-tuning technology tunes while you drive! It's the easy EFI solution
- includes full color LED hand-held controller allowing users to change parameters for fine tuning...no laptop required
- ideal for the enthusiast making the switch to EFI. It includes all hardware to retrofit from a carburetor to EFI including the fuel pump
- allows for computer controlled timing if desired
- can be upgrade in the future to HP EFI System
- available in TBI, 4bbl MPFI or Stealth Ram systems

AVENGER™ EFI 2BBL, 4BBL TBI SYSTEMS

Replace your carburetor with a "Bolt on and Go" TBI system. Avenger EFI throttle body kits are a direct replacement for a carburetor. Plug and play connectors make installation a snap and the Avenger's self-tuning capabilities will have you up and running in no time. Kit comes with all necessary parts for a complete installation. All set-up is done on the included hand-held tuner so no laptop is required.



PART NUMBERS

Avenger™ EFI 2 BBL TBI Systems

#550-200 670 CFM 2BBL TBI for V-8 engines up to 275hp

Avenger™ EFI 4 BBL TBI Systems

#550-400 700 CFM 65 lb/hr injectors 200-400 HP
#550-401 900 CFM 75 lb/hr injectors 375-525 HP
#550-400 900 CFM 85 lb/hr injectors 450-600 HP

AVENGER™ EFI 4BBL MULTI- POINT SYSTEMS

Avenger Multi-Point EFI systems for small or big block Chevys are ready for the street or strip with the simple swap of an intake. Whether you have a stock engine, crate or custom-built engine, Avenger Multi-Point systems can help you maximize performance, and the Avenger's self-tuning capabilities will get you to the cruise or race in no time. Systems include: intake manifold, billet throttle body, ECU, wiring harness, fuel rails, injectors, fuel pump and related small parts. Set-up is done on the included hand-held tuner so no laptop is required.



AVENGER™ EFI STEALTH RAM™ SYSTEMS

You're sure to get some attention when you pop the hood and show an Avenger Stealth Ram™ Multi-Point EFI system. Available for traditional or Vortec headed SB Chevys, the Avenger's self-tuning capabilities make it easy as 1, 2, 3 to get your car up and running with EFI. The tunnel ram design of the Stealth Ram builds excess power in the upper RPM while maintaining excellent mid-range torque as well. Systems include: intake manifold, billet throttle body, ECU, wiring harness, fuel rails, injectors, fuel pump and related small parts. Set-up is done on the included hand-held tuner so no laptop is required.



PART NUMBERS

Avenger™ EFI Single Plane 4 BBL Small Block Chevy Multi Port EFI Systems

#550-811 Early/Late heads, 36 lb/hr injectors up to 500 HP

#550-816 Vortec heads, 36 lb/hr injectors up to 500 HP

Avenger™ Single Plane 4 BBL Big Block Chevy Multi Port EFI Systems

#550-831 Std Deck, 1000 CFM, Rect Port 48 lb/hr injectors, up to 675 HP

#550-836 Std Deck, 1000 CFM, Oval Port 48 lb/hr injectors, up to 675 HP

PART NUMBERS

Avenger™ EFI Stealth Ram™ Small Block Chevy Multi Port EFI Systems

#550-821 Early/Late heads, 36/lb/hr injectors up to 500 HP

#550-822 Early/Late heads, 36/lb/hr injectors up to 500 HP, Polished

#550-826 Vortec heads, 36/lb/hr injectors up to 500 HP

#550-827 Vortec heads, 36/lb/hr injectors up to 500 HP, Polished



HP™ EFI

Programmable EFI Simplified!

Features:

- full featured systems with full laptop tunability plus self-tuning
- versatile capabilities to control power adders and other functions
- intuitive software is easy to use
- fuel table strategies based in either lbs/hr or VE
- ideal for LS engine swaps whether 24x or 58x. Plug and play with built in coil drivers
- ideal for street, drag race, road racing, off road and marine applications
- 1-5 Bar Map sensor capabilities, multiple IAC strategies, timing control options, speed density-Alpha N or mix, multiple injector sets, and more
- 8 user configurable inputs and outputs
- 4 GB of internal data logging memory
- 4 stage wet/dry Nitrous control, Water/Meth control and Turbo Boost control
- integrated USB and proprietary drivers for trouble free connectivity
- use with Holley DIS Ignition systems for complete spark control
- available in TBI, 4bbl MPFI or stealth Ram systems, plus stand alone ECU and harness kits

HP™ EFI 4BBL TBI SYSTEMS

Replace your carburetor with a "Bolt on and Go" TBI system that also allows you to tune as well. HP EFI throttle body kits are a direct replacement for a square flange carburetor. Plug and play connectors make installation a snap, and by utilizing a laptop (or the optional 5.7" full color touch screen LCD) along with the HP's self-tuning capabilities, you will be up and running in no time. System includes most all parts necessary for a complete installation including throttle body, ECU, wiring harness and sensors. Fuel pump and injectors are available separately to fit your requirements.*



PART NUMBERS

HP™ EFI 4 BBL TBI Systems

#550-411 900CFM 75 lb/hr injectors up to 525 HP

#550-412 900CFM 85 lb/hr injectors up to 600 HP

***NOTE: HP, MPFI and Stealth Ram systems do not include injectors or a fuel pump. Please contact the Hilborn EFI tech department for the correct components for your application.**

HP™ EFI 4BBL MULTI-POINT SYSTEMS

HP Multi-Point EFI systems for small or big block Chevys are ready for the street or strip with the simple swap of an intake. Whether you have a stock engine, crate or custom-built engine, HP Multi-Point systems can help you maximize performance. By utilizing a laptop (or the optional 5.7" full color touch screen LCD) along with the HP's self-tuning capabilities, the HP Multi-Point EFI system will get you to the cruise or race in no time. Systems include: intake manifold, billet throttle body, ECU, wiring harness, fuel rails, and related small parts. Fuel pump and injectors are available separately to fit your requirements.*



PART NUMBERS

HP™ EFI Single Plane 4 BBL Small Block Chevy Multi Point EFI Systems

- #550-810 Early/Late heads
- #550-815 Vortec heads

Single Plane 4 BBL Big Block Chevy Multi Point EFI Systems

- #550-830 Std Deck, 1000 CFM, Rect Port
- #550-835 Std Deck, 1000 CFM, Oval Port
- #550-833 Tall Deck, 1000 CFM, Rect Port
- #550-838 Std Deck, 2000 CFM, Rect Port
- #550-839 Tall Deck, 2000 CFM, Rect Port

HP™ EFI STEALTH RAM™ SYSTEMS

You're sure to get some attention when you pop the hood and show an HP Stealth Ram™ Multi-Point EFI system, available for traditional or Vortec headed SB Chevys. Simply utilize a laptop (or the optional 5.7" full color touch screen LCD) along with HP's self-tuning capabilities to make it easy as 1,2, 3 to get your car up and running with EFI. The tunnel ram design of the Stealth Ram builds power in the upper RPM while maintaining excellent mid-range torque as well. Systems include: intake manifold, billet throttle body, ECU, wiring harness, fuel rails and related small parts. Fuel pump and injectors are available separately to fit your requirements.*



PART NUMBERS

HP™ EFI Stealth Ram Small Block Chevy Multi Port EFI Systems

- #550-820 Early/Late heads
- #550-823 Early/Late heads, Polished
- #550-825 Vortec heads
- #550-828 Vortec heads, Polished

***NOTE: HP, MPFI and Stealth Ram systems do not include injectors or a fuel pump. Please contact the Hilborn EFI tech department for the correct components for your application.**



MECHANICAL FUEL PUMPS

These factory flow-tested mechanical fuel pumps can be used with gas, alcohol, or nitro applications. Rotation can be easily reversed to accommodate cam drives or belt drives.

The rigid cast aluminum body and high strength internals of our "C" pump eliminates failures!

While our billet "D" pump flows the same, it's smaller and lighter, making it the perfect choice for motorcycle applications or weight-conscious racers. A "Y" fitting which converts one (1) #8 outlet to three (3) #6 outlets is included.

Our newest "HP" pump shares the same features as the cast "C" pump but is specifically designed for high pressure applications, handling 125 to 160 psi.

Features:

- hard anodized, aluminum construction
- PG150C & PG150D pumps are offered with an optional clamp-on base design, allowing you the convenience of a quick disconnect and rotation for easy access to fittings.
- specify type of drive when ordering to ensure correct pump rotation



*PG150C "C" PUMP



*PG150CD "D" PUMPS

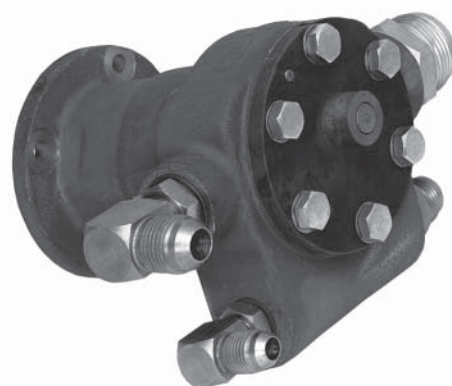

*PG175B PUMP

PART NUMBERS, SIZES & CAPACITY

PG150C/HP/CL High Pressure Cast Alum Pump with Clamp Base

PG150C Cast Alum Pump and PG150C/CL with Clamp Base

Sizes: #00, #0, #S0, #1/2, #1

The full range of flow capacity from sizes #00 through #1 is from .67gpm to 2.80gpm, rated at 1800rpm with 50psi

PG150D Billet Alum Pump and PG150D/CL with Clamp Base

Sizes: #00, #0, #S0, #1/2

The full range of flow capacity from sizes #00 through #1/2 is from .67gpm to 2.22 gpm, rated at 1800rpm with 50psi

PG175B, size #2 - capacity is 5.54 gpm rated at 1800 rpm with 50 psi.

PG175B, size #4 - capacity is 7.03 gpm rated at 1800 rpm with 50 psi

CHEVROLET PUMP DRIVES

Part No. for Small Block

- *PDC-4 Cam Cover Drive
- *PDC-4-2 Drive Spud Assembly only
- *PDC-6 Timing Belt Drive
- *PDC-6-1 Crank Spud Assembly, with belt

Part No. for Big Block

- *PDC-7 Timing Belt Drive - may be adapted to fit other engines by fabricating suitable mounting brackets and remachining the crankspud.
- *PDC-7-1 Crank Spud Assembly, with belt
- *PDC-8 Cam Cover Drive
- *PDC-4-2 Drive Spud Assembly only
- *PDC-10 Distributor Drive (tall deck only)

CHRYSLER PUMP DRIVES

Part No.

- *PDCH-3 Timing Belt Drive (426" Chrysler)
- *PDCH-5 Timing Belt Drive (SB Chrysler)

FORD PUMP DRIVES

Part No.

- *PDF-7 Timing Belt Drive (302 style 8.2 deck)
- *PDF-8 Timing Belt Drive (Pinto)

VOLKSWAGEN PUMP DRIVES

Part No.

- *PDV-1 Timing Belt Drive (VW)
- *PDV-2 V-Belt Drive (VW)

OLDS PUMP DRIVES

Part No

- *PDO-3 Timing Belt Drive for (F85, Buick, and 90° V-8 GM)

MISCELLANEOUS DRIVE PARTS

Part No.

- *F182-16 Timing Belt Pulley (crankshaft)
- *F182-32 Timing Belt Pulley (pump drive)
- ENDPDE Pump Drive Extension. Installs on front of the cam cover to give pump clearance from the blower belt. Lengths 2", 3", 4", 5", 6"
- BG270 Timing Belt, 27" long
- BG300 Timing Belt, 30" long
- BG322 Timing Belt, 32.2" long
- BG345 Timing Belt, 34.5" long



*F182-32 Pulley

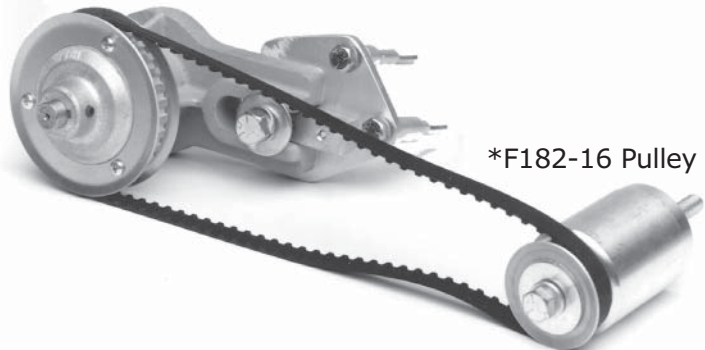

*PDC-6 Timing Belt Drive
(This combination drives the fuel pump at 1/2 engine speed)



PRIMARY BY PASS VALVE

Used for main mixture (idle pressure) control. It consists of a body, cap, poppet, spring, jet, and seal. It is usually installed in the line that originates at the fuel pump discharge and terminates at the fuel tank. The poppet acts as a check valve to hold pressure for starting and idle.

Part No.

*F510/A Aluminum By-Pass Valve

*END510 Brass By-Pass Valve

Primary By Pass Valve - Tech Link

TECH TIP: A .016 wire spring is the most commonly used, however, .020 and .024 are also available. Using a thicker wire spring will give more spring tension, resulting in a richer fuel mixture at idle and low rpm operation. The jet (pill) controls the amount of fuel the engine will receive at all rpm ranges. The larger the jet size, the more fuel is allowed to return to the tank, therefore leaning out the mixture. To richen the mixture, use a smaller jet size. To lean the mixture, use a larger jet size. Drop the jet into the valve so the number is visible to you. This side of the hole has been chamfered and is the side that fuel enters.

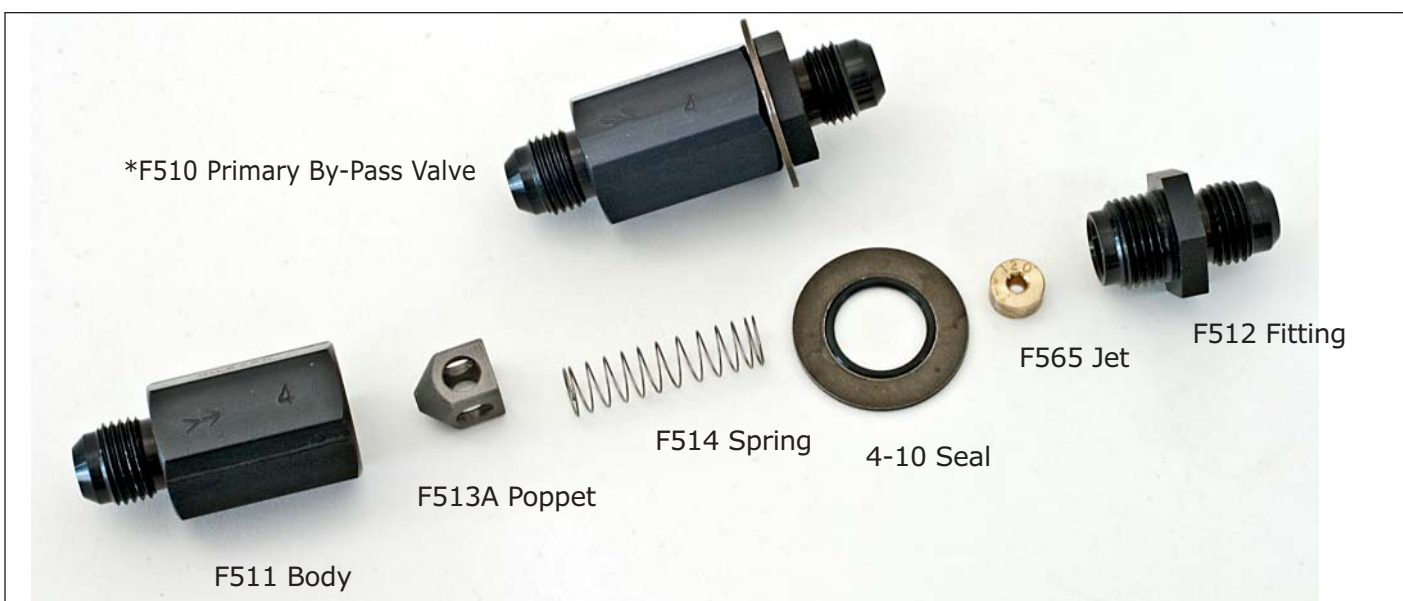

SECONDARY BY PASS VALVE

This valve is designed to control high rpm, closed throttle fuel pressure. It consists of a body, cap, poppet, spring, a .187" shim, and seal. The body is marked with the letter "S" and an arrow. It connects directly off the metering valve, with the arrow pointing toward the fuel tank. Since fuel flow is controlled mechanically by the metering valve, any open throttle position 25 degrees or more will automatically shut off the Secondary By-Pass Valve. This eliminates the possibility of a lean condition when throttle is open. Shims and springs can be added to change fuel pressure.

Secondary By Pass Valve - Tech Link

PART No.

*END510S Brass Secondary By-Pass Valve



HI SPEED CUT OFF VALVE

This valve is designed to control maximum rpm fuel flow curves by maintaining the air to fuel ratio required for good power throughout the whole rpm range. It is used mainly on large cubic inch engines that operate above 6000rpm, it consists of a body, cap, poppet, .042 spring, shims, and seal. The body is marked with the letter "C" and an arrow. When the valve is installed, the arrow should point toward the fuel tank. The valve is preset to open and relieve fuel when pressure is obtained, usually beginning around 6500rpm, and continues to open as rpm increases. The High Speed Cut-Off Valve can also be used as a simple pressure check or check valve for additional nozzles. It can be used to tailor a very rich bottom end fuel supply and a leaner top end curve. This valve can control the maximum pressure the engine will receive, conserving fuel for longer races.

TECH TIP: The point at which the Cut-Off Valve begins to open and relieve fuel can be adjusted by changing the various spring and shim combinations inside. Although fuel flow is controlled in other valves by changing jet size, affecting the total upper and lower fuel curve, the Hi Speed Cut-Off Valve controls the amount of fuel the engine receives at above peak power levels only.

Part No.

*END510C Brass High Speed Cut-Off Valve



CARBURETOR CHECK VALVE

This valve is designed to regulate fuel pressure for carburetors when using a mechanical fuel pump. The standard spring size is .024", however, adjustments can be made by changing the spring and shim combinations inside.

Part No.

*END510CV Carburetor Check Valve

MISCELLANEOUS BY PASS PARTS

Part Nos.

F510C-1	.030 Cut-Off Shim, brass
F510C-2	.187 Cut-Off Spacer, brass
F511	By-Pass Body, brass
F511A-4	By-Pass Body, aluminum
F512	By-Pass Cap, brass (with o-ring)
F512A	By-Pass Cap, alum (with o-ring)
F512-1	Metering Valve Fitting (for secondary by-pass valve)
F512-2	By-Pass Cap (no o-ring groove)
F513A	Aluminum Poppet
F514	.016 By-Pass Spring
F515	.024 By-Pass Spring
F516	.033 By-Pass Spring
F517	.045 By-Pass Spring
F518	.020 By-Pass Spring
F519	.028 By-Pass Spring
F523	.042 By-Pass Spring
*F514-F523	Spring Kit (1 each of the above)
F565P	Precision Machined By-Pass Jet (.020-.250 in .005" increments)
4-10	By-Pass Seal
*F1112	#6 Adapter for Secondary By-Pass Valve.



HILBORN
FUEL INJECTION

METERING VALVES

This valve coordinates the fuel with the butterflies, which controls the air to the engine. It consists of an anodized aluminum block, a metering rotor, a secondary outlet, and nozzle hose outlets. The metering rotor is selected to serve a wide range of engine sizes and fuel requirements, making it unnecessary to change rotor sizes when cubic inches change.

*Model-S

1 & 2 cylinder, side mount. This model can also be used with a junction block for multi-cylinder motors.



*VB-4 & *VB-4B

4 cylinder, side mount. See detail below for rotation differences.

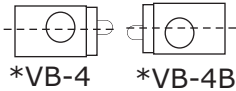

*VB-8

8 cylinder, side mount



*VB-8A

8 cylinder, bottom mount



*VB-8AA

8 cyl, o-ring sealed bottom mount

*VB-8AA-Option1

with pad & o-ring



*VB-8AA/FW

This machine contoured block is 50% lighter than the standard model. 8 cylinder, o-ring sealed, bottom mount, with aluminum fittings.



*VB-8EA

8 cylinder, side mount

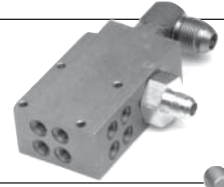

*VB-8G

8 cylinder, bottom mount



*VB-8GA

8 cylinder, o-ring sealed, bottom mount



***VB-8GA-Option1**
with pad & o-ring

*VB-8GA/FW

This machine contoured block is 50% lighter than the standard model. 8 cylinder, o-ring sealed, bottom mount, with aluminum fittings.



*VB-8U

8 cylinder, side mount



*VB-8W (High Capacity)

1 & 2 cylinder, side mount. This model can also be used with a junction block for multi-cylinder motors.



*VB-8Z

8 cylinder, bottom mount



*VB-16

8 cyl, 16 outlet, bottom mount

*VB-16-Option1

with pad & o-ring



IN-LINE FUEL FILTER

A small, lightweight, in-line fuel filter that weighs under 7 ozs. It will handle flows through our #1 size fuel pump. The stainless steel element is cleanable and never needs replacement.

- Specify 149 micron for mechanical applications or 74 and 25 micron for EFI

Part No.

- *F1200-8 Fuel Filter, #8 fittings
- *F1200-10 Fuel Filter, #10 fittings
- *F1200-12 Fuel Filter, #12 fittings

FUEL SHUT-OFF VALVES

2-way and 3-way manually operated fuel shut-off valves that are small and light, yet flow a full line size. Install this valve in line between the fuel pump outlet and the metering valve. When in the "off" position, the engine can be rotated to make valve adjustments or check timing marks without putting fuel into the engine. Cable clamp included.

Part No.

- END521B-6 2-Way Fuel Shut-Off Valve, #6(3/8")
- END521B-6 opt.1 2-Way, #6 (3/8" male flare on both ends)
- END521B-8 2-Way Fuel Shut-Off Valve, #8(1/2")
- END521B3-6 3-Way Fuel Shut-Off Valve, #6
- END521B3-8 3-Way Fuel Shut-Off Valve, #8

SINGLE GAUGE LEAK TESTER KIT

Single gauge leak tester gives a direct reading of the leakdown percentage instead of psi. No calculating needed! Kit includes three hoses for checking nozzles, metering valve, and cylinders.

Part No.

- *LT Leak Tester Kit



In-Line Fuel Filter

2-Way Fuel Shut Off Valve #6 or #8



3-Way Fuel Shut Off Valve #6 or #8



F524 cable clamp included



SCREEN TIP NOZZLES

Unless otherwise specified, all screen tip nozzles are available in 1/4", 1/2", 3/4", or 1" tip lengths.

Part No.

- *701AS 90° airbleed, 1/8 pipe thread
- *701SS 90° solid, 1/8 pipe thread
- *702AS straight airbleed, 1/8 pipe thread
- *702SS straight solid, 1/8 pipe thread
- *708AS straight airbleed, 1/2-20 thread, 3-5 o-ring
- *710AS straight airbleed, 1/2-20 thread, 3-5 o-ring available in 1-3/8", 2", 3 -1/2" , or 5-1/2" tips

DEFLECTOR TIP NOZZLES

Unless otherwise specified, all deflector tip nozzles are available in 1/2", 3/4", or 1" tip lengths.

Part No.

- *701AD-RH 90° airbleed, right hand, 1/8 pipe
- *701AD-LH 90° airbleed, left hand, 1/8 pipe
- *701SD-RH 90° solid, right hand, 1/8 pipe
- *701SD-LH 90° solid, left hand, 1/8 pipe
- *702AD straight airbleed, 1/8 pipe thread
- *702SD straight solid, 1/8 pipe thread
- *709AD straight airbleed, jam nut, 1/2-20 thread, #3-5 o-ring

NOZZLE BREATHER

Part No.

- *F1123 Nozzle Breather & Banjo, with #3-5 o-ring
- *F1123-1A Nozzle Banjo only



NOZZLE PLUG & O-RING

Part No.

- *F760 Nylon Nozzle Plug
- *F760A Black Aluminum Nozzle Plug, with #3-5 o-ring



RAM TUBES

We recommend the use of ram tubes on all models of our injectors. Horsepower gains of about 5% to 10% are average for a system with tubes.

- Available in various lengths

F100 SERIES (2-BOLT LUG MOUNT)

Standard flare, D-shape flare

Part No.

F142, F142D	1-11/16" ID, steel
F143, F143D	1-13/16" ID, steel
F144	2-1/16" ID, steel
F147	2-7/16" ID, steel



F800 SERIES (4-BOLT FLANGE MOUNT)

Standard flare

Part No.

F833	1-7/16" ID, steel
F847	2-7/16" ID, steel



F900 SERIES (PINCH CLAMP MOUNT)

Standard flare

Part No.

F933F	1-7/16" ID, steel
F941A	1-9/16" ID, aluminum
F935F	1-11/16" ID, steel
F936F	1-13/16" ID, steel
F940F	1-15/16" ID, steel
F942	2-1/16" ID, steel
F943	2-3/16" ID, steel
F943 A	2-3/16" ID, aluminum
F947	2-7/16" ID, steel
F947K	2-7/16" ID crimped, steel
F947A	2-7/16" ID, aluminum
F948A	2-1/2" ID, aluminum
F950AF	2-5/8" ID, aluminum
F954A	2-7/8" ID, aluminum



F1000 SERIES (PINCH CLAMP MOUNT)

D-shape flare:

Part No.

F1035	1-11/16" ID, steel
F1036	1-13/16" ID, steel
F1042	2-1/16" ID, steel
F1043	2-3/16" ID, steel
F1047F	2-7/16" ID, steel
F1047A	2-7/16" ID, alum
F1048A	2-1/2" ID, alum
F1050A	2-5/8" ID, alum
F1052A	2-3/4" ID, alum
F1054A	2-7/8" ID, alum
F1055A-040wall	2.9" ID, aluminum
F1055A	3" ID, aluminum

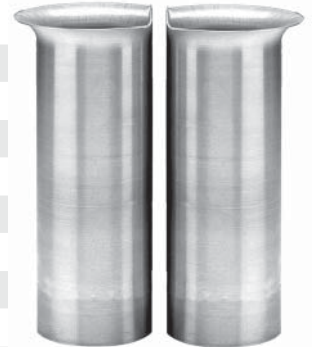

REDUCER RAM TUBES (PINCH CLAMP MOUNT)

This tube is swedged from 2-3/16" ID at the top to 2-7/16" ID at the bottom. (for use with injector model *327C8B)

Part No.

F104347 steel, D-shape flare



RETRO BELL RAM TUBES

Some Ram Tubes listed are also available with an old school Retro Bell top. Contact our office for more information.



RAM TUBE ADAPTERS

Make the switch to slip-in ram tubes! These ram tube adapters change the bolt-on ram tube mount of your older injector manifold to pinch clamp mounts. Photo shows how it's done using this 2-piece adapter.

NEW

Features:

- black anodized finish
- available for 2-bolt lug or 4-bolt flange style mounts in these injector bore sizes: 1-11/16", 1-13/16", 2-1/16", 2-3/16", or 2-7/16"
- pinch clamp slip-in style ram tubes sold separately



AS-4A 2-HOLE POLISHED AIR SCOOP

Polished cast aluminum scoop has two 3" holes. Fits our *4-71 GMC-A 2-Port Fuel Injector model.

- dimensions: 11-1/2" long x 4" high x 7-1/2" wide at opening.

AS-6 2-HOLE POLISHED AIR SCOOP

Polished cast aluminum scoop has two 3" holes. Fits our *6-71 GMC 2-Port Fuel Injector model.

- dimensions: 14" long x 4" high x 7-1/2" wide at opening.

AS-6A 4-HOLE POLISHED AIR SCOOP

Polished cast aluminum. scoop has four 3" holes. Fits our *6-71 GMC-A, B, or F 4-Port Fuel Injector models.

- dimensions: 18" long x 6" high x 9" wide at opening.



TM SPECIALTY AIR FILTERS

Proper filtration is a very important consideration for most, and we believe we have one of the nicest options available. Expertly crafted out of billet aluminum with machine polish finish, these filters feature 4" tall threaded billet ram tubes which allows for easy filter installation and removal. Available for specific SB Chevy, BB Chevy, 440 Chrysler Wedge, 426 Chrysler Hemi, 351 Ford Windsor, LS Chevy, & 409 Chevy injector models.

- 8" tall ram tubes available with some models
- ram tubes can be trimmed for height adjustment



TM671GMC Air Filter
fits AS-6A scoop



TM Air Filter/Ram Tube Combo unit available for specific Ford, Chevy, & Chrysler models

SHOT GUN PROTECTION

The Hilborn Shot Gun injector was designed to provide all the air your supercharged application could use. But without air filtration, the potential cost and damage caused by unchecked dirt entering your engine is very real. With that in mind, we have designed an air filter for the Shot Gun that provides the protection you want without compromising the airflow needed for performance driving.

Heading to the shows? The Shot Gun filter can be easily removed, without the need for tools, and replaced just as easily.

Features:

- washable filter media
- never needs oil
- no-mar urethane construction
- easy to install
- includes quick-release clamp
- excellent engine protection
- fits 5-1/4 in. or 3-5/8 in. butterflies
- for electronic or mechanical injectors



R2C PERFORMANCE AIR FILTERS

Savvy racers understand that maintaining a horsepower advantage at the checkered flag wins races. Testing has revealed that dust loaded filters can deprive your Sprint Car of up to 50 horsepower at race end. Now with R2C's patented filter technology, horsepower losses are greatly reduced at race end while still providing unmatched engine protection race after race. Starting with a dry synthetic media, R2C has removed the common oil media which is prone to attracting and holding dirt. A carbon fiber body captures this advanced media, while the ram tubes are sealed using a proprietary flange mechanically locked to the ram tubes for a worry free seal.

R2C synthetic filters are fully washable, but can be maintained trackside by directing 40-60 PSI compressed air outward from the inside surfaces.... in just minutes, they're ready to race over and over again!

Features:

- no more solvent cleaning, drying and oiling hassles.
- light weight carbon fiber body.
- six point latching system and dead soft urethane seal ensure a positive base seal and eliminates the troublesome mounting posts.
- ram tubes are sealed using a proprietary flange mechanically locked to the ram tubes to providing an air tight seal.
- no more grease or silicone!

K & N AIR FILTERS

Part No.

RD-440/4 (RAW Power 2-3/16" bore)

RD-460/4 (RAW Power, Mega Power 2-7/16")

RD-465/4 (RAW Power 2-1/2" bore)

RD-502/4 (Mega Power 2-1/2" bore)

RD-4669 (Mega Power 2-5/8" bore)

RD-480/4 (BB Chevy 2-7/8" bore)

RD-485/4 (BB Chevy 3" bore)



R2C Performance Air Filter System



TUBE TOP FILTERS

The rubber ring of this air filter slides over the top of ram tubes and holds the 3-piece screen element in place. The ring will stretch to fit diameters from about 2-7/8" to 3-1/4". Fits full round ram tubes only. Recommended for show car/street rod use, not for full race applications.

Part No.

IH-275 fits 2.50"-2.75" dia.

IH-325 fits 2.85"-3.25" dia.

RAM TUBE BOOTIES

Keep rocks and dirt out! This nylon bootie with elastic edge fits snugly around flared tubes. Fits full round or D-shape flared ram tubes. Recommended for show car/street rod use, not for full race applications.

Part No.

IH-B250 fits up to 2.50" dia.

IH-B325 fits up to 3.25" dia.

IH-B350 fits up to 3.50" dia.

OW202764 fits "D" bell F1055A Ram Tube 3"

RAM TUBE SEALS

Ram tube seals feature an aluminum flange allowing easy attachment of a base for custom air filter designs. Available for single or dual ram tube configurations.

Part No.

SEIT-3001 fits D-bell tubes 2-7/16" to 2-3/4"

SEIT-3002 fits D-bell ram tubes 2-3/16"

SEIT-3003 fits D-bell ram tubes with 3"

SEIT-404BL fits single ram tubes up to 2-3/8"

SEIT-SSI4.6 fits single ram tubes 2-3/8" to 3"

SEIT-SSI6 fits single ram tubes 2-3/16"



Tube Top Filters



Ram Tube Booties



Ram Tube Seals



HOSE LINES & FITTINGS

Part No.

*H3AB	3/16" ID Hose, female to male
*H3BF	3/16" ID Hose, male to 90°SS female
*H3BG	3/16" ID Hose, #3 male to #4 female
*H6AA	3/8" ID Hose, female to female
*H8AA	1/2" ID Hose, female to female
*H12AA	3/4" ID Hose, female to female
*3108	3/16" ID Hose, Male Hose Fitting
*4098A	3/16" Male Hose Fitting
*4108	3/16" Female Hose Fitting
F556S	3/16" Stainless 90° Hose Fitting

✓ specify length of hose line only when ordering

J-BLOCKS

Junction Blocks are used to relocate nozzle hoses when intake ports are some distance apart or several castings are used. They can be used on blown or unblown applications, also for water injector hookups and vacuum lines. Another common use of the junction block is the tunnel-port manifold with the use of a blower type hat.

Part No.

F538A	Junction Block, eight hose outlet
*F549	3-Way Junction Block, run as many as 3 valves into 1 return line to the fuel tank.
F555	Junction Block, four hose outlet
F1101	Junction Block, 16 hose outlet

THROTTLE LINKAGE PARTS

Part No.

*F101	Throttle Arm, bronze (specify 5/16", 7/16" or 3/8")
*F102	Throttle Stop, bronze (specify 5/16", 7/16" or 3/8")
*F104	Removable Throttle Arm, alum, 5/16"
*F105	Removable Drive Arm, alum, 5/16"
*F107	Drive Arm, alum, pinch clamp, 5/16"
*F60	Hex Link Assembly, includes rod end bearings. Specify length of hex rod from 5/8" to 13".
*F73A	Rod End Bearing, right hand
*F74A	Rod End Bearing, left hand

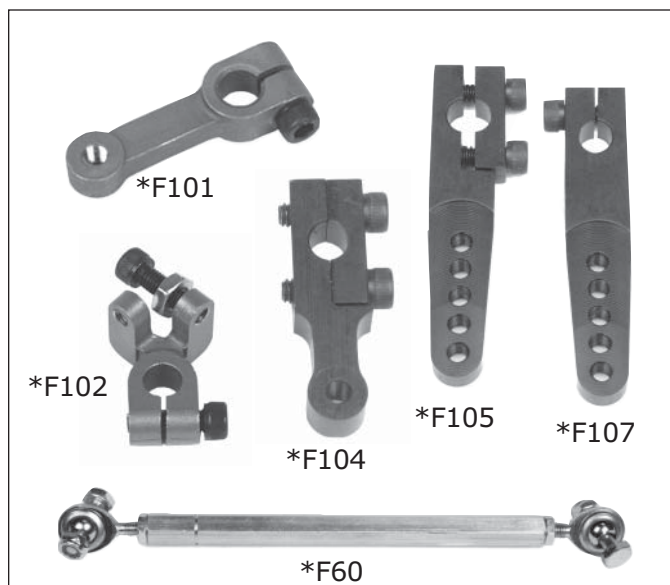
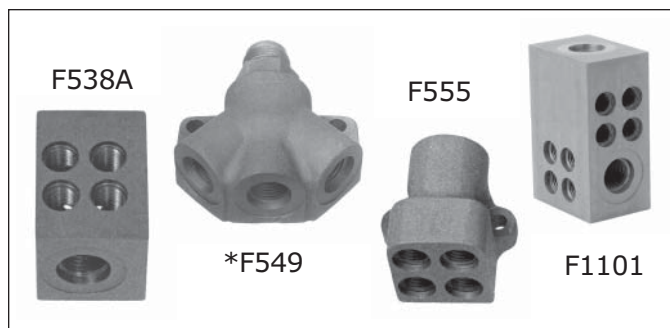

BUTTERFLIES

Part No.

F150	1-7/16" ID throat
F151	1-9/16" ID throat
F152	1-11/16" ID throat
F153	1-13/16" ID throat
F1501	1-15/16" ID throat
F154	2-1/16" ID throat
F155	2" ID throat
F156	2-3/8" ID throat
F157 & F157A	2-3/4" ID throat
F158 & F158A	3" ID throat

F158A-090	3" ID - .090 thick
F159 & F159A	2-7/16" ID throat
F160 & F160A	2-3/16" ID throat
F161 & F161A	2-7/8" ID .064 thick
F161A-090	2-7/8" ID .090 thick
F162 & F162A	2-5/8" ID throat
F163 & F163A	5-1/4" ID throat
F164 & F164A	2-1/2" ID throat
F166	2-13/16" ID throat
F167	2.300" ID throat
F168	4-5/16" ID throat
F169	1.920" ID throat

THROTTLE RETURN SPRINGS

Fits SB Chevy RAW Power or Mega Power Fuel Injectors with provisions for springs. Use on other models requires modification of casting.

Part No.

*F1121	Throttle Return Spring, LH
*F1122	Throttle Return Spring, RH

PINCH CLAMP REPLACEMENT

Part No.

*PC/327C8	(Fits Mega Power Injector. Specify bore size of fuel injector)
*PC/327C8A	(RAW Power 2-3/16" bore)
*PC/327C8B	(RAW Power 2-7/16" or 2-1/2")

O-RINGS, SEALS, WASHERS, GASKETS

Part No.

2-11	O-Ring
4-10	By-Pass Seal
F580	Double Gasket
F31L	Butterfly Lockwasher
F33L	Ram Tube Lockwasher
F33F	Nozzle Cap Gasket
F34	Pinch Clamp Washer

SCREWS & CAPS

Part No.

F1-1x5	Butterfly Screw (5/16" shaft)
F1-1x6	Butterfly Screw (3/8" shaft)
F1-3Ax8	Ram Tube Screw
F3-3x3B	Brass Nozzle Cap
F3-4Ax12	Pinch Clamp Screw



Throttle Return Springs



Pinch Clamp Replacement

