

Hellwig PRODUCTS

INSTALLATION INSTRUCTIONS

Front Stabilizer Bar 7867

1966-77 Ford Bronco

Thank you for purchasing a quality Hellwig Product.

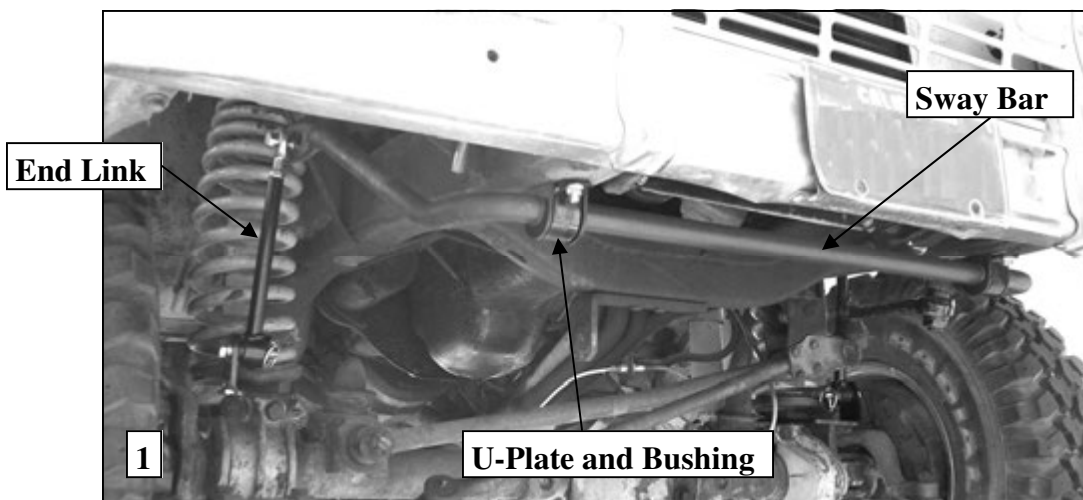

TORQUE TABLE

Bolt Size 3/8"— 35 ft lbs * Bolt Size 7/16"— 45 ft lbs* Bolt Size 1/2"—75 ft lbs *Bolt Size 9/16"— 90 ft lbs

SAFETY: BEFORE BEGINNING INSTALLATION BE SURE TO SET THE PARKING BRAKE AND CHOCK THE WHEELS.

NOTE: TO EASE INSTALLATION AND PROPERLY ADJUST THE BAR, THE WEIGHT OF THE VEHICLE MUST BE ON THE SUSPENSION AS IF DRIVING DOWN THE ROAD. DO NOT RAISE THE VEHICLE BY THE FRAME (Other than to remove the coil spring).

NOTE: THIS KIT REQUIRES DRILLING THE FRAME RAIL AND POSSIBLE RELOCATION OF FUEL AND BRAKE LINES. INSTALLER MUST ENSURE THAT THE SWAY BAR KIT WILL NOT INTERFERE WITH ANY FUEL OR BRAKE LINES OR HOSES.

Hellwig PRODUCTS

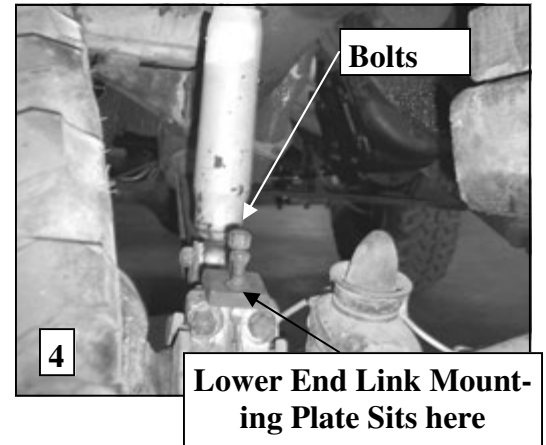
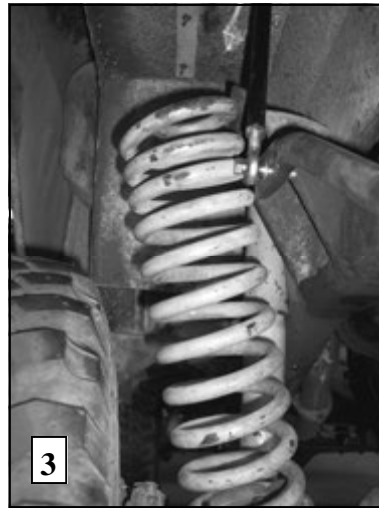
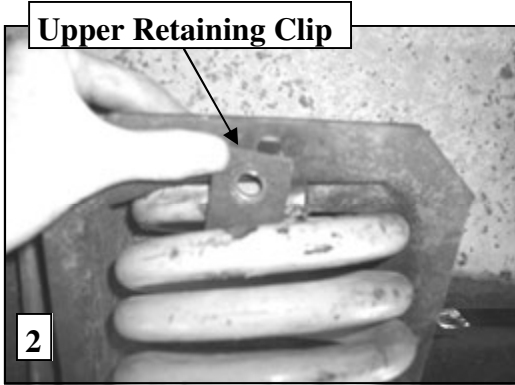

1. With the vehicle sitting on the ground, remove the upper retaining clip from your coil spring by removing the two bolts. See PHOTO 2.
2. Jack the vehicle up by the frame until the wheel is at full droop, **support the frame with jack stands**, pry the top of the coil out of the upper coil bucket. See PHOTO 3.
3. Remove the two bolts holding the coil between the lower retaining plate and the radius arm. Remove the entire coil from the vehicle. See PHOTO 4.
4. Place the lower end link plate on the top of the radius arm with end link tab outboard. Line up the two holes. Reattach the coil following the previous instructions in reverse with the lower end link mounting plate sandwiched between the coil bucket and the radius arm. We have included longer radius arm bolts and washers to compensate for the additional width of the mounting plate. See PHOTO 9
5. Remove the jack stands and lower the vehicle back on its on weight and then repeat the previous steps to install the lower end link mounting bracket on the other side of the vehicle.
6. Lubricate the inside diameter of the D-Bushings and place them onto the straight area of the bar as shown in PHOTO 7. Install U-plates on D-bushings.
7. On the underside of the frame towards the bumper, mark holes for U-Plates. The hole will be approximately 2.68" forward of the center of the oval hole already in the frame. Use threaded plate as a guide for hole spacing. Check clearance of threaded plate to inner frame before drilling holes.

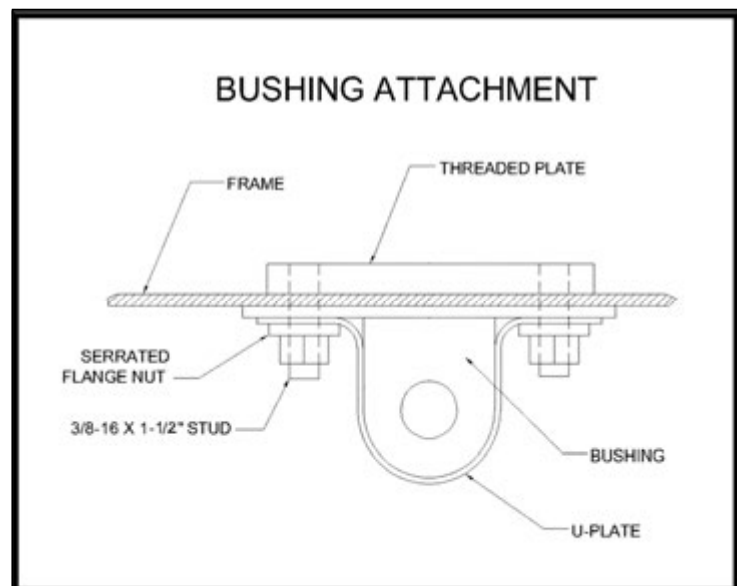
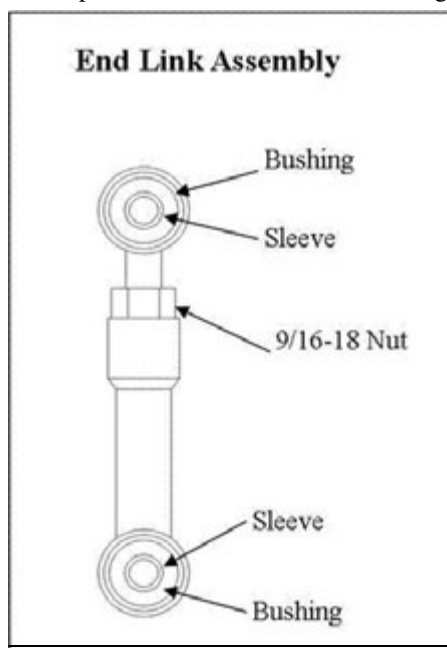

Hellwig PRODUCTS

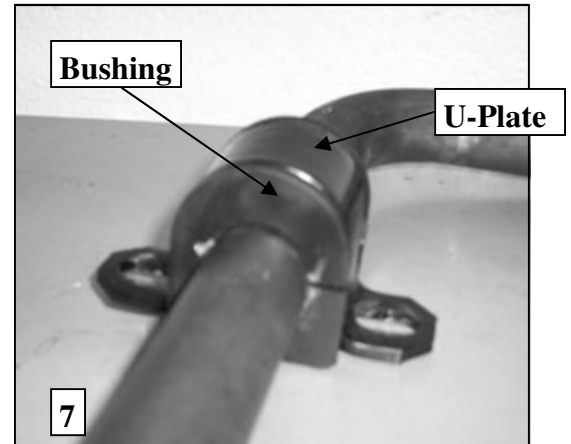
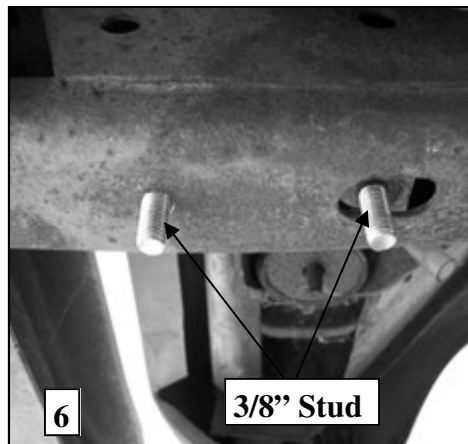
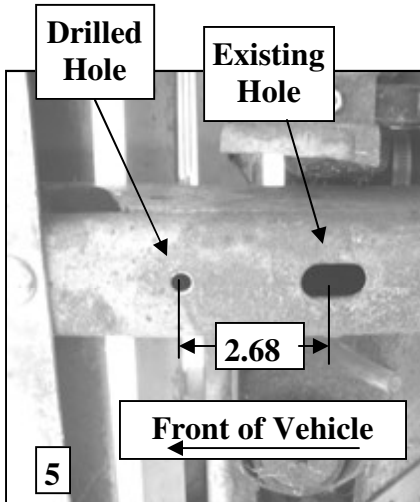

8. Drill a 7/16" hole on both frame rails. See PHOTO 5.
9. Attach U-plates to frame rail with 3/8-16 X 1-1/2" studs and flange nuts as shown in the diagram on Page 2. Leave loose for adjustment later. See PHOTOS 6 & 8.
10. **Fully lubricate bushings before installation.** Press hourglass bushing into both end link loops. Thread the 9/16" jam nut onto the male part of the end link and then thread the end links together following the diagram on page 2.
11. Attach end links to the center hole of the sway bar and change end link length so the three end link holes are parallel to the ground. **IMPORTANT NOTE – Center hole position is only for determining hole location. The end link will be moved to the outer hole prior to initial use.**
12. Using the 7/16 bolt, attach the end link to the lower end link mounting plate. See PHOTO 9.
13. Align sway bar and end links and tighten 3/8" u-plate mounting bolts to 25 ft-lb. The bar should be offset to the driver side to maximize clearance between the sway bar and the steering box/pitman arm.
14. Place collar clamps on sway bar inside of the D bushings on the bar to keep the sway bar aligned during use. Torque bolts on collar clamps to 5-8 ft-lb..
15. **Bounce the vehicle checking for clearance on all under carriage components: fuel tank, shocks, differential, brake and fuel lines, etc.** Test drive the vehicle and recheck all clearances and the installation alignment. Adjust as needed. Re-check your installation after one week of driving and periodically on a regular basis.
16. **The sway bars arms have three mounting holes. Mounting the sway bar on the outer hole (rear-most) is the nominal position. For a firmer setting, use the inner holes. We recommend starting with the outer mounting hole until you are accustomed to the vehicle's new handling characteristics. Select the mounting point that best fits your driving style.**

