

# Hellwig PRODUCTS

## INSTALLATION INSTRUCTIONS

### Rear Stabilizer Bar

### 2005+ Nissan Frontier

Thank you for purchasing a quality Hellwig Product.

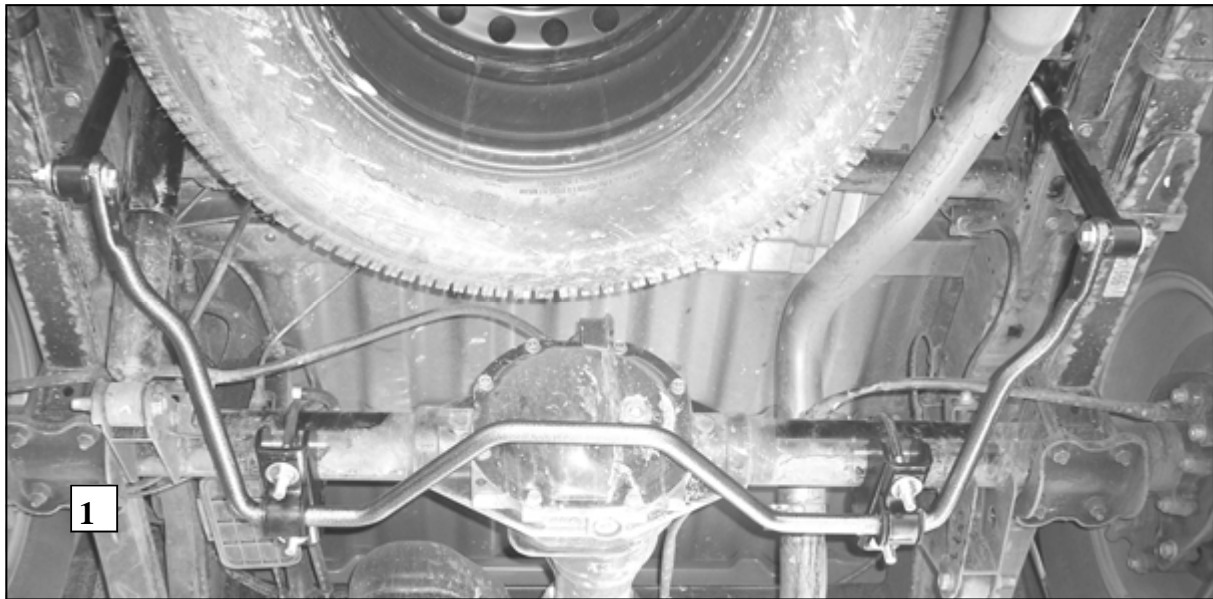

### END LINK MOUNTING DETAIL

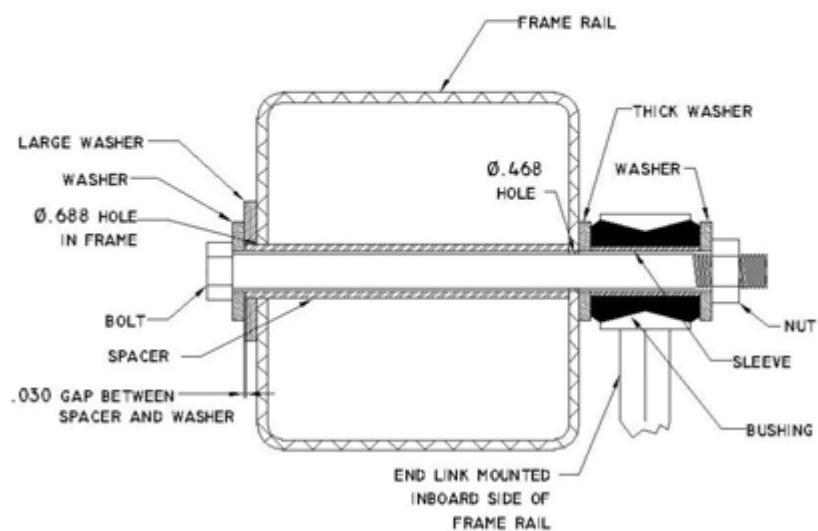

# Hellwig PRODUCTS

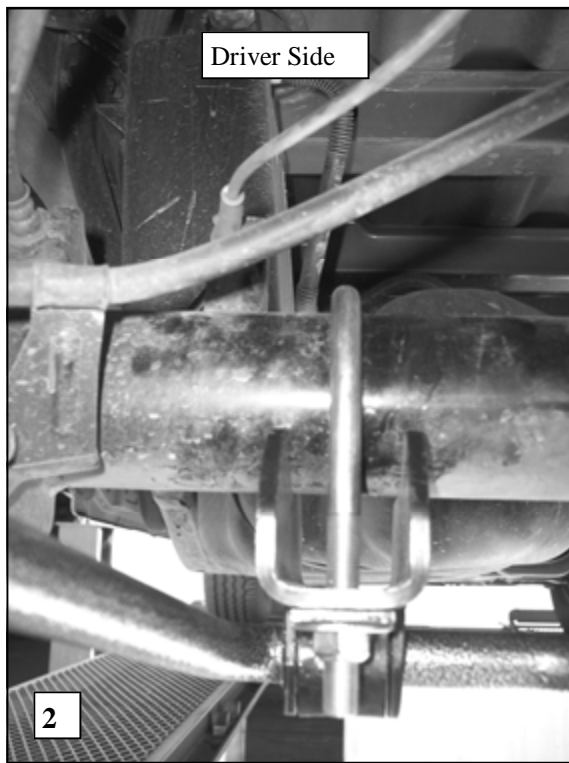

## TORQUE TABLE

**BOLT SIZE:** 3/8" = 20-30 ft. lbs. - 7/16" = 35-45 ft. lbs. - 1/2" = 50-70 ft. lbs. - 9/16" = 70-90 ft. lbs.

**SAFETY: BEFORE STARTING YOUR INSTALLATION, BE SURE TO SET PARKING BRAKE AND CHOCK TIRES.**

**NOTE: TO EASE INSTALLATION AND TO PROPERLY ADJUST BAR, THE WEIGHT OF THE VEHICLE MUST BE ON THE SUSPENSION, AS IF DRIVING DOWN THE ROAD. DO NOT RAISE VEHICLE BY FRAME.**

**NOTE: THIS KIT INCLUDES LOCK NUTS WHICH REQUIRE TIGHTENING WITH A WRENCH AFTER BEING STARTED BY HAND.**

1. Place the U-bolts over the axle tubes as shown in photos 2 & 3. Be careful to place the U-bolts under any brake lines or wires so not to damage them when the U-bolts are tightened.
2. Lubricate the D-shaped bushings and place them on the flat areas of the bar to line up with the U-bolts. Place the U-plates over the D bushings.
3. Place the saddle brackets onto the U-Bolts on the axle tubes. Place the U-Plates over the D shaped bushings on the bar and attach the bar to the U-Bolts and saddle brackets with the flat washers and 1/2" locknuts provided. LEAVE LOOSE AT THIS TIME to allow for adjustment later.
4. Position sway bar on axle so that it clears all chassis components including fuel tanks, brake lines, fuel lines, etc.

# Hellwig PRODUCTS

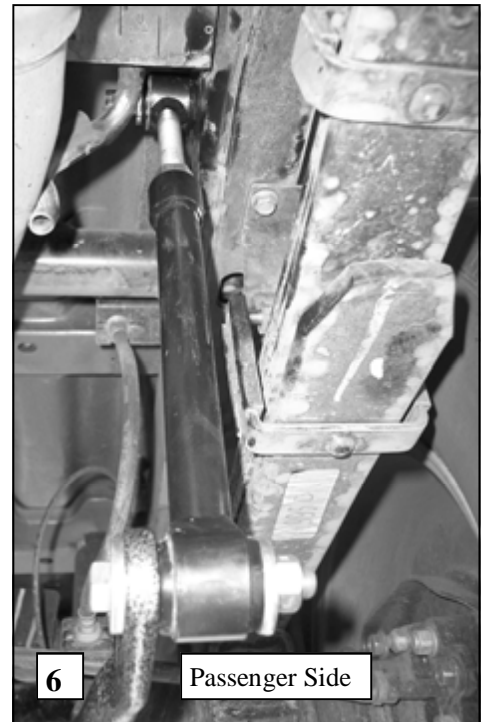
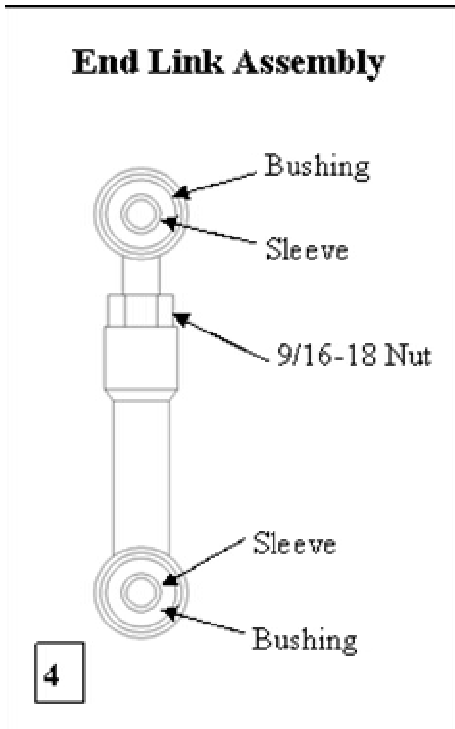

5. Assemble end link assembly by inserting hourglass bushings into loops in end links first. Then insert sleeves into bushings. Lubricate bushings and sleeves with supplied grease before assembly.
6. Attach end links to the outer hole of the sway bar and align end links for best fit as shown in PHOTO 4.
7. Attach end link to outermost hole in sway bar using 7/16 X 2-3/4 bolt, thick washers and locknut as shown in photos 1 & 7. Torque bolt to 40 ft-lb.
8. Align end links for best fit as shown in PHOTOS 1,5,6,&7. Note that a 3/4" spacer is used on the driver side only as shown in PHOTO 5. When satisfied with their location, mark location of holes for the end links as shown in PHOTOS 8 & 9.
9. Transfer hole location to outer edge of subframe rail. A piece of cardboard can be used by marking the location of the hole on the cardboard and transferring the location to the outer rail. Drawing a line on the subframe square to the subframe rails will keep the hole location square. See PHOTOS 8&9.
10. **Review end link mounting detail before drilling holes. BEFORE DRILLING ANY HOLES IN THE RAIL—RELOCATE AND PROTECT ANY FUEL OR BRAKE LINES THAT MAY INTERFERE WITH THE DRILL BIT OR SWAY BAR INSTALLATION.**

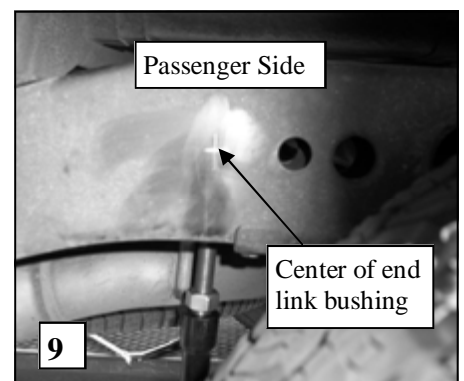
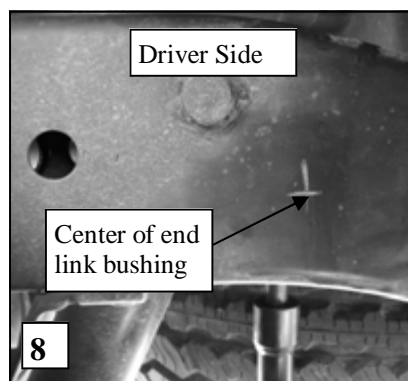
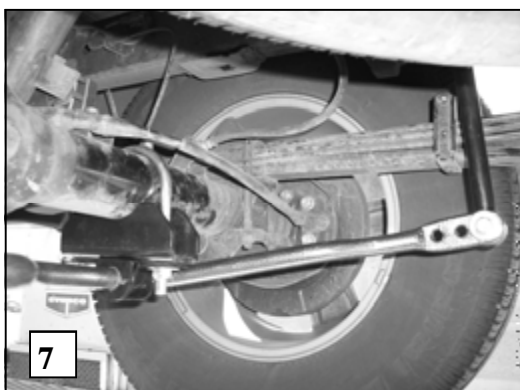

# Hellwig PRODUCTS

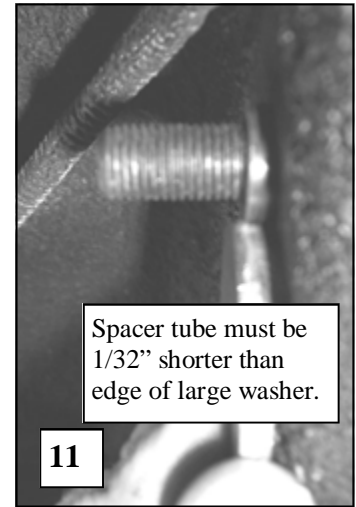
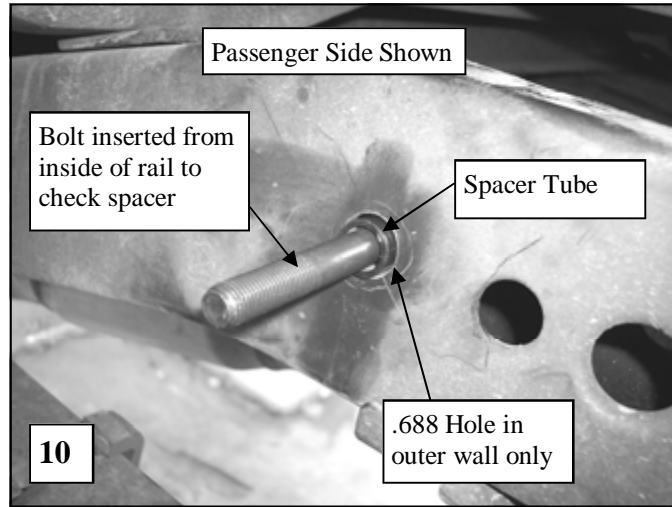
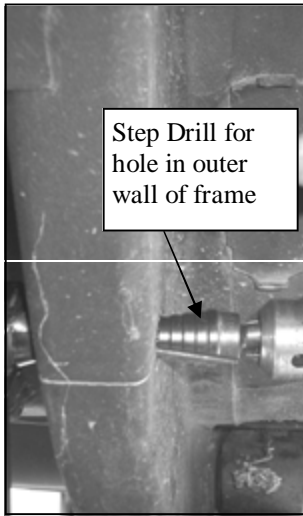

11. Drill a 15/32 (.468) hole through **BOTH** walls of the frame. Make sure holes are square to one another when drilling holes. It is easiest to drill through the outer wall first and use a transfer punch to mark location on inner wall of frame.
12. Drill an 11/16 (.688) hole through **OUTER** wall of frame **ONLY**. See photo 7. A step drill works well for this application. Do not use a hole saw as the hole must be a close fit to the spacer tube.
13. Insert 7/16 X 6" bolt through driver's side rail as shown in PHOTO 9 with head on inside of frame rail. Insert 7/16 X 5" bolt in same manner through passenger side rail.
14. For severe duty it is recommended that the spacer tube be welded to the outer frame wall. If the spacer is to be welded, review severe service end link detail for your frame rail and skip to line 17. **IMPORTANT—If any welding is to be done, the installer must ensure that all hazards (fuel, electrical, etc) are eliminated and that fuel tanks, fuel lines, brake lines, wiring, etc. are not affected by the welding operation.**
15. Insert spacer tube from outside of rail until it contacts inner wall of frame rail and check fit. The spacer tube must be 1/32" (.030") shorter than edge of large washer as shown in PHOTO 11. **Failure to do this will result in insufficient preload and noise. Cut, file or grind end of spacer tube to achieve proper length.**
16. Remove bolt and spacer from inside of frame rail.
17. Attach end links to frame rail as shown in detail and PHOTOS 5&6. Note that a 3/4" spacer is used on the driver side rail only.
18. Torque end link bolts to 40 ft-lb.
19. Torque axle U-bolts to 60 ft-lb.
20. Tighten jam nut on adjustable end links.
21. **Bounce the vehicle checking for clearance on all under carriage components: fuel tank, shocks, exhaust, differential, brake and fuel lines, etc.** Test drive the vehicle and recheck all clearances and the installation alignment. Adjust as needed. Re-check your installation after one week of driving and periodically on a regular basis.

22. The sway bar has three end link mounting holes. The end link **MUST** be mounted on the outer hole for initial use. SEE PHOTO 7. For a firmer setting, use the inner holes. You must use the outer mounting hole as shown in photo 7 until you are accustomed to the vehicles new handling characteristics. After driving vehicle, a firmer setting may be selected if desired. It is recommended that the outer hole be used for street driving.

## END LINK MOUNTING DETAIL SEVERE SERVICE

