

Hellwig PRODUCTS

INSTALLATION INSTRUCTIONS

Thank you for purchasing a quality Hellwig Product.

PLEASE READ THIS INSTRUCTION SHEET COMPLETELY BEFORE STARTING YOUR INSTALLATION

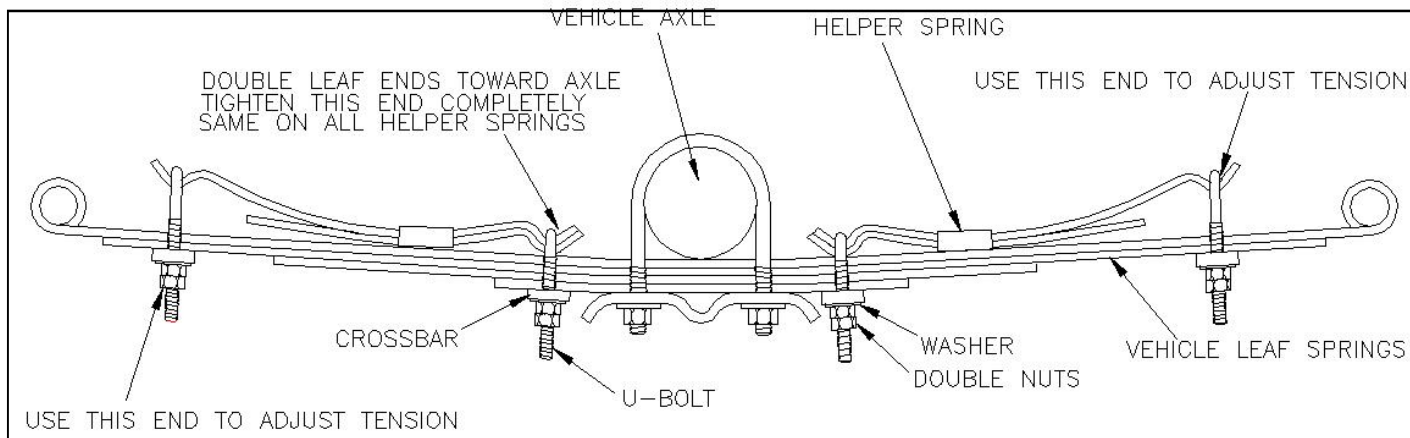

TORQUE TABLE

BOLT SIZE: 3/8" = 20-30 ft. lbs. - 7/16" = 35-45 ft. lbs. - 1/2" = 50-70 ft. lbs. - 9/16" = 70-90 ft. lbs.

SAFETY: BEFORE STARTING YOUR INSTALLATION, BE SURE TO SET PARKING BRAKE AND CHOCK TIRES.

IMPORTANT NOTE: HELLWIG HELPER SPRINGS ARE DESIGNED TO INCREASE THE "LEVEL LOAD" CARRYING CAPACITY OF YOUR VEHICLE. NEVER LOAD THE VEHICLE THAT THIS UNIT IS BEING INSTALLED ON BEYOND THE MANUFACTURER'S MAXIMUM GROSS VEHICLE WEIGHT RATING.

NOTE: DO NOT, ATTEMPT TO INSTALL THIS UNIT ON CHEVY/GMC ASTRO VANS OR ANY OTHER VEHICLE WITH PLASTIC COMPOSITE SPRINGS.

NOTE: IF YOUR VEHICLE IS EQUIPPED WITH A BRAKE PROPORTIONING VALVE ON THE REAR AXLE READ INSERT (R-362)

NOTE: Your spring may have a small hole in the end, this is for our manufacturing process and will not be used.

1. Be sure the vehicle is on flat hard surface, use tire blocks and safety stands. Raise up the vehicle by the frame so that the tires are just contacting the floor.
2. Place the accessory spring on top of the springs as per drawing.
NOTE: The short assembly will mount in front and the long assembly will mount on the rear of vehicle's springs.
Place the leaves as close as possible to the axle without making contact.
3. Install the U-bolts on the accessory springs using the crossbars, washers and nuts which are provided. Tighten the U-bolts closest to the axle completely. **Double nut this U-bolt.**
4. Install the crossbar, washer and nuts on the end U-bolt. Tighten until enough threads show through to install the locknut.
5. To adjust the spring for more load capacity remove the lock nut from the end U-bolt and draw the U-bolt tighter. **Be sure to double nut after each adjustment that is made.**
6. Bounce the vehicle and check for clearance on all undercarriage components. Check to see that all wiring, brake and fuel lines are free and clear of your installation.
7. Recheck your installation. Are all lock nuts installed? Are the U-bolts closest to the axle drawn down completely tight. After one week of driving check your installation to see that it is properly tight and has not shifted. Recheck on a monthly regular basis thereafter.