

HELLWIG PRODUCTS

INSTALLATION INSTRUCTIONS

Frame Reinforcement Kit 11100 (Patent Pending)

1968-72 GM A-Body Coupe/2dr Sedan

Read Instructions FULLY before starting Installation

Important Note

Installation of this kit requires welding and fabrication skills. If, you do not feel that you have adequate skills to install this kit, seek a professional installer.

Tools Required:

Welder capable of fully welding 10 GA .135" steel

Grinder with the following:

Grinding Disc

Cutoff Wheel

60 Grit Flap disk—optional— for finishing and close fitment

C-Clamp

2-3 lb. Hammer to straighten flanges of rail (if required)

Floor Jack

Wood 4x6 blocks to raise body off of frame

New body bushings — Optional but **Highly Recommended** Energy Suspension p/n 3-4170G has been used with great success on our installations

Optional—5 feet of 2" square tubing or angle to brace frame rail in center to keep frame within factory specification.



BEFORE STARTING YOUR PROJECT

DISCONNECT AND REMOVE BATTERY FROM VEHICLE

WHEN LIFTING A VEHICLE WITH A JACK, BE SURE TO USE SAFETY STANDS.

WHEN LIFTING BODY OFF THE FRAME MAKE SURE VEHICLE AND FRAME ARE SUPPORTED SO THAT OPERATION CAN BE COMPLETED SAFELY.

WHEN BODY IS REMOVED FROM FRAME, SUPPORT BODY SO THAT IT IS SECURE AND SOLIDLY SUPPORTED.

THE A-BODY BODY SHELL IS HEAVIER AT THE REAR AND THIS FACT WILL NEED TO BE COMPENSATED FOR WHEN LIFTING BODY OFF FRAME.

ENSURE THAT THE INSTALLATION OF COMPONENTS WILL NOT CRUSH OR DAMAGE FUEL AND BRAKE LINES OR ELECTRICAL HARNESSSES.

BEFORE DRILLING ANY HOLES, ENSURE THAT ALL ELECTRICAL WIRES, FUEL LINES, BRAKE LINES, BRAKE HOSES AND ANY OTHER COMPONENTS ARE MOVED OR PROTECTED TO AVOID DAMAGE FROM DRILLING ANY HOLES .

DO NOT ATTEMPT ANY MODIFICATIONS TO THE VEHICLE OTHER THAN THOSE OUTLINED IN THIS INSTRUCTION SHEET. IF ANY INTERFERENCE WITH THE GAS TANK, FUEL LINES, BRAKE LINES, EXHAUST PIPE, ETC. EXISTS, STOP YOUR INSTALLATION AND CALL HELLWIG PRODUCTS FOR TECHNICAL HELP.

THE BRAKE LINES WILL HAVE TO BE RELOCATED TO OUTSIDE THE NEWLY BOXED FRAME FROM INSIDE THE C-CHANNEL

Hellwig PRODUCTS

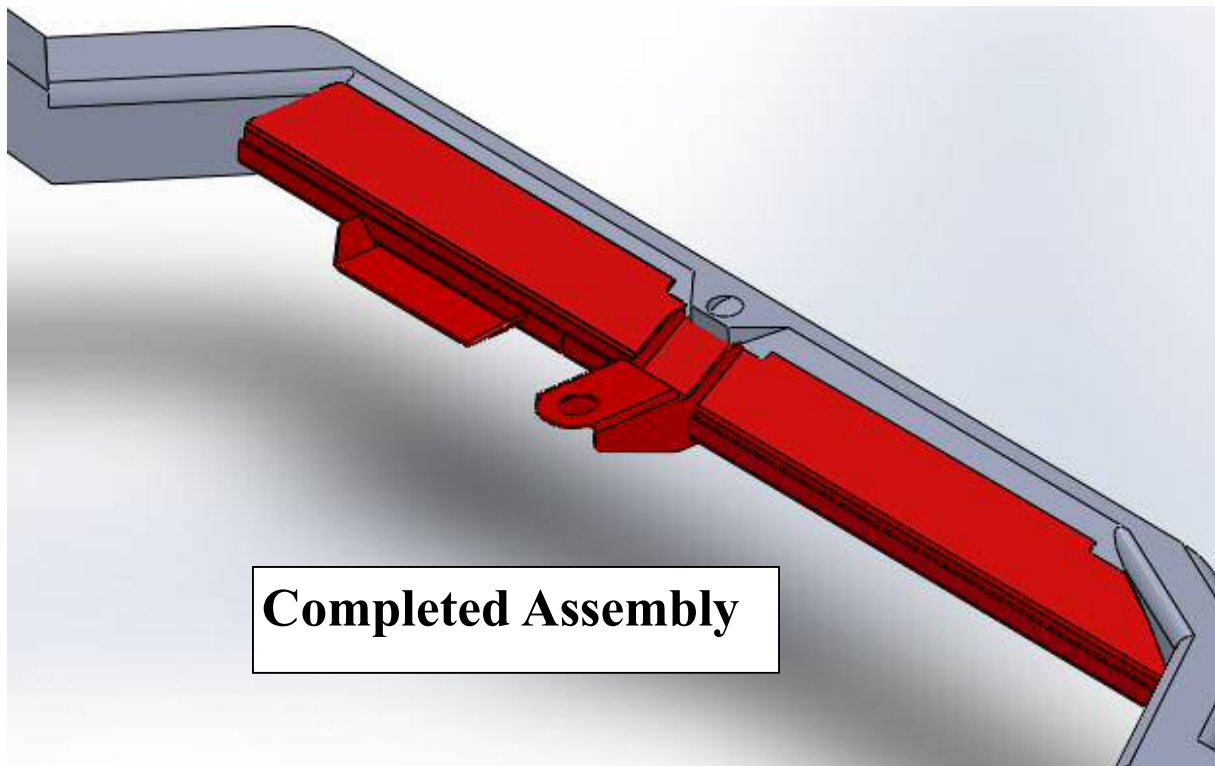
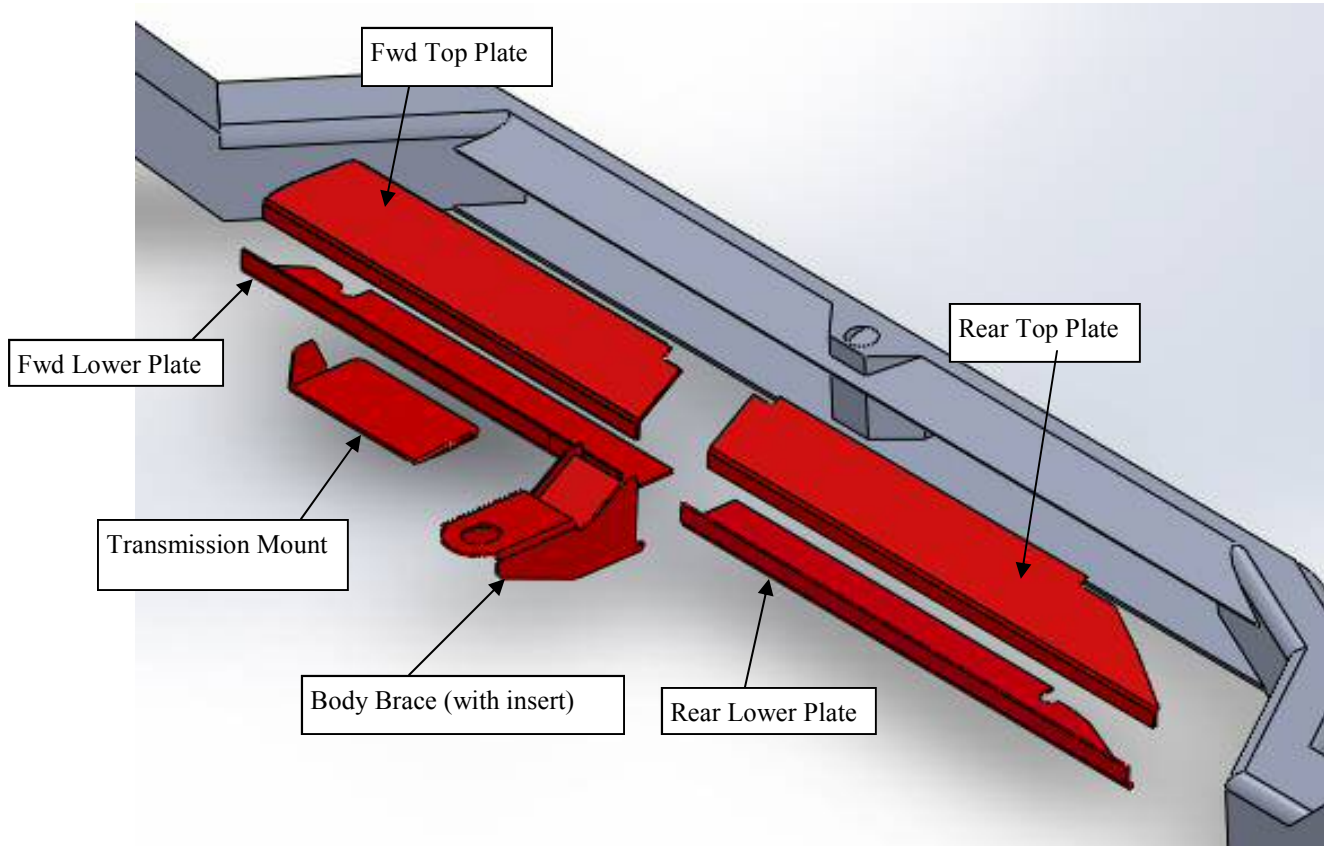

1. Jack up vehicle and place securely on jack stands. Remove wheels and tires.
2. If vehicle is assembled, disconnect and remove battery, remove front and rear bumpers.
Remove fuel tank, fuel lines, and brake lines. Disconnect steering linkage from steering column. Disconnect throttle cable.
3. Disconnect emergency brake cable from body.
4. Disconnect engine compartment wiring harness from bulkhead.
5. Disconnect wiring harness from starter
6. Disconnect wiring harness from heater blower motor.
7. Disconnect wiring harness from distributor, alternator and any other engine mounted components.
8. Remove front clip from vehicle by removing bolts as shown in pictures below.

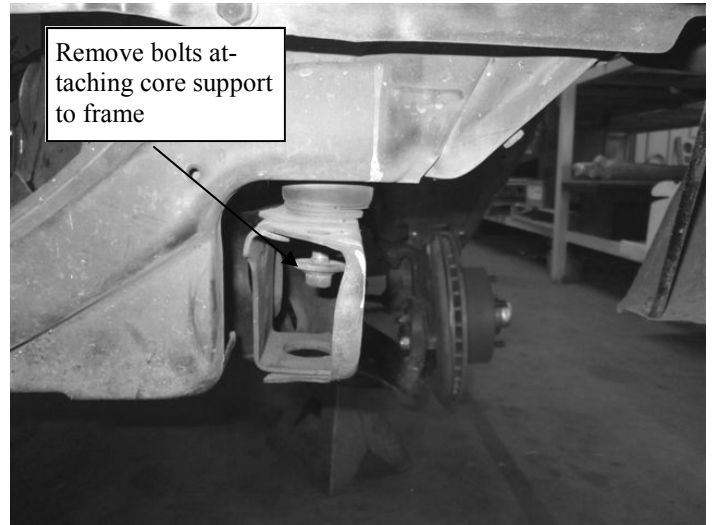
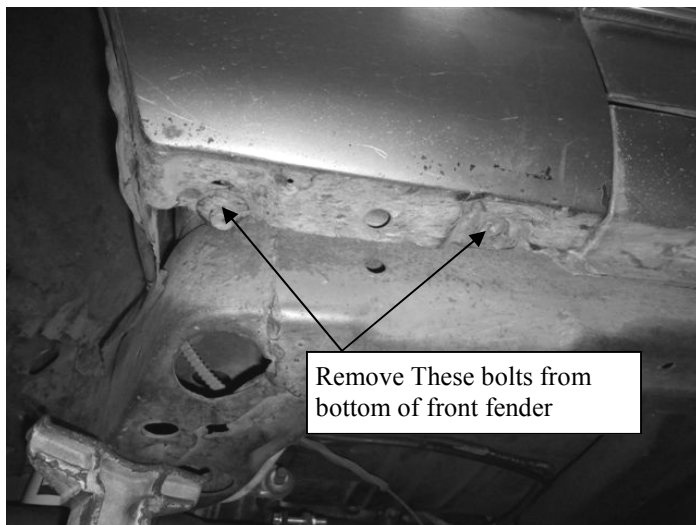
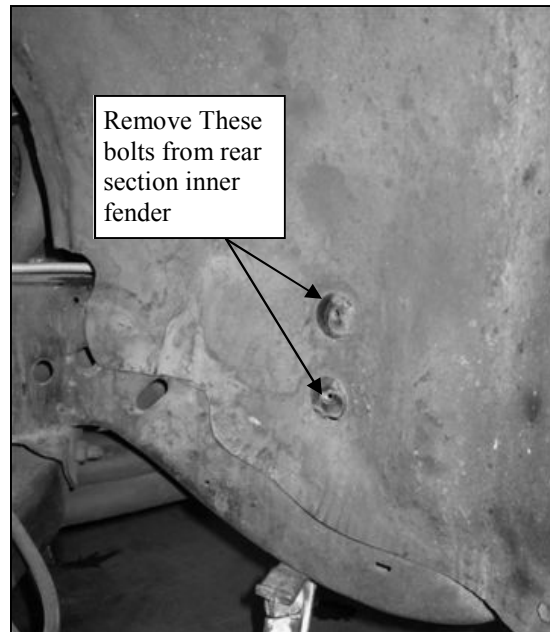
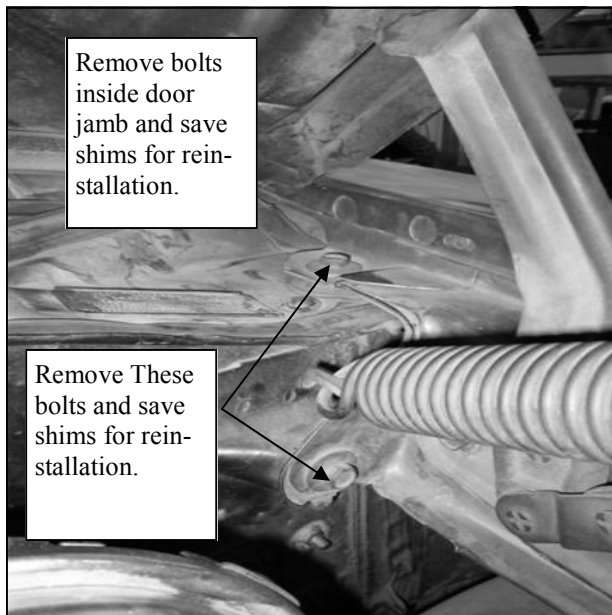

Hellwig PRODUCTS

9. Lift Front Clip off of frame and body.
10. Raise body off frame about 6" and support body so that it is secure.
11. Record measurements as shown below before proceeding with any modification.
These measurements are critical to ensuring that the frame will bolt back on to the body properly. Measurements shown are factory specs. Your frame dimensions will vary slightly. Record these dimensions and check frequently while modifying frame to check if rails are moving from welding heat.

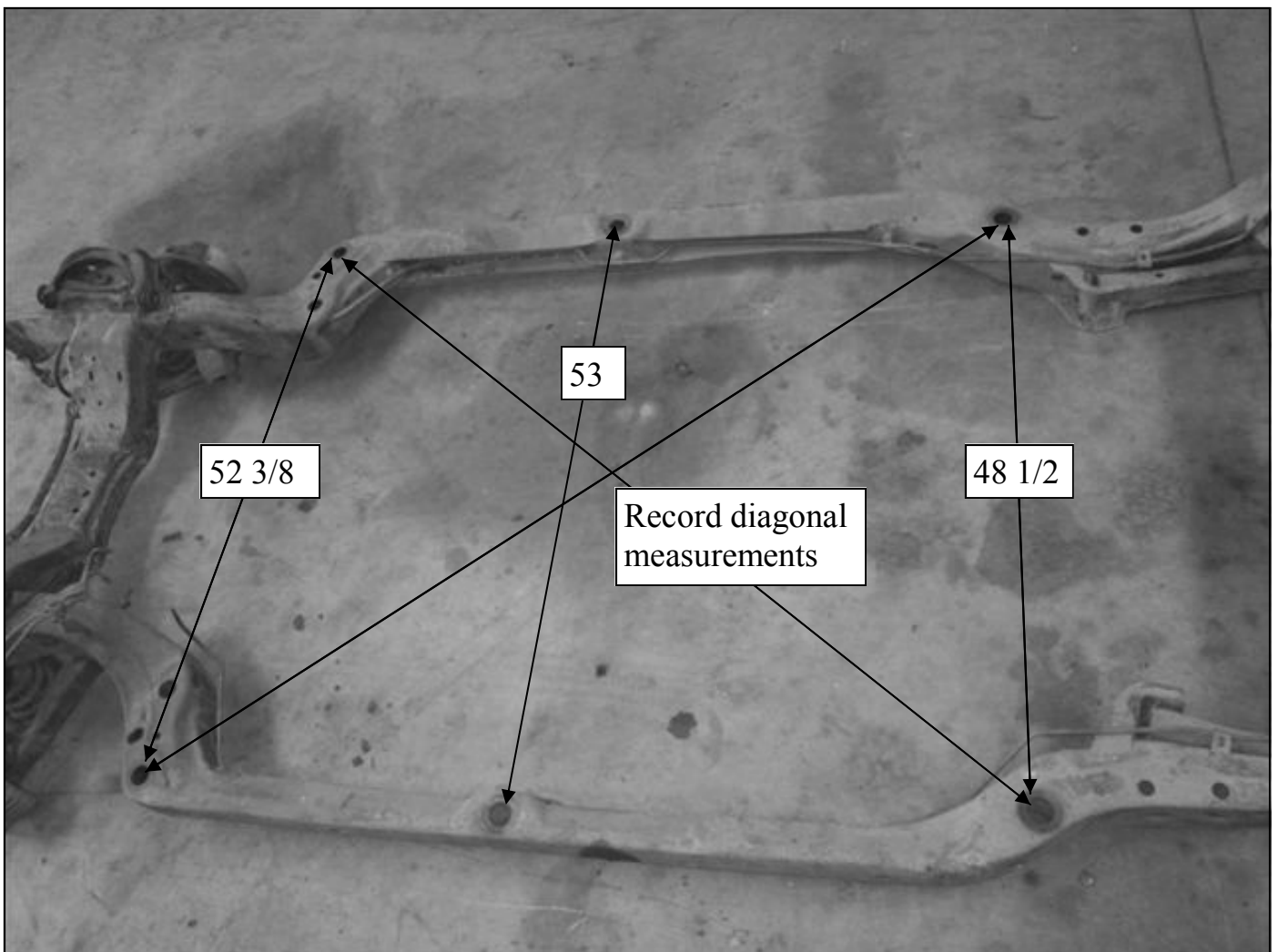

Hellwig PRODUCTS

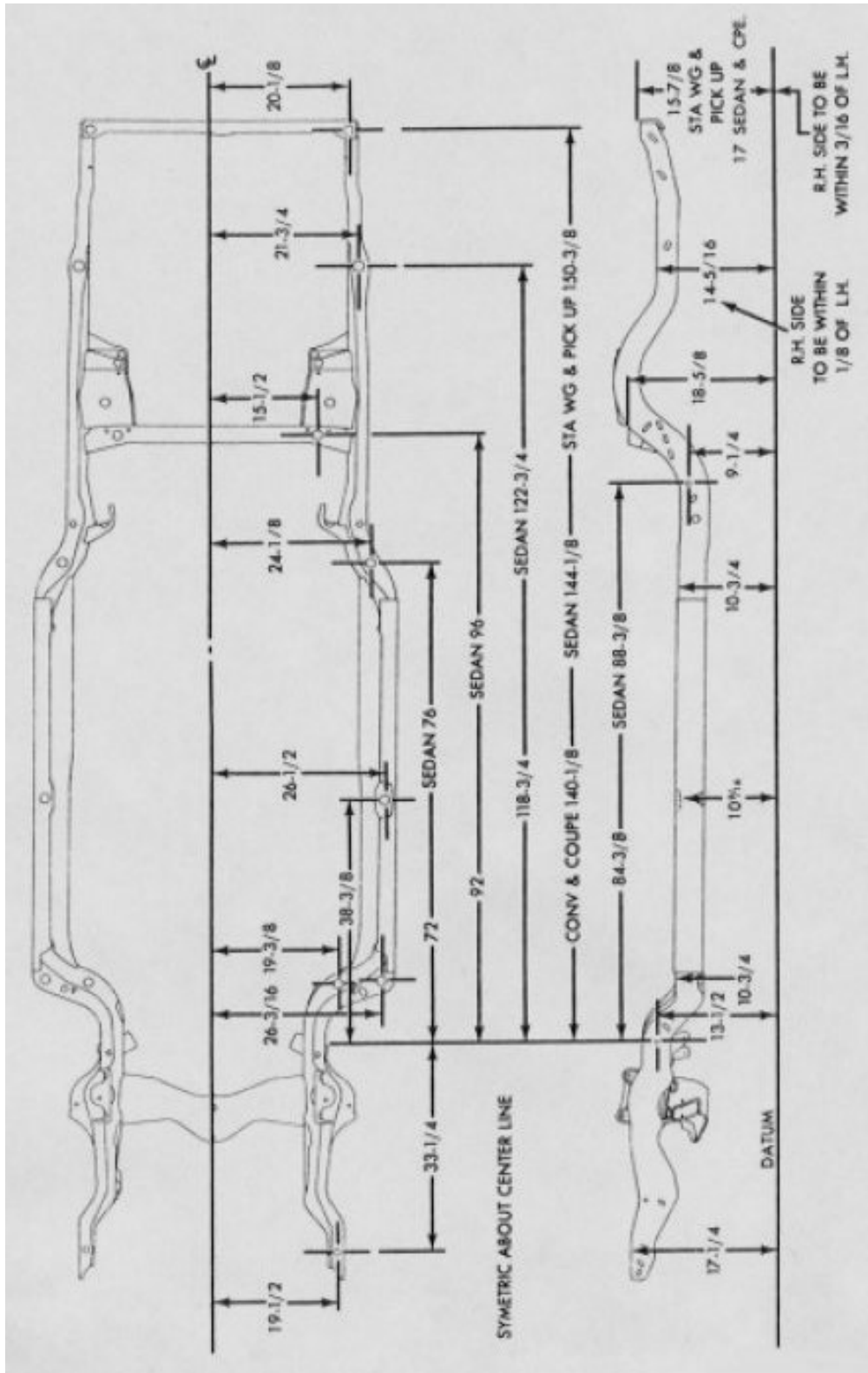

Hellwig PRODUCTS

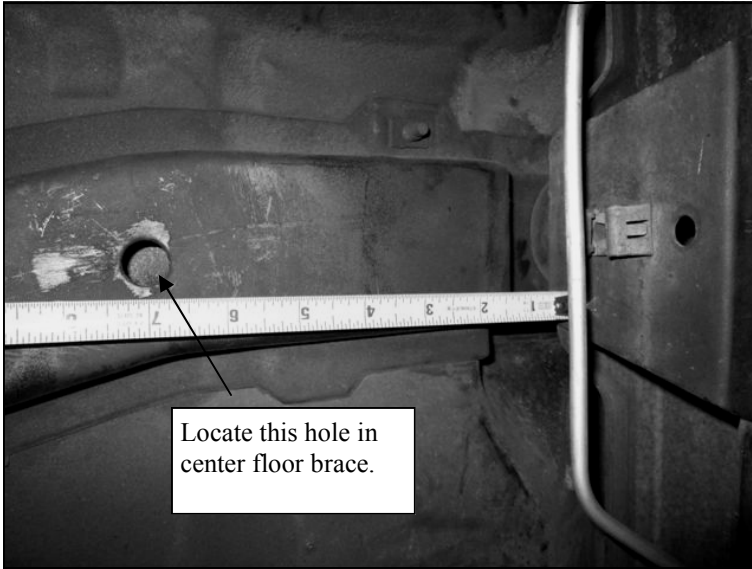

12. Locate hole in center floor support as shown. If hole does not exist skip to step 14 and hole will be added at a later time.

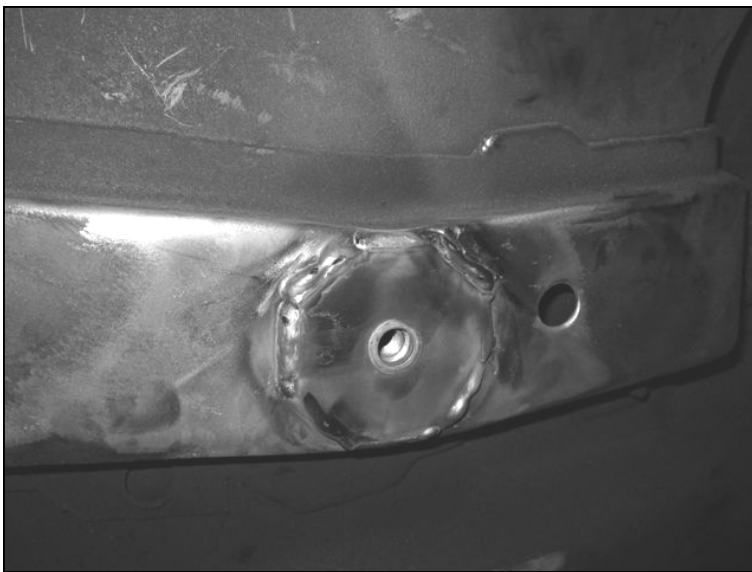

13. Clean floor brace so that clean bare metal is exposed and attach plate with threaded insert to floor brace as shown. The threaded insert will stick up into the floor brace

Hellwig PRODUCTS

14. Raise body off frame about 6" and support body so that it is secure.
15. Remove bracket in center of c channel as shown below

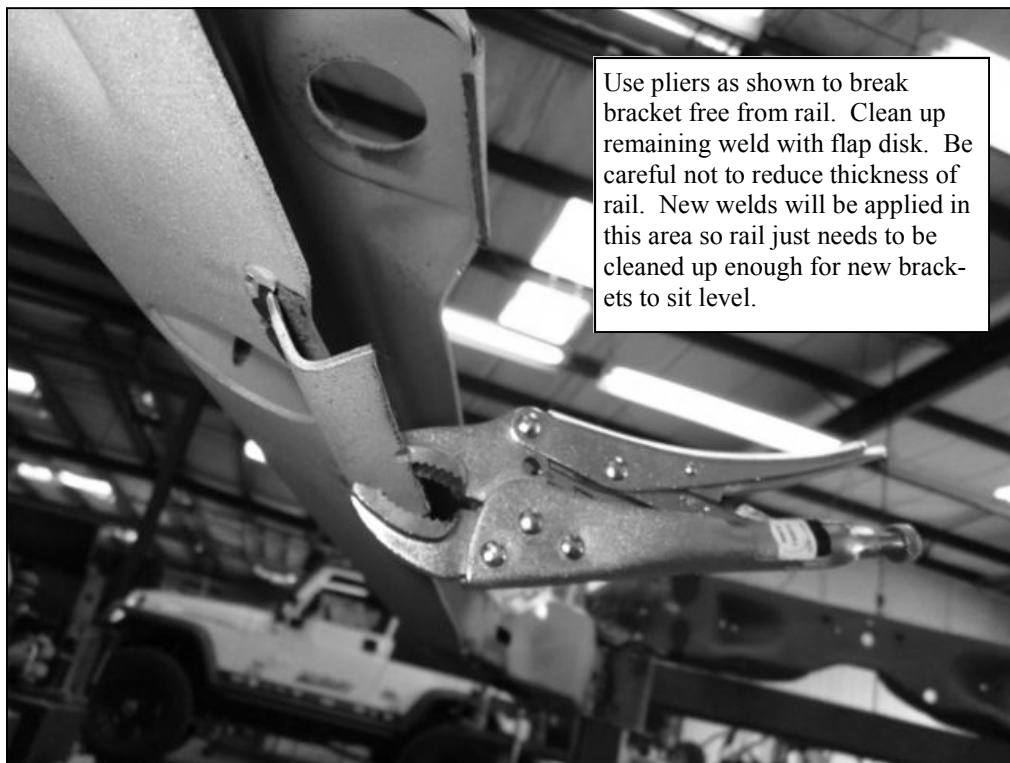
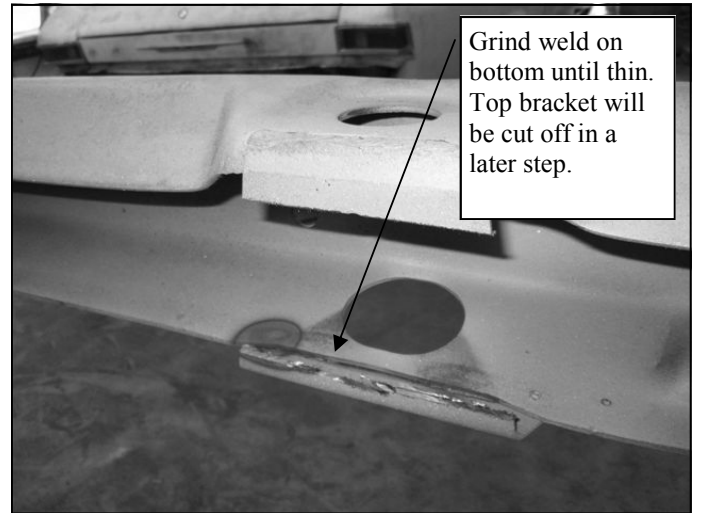
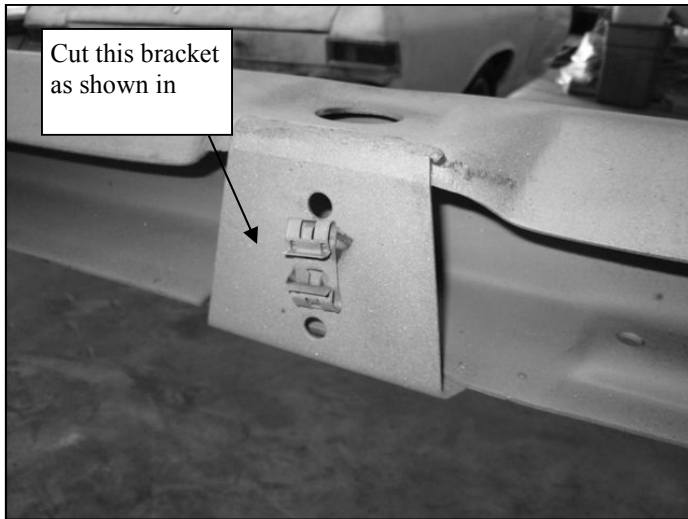

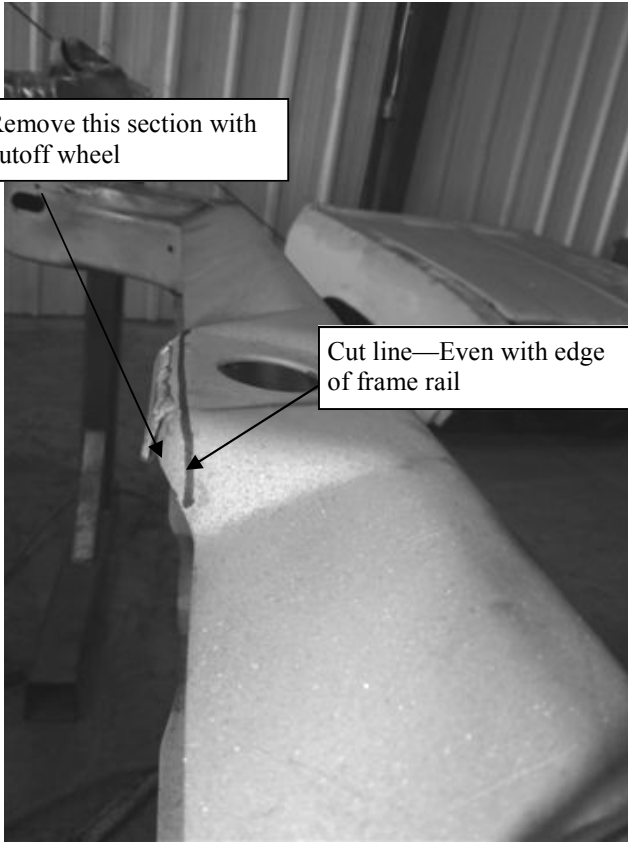

Remove this section with cutoff wheel

Cut line—Even with edge of frame rail

16. Cut section off top of rail at center body mount as shown in picture

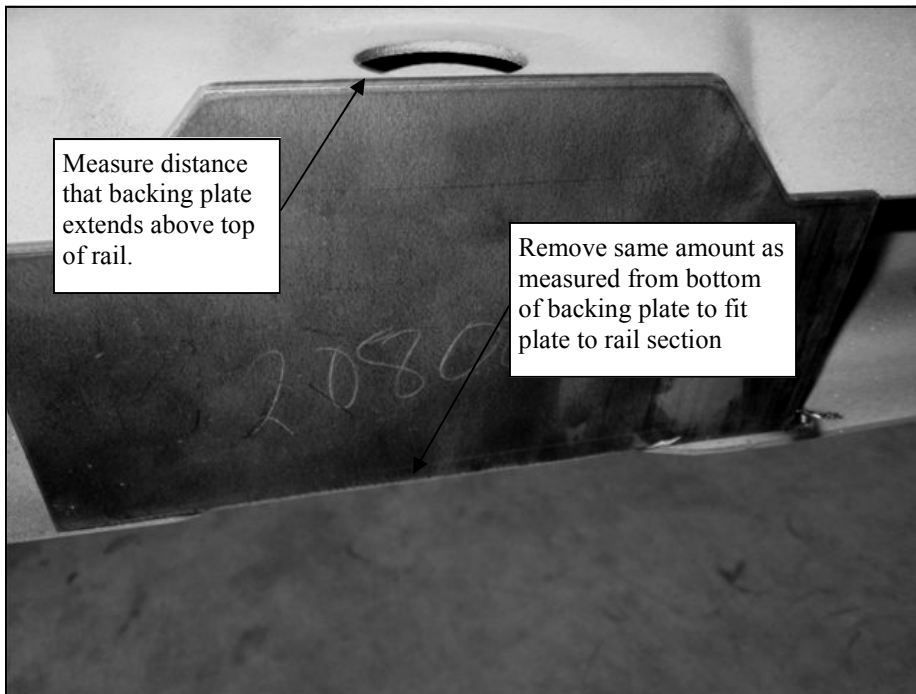

Measure distance that backing plate extends above top of rail.

Remove same amount as measured from bottom of backing plate to fit plate to rail section

17. Place body brace backing plate on rail as shown with bottom of bracket on top of lower frame flange. It will need to be fitted to top section of rail. Measure how high it is above cutoff rail at top and remove this amount from bottom edge of plate.

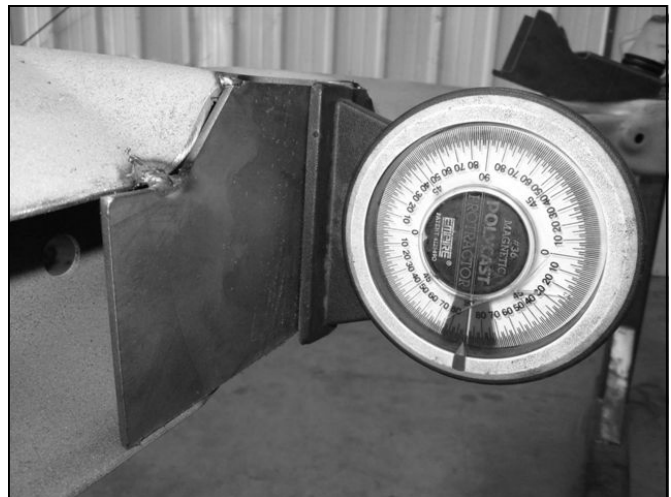

18. Tack backing plate in place as shown with bottom edge of backing plate resting on top of lower rail flange. Make sure that bracket is vertical before proceeding.

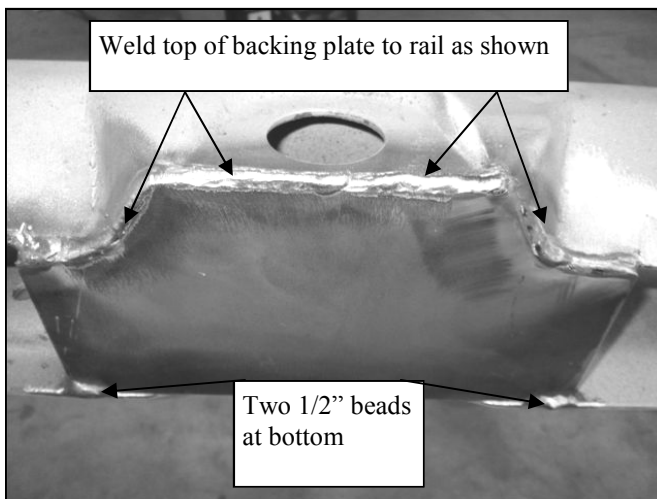

19. Weld backing plate to lower rail flange with two 1/2" long beads at either side. Do NOT add any more weld to bottom of backing plate. Weld top of backing plate as shown to top flange of frame rail. For a cleaner appearance the weld on the top of the backing plate can be ground smooth at this time with a flap disc.

18. Install body mounts on frame rail and lower body back down on top of the body mounts. Square body to rail and attach body to rail with bolts. Fully torque body bolts to ensure that new frame mount is oriented correctly.
19. If vehicle did not have holes in floor brace as shown in step 12 use new body mount brace shown in step 20 to locate hole on floor brace. (do not weld body mount brace at this time) Assemble body bushing to brace using the inner sleeve and hold body mount brace squarely to backing plate tack welded to rail. Mark location on floor brace and make sure it is centered on brace. Check with threaded adapter to verify fit. When satisfied with location of hole, drill a 5/8 inch diameter hole in floor brace and attach threaded insert as shown in step 13. After welding threaded insert to floor brace proceed to step 20.
20. Attach body brace to threaded insert with new body mount, sleeve, washer and 3/8 X 2-1/2" bolt as shown below. Align bracket so that body mount is centered in bracket. Weld bracket to backing plate with 1/2"-3/4" weld ONLY in area shown. Tack tabs at end of bracket to lower flange of frame rail. DO NOT add any more weld than is shown

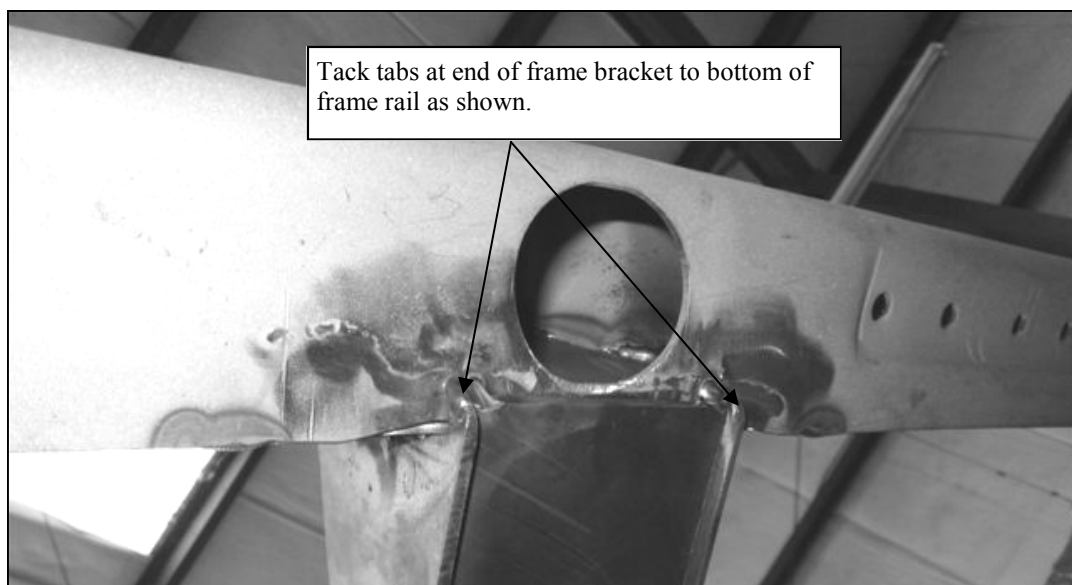
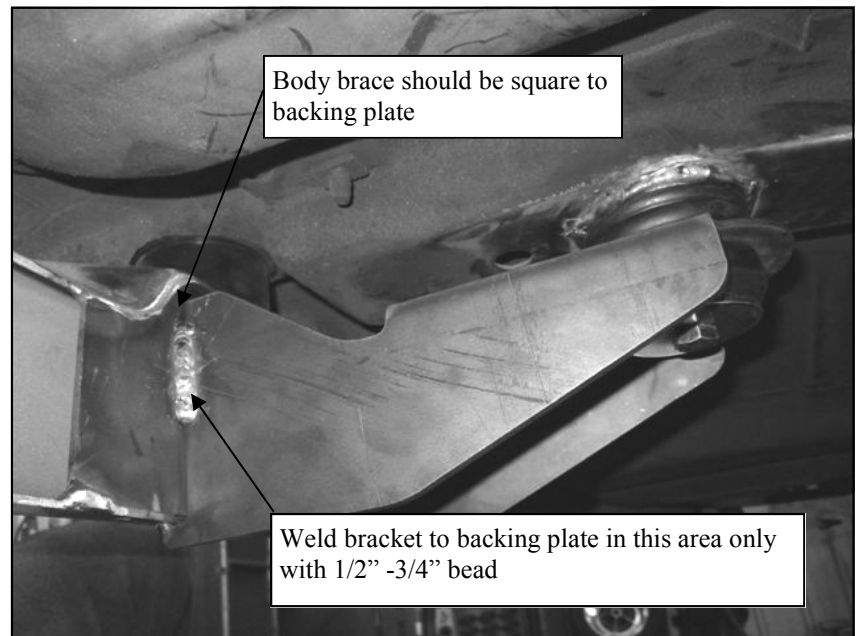
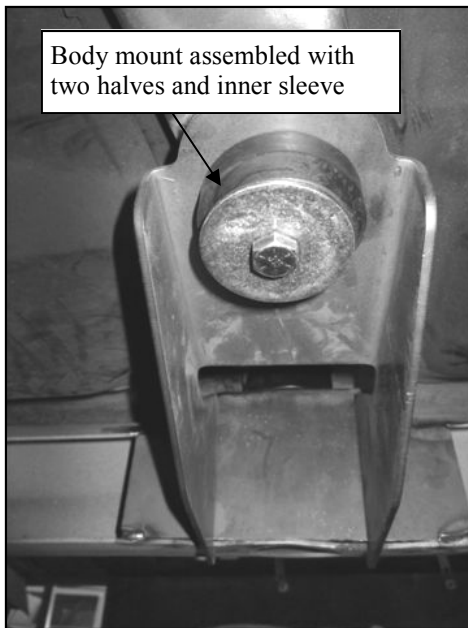

Hellwig PRODUCTS

21. After locating body brace on frame, remove bolts attaching body to frame in all locations and raise body off the frame. If desired, the frame can be removed from under the car at this point to make fitment and welding of the remaining components easier.
22. Insert formed center section into body mount bracket as shown. Tack bottom of center section to bottom of frame first. Align bottom of center section so that it lines up with the ends of the tabs on the body mount brace. After tacking center section in place, align so that it is square with the body brace and tack on top to backing plate as shown.

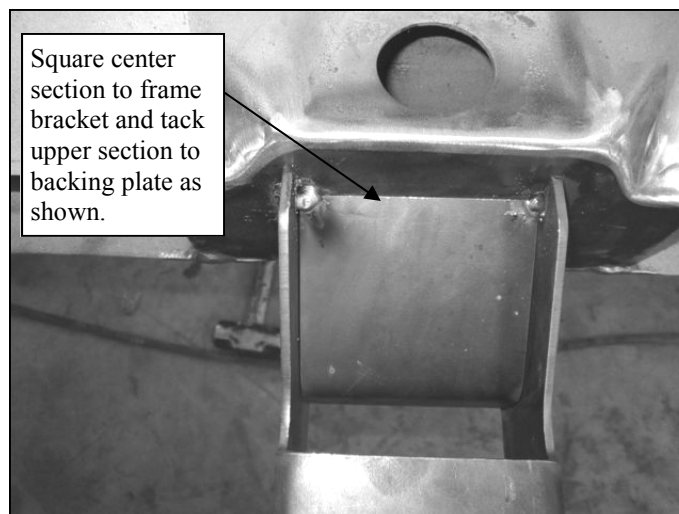
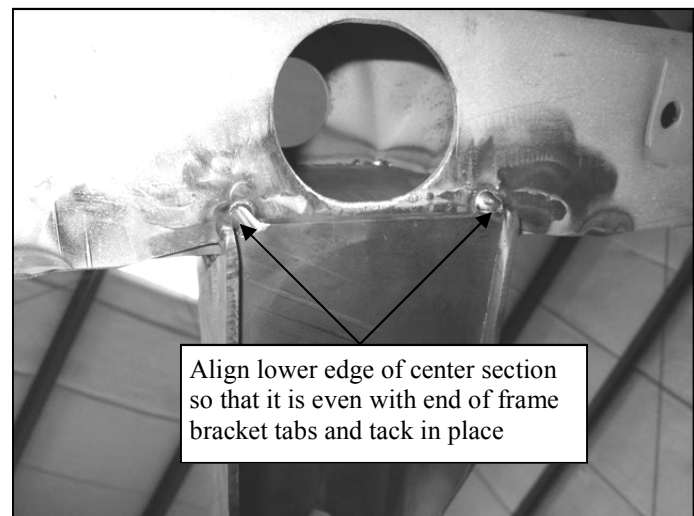
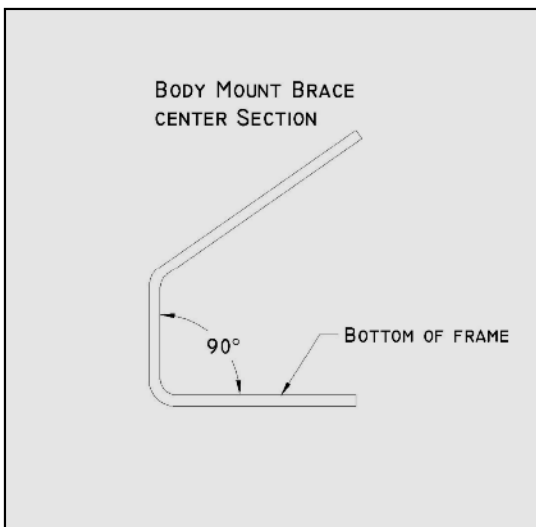

23. The lower plates can now be installed. They can be identified as shown.

Driver Side Front Lower—
Square Cutout with Chamfer

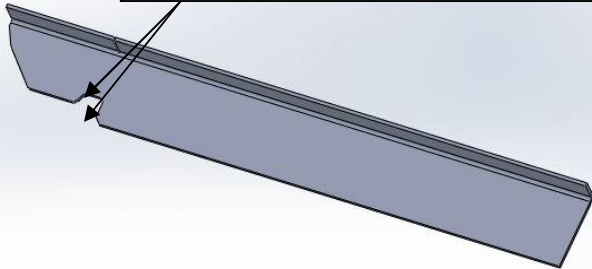

Passenger Side Front
Lower—Round Cut-
out with Radius

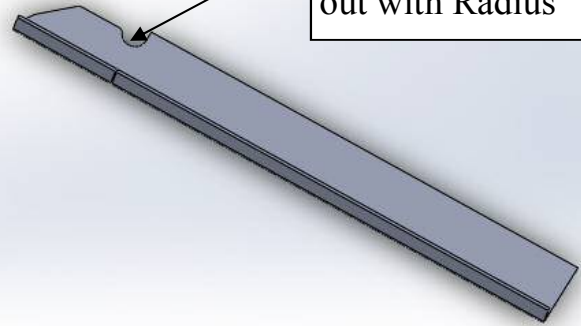

Driver Side Rear Lower—
Square Cutout with Chamfer

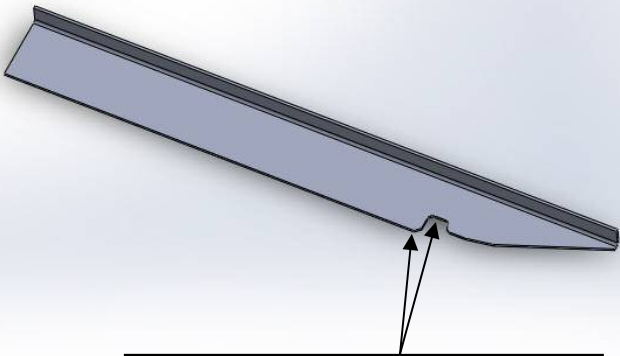

Passenger Side Rear
Lower—Round Cut-
out with Radius

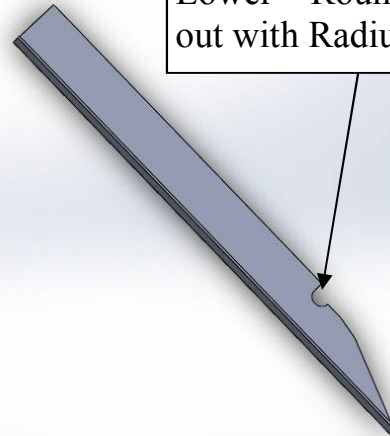

Weld 2x2" brace
between rails in
location shown.
Place brace on
top of c-section

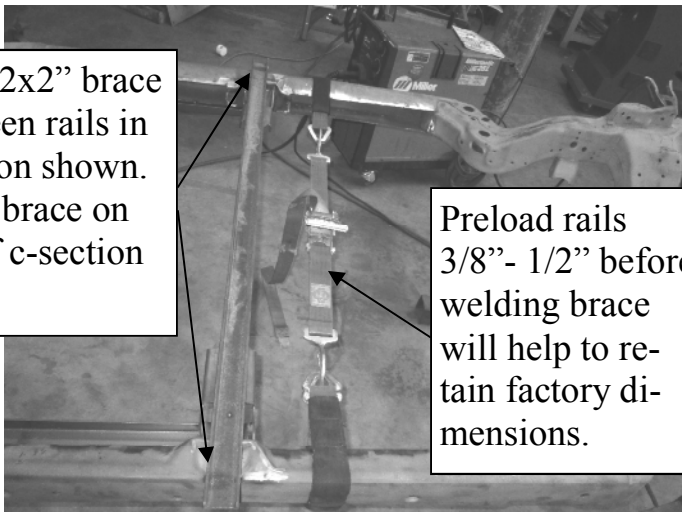

Preload rails
3/8" - 1/2" before
welding brace
will help to re-
tain factory di-
mensions.

24. Before tacking lower plates in place, it is highly recommended to weld in a brace across the top of the c-channel as shown to keep the rails from bowing outboard. Our experience has shown that the rails will bow outboard in the center from the welding heat. If you apply 3/8" - 1/2" of preload to the rails as shown before welding the brace, the rails will return to their original dimension when the brace is removed.

25. Make sure bottom flange of rail is straight. If bent, it should be hammered back into shape with a 2-3 lb hammer before mounting lower plate. The lower plate can be welded in with some gap, but for best appearance a straight flange works best.
26. Starting with the passenger side rear lower plate, fit to lower rail as shown. THE PLATES ARE MADE LONGER THAN REQUIRED TO ACCOMMODATE PRODUCTION TOLERANCES IN THE RAILS. IT IS EASIEST TO CUT THE STRAIGHT EDGE NEXT TO THE BODY MOUNT BRACKET TO FIT THE PLATE TO THE RAIL. The round cutout in the plate will allow the lower plate to transition to the rear stamping as shown. The plate will be installed so that the inside edge of the bent up flange is the same distance as the edge of the body brace center section. This will allow the upper plate to be mounted so that its profile matches the center section
27. Make sure that frame plate is square to rail and parallel with bottom edge of frame bracket before tacking in place. For best appearance keep the vertical flange of the lower plate parallel with the edge of the center section
28. Repeat for Driver side.

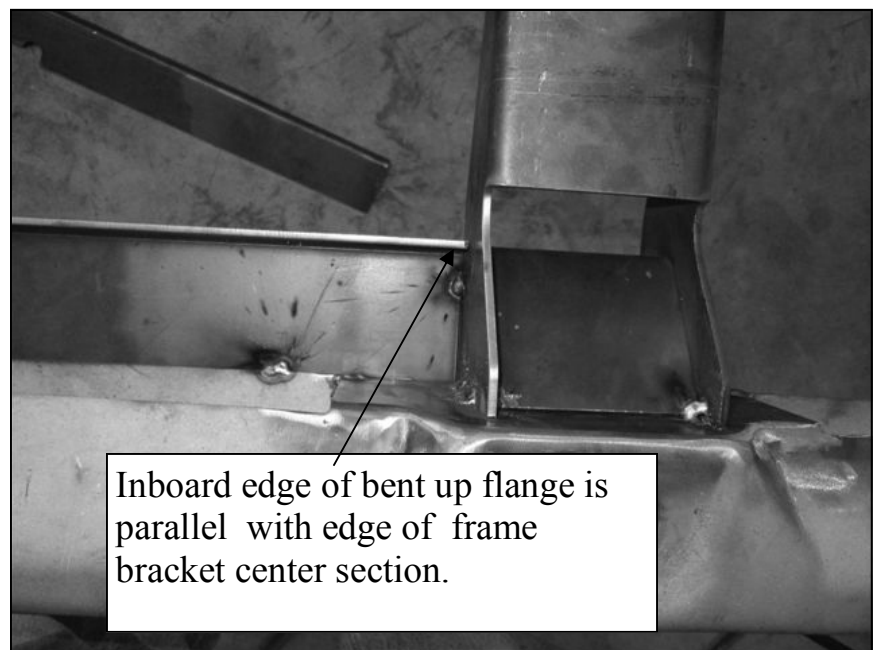
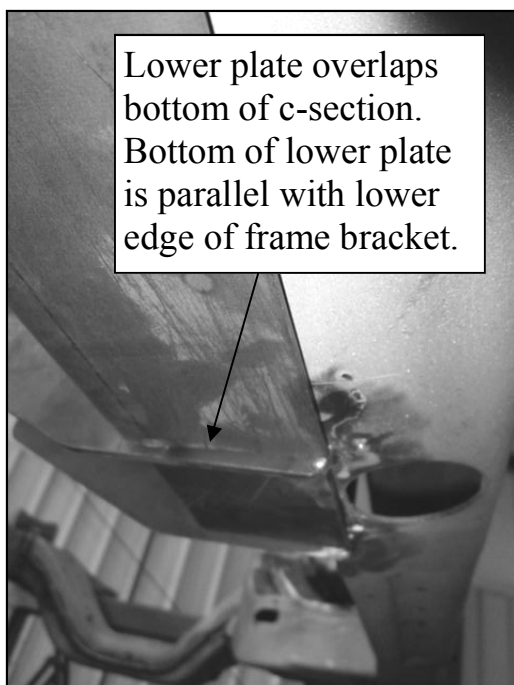
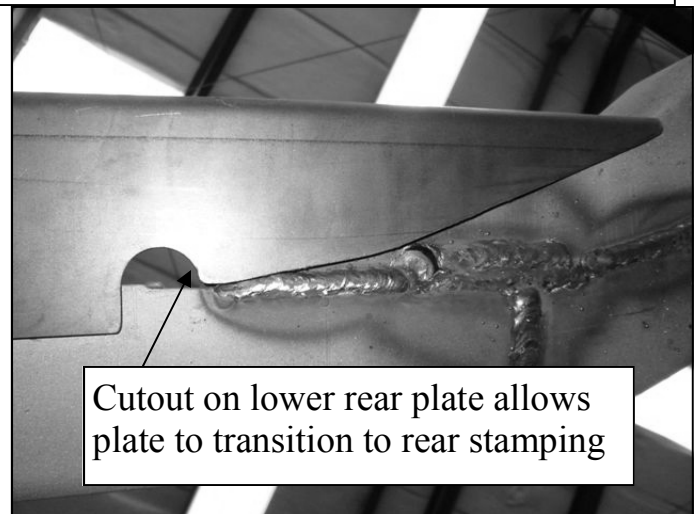
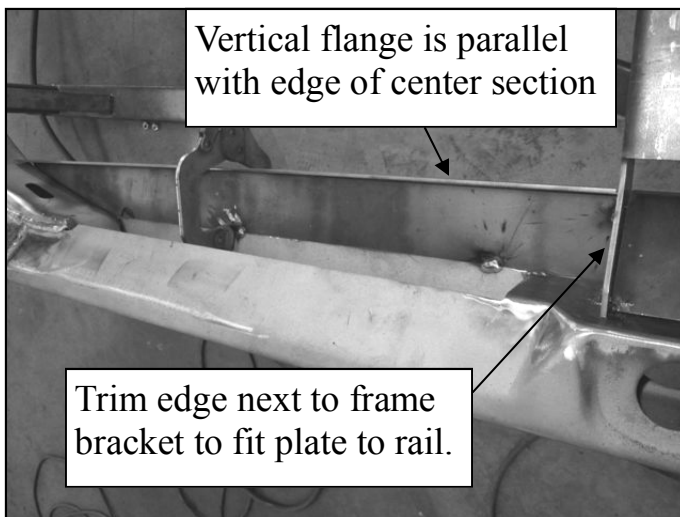

29. Fit the passenger side forward lower plate to frame rail. Again, trim the square end closest to frame bracket to get plate to get the plate's length close then grind the forward end of the vertical flange to complete fitment.
30. The round cutout in the plate will allow the lower plate to transition to the front stamping as shown. The plate will be installed so that the inside edge of the bent up flange is the same distance as the edge of the body brace center section. This will allow the upper plate to be mounted so that its profile matches the center section.
31. There will be a gap between the forward edge of the plate and the bottom of the forward frame stamping. The plate can be flexed upward to close this gap. The cut in the vertical flange will allow the plate to be flexed. This cut can be welded shut and ground smooth after fitment and tacking are complete.
32. Make sure that frame plate is square to rail and parallel with bottom edge of frame bracket before tacking in place. For best appearance keep the vertical flange of the lower plate parallel with the edge of the center section
33. Repeat for Driver side.

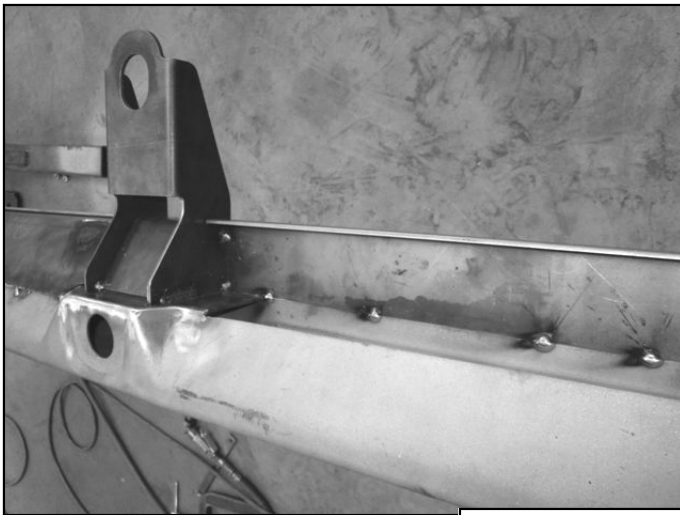

Flex end of forward plate upward to close gap
Cut in vertical flange will allow plate to be flexed. The cut can be welded and ground smooth after fitment and tacking in place.

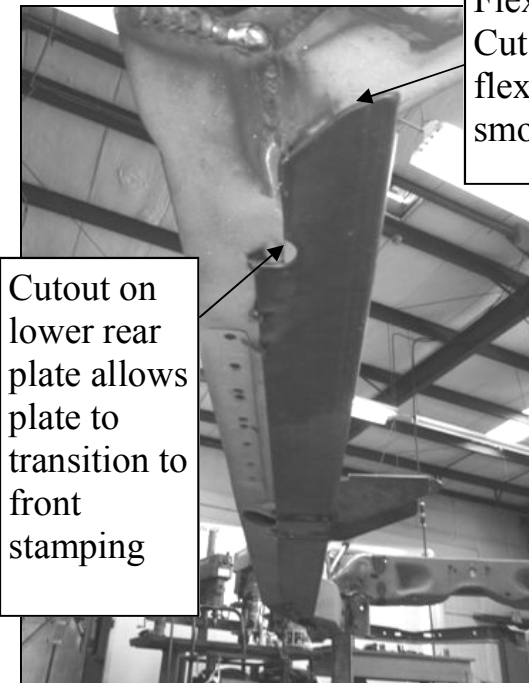

Cutout on lower rear plate allows plate to transition to front stamping

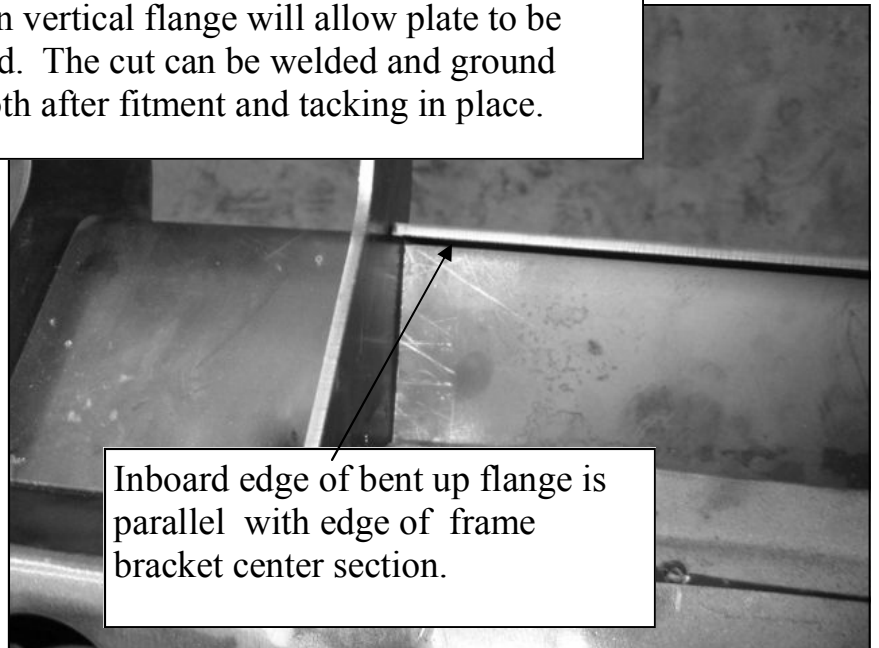

Inboard edge of bent up flange is parallel with edge of frame bracket center section.

34. The upper plates can be identified as shown.

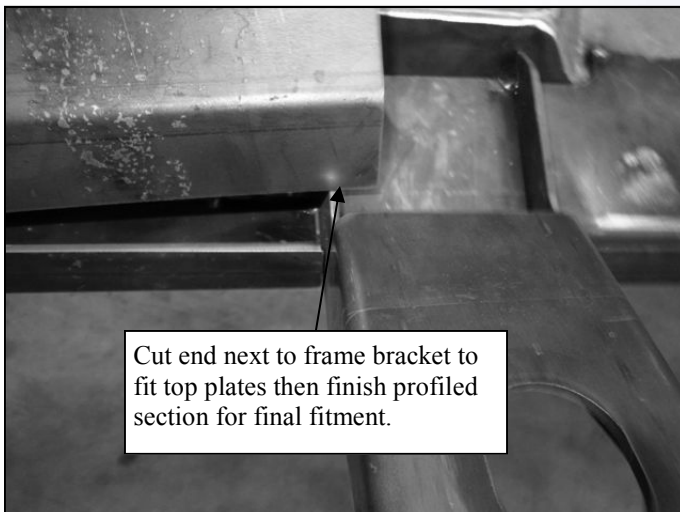
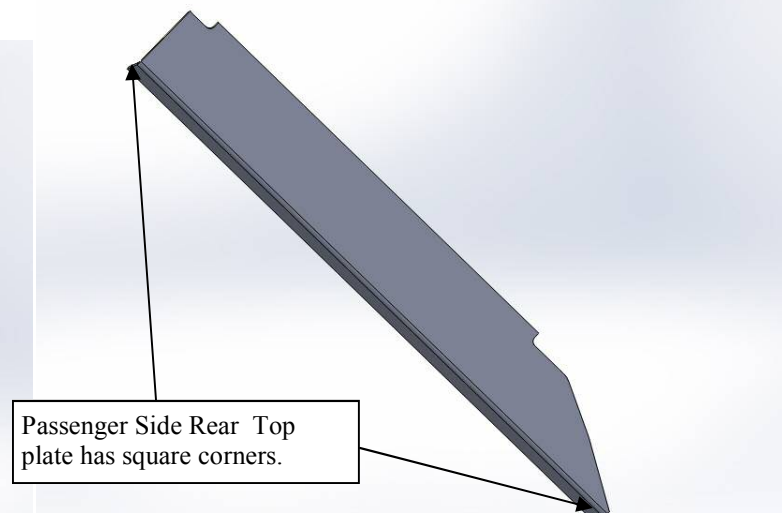
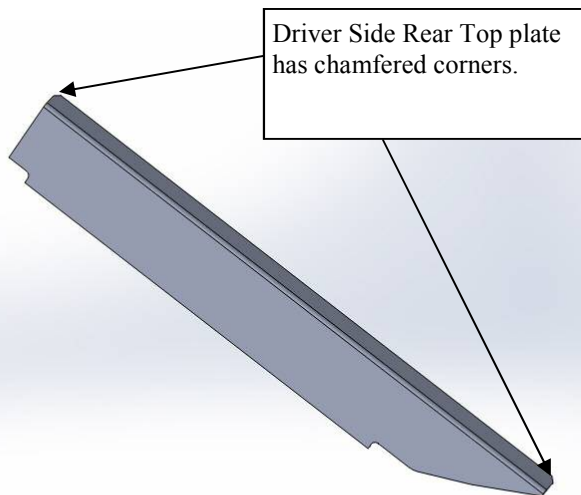
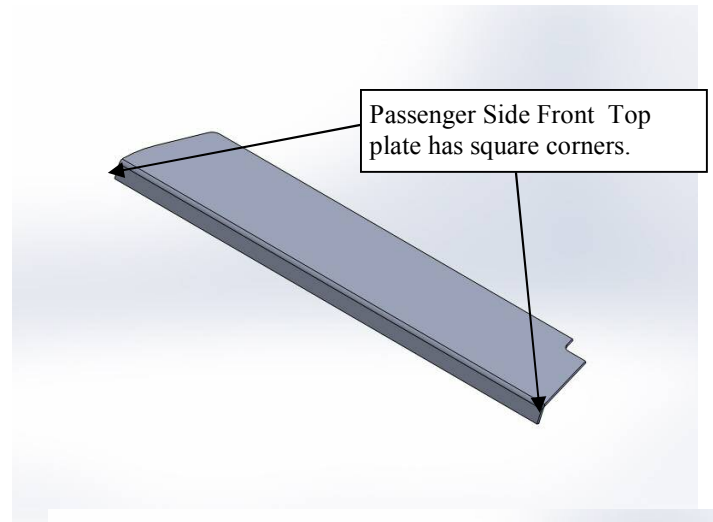
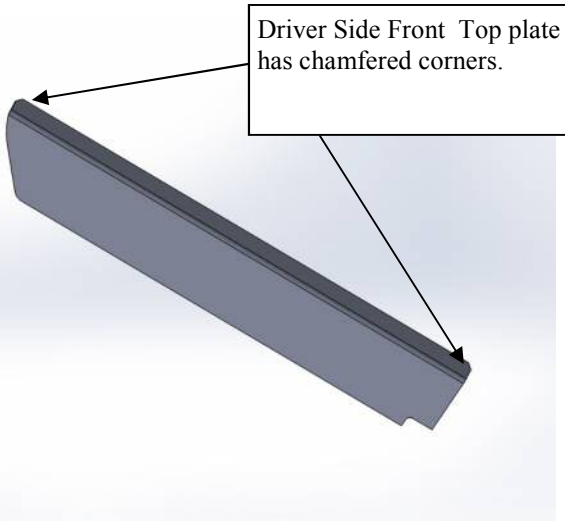

35. The upper plates are made on the long side to account for production tolerances. To fit the plates, cut the square end next to the body mount to get the fitment close and then finish the profiled section with the grinder for final fit.

Hellwig PRODUCTS

35. Starting with the passenger side rear top plate, fit to rail as shown. THE PLATES ARE MADE LONGER THAN REQUIRED TO ACCOMMODATE PRODUCTION TOLERANCES IN THE RAILS. IT IS EASIEST TO CUT THE STRAIGHT EDGE NEXT TO THE BODY MOUNT BRACKET TO FIT THE PLATE TO THE RAIL. It may be necessary to adjust cutout at top of plate next to body brace to allow the plate to sit properly. When fitted properly, the top plate will sit at the same angle as the center section of the body mount bracket. The plate will be installed with the bent tab inside the vertical tab of the lower plate.
36. Make sure that frame plate is square to rail and parallel with bottom edge of frame bracket before tacking in place. A C-clamp can be used to help bring the panel closer to the rail for tacking in place.
37. Repeat for Driver Side.

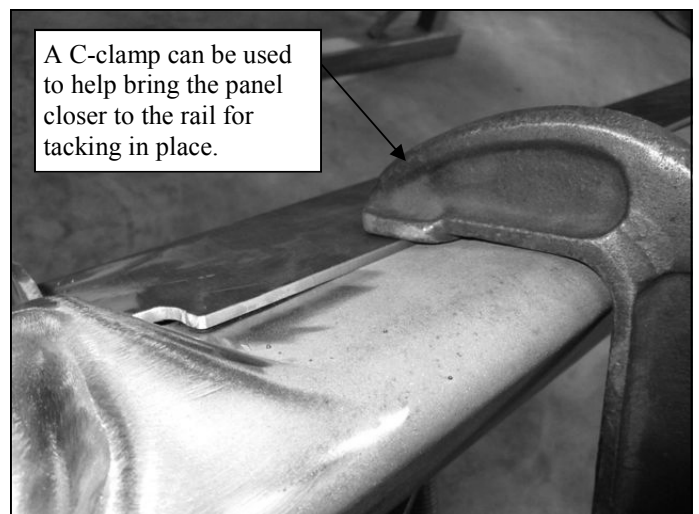
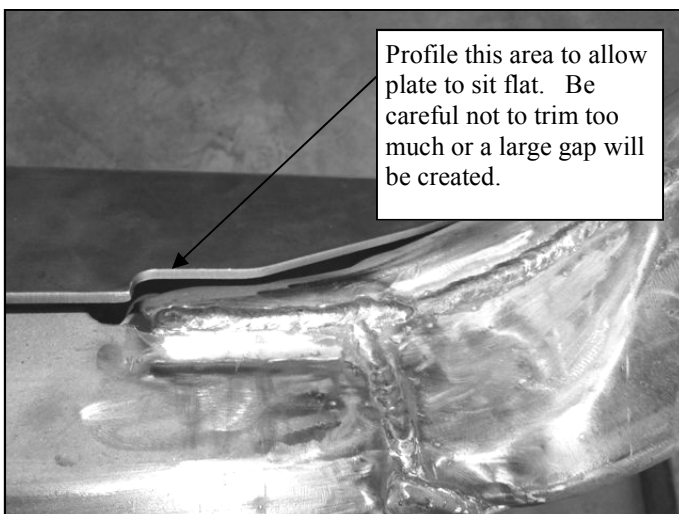
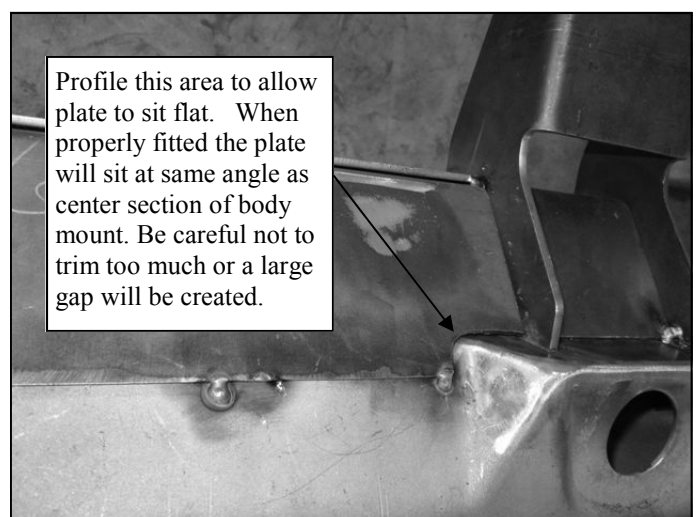
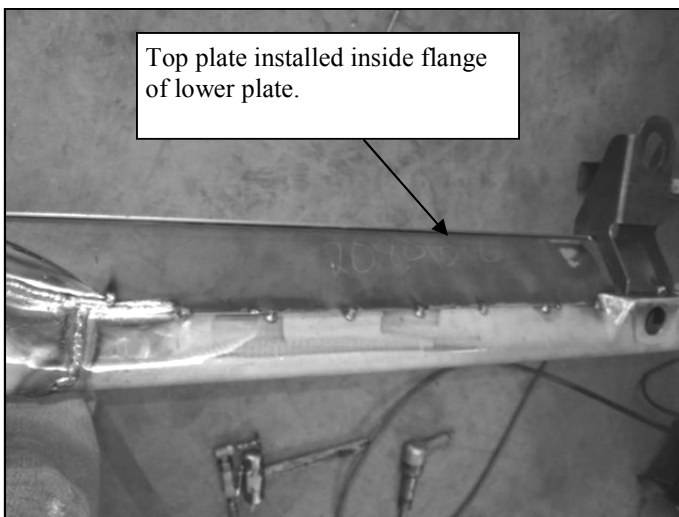

38. Prepare to install forward top plate on passenger side. The forward part of the frame rail is not a consistent height from the factory. The front edge of the top of the c-section is about 1/2" higher than at the center body mount. There are two options. Option one is to leave the rail as is. This will result in an increasing section width the closer you get to the front of the frame. This is stronger but not as visually appealing as option two. Option two is to work the top flange of the rail with a 2-3 lb hammer until it is the same height from the front to the center of rail. The steel is very malleable and can be worked quite easily. Hammer the flange over the edge of the front stamping as shown to allow the plate to sit flat. This may also require some mild trimming with the grinder to allow the plate to sit flat. This modification will provide the most visually appealing frame rail. Both will function fine, the choice is up to the installer.
39. THE PLATES ARE MADE LONGER THAN REQUIRED TO ACCOMMODATE PRODUCTION TOLERANCES IN THE RAILS. IT IS EASIEST TO CUT THE STRAIGHT EDGE NEXT TO THE BODY MOUNT BRACKET TO FIT THE PLATE TO THE RAIL. It may be necessary to adjust cutout at top of plate next to body brace to allow the plate to sit properly. When fitted properly, the top plate will sit at the same angle as the center section of the body mount bracket. The plate will be installed with the bent tab inside the vertical tab of the lower plate. Make sure that frame plate is square to rail and parallel with bottom edge of frame bracket before tacking in place. A C-clamp can be used to help bring the panel closer to the rail for tacking in place.
40. Repeat for driver side.

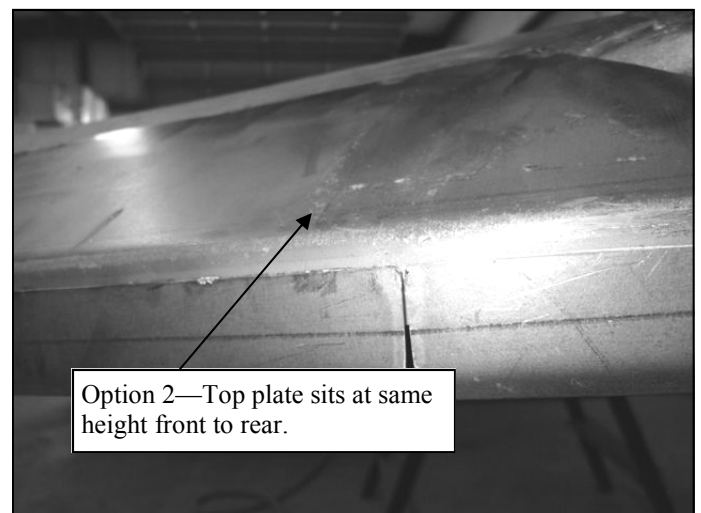
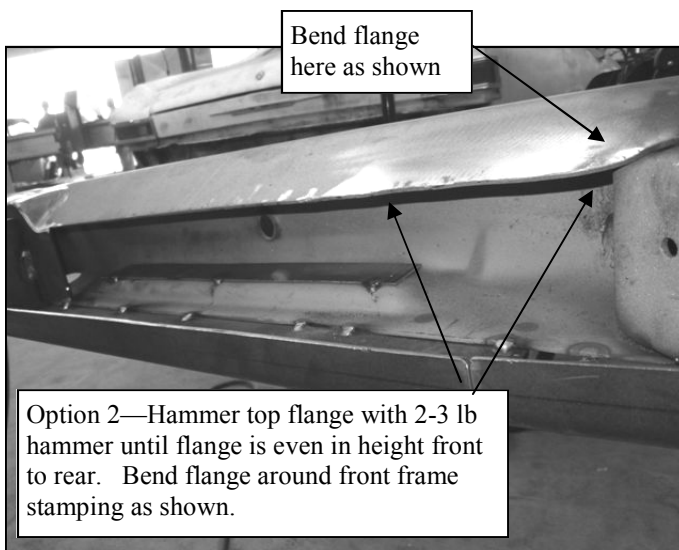
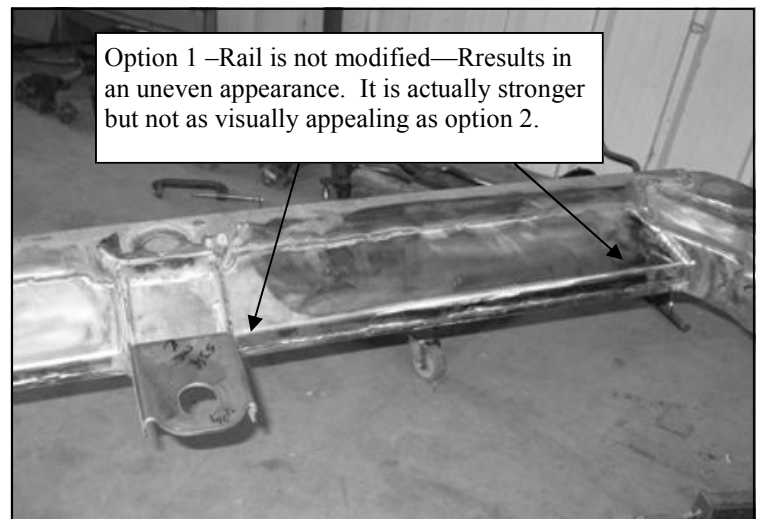
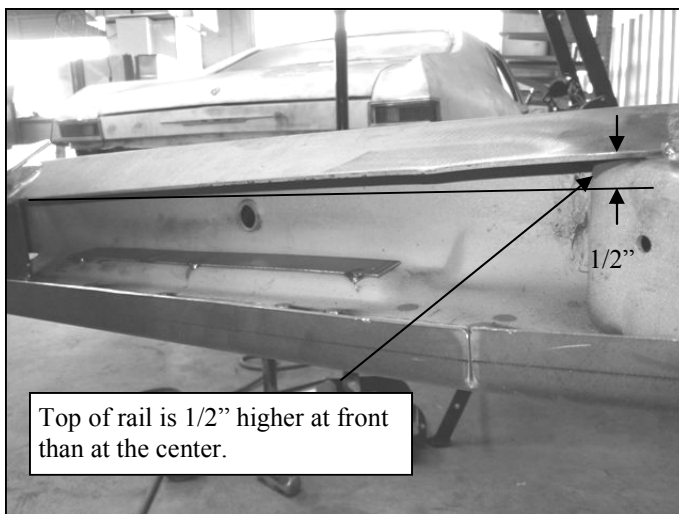

41. The panels are now ready to weld to frame rail. Extreme care must be taken to prevent heating the rails too much. Too much HEAT WILL BOW the center section of the rail. Only weld 1-1/2 inches at a time while skipping around the rail to prevent buildup of heat. It works best to weld from the center section/body brace outward. When welding the panels to the rail, the backstep or skip welding technique will help to minimize warpage. The key to a successful install is to TAKE YOUR TIME. Make 3-4 welds in various locations, then allow it to cool. This will keep warpage to a minimum. The rails will move 1/8-3/16" from your initial dimensions by the time you finish welding. With this amount of movement, the rails will still bolt up properly to the vehicle. If you do manage to warp your rails much beyond this amount, a good frame shop can bring them back into shape—for a fee. Its much easier—and cheaper—to take your time and not be in a hurry.

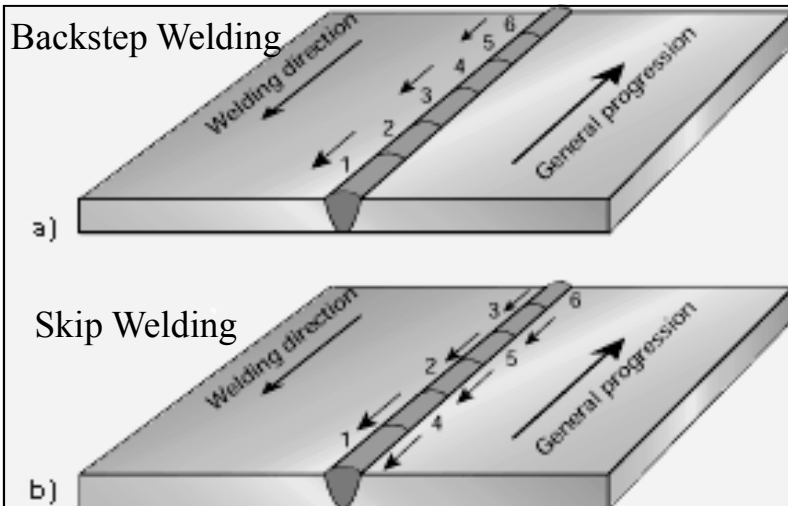
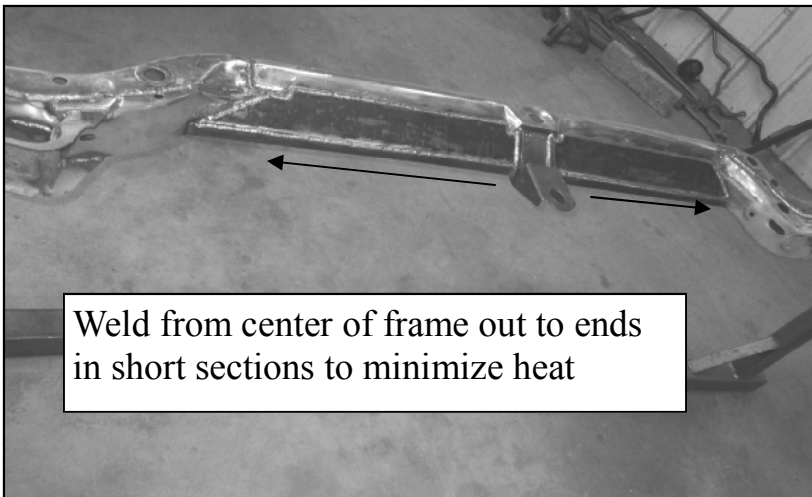

42. The transmission mounts can now be attached to the frame rail. Locating the transmission mounts will require the engine and transmission to be installed. The mounts are long enough to accommodate future driveline modifications. Careful planning will allow the mounts to be used in the future without having to cut or re-weld. Attach the mounts to the bottom of the rail. Tack in place and make sure they are level. Weld as required using backstep or stitch technique to minimize heat.
43. The existing transmission crossmember is used with the adapter plates shorten it to fit on the new transmission mounts. Center the crossmember on the frame and mark the crossmember at the inside edge of the transmission mount. This is where the crossmember is to be cut. Bolt crossmember to transmission and tack adapter plates to crossmember. Fully weld adapter plates to modified crossmember. Attach crossmember to transmission and mark holes in transmission mounts. Drill $13/32''$ (.406'') holes in transmission mounts and attach crossmember with $3/8''$ X 1'' bolts, washers and locknuts.

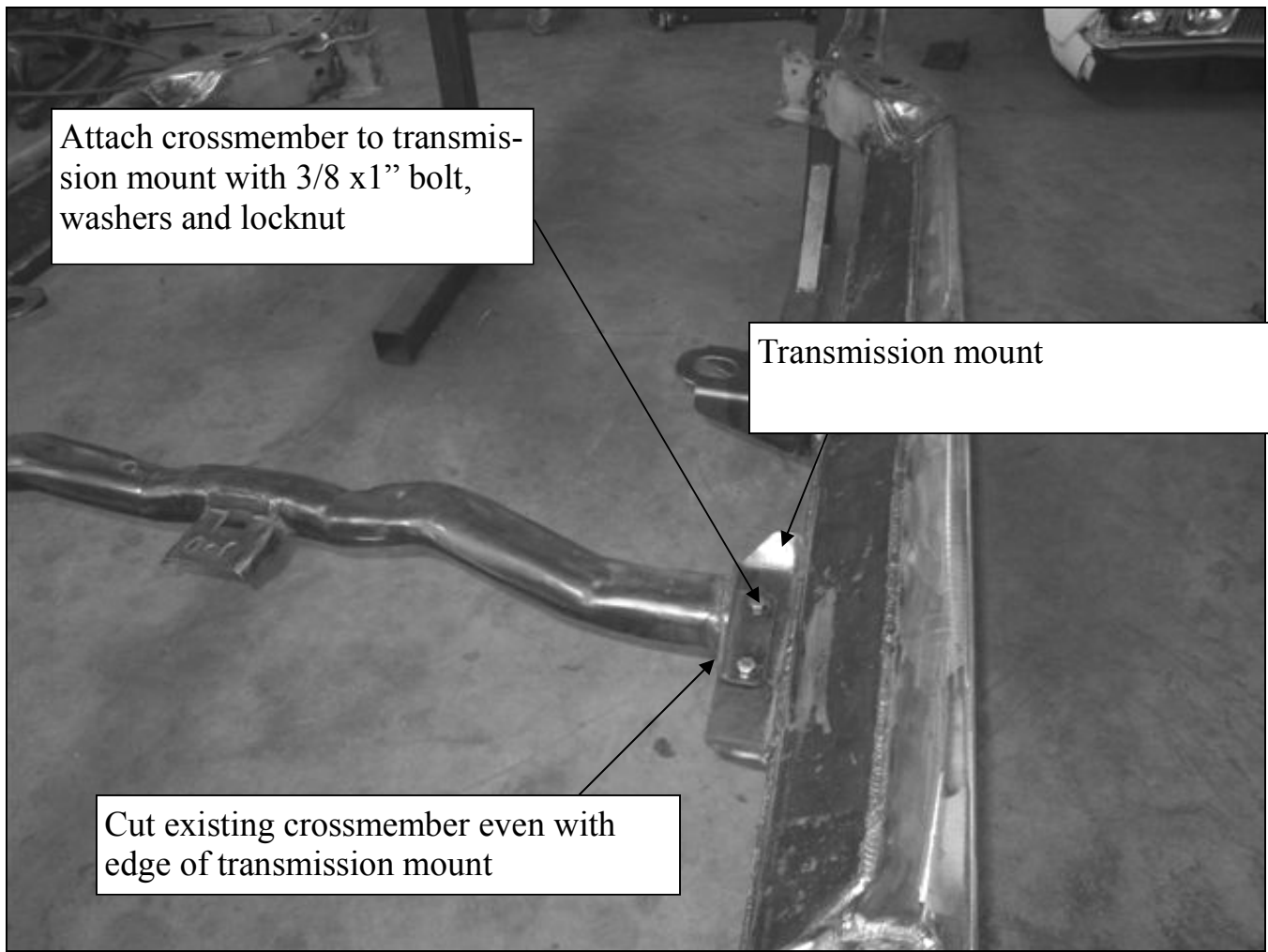

44. You are now ready to enjoy your newly strengthened frame. Coat rails with the paint of your choice and reassemble to vehicle with new body mounts.



Learn more about performance suspension parts we have.