

Mounting instructions



Hella Rallye 4000 Series Metal / Chromium / Celis



Kit includes

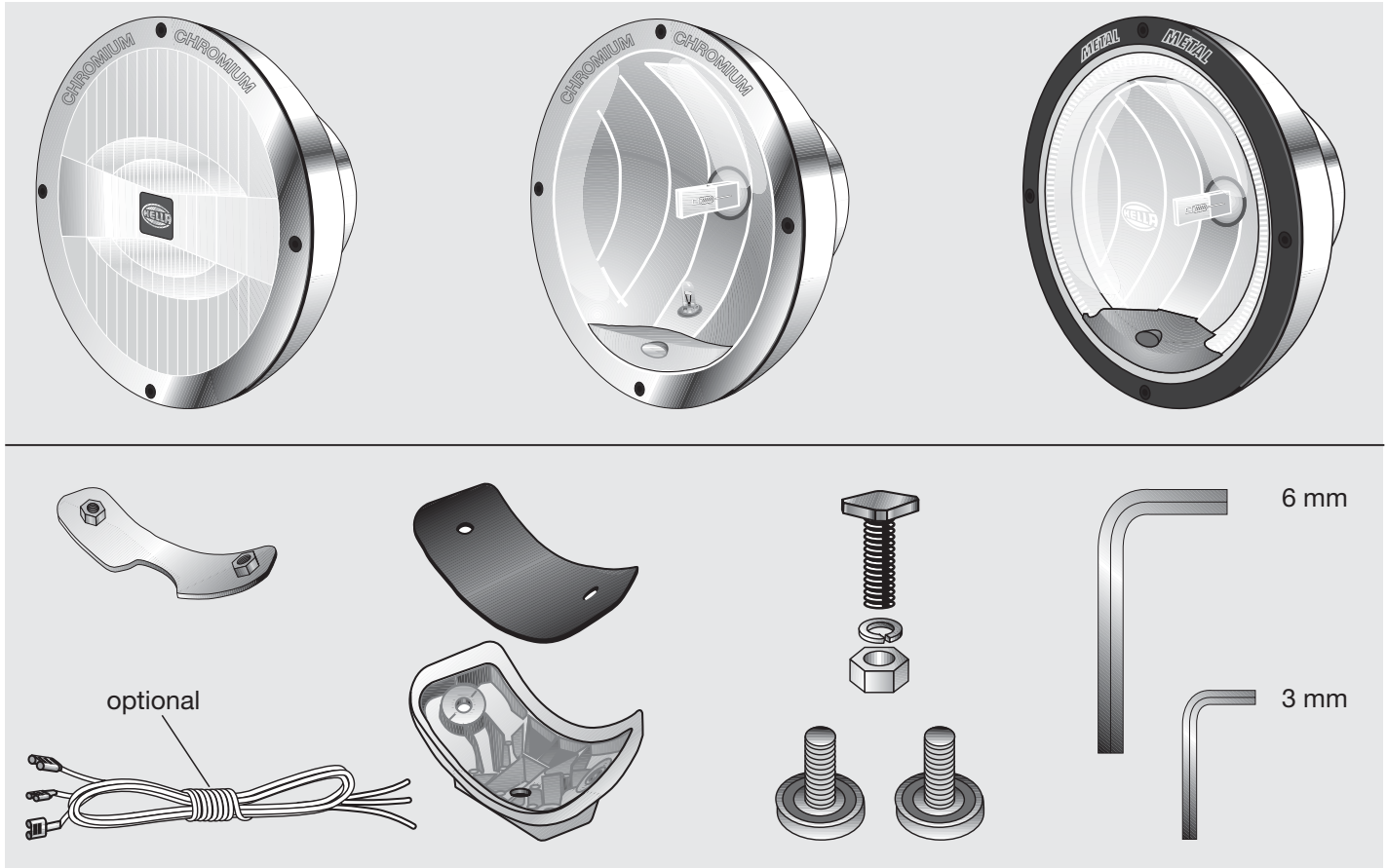

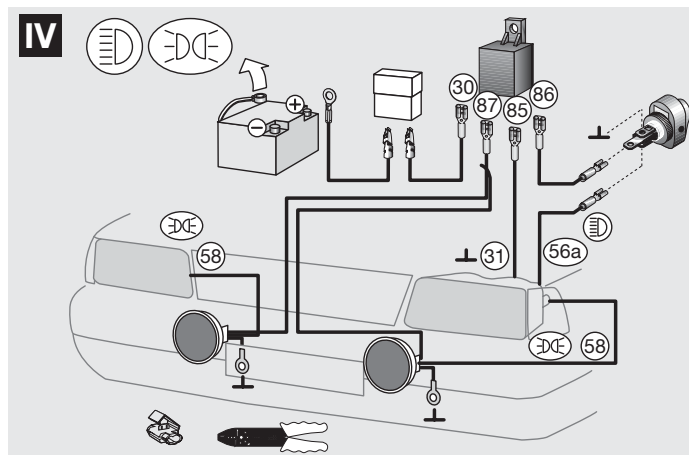
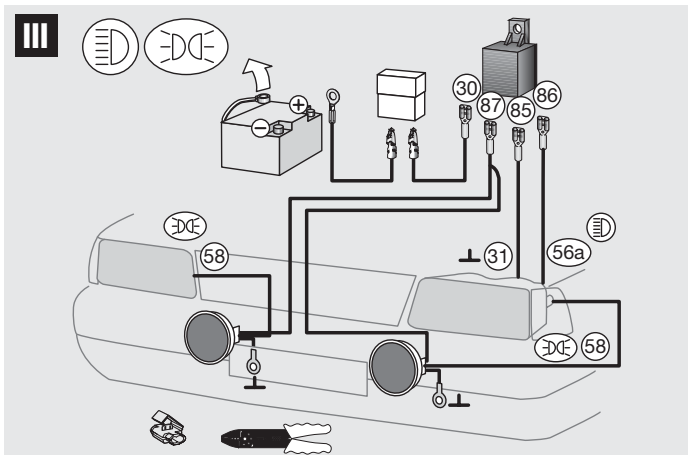
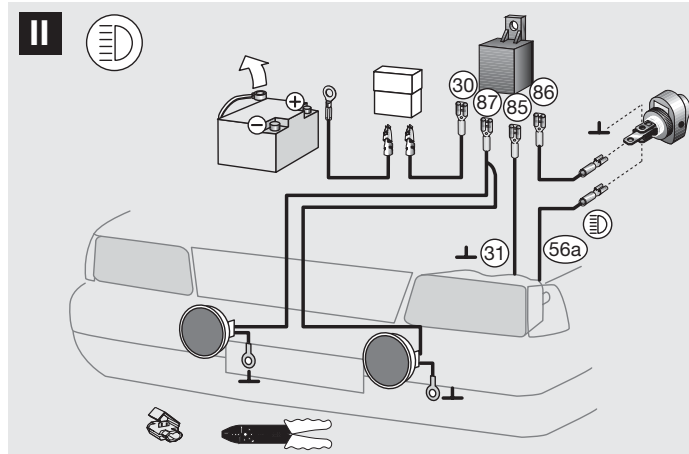
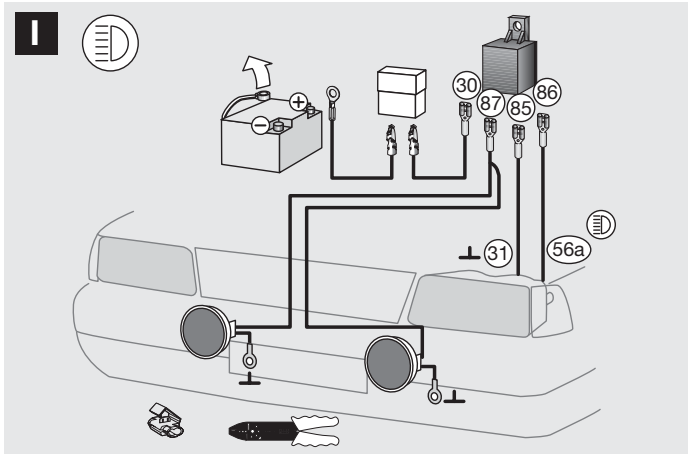

Rallye 4000 Celis

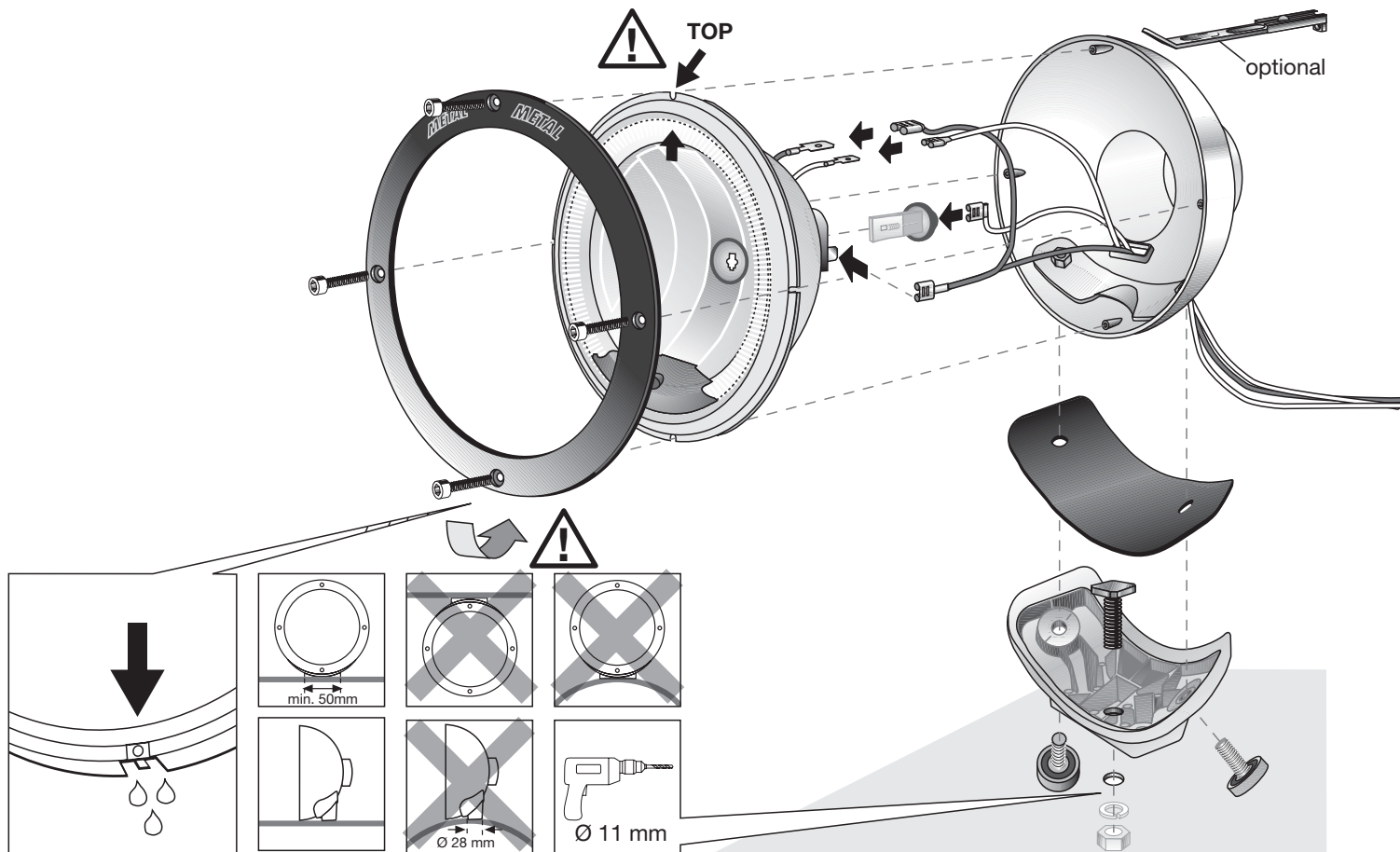

Rallye 4000 Chromium / Metal

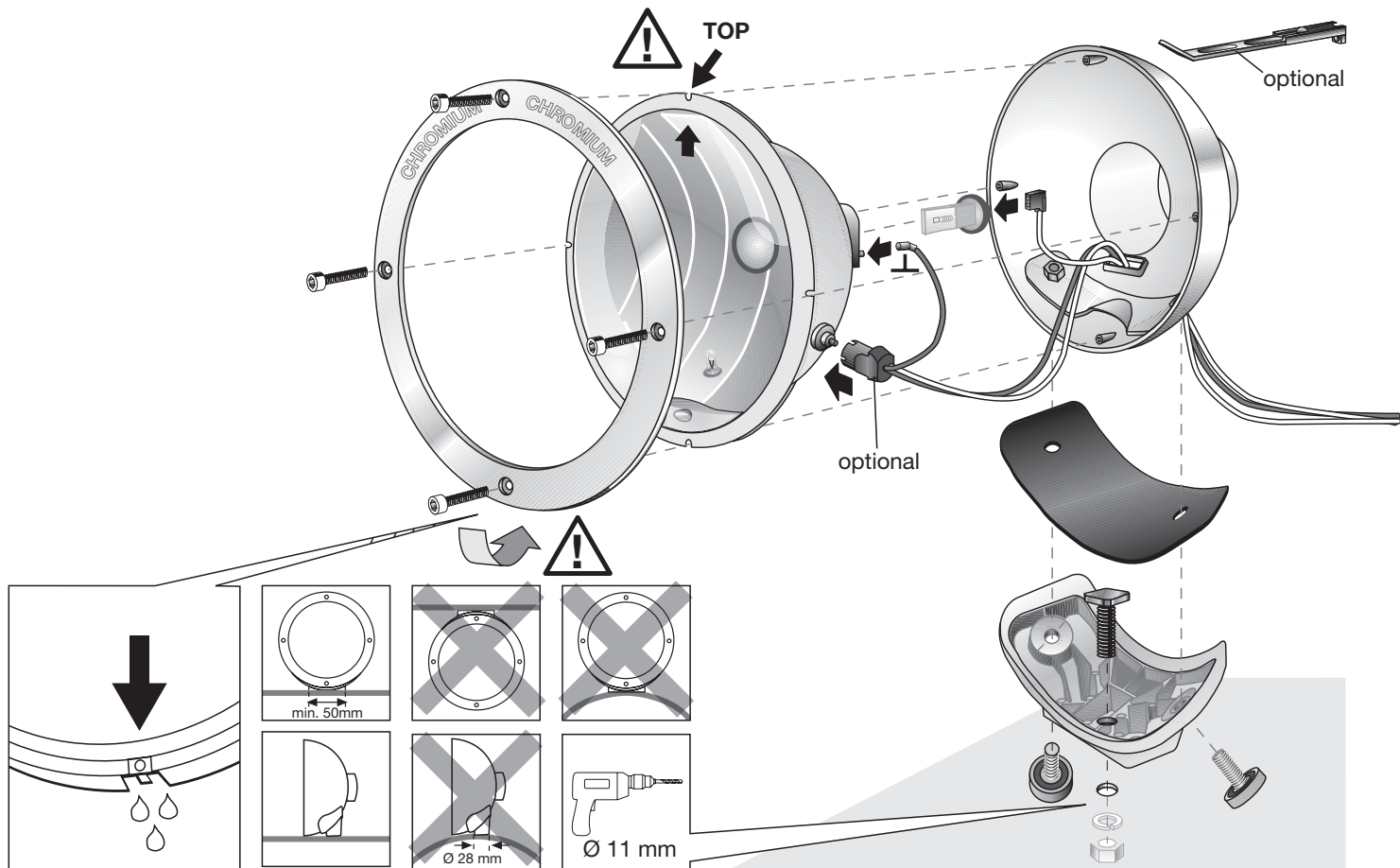

Accessories (not
included with lamp set)

1. Protective grille
9HG 148 995 001
2. Single pole wire connector
8KV 705 123 813
3. Two-point mount
8HG 116 741 801
4. Switch 6EH 007 946 04
5. Hella wiring harness with
relay and fuse (12V)
8KA 148 541 001
6. Bulbs:
(H1 12 V / 55 W =
Part no.: 8GH 002 089-131)
(H1 12 V / 100 W =
Part no.: 8GH 002 089-251)

Subject to alteration without notice

Installation dimensions

Important:

Before mounting check whether the air supply to the radiator grille will still be sufficient (for cooling engine). Mount both lamps above the bumper. Lamps may not vibrate or extend above the bonnet and must be attached symmetrically.

The use of an additional pair of parking lamps is not allowed in Great Britain. This means that the additional mounting instructions do not apply for Great Britain.

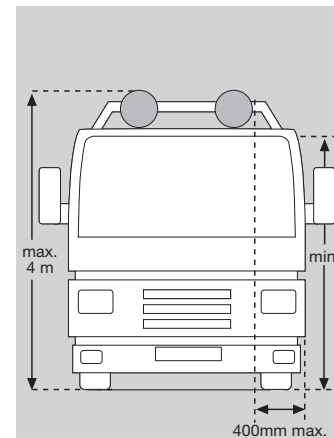
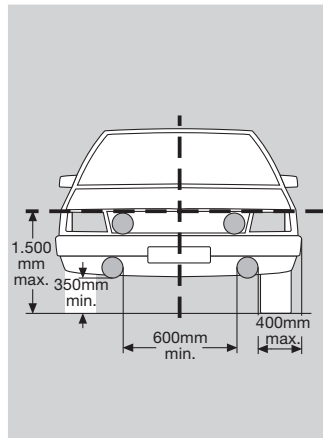

Mounting instructions Fig. page 4/5

Tools required:

- Pliers for crimp connectors
- Folding rule
- 3 mm and 6 mm dia. Allen keys
- Open-jawed spanner = 17mm
- Drill with 11 mm dia. bits
- Universal pliers

Remove the glass retaining rim and take out the headlamp insert. Mark fixing points for the headlamp base on a stable surface and drill.

Seal drilled holes with antirust! We recommend upright attachment using the two-point mount available as an accessory from stockists.

Screw the headlamp base to the mounting surface and the lamp base "hand-tight" to the housing. Insert the correct Hella bulbs (available as accessories from stockists) and attach the wires. **Do not touch bulbs with bare fingers!** Use paper tissue or similar!

In order to guarantee an optimum beam pattern, make sure that the „TOP” mark on the headlamp insert is always pointing upwards when mounting is carried out. Then attach the glass-retaining rim and screw tight. The retaining lug should be pointing towards the base.









Electrical connection: Fig. page 4/5

Use the Hella wiring harness developed especially for this purpose or connect the headlamps as follows:
Install the correct Hella relay (available as an accessory from stockists) with the connection terminals pointing downwards to protect it against splashwater.

24 V headlamps
Relay part no.:
4 RA 003 510-651
12 V headlamps
Relay part no.:
4 RA 003 510-641

Choose the **circuit diagram (I – IV)** applicable for you in the adjacent table. **Circuit diagrams I and III*** show the auxiliary lamps connected so that they are switched on with the existing driving lamps. **Circuit diagrams II and IV*** show the auxiliary

lamps connected in such a way that they are switched on in addition to the existing driving lamps via a separate switch. A switch must be installed in the dashboard accordingly.
Lay the wires according to the respective circuit diagram and insert the plug on the rear of the lamps. Reconnect the ground cable (-); check lighting system!

	I	II	III	IV
				
				
	•	•	•	•
	•	•		

(***Circuit diagrams III and IV** incl. position light)

Lamp adjustment:

Have your driving lamps adjusted at a specialist garage so that they illuminate the road effectively without dazzling oncoming traffic. After adjusting the lamps tighten the lamp base on the housing.

Special instructions for Germany only.

The enclosed cap may not be fitted.

One more tip:

- Always keep the cover lenses clean. Dirt can absorb up to 80% of the light from the lamps. You drive better when you can see and be seen well. Do you have spare bulbs and fuses in your car?

Should you have any queries or problems about the installation, please contact the Hella Customer Service Department via your local stockist.