

1941-1948 FORD IFS



IMPORTANT INFORMATION!

- 1** Read these instructions fully before starting your installation.
- 2** MEASURE TWICE, WELD ONCE!

1 Preparing the Frame

Support the vehicle on four jack stands, making sure the vehicle is resting at approximately the same angle it sits on the ground. Remove all suspension components, including the stock crossmember and the steering box mount. If the radiator support is not in place, tack weld a temporary brace across the frame. Next, plug the two large holes inside the frame, just behind the axle centerline. See **Figure 1**. Using the center of the rubber snubber holes as a reference point, scribe a line around the frame rails to denote the axle centerline. Then trim the inner lower flanges of the frame rails to the 1-7/8" dimension shown in **Figure 1**. Finally, dimple the outer frame rails for the coil springs with the dimples centered on the axle centerline. See **Figure 2**. The dimples should be about 3/8" deep at the top.

2 Installing the Crossmember

Your crossmember came with the lower A-arm gussets pre-welded, but if they aren't there, you will need to quickly weld them on. Enlarge the holes where the lower control arms attach to the crossmember to 5/8". Mount the rear spacers and crossmember spacers onto the crossmember. See **Figure 3**. Use the supplied inner bushing bolts and nuts with a temporary spacer under the nuts. **NOTE: Do not use the A-arms for this step, as the heat from welding will melt the rubber bushings.** Tighten the nuts and bolts and weld the rear spacers to the crossmember on all sides. Weld the crossmember spacers as far as possible inside the crossmember on both ends. Next, position the gussets horizontally against the back of the crossmember and the rear spacers and weld to the crossmember. Remove the bolt after the welds have cooled. Position the new crossmember into the frame, centered on the axle centerline. See **Figure 4**. Weld securely on all sides after measurements have been double-checked.

3 Assembling the Components

If a temporary brace was installed across the rails, it can now be removed. Next, install the spring towers on top of the frame rails. See **Figure 5**. The spring towers should sit 1-9/16" forward of the crossmember when measuring from the front of the crossmember to the front of the spring tower. Double check measurements and securely weld on all sides, including the flanges on the sides of the rails. Assemble the rest of the [suspension components](#) and place the vehicle on the ground. Set the camber, caster and toe-in:

Caster: 1° positive
Camber: 1/2° positive
Toe-in: 1/8" +/- 1/8"

4 Final Adjustments

Check the installation and the alignment after a few hundred miles. The springs should have settled so the lower control arms are parallel to the ground. If the vehicle is still sitting too high, switch to softer springs or cut up to one coil off the bottom of the springs.

Figure 1.

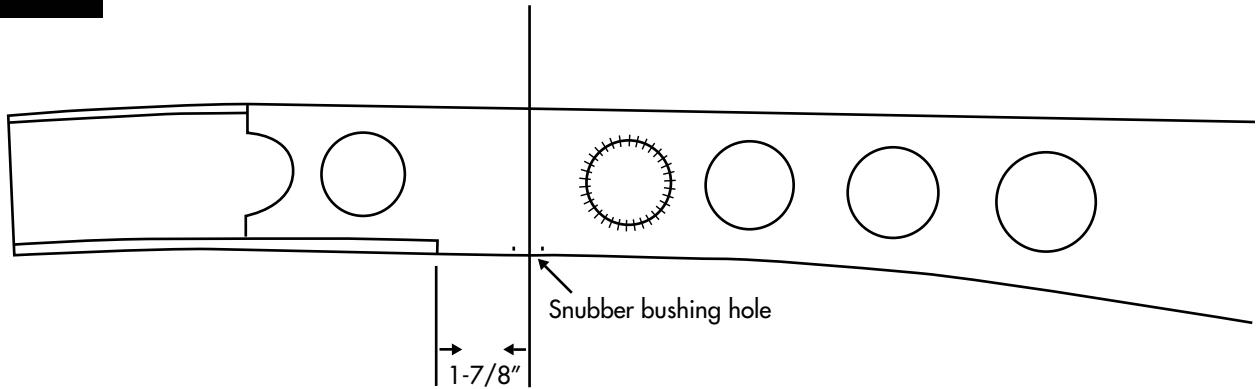

Figure 2.

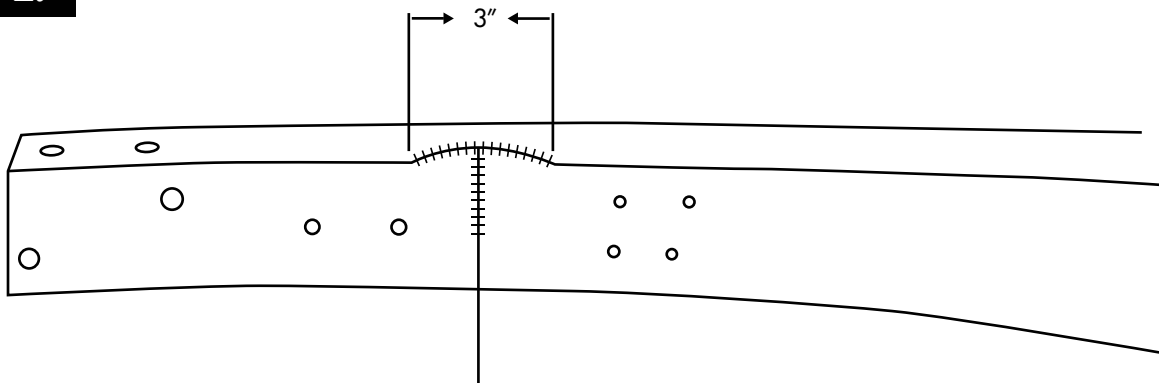

Figure 3.

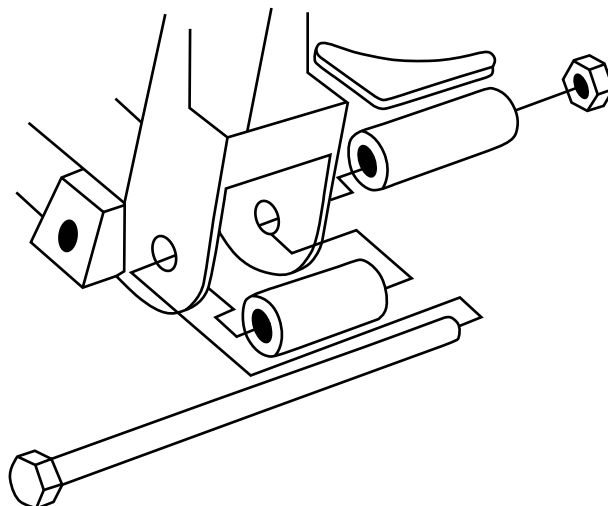

Figure 4.

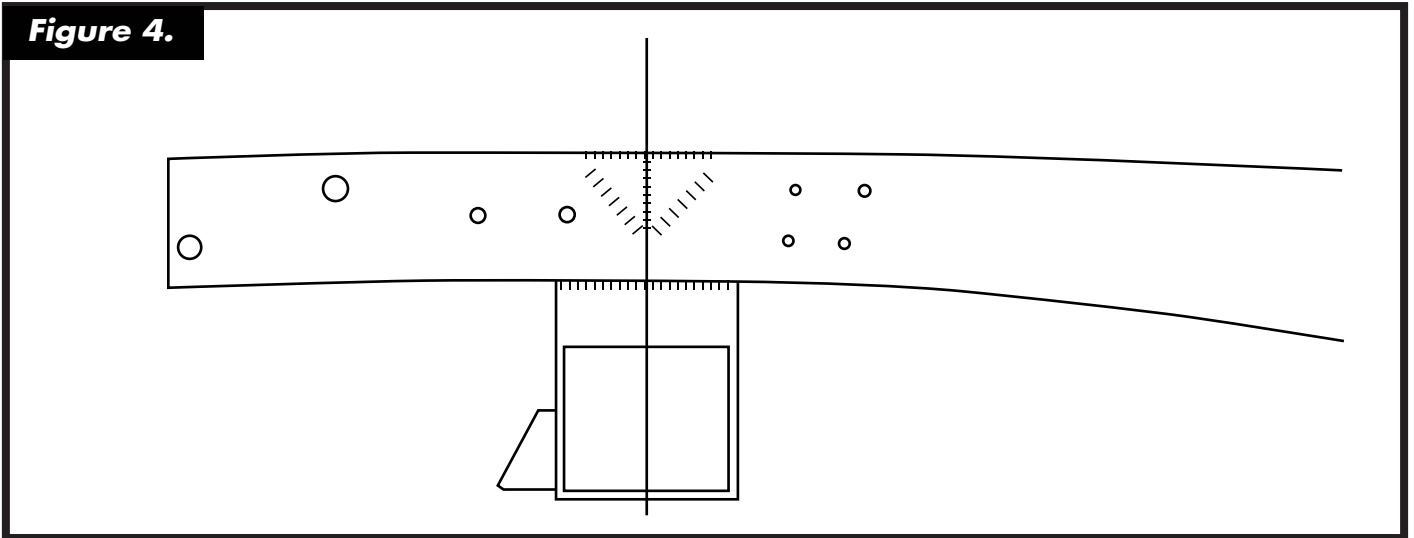
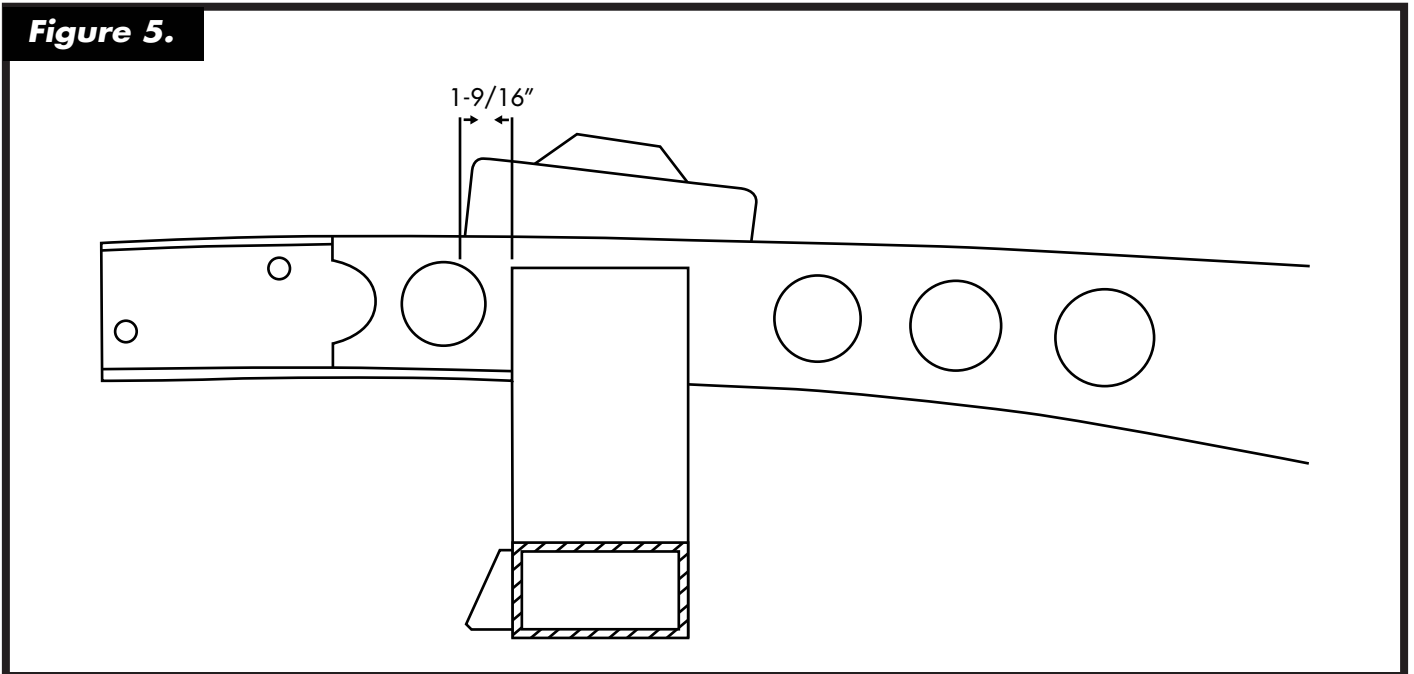

Figure 5.



Remember: Measure twice, weld once!

1 Determine Correct Center Line:

If original suspension still in place:

A. Transfer centerline of spindles with vertical line onto side of frame rails.

Note: The maximum standard frame width that will fit between springs is about 30". If your frame is wider than that, it will need to be C-notched for springs. If you still have original suspension on frame, it must be removed at this point.

If original suspension is not in place:

A. Position a fender in place on the frame, then stand the front wheel with tire in place of the fender.

B. Slide a tube or other straight implement straight through wheel center.

C. Mark a vertical line at location where it contacts the frame.

D. Place spindle centerline in center of fender opening. At this point the spindle centerline is in center of the fender opening.

E. Now that you have the spindle centerline, measure the width of frame at that point. The maximum standard frame width that will fit between springs is about 30". If your frame is wider than that, it will need to be C-notched for springs. If you still have original suspension on frame, it must be removed at this point.

2 Determine Vehicle Ride Height

Determine ride height of front suspension and of entire car, as frame must also be set at correct rake that the finished car will sit.

A. Adjust height of frame, or entire car, to the desired height, and then support frame on jack stands with shims at this height.

B. Check height of spindle by using your set-up wheel, compared to height of frame rail at axle centerline.

C. Mark actual spindle centerline height on side of frame rail (*Note* : subtract 1/4" from centerline location for flattening of tires under pressure). If it comes through the wheel below the frame rail, then temporarily tape a piece of cardboard to side of rail to mark centerline on. Please note the bottom of the frame should be no lower than one inch below spindle and the top no more than four inches above the spindle. At this point you can adjust ride height of your car within this range, if your frame is smaller than these dimensions (See Figure 1). You can also adjust the position of the crossmember, and the frame, with 2" Dropped Mustang II Spindles, if the frame does not fall within this range. Note that if frame is more than 1/2" below spindle, it will need to be C-notched for rack boots if you do not use dropped spindles. Also note that if you have a thicker frame, remove a 12" long section off and box in top of the frame for spring tower and upper control arm clearance. Later steps will determine the depth of the section to be removed.

3 Crossmember Cuts & Mounting

For proper installation you need to determine the inner width of the boxed frame rails for your vertical cut. To do this you need to determine the correct horizontal cuts by

A. Using the lower control arm pivot bolts that are 3-1/2" below spindle centerline on standard Mustang geometry. Measure down (or up) from spindle centerline mark to bottom of your frame rail.

B. Subtract (or add) your dimension from 3-1/2" and difference will be the dimension from control arm inner bolts to horizontal cuts on crossmember.

C. Repeat step B twice- 1-3/4" forward and rearward of spindle centerline, as this is where crossmember will contact frame (See Figure 3). Please note the frame is tapered and sitting on an angle, so front and back cuts are almost never the same. It is important to remember that the crossmember should be level, both side to side and front to back.

- D.** Transfer dimensions to crossmember. Please note the rack mounts are located on the front of crossmember. It is important to double check all measurements and cut the crossmember. In order to insure a proper fit you need to cut off slightly less than you measured for tight fit. At this point in time the crossmember is centered on spindle centerline.
- E.** When crossmember is in place, check to make sure it is level, then tack weld in place.
- F.** Verify the crossmember is as high in the frame as desired. To do this, temporarily assemble the lower control arms and spindles onto crossmember.
- G.** Temporary clamp a 2x4 under crossmember with a couple of shims to support the control arms level and stand spindles up on ball joints.
- H.** Verify ride height. If your ride height is not as desired, then remove crossmember and remove or add material as needed, then retack in place. Please check upper control arm mounts and confirm they do not need adjustments for positioning of the crossmember.

4 Upper Control Arm Mount & Spring Towers

Please note the upper control arm mount & spring towers installation are more complicated than the crossmember installation. The spring towers are placed 1 1/2" forward of the front of the crossmember. Use the chart below to determine the horizontal position of the spring towers. To provide better built in caster the Upper Control Arms offer a 1/8" off-set.

Part Number	Track Width	Spring Tower Position
M2U	56.5"	33.5"
M2W	58.5"	35.5"
M2X	60.5"	37.5"

Using tapered boxing plates as gauges, do the following to ensure proper installation.

- A.** Stand plates on edge on top of the tops of the crossmember, up against the frame boxing plates, with thick end towards front (See Figure 4). This will create a 3 degree taper that is the anti-dive.
- B.** Hold the spring towers against the outside of the frame so they line up with the boxing plates and transfer the front location of the frame top surface onto spring towers.
- C.** Hold the spring towers against the outside of the frame so they line up with the boxing plates and transfer the rear location of the frame top surface onto spring towers.
- D.** Confirm correct installation by holding the spring towers on top of frame and to the specified dimension per track width as found in the above chart. Then make sure that they are aligned. You can do this by confirming the slots for upper control arms are in line with each other from spring tower to spring tower.
- E.** Mark the spring towers vertically from outsides of the frame rails (See Figure 5). Make sure that the upper spring plates (surface with two slots) are flat to each other from one spring tower to another spring tower across frame. In addition the spring mount cups should be tilted slightly up for antidive.
- F.** Clamp a piece of bar or tubing onto slotted surface from one spring tower to other to keep them flat for measurement.
- G.** Start cutting the spring towers to fit. It may take a couple of cuts and some fitting to make a tight fitment. In the event your measurements show, the back of the spring towers need to be cut so it is less than 1", you will need to either raise the entire crossmember and spring towers and reconsider selected ride height, or remove part of top of frame and box it in. Please note the upper control arm rear needs a minimum of 1" height for clearance (See Figure 6). Helix's heavy duty crossmember allows you to do major modification to a frame while increasing strength and ride quality.
- H.** Tack weld spring towers in place.
- I.** To ensure correct installation and placement, double-check measurements again.
- J.** Trial assemble the upper control arms onto the spring towers and spindles. When done correctly the suspension in this position is the actual, true ride position when driving the car. The spindles should be straight and square, with approx. 1 degree tilt rearward (caster) when the upper control arms are centered in the mounting slots. In addition check that the spring towers are lined up with the tapered gauge plates when stood on tops of crossmember uprights. To confirm correct installation, the gauge plates should be at the 3 degree anti-dive angle. In the event the the gauge plates do not line up, or the spindles cannot be brought into position, the spring tower location may need adjustment.
- K.** Test fit the steering rack by installing it to the crossmember. Installation is correct if the steering rack clears the frame by 1/4" or more. In the event you do not have 1/4" clearance you will need to C - notch the frame for the rack. Please make sure you provide enough clearance around all moving parts of the steering rack.
- L.** At this point of the installation the crossmember should be positioned correctly. Remove all non-crossmember parts and MIG weld the crossmember to the frame. For proper installation trim the gauge plates to box in the open inner ends of the spring towers. In order to improve the look of the final installation cap off and trim the crossmember uprights as desired.

5 Trimming the Crossmember

- A.** Install all the suspension components to the crossmember for the front suspension.
- B.** With your car fully assembled including engine and fuel check to make sure the lower control arm is level. Please note you can not test this until the car is complete and fully assembled with correct curb weight.
- C.** Align your vehicle with the following specifications
- Caster :: 1 degree positive
 - Camber :: 1/2 degree positive
 - Toe-in :: 1/8"
- D.** Recheck your welds, bolt torques, caster, camber, and toe-in after 100 to 200 miles of travel. At this point in time your springs should have settled down, resulting in the lower control arm being parallel to the ground. In the event you car is sitting too high you may need to purchase Helix's softer springs, or cut the springs as needed to achieve desired ride height.

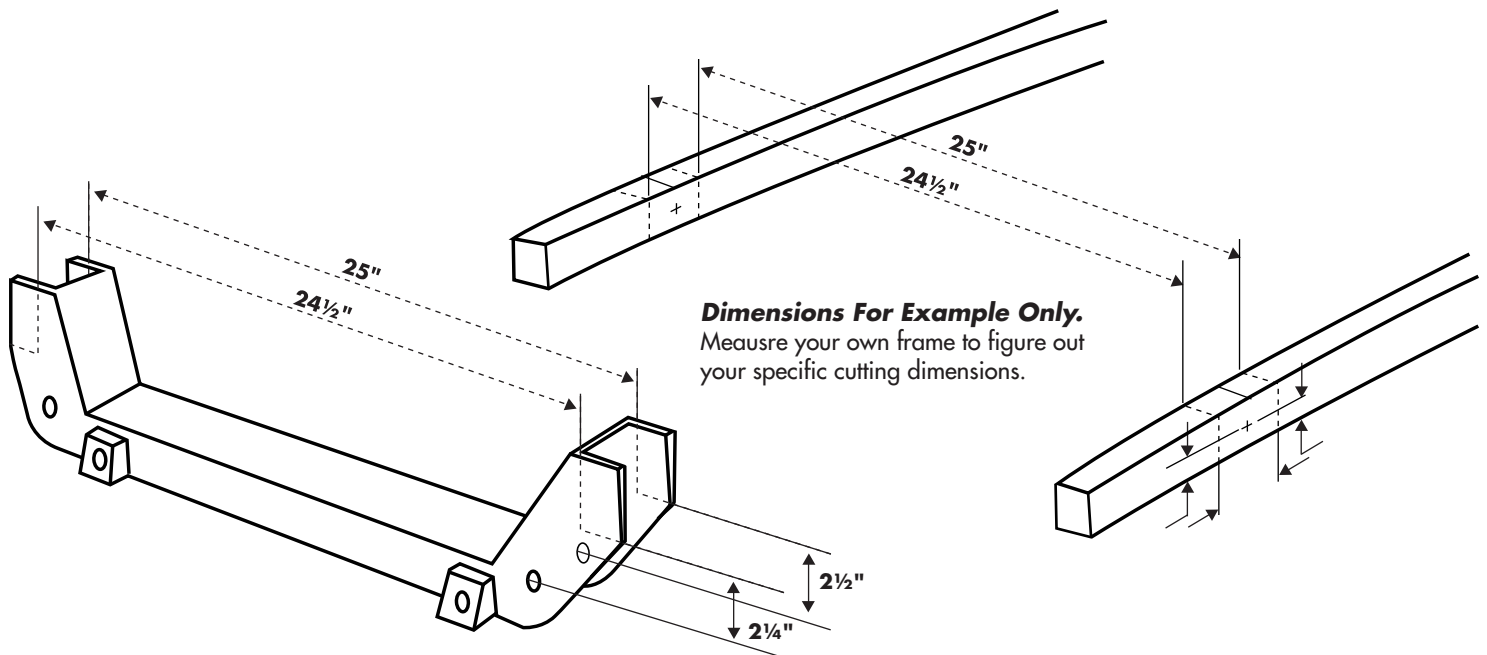
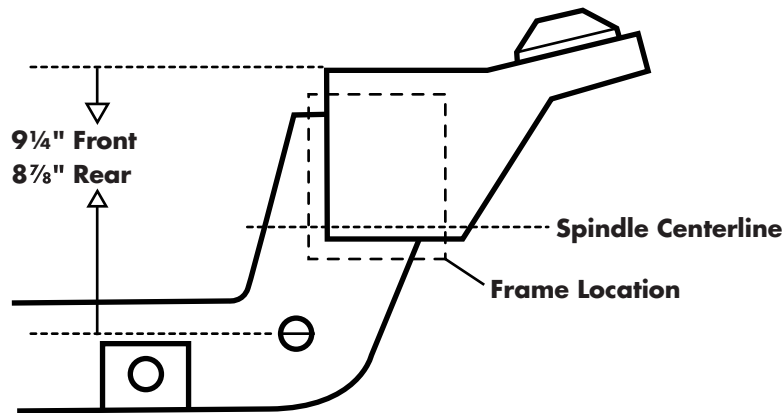

User Guide & Installation Manual Mustang II IFS



Part Number	Track Width	Spring Tower Position
M2U	56.5"	33.5"
M2W	58.5"	35.5"
M2X	60.5"	37.5"

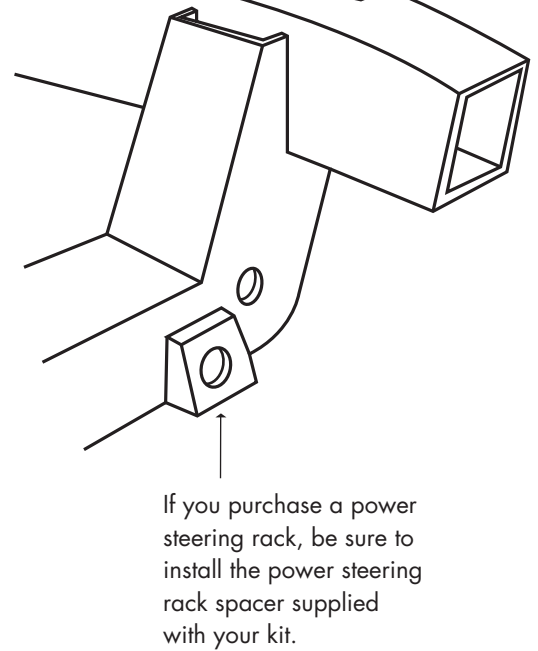
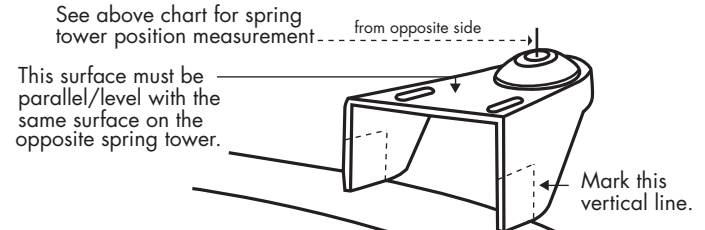
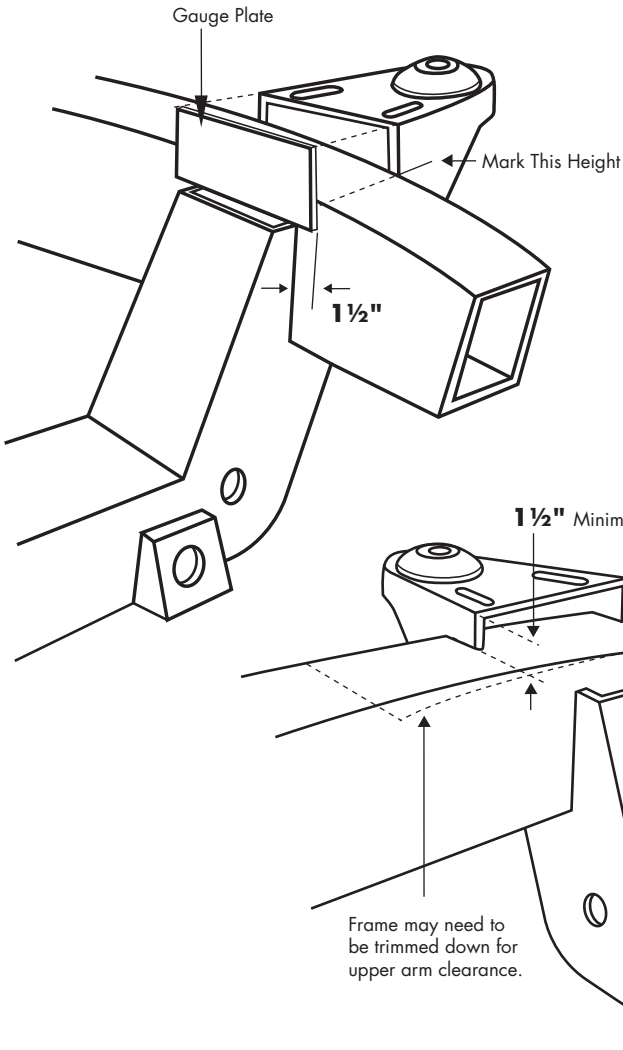

Shock Absorber Notes:

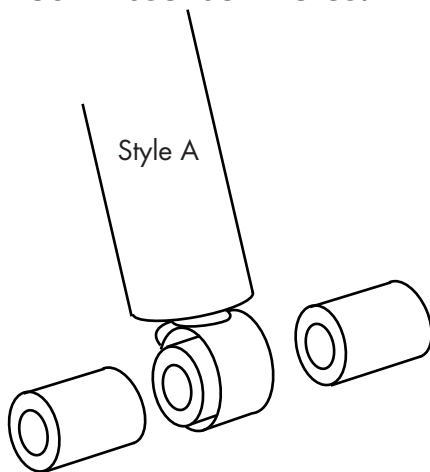

If your kit came with Style A, be sure to use spacers on either side of lower shock mounting hole.
If your kit came with style B, drill out lower mounting hole to accept larger, reinforced lower shock bolt to 1/2".

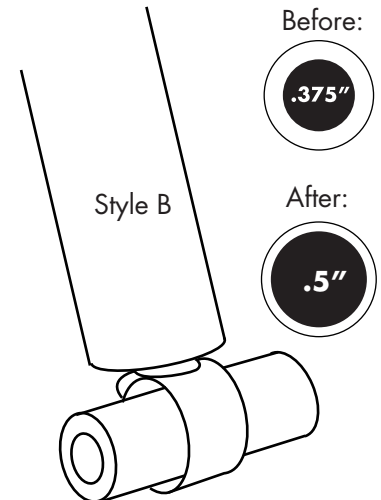

NOTE: In the event the rotor contacts the bracket, simply grind off surplus casting material for needed clearance.

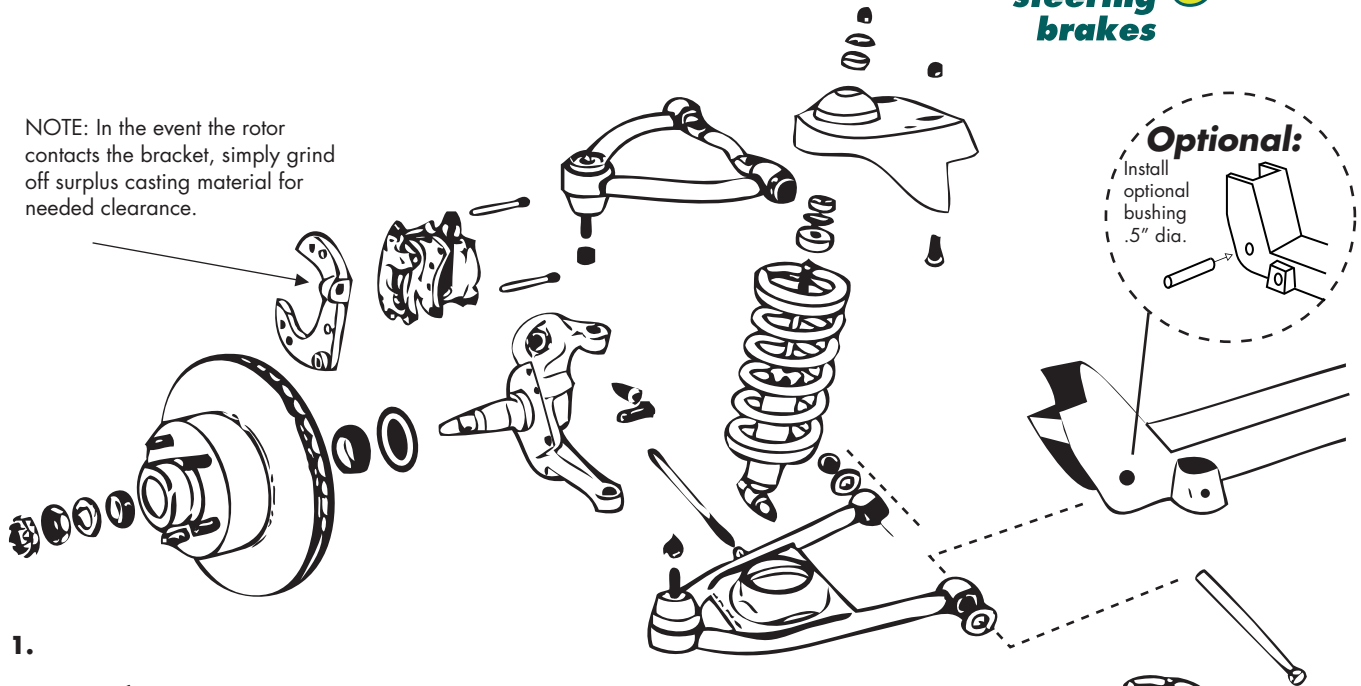

1.

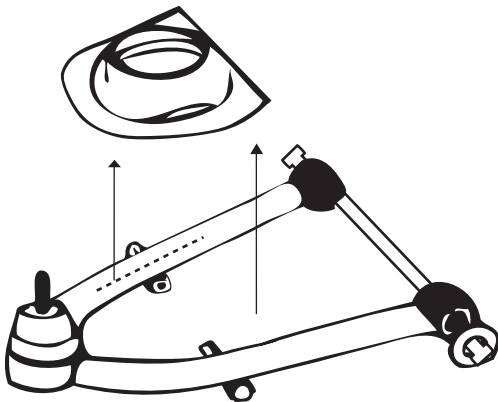

Optional Coilover & AirBag Procedure

1. Before cutting out the plate, replace the bolt and nut in the arm to retain the shape of the arm. Do not remove the bolt until the new plate has been welded. Cut lower spring landing along welds without damaging tubular control arm and remove. Grind smooth and paint.

2A. Use the two spacers on either side of the coilover lower mount when mounting into the lower control arm.

2B. Stitch weld the airbag bracket onto the lower A-arm using 1" welds. Let the arm cool between welds.

3. Install the air bag top hat. For any air bag/air shock kit, the top spring mount on the top hat must be removed.

2A.

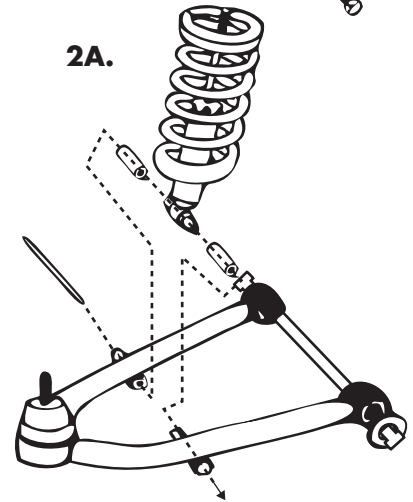

2B.

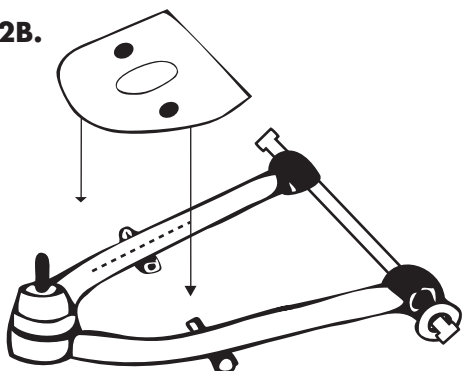

3.

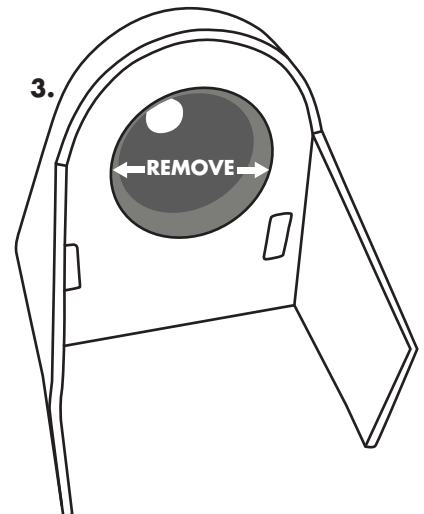

COIL OVER ASSEMBLY & ADJUSTMENT

INCLUDED:

- HEXSHX1273 x2
- HEXSHXA1 x2
- HEXSHXA2 x2
- HEXSHXB1 x2
- HEXSPR64230350A x1



1

Grab the shock (HEXSHX1273) and the shock adapter (HEXSHXA1). Insert shock adapter over the shock as shown in the picture below. Make sure that the side that has the lip on the inside goes in first.



2

It should look like this.



3

Next attach loop shock adapter (HEXSHXB1) like shown below.



4

After that you will put the bushing eye adapter (HEXSHXA3) on, as shown below.



5

Now you will attach the Spike stem shock adapter (HEXSHXB2) to the end of the shock as shown below.



6

Finally you will put the Spring (HEXSPR3) on the shock. Make sure the smaller end goes down first as shown below.



7

Now repeat for the other side.

NOTE: Use Loctite (or similar thread adhesive) to secure all threaded parts (excluding coil over locking ring).



DETERMINING SPLINE SIZE

To determine the spline size of a component (rack and pinion, steering column and steering box), measure the outside diameter and count the number of splines. If there is a flat spot on the shaft and some of the spline are missing, count halfway around where there are splines and double that number. We need to know how many teeth are in a theoretical full circle.

- Available U-joint combination are:
- A) Smooth bore on both ends
 - B) Smooth bore and Spline or Double D
 - C.) Spine and/or Double D on each end

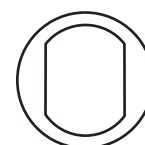
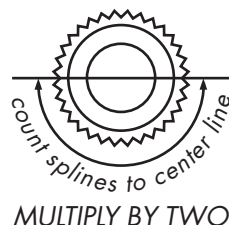

Double D (DD)

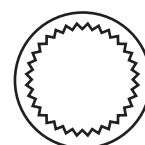

Splined (SP)

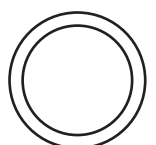

Smooth (S)