

PART LIST

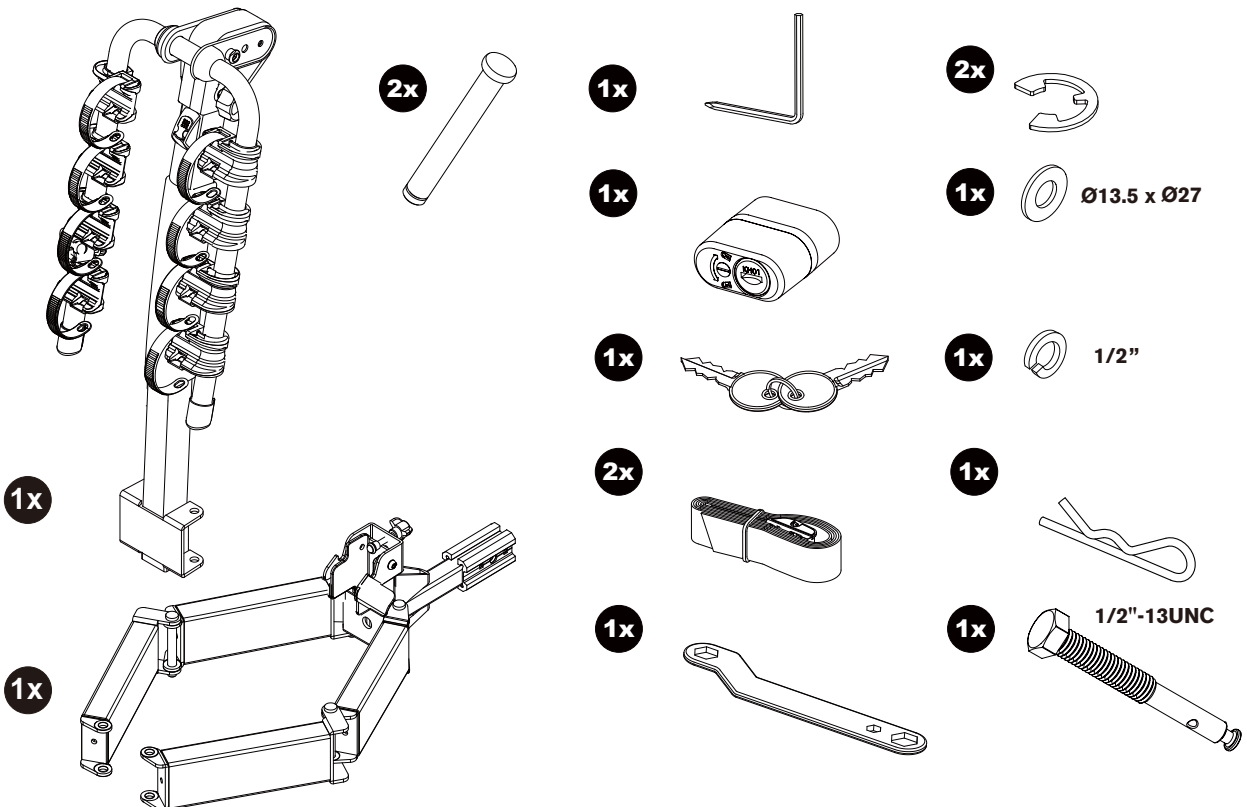



glideAWAY®

Advantage
SportsRack

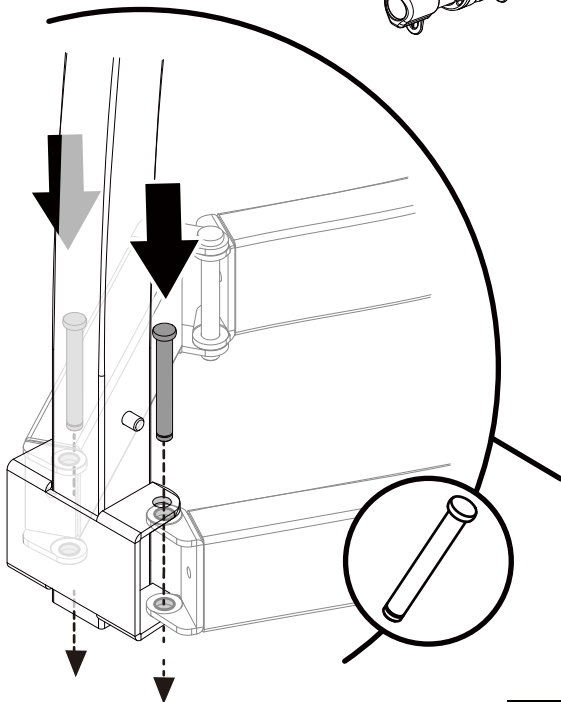
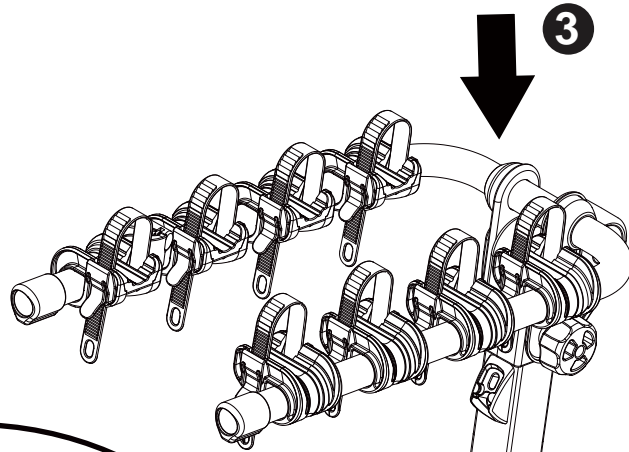
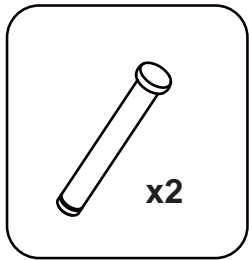
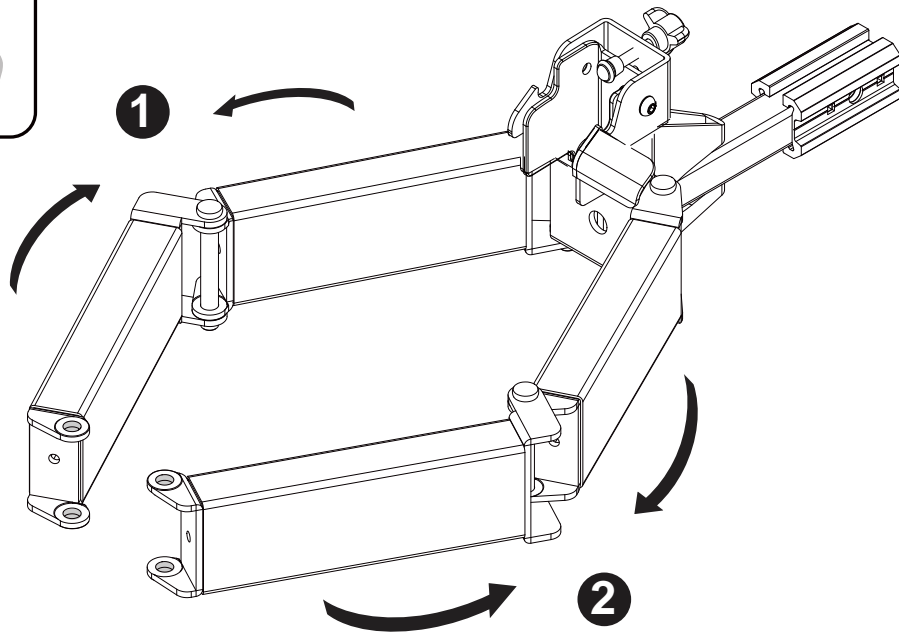

2

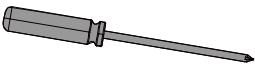
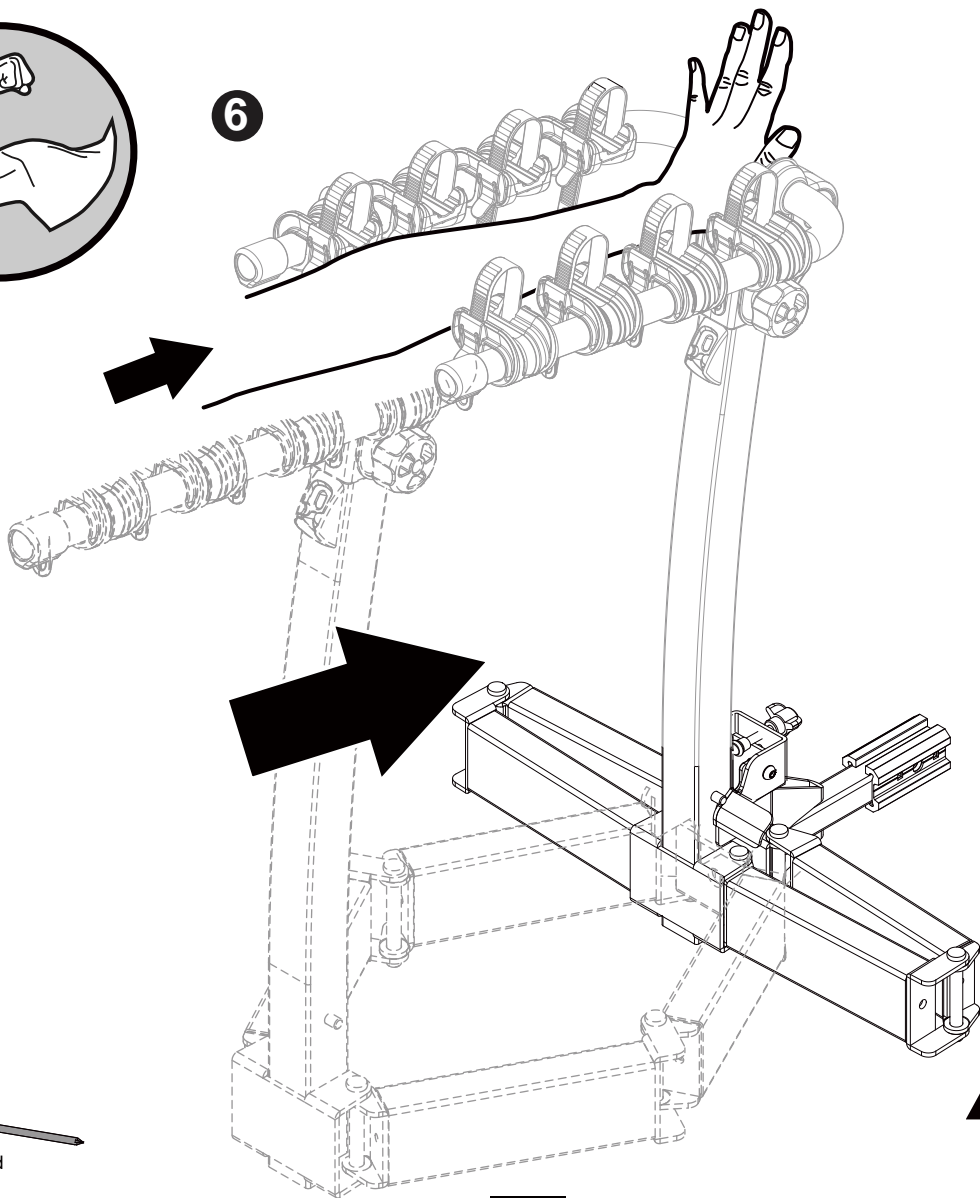
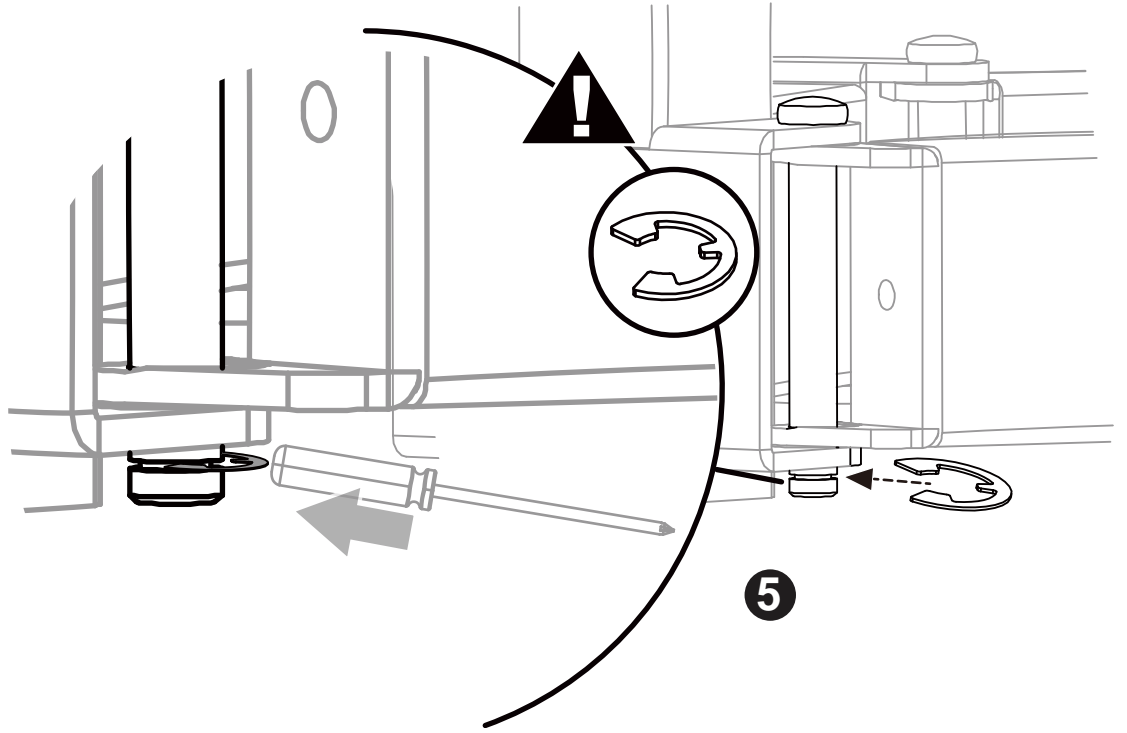
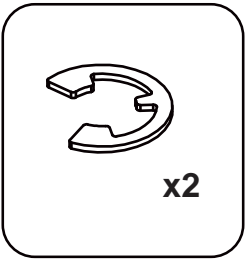

Tool Not Included

3

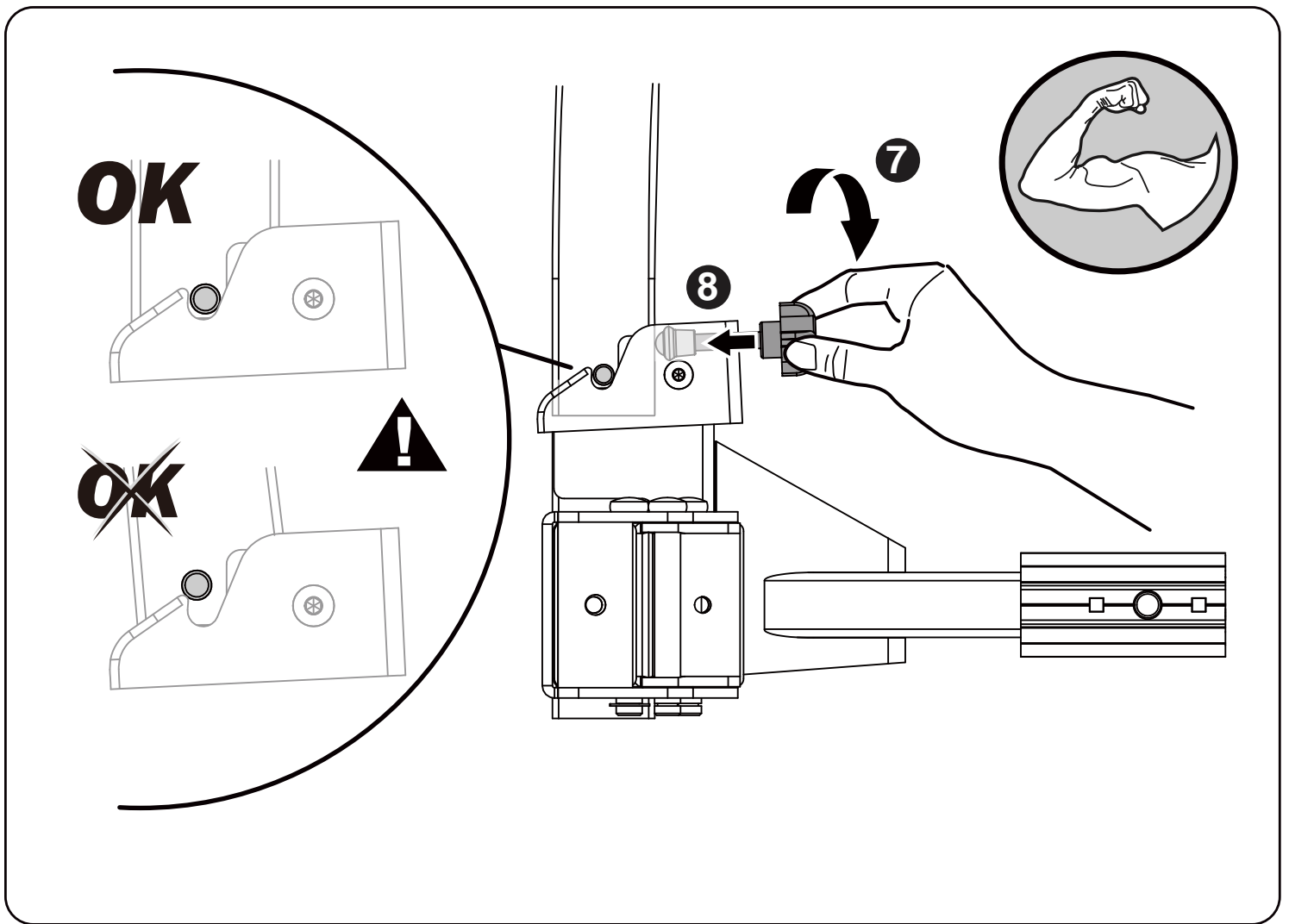

CARE AND MAINTENANCE

- As an extra precaution, we recommend you double check the hitch bolt and all glideAWAY fasteners once a month (and every time you reinstall it, whichever is more often) to ensure everything is securely fastened and attached correctly. Address anything that has loosened or shifted over time with vehicle/road vibration.
- When not in use but on the vehicle, lower arms and remove straps to avoid decay from ultraviolet rays.
- For proper operating performance, we recommend you clean your glideAWAY from time to time with soap and water, to ensure salt, sand, grit and other debris do not interfere with glideAWAY's smooth operation. In more winterized-salty conditions, wash the glideAWAY thoroughly after every use.
- Please remember to remove your glideAWAY if you drive through an automated car wash.
- Routine lubrication of glideAWAY is required around the T-handle shaft to  ensure the knob lifts easily and the platform rotates with ease. Use 3-In-One® Oil generously and often.

For more information on 3-In-One Oil, please visit www.3inone.com **3-IN-ONE**.
 Please share & show your use of the glideAWAY by uploading photo/comments onto the Advantage Facebook page.

This is a set of Warnings that should also be applied to these instructions:



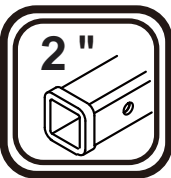

- WARNING! - DO NOT USE ON A TRAVEL TRAILER, 5TH WHEEL, OR TOWED VEHICLE
- WARNING! - DO NOT DRIVE OFF-ROAD WITH RACK/BIKES ATTACHED, IT COULD RESULT IN DAMAGE TO VEHICLE, RACK AND BIKES
- WARNING! - USE CAUTION WHEN ENTERING STEEP DRIVEWAYS AND GOING OVER SPEED BUMPS
- WARNING! - NOT INTENDED or DESIGNED FOR ELECTRIC, MOTORIZED, TANDEM OR RECUMBENT BICYCLES

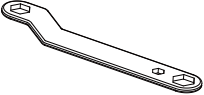

glideAWAY®

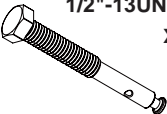
Advantage
SportsRack

- 
- 

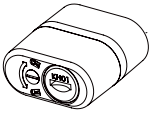
-  1/2"-13UNC x1
-  Ø13.5 x Ø27 x1
-  1/2" x1
-  x1
-  x1
-  x1

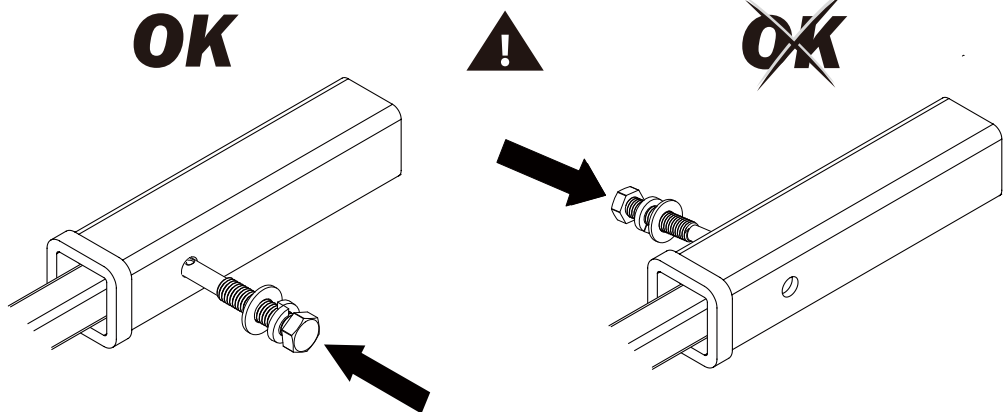
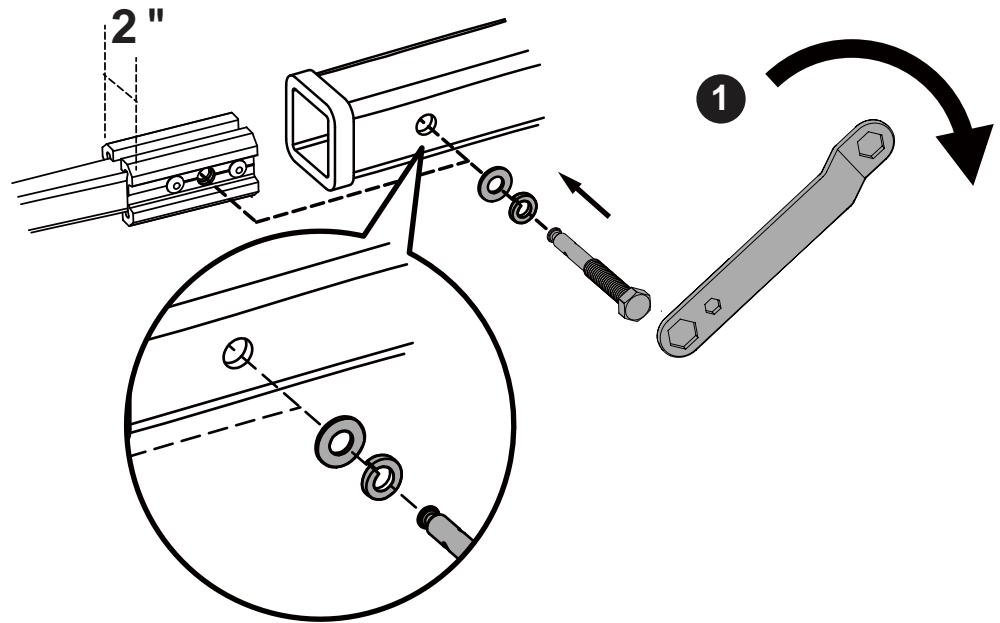

option 1

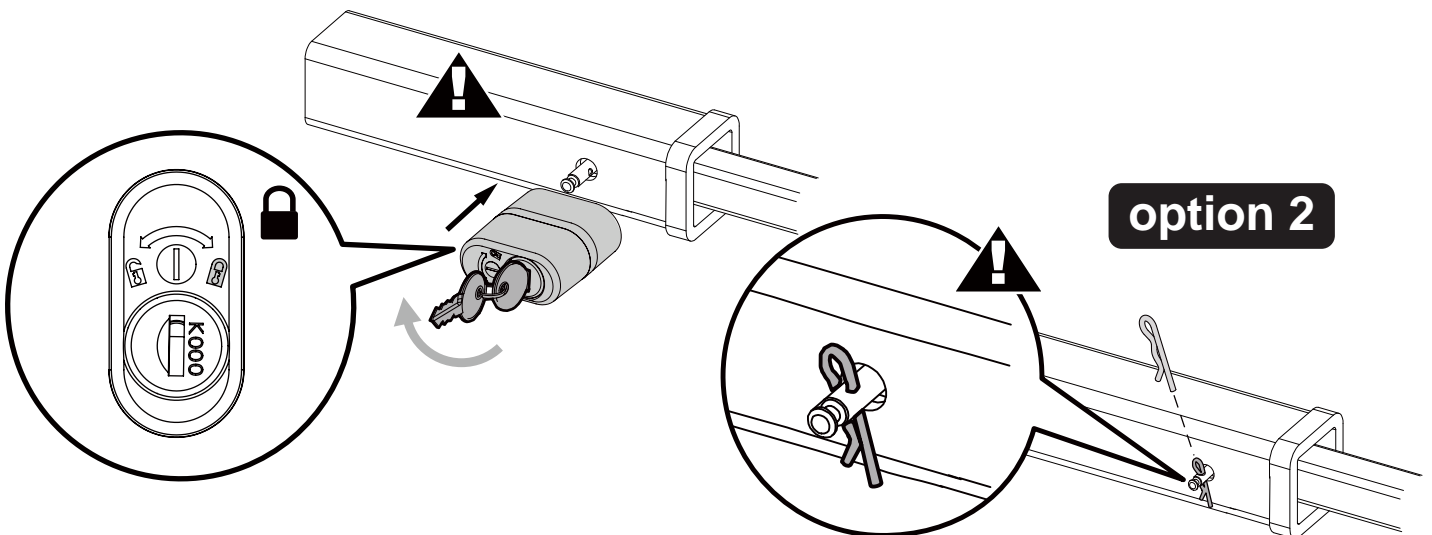



glideAWAY®

Advantage
SportsRack

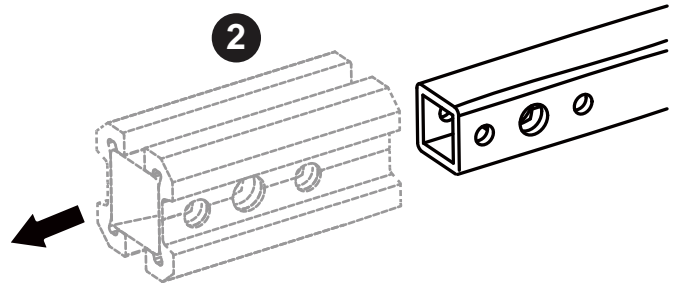
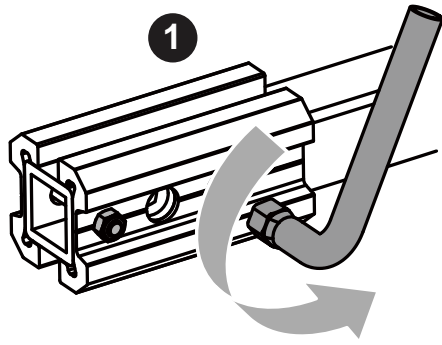

1 1/4"

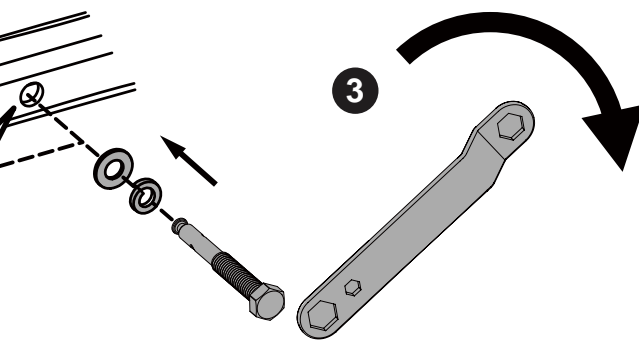
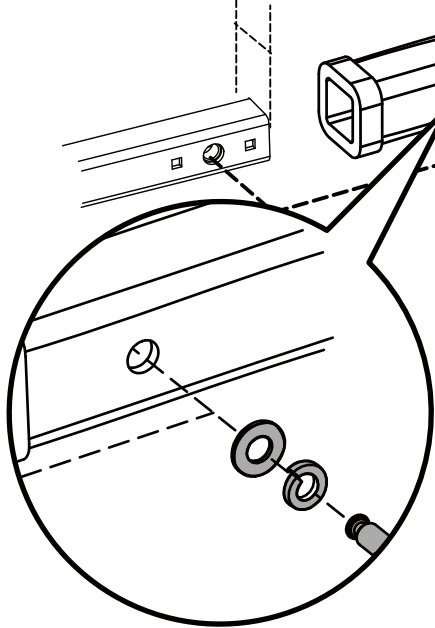

OK



~~OK~~

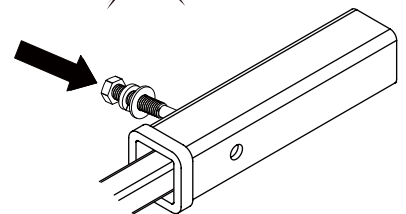
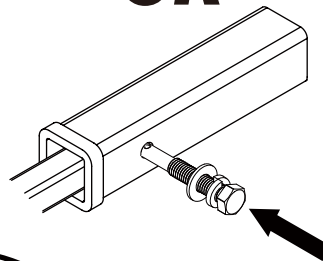

option 1

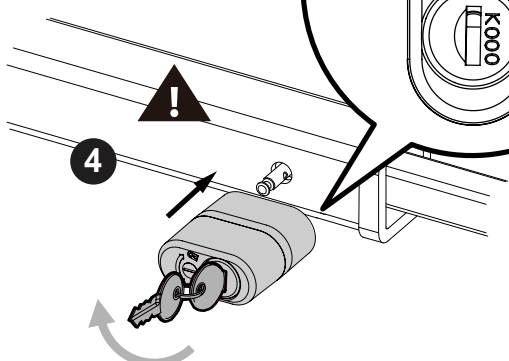
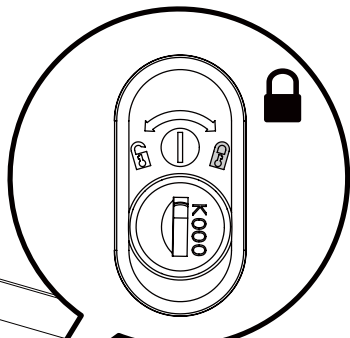

option 2

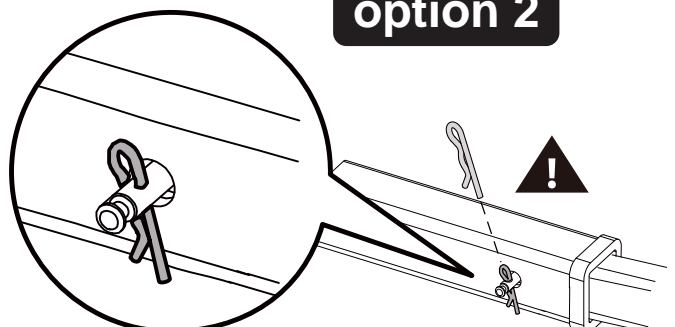

6

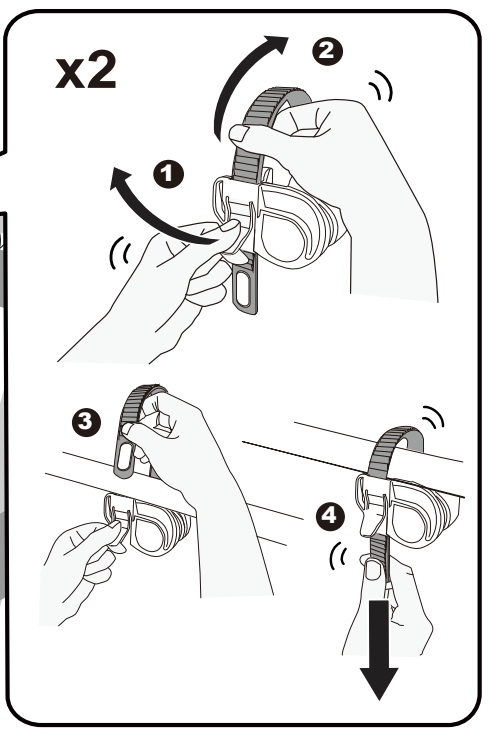
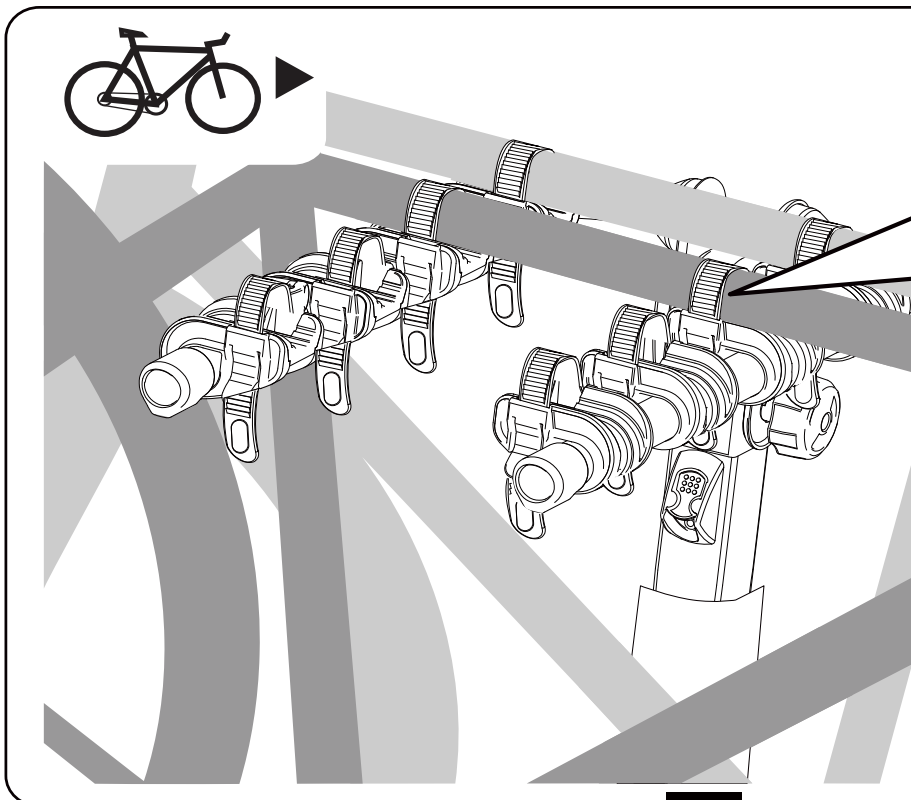
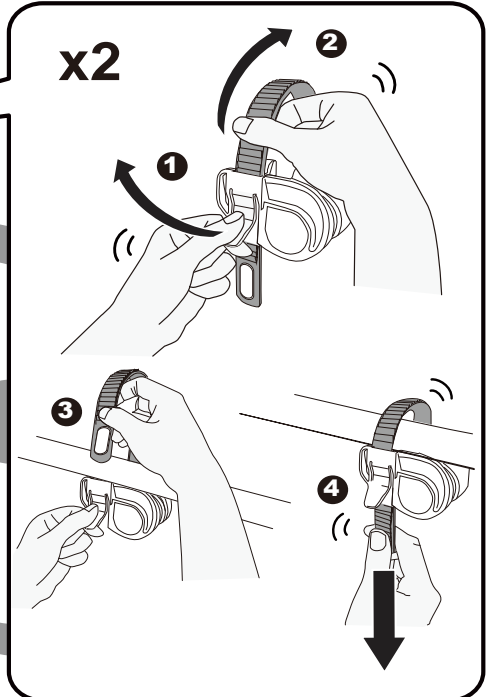
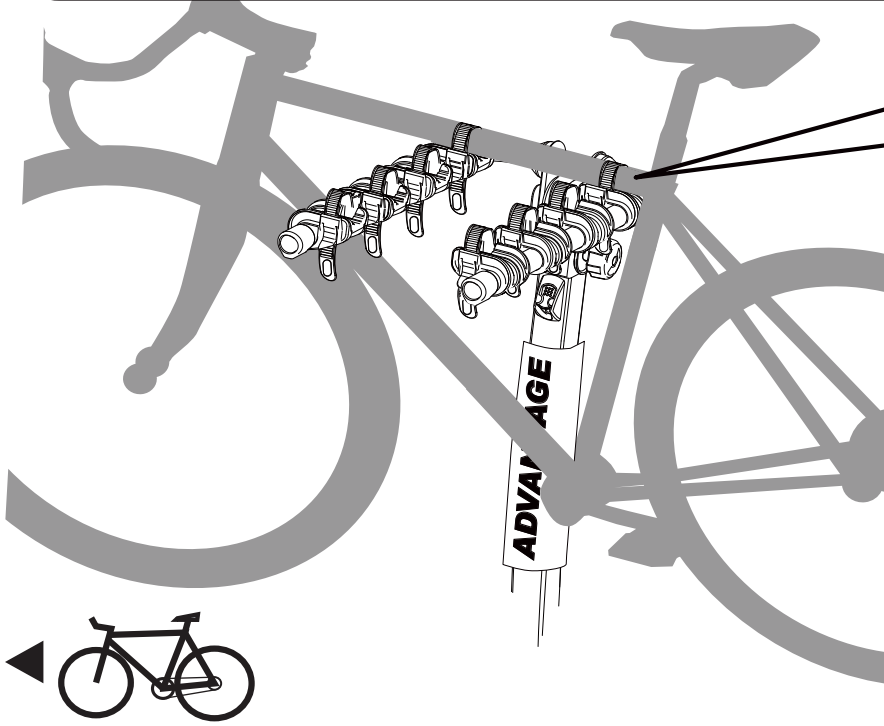
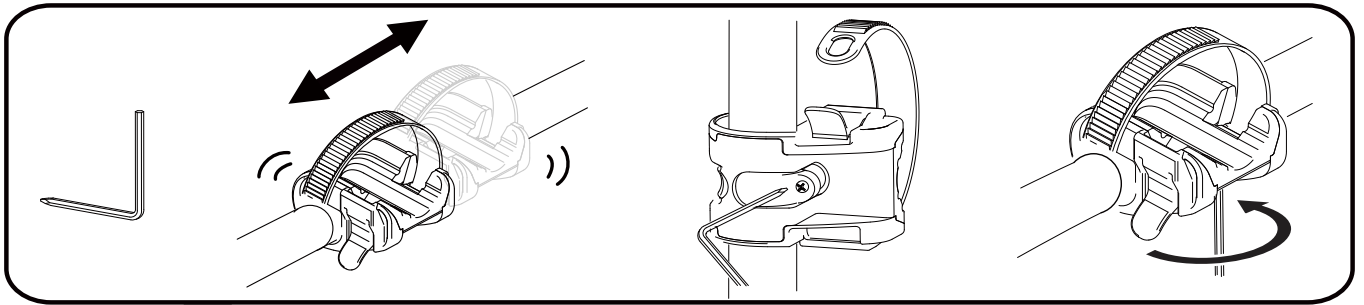

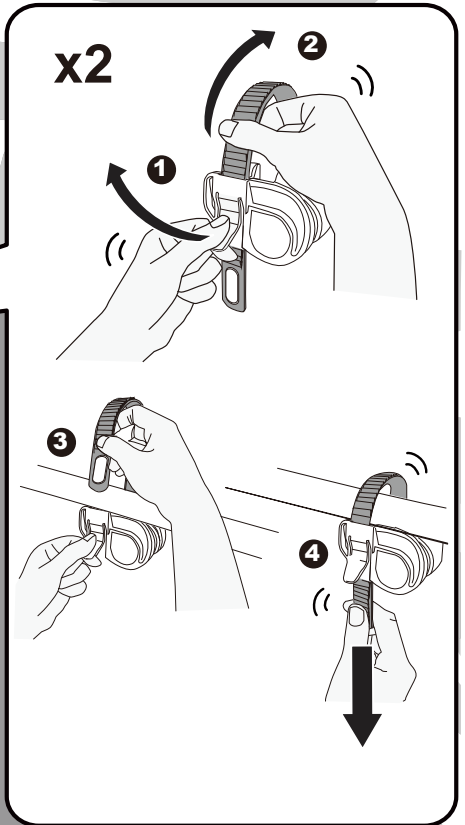
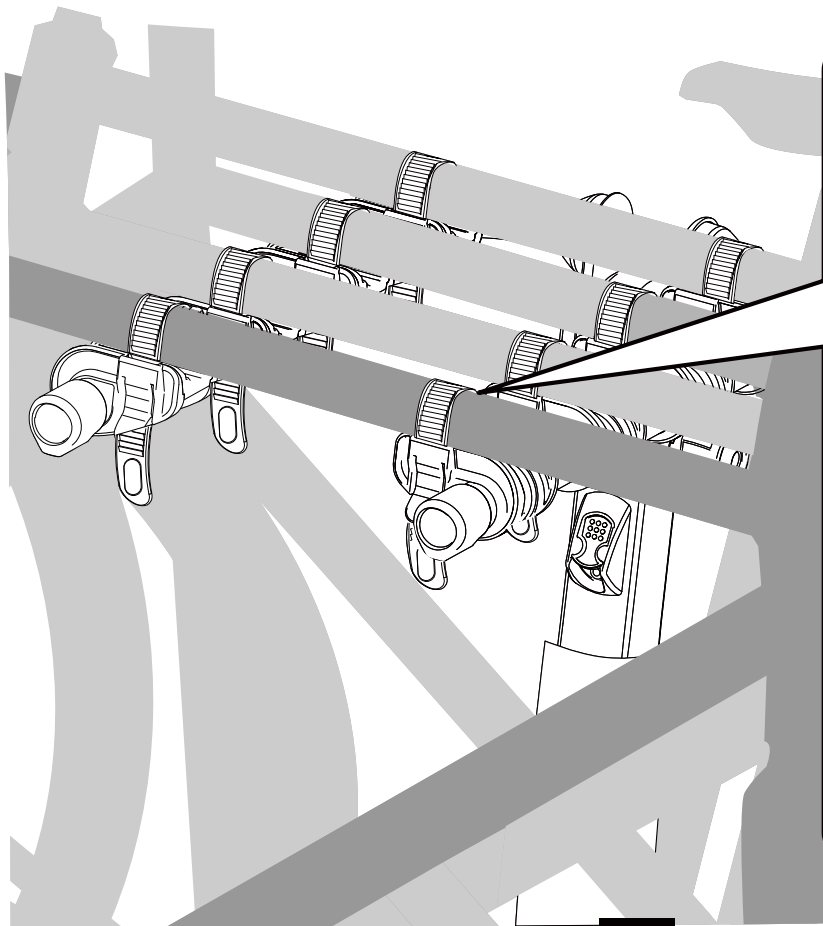
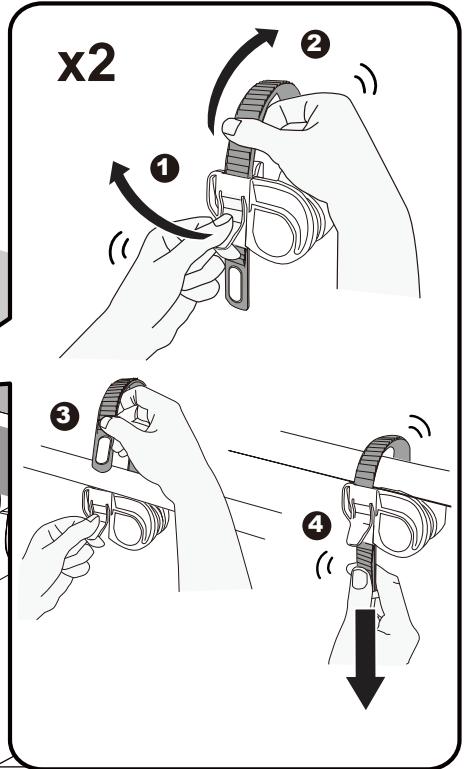
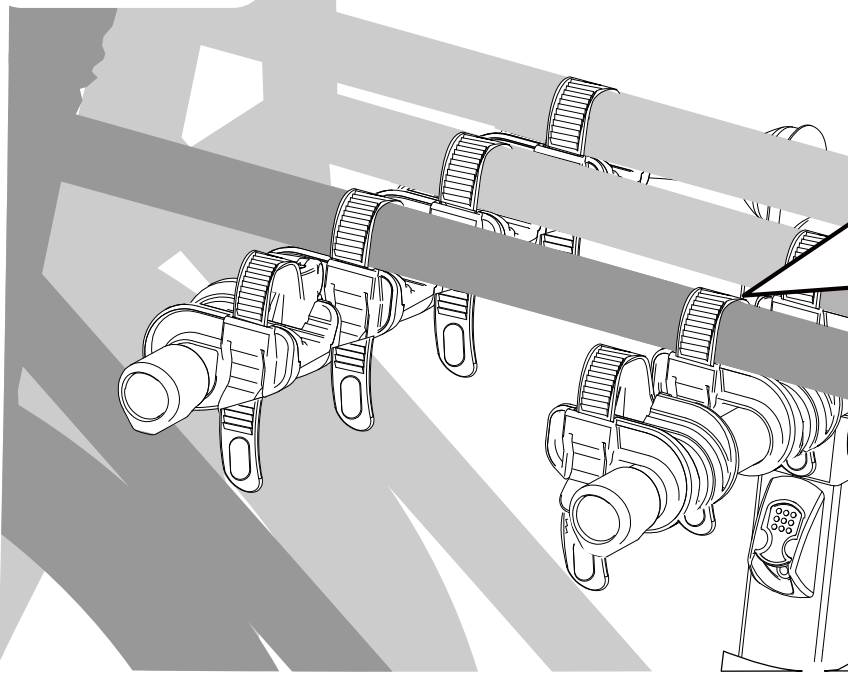

OK

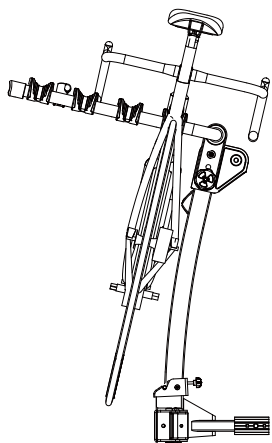

OK

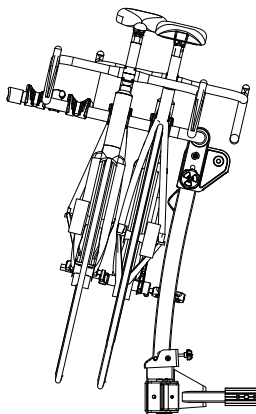

OK

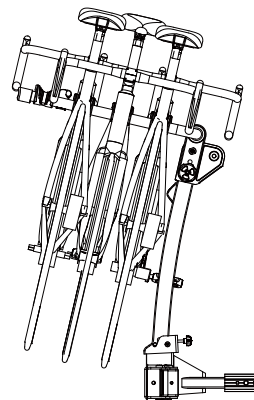

~~**OK**~~

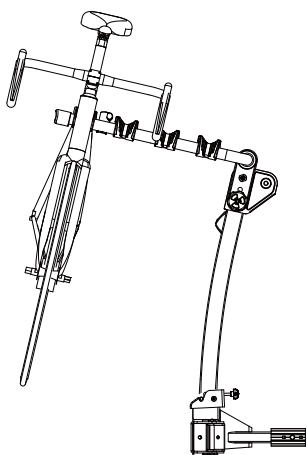

~~**OK**~~

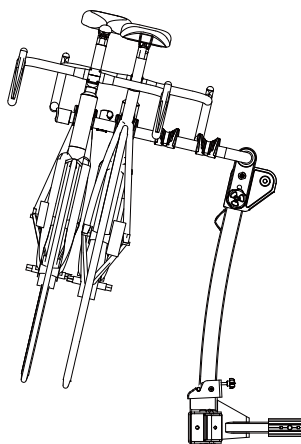

~~**OK**~~

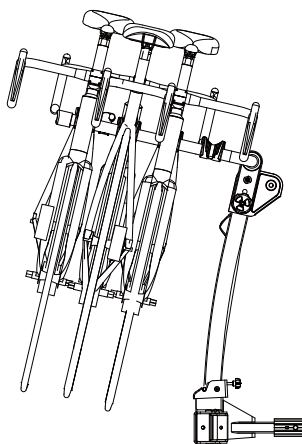

1  = 1x15kg MAX

2  = 2x15kg MAX

3  = 3x15kg MAX

4  = 4x15kg MAX

Max load 123 lbs/60kg

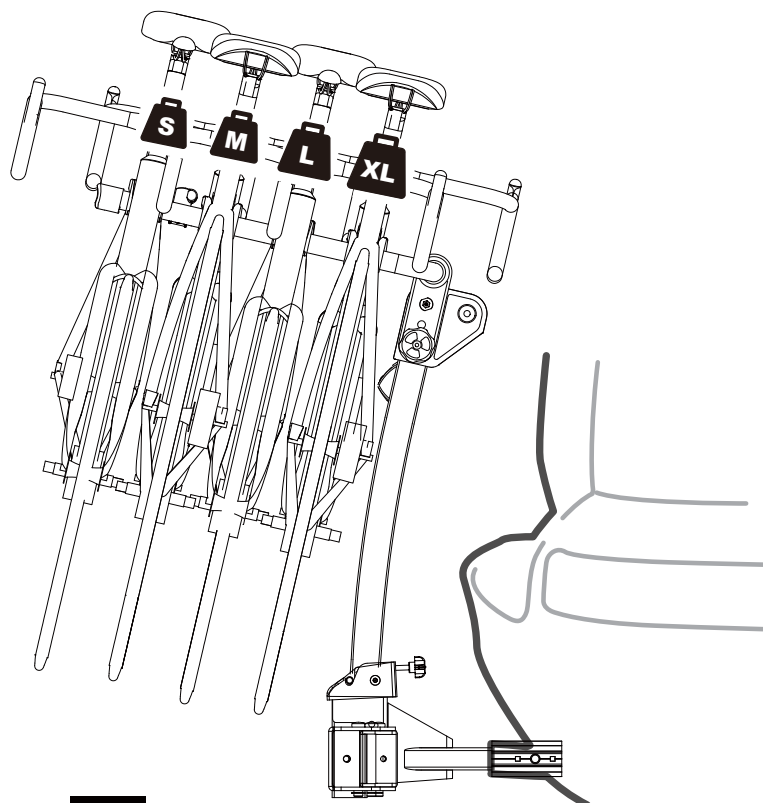

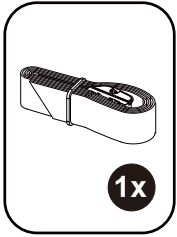

XL

L

M

S

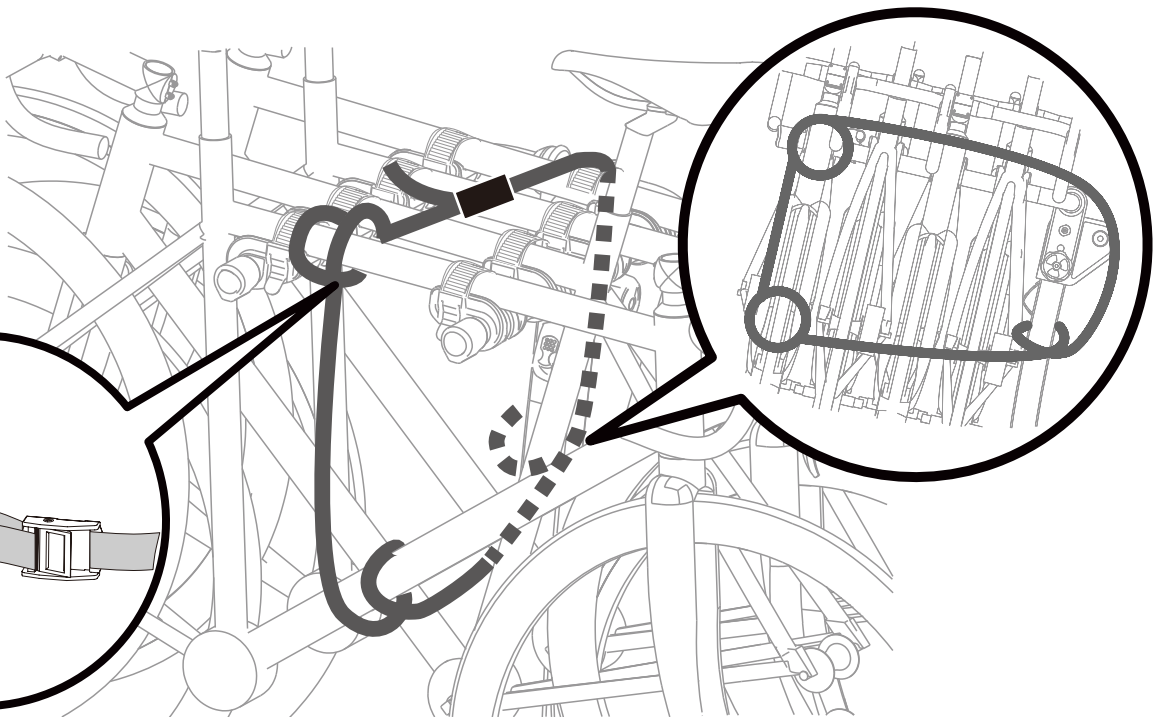
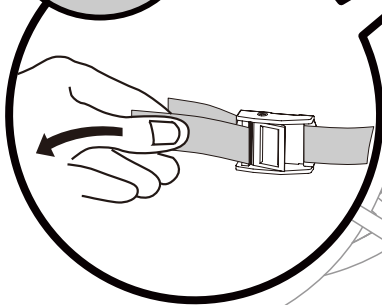
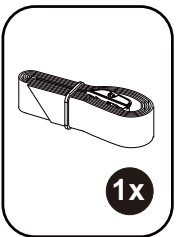
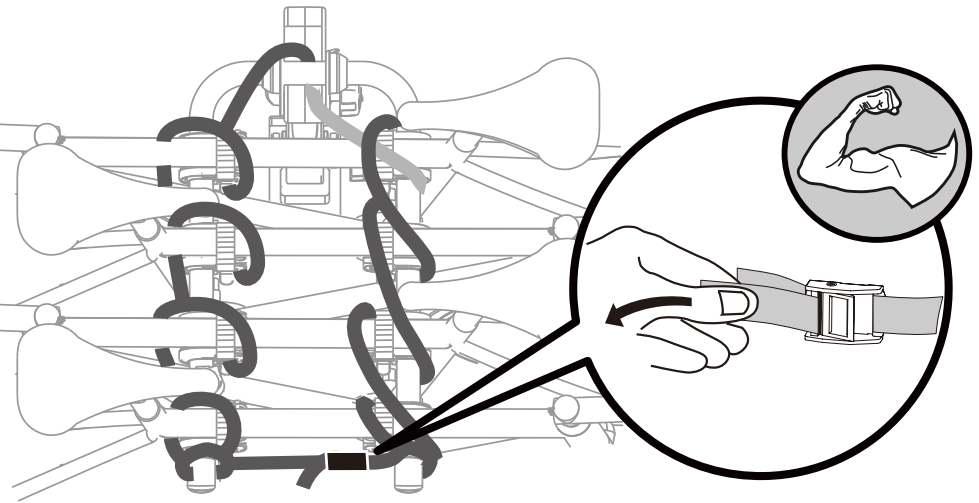

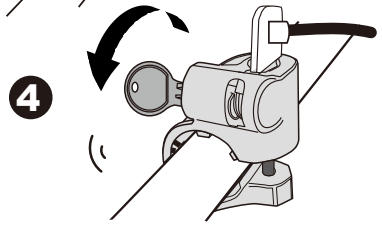
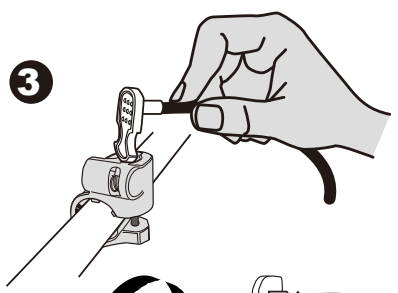

CLICK

x1

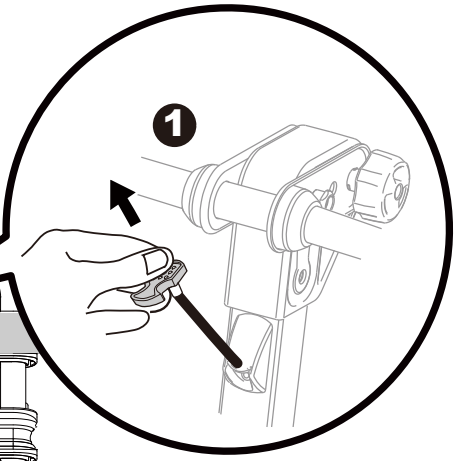
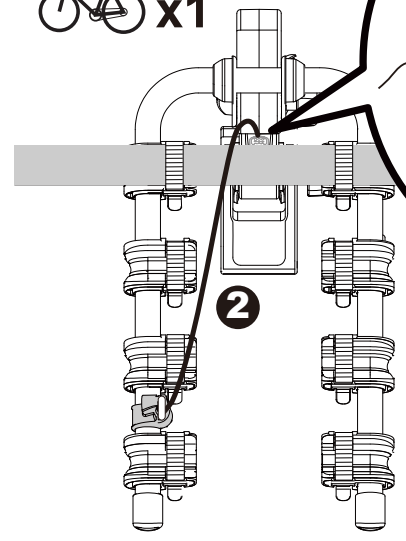

2

x2

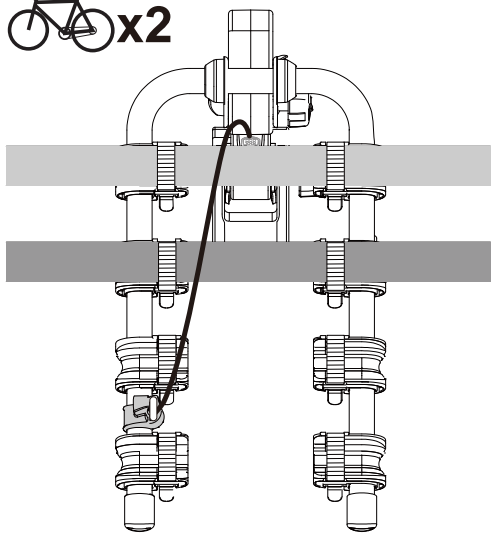

x3

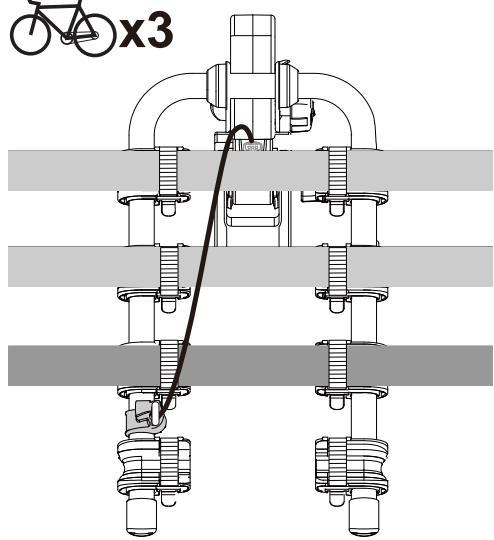

x4

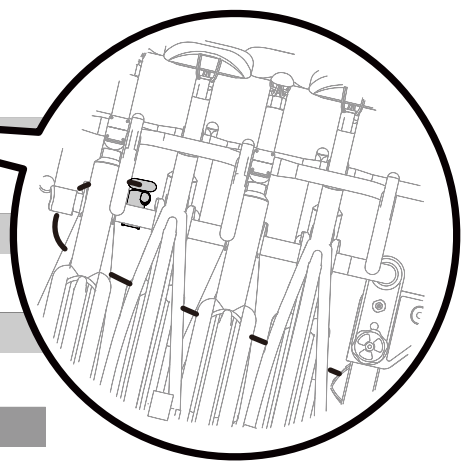
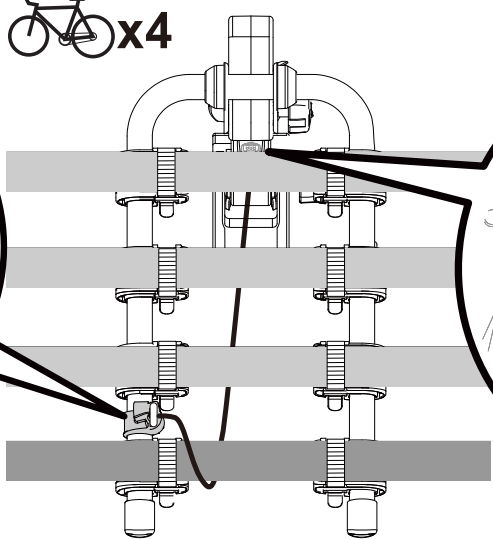
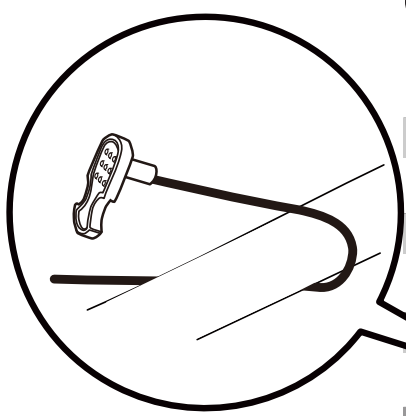

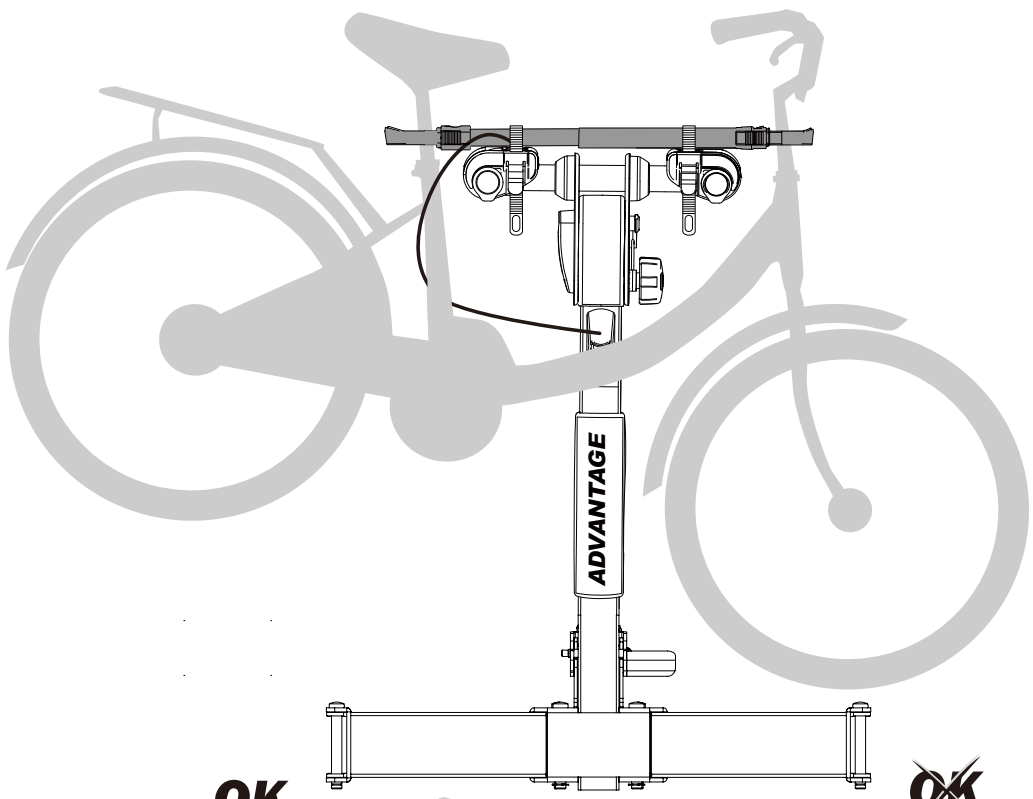
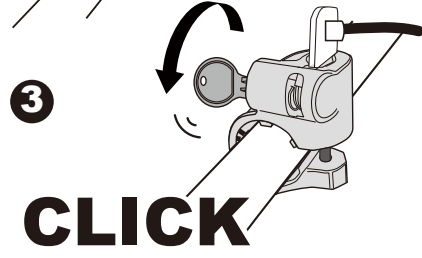
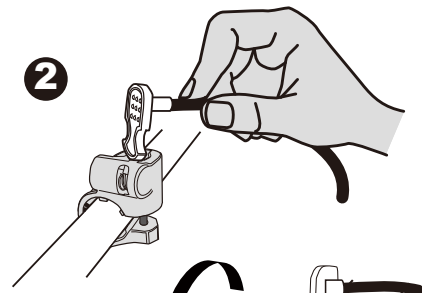
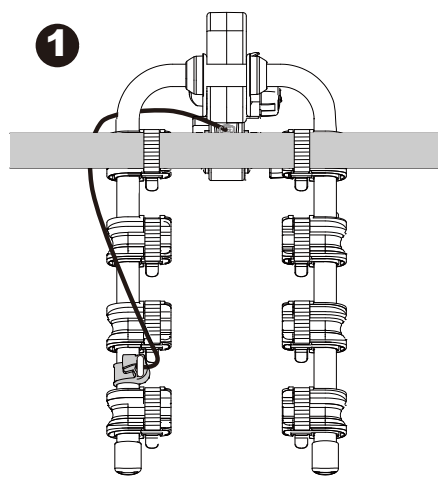
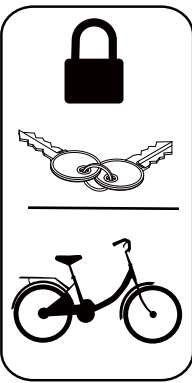

OK

~~**OK**~~

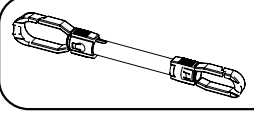
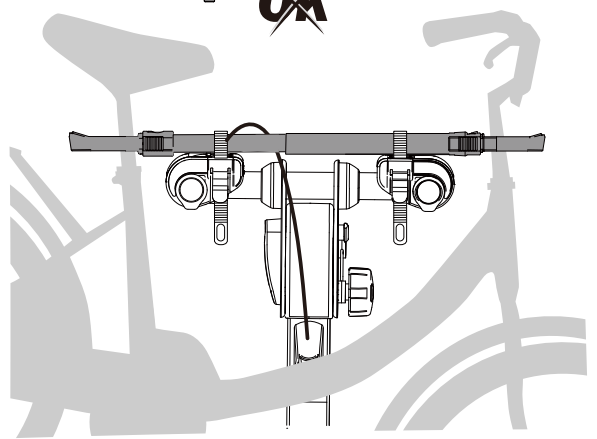
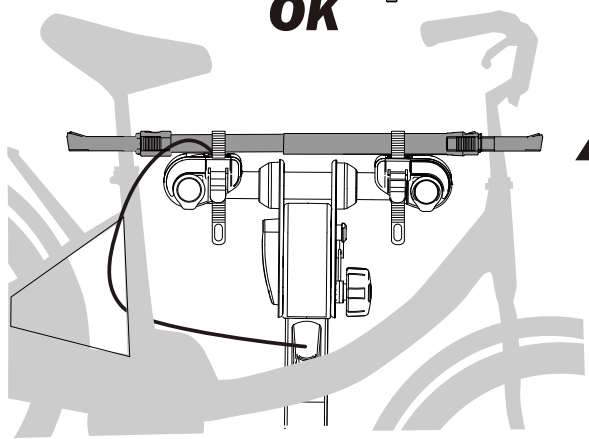

Adapter is not included
Sold Separately, Heinger
Item No.#6009

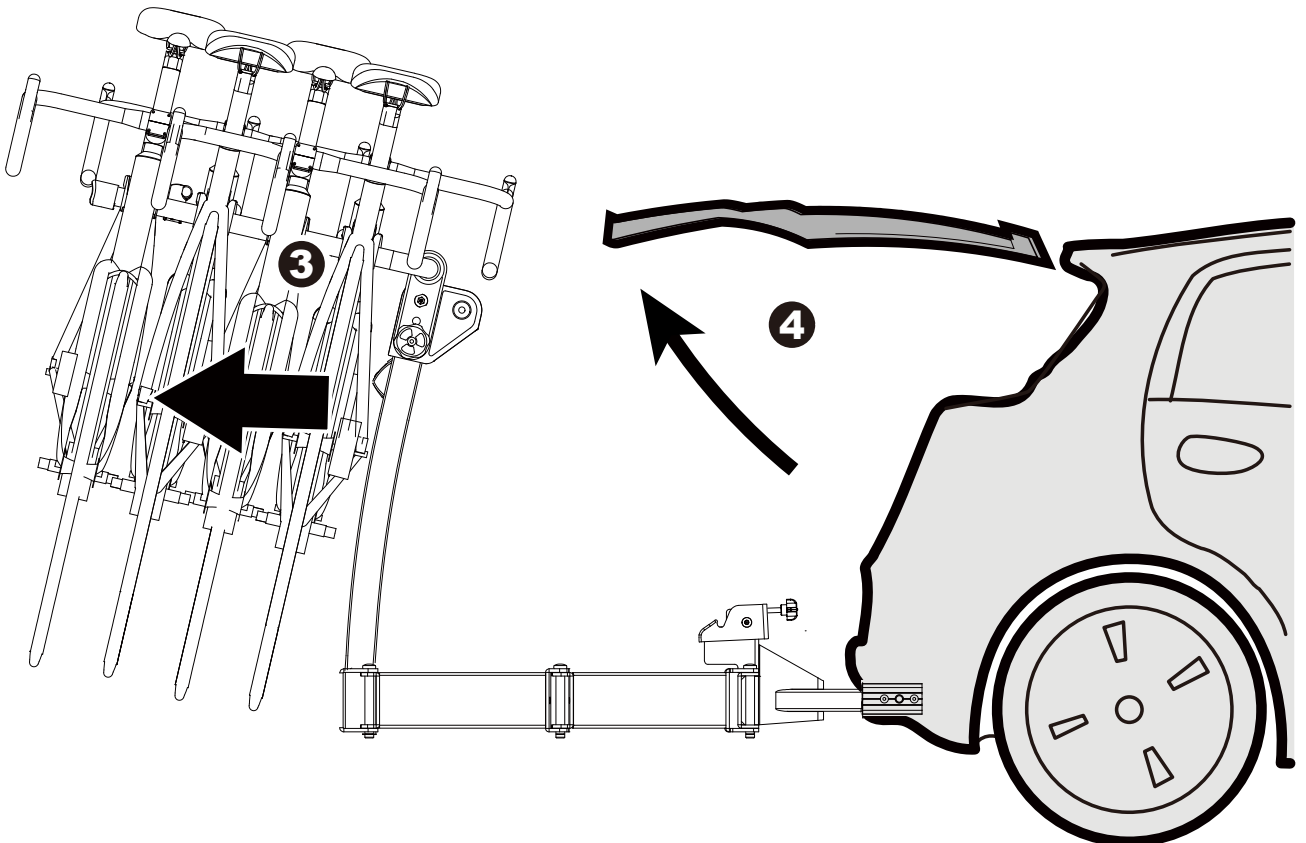
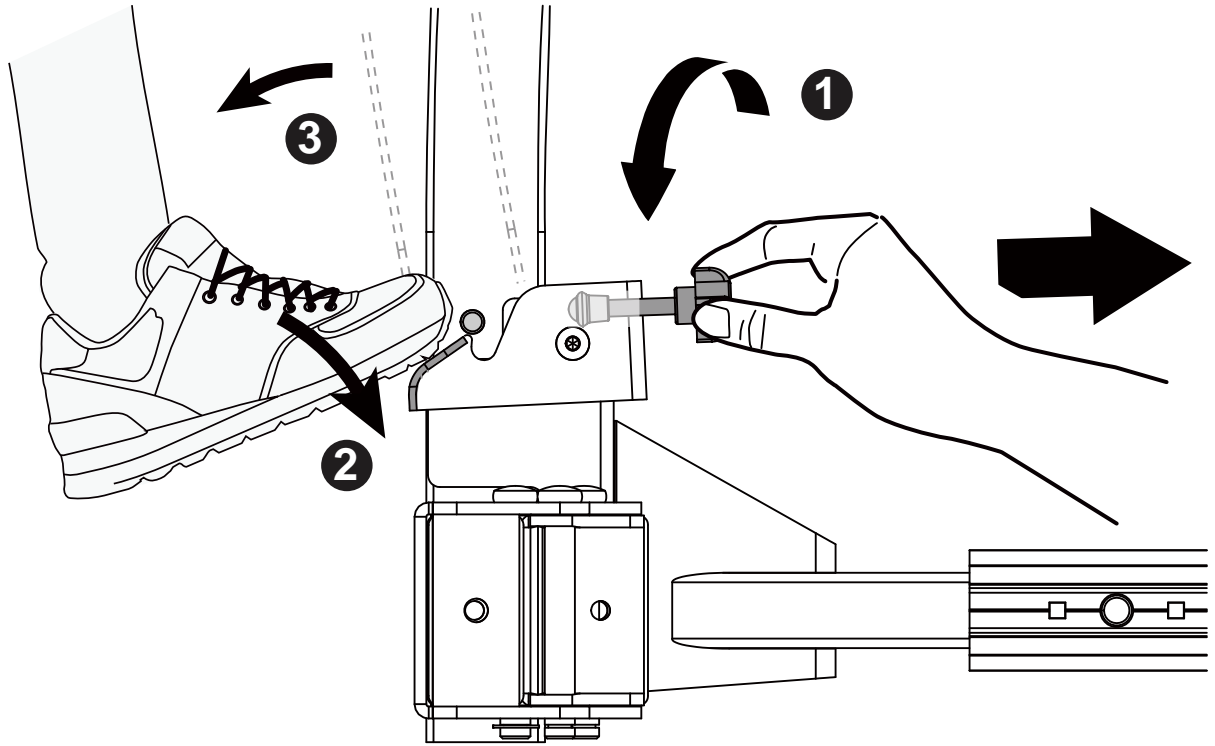

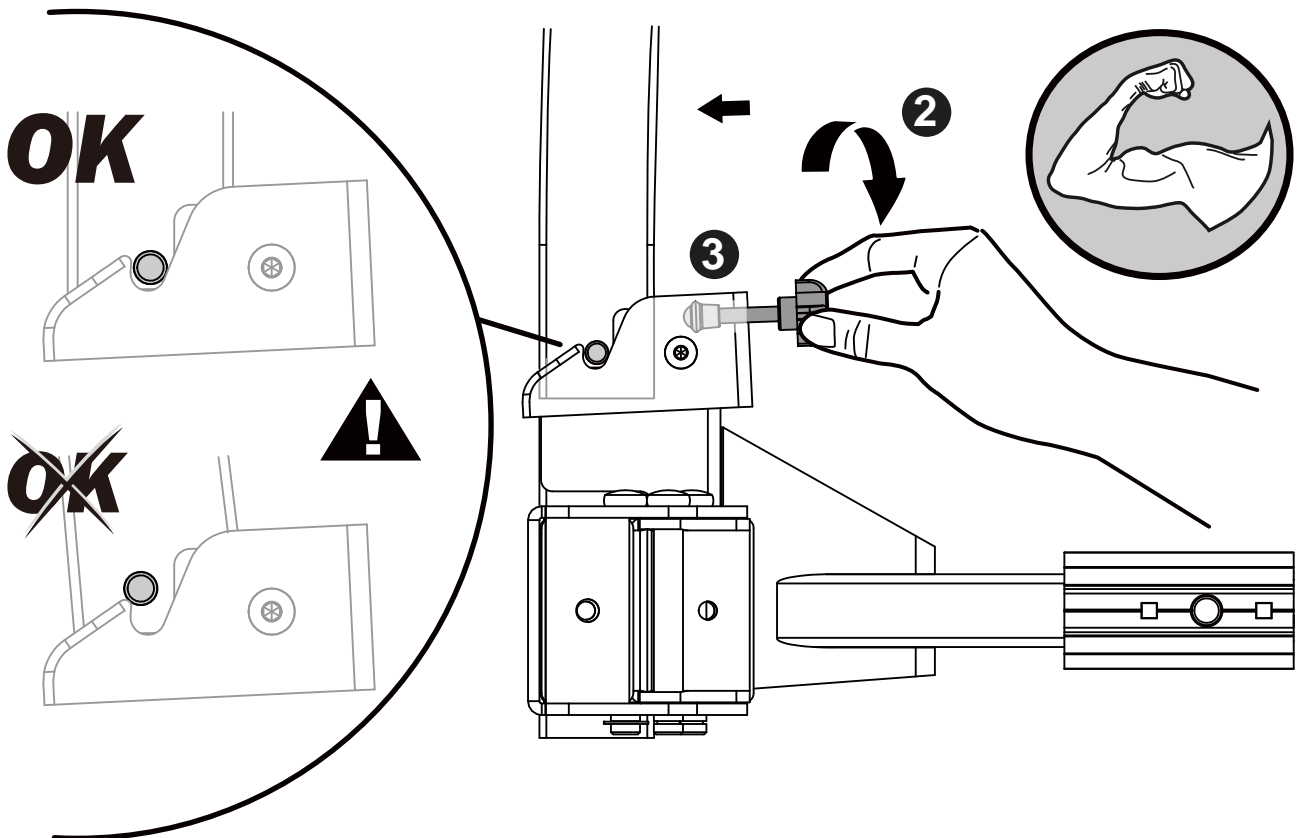
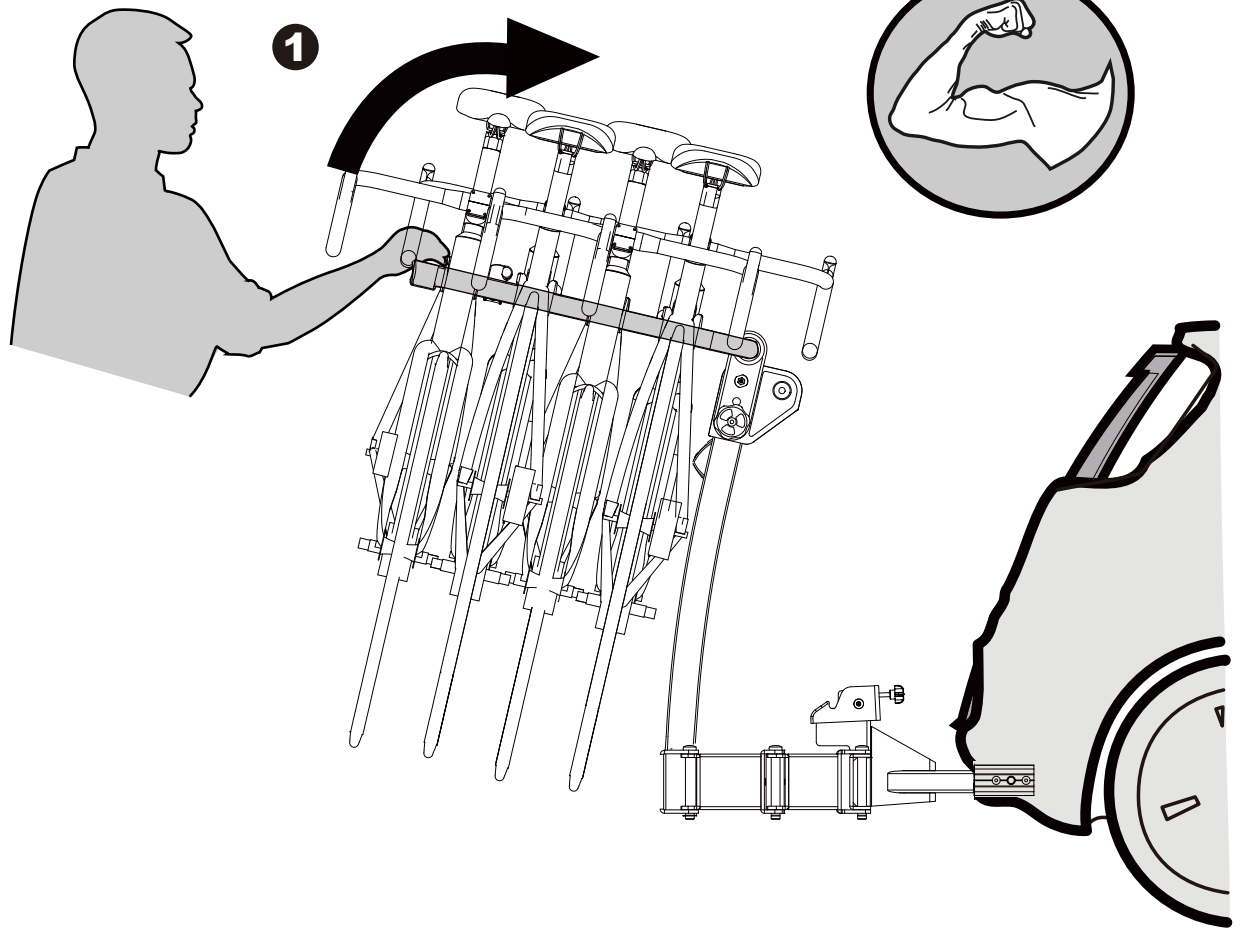

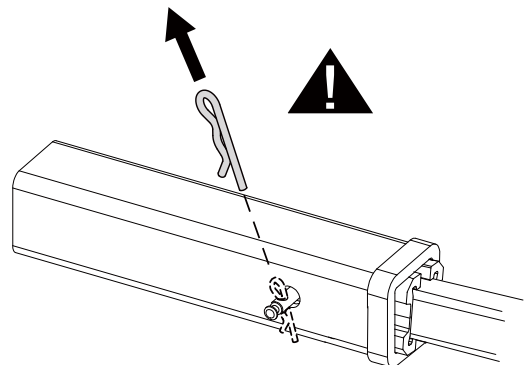
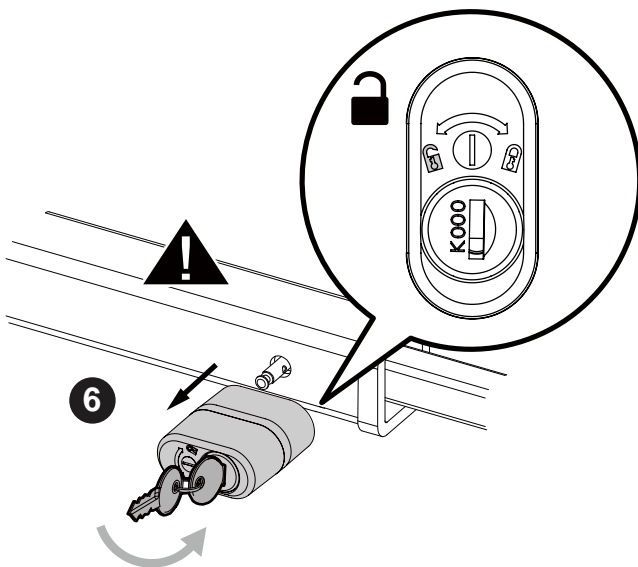
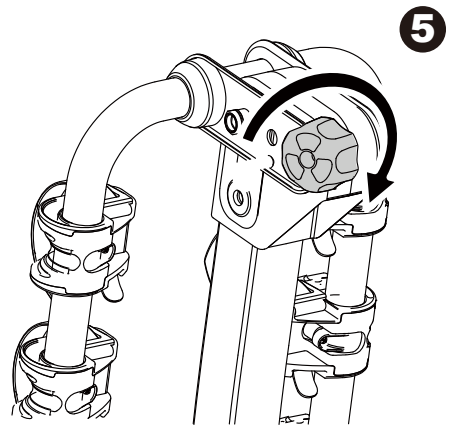
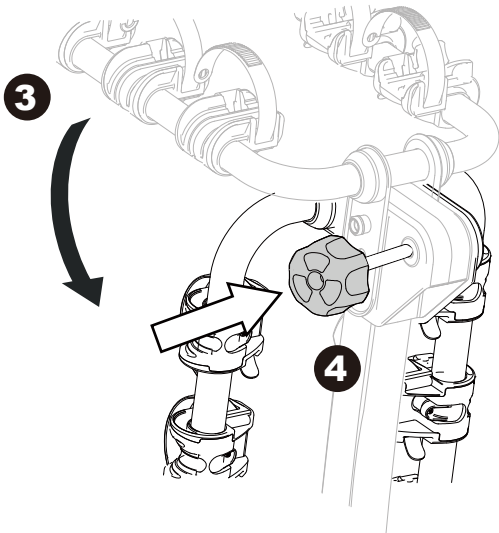
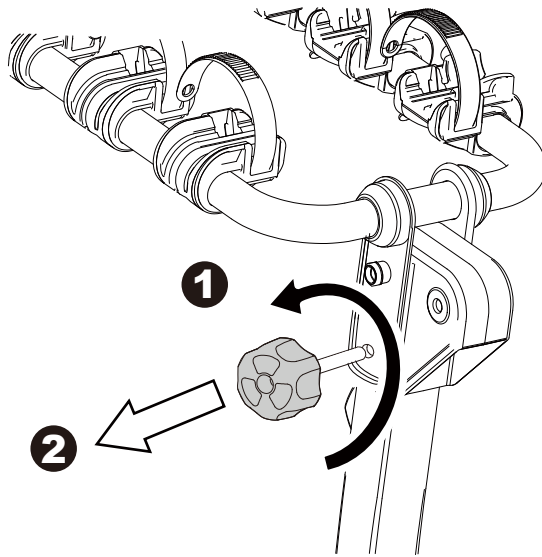

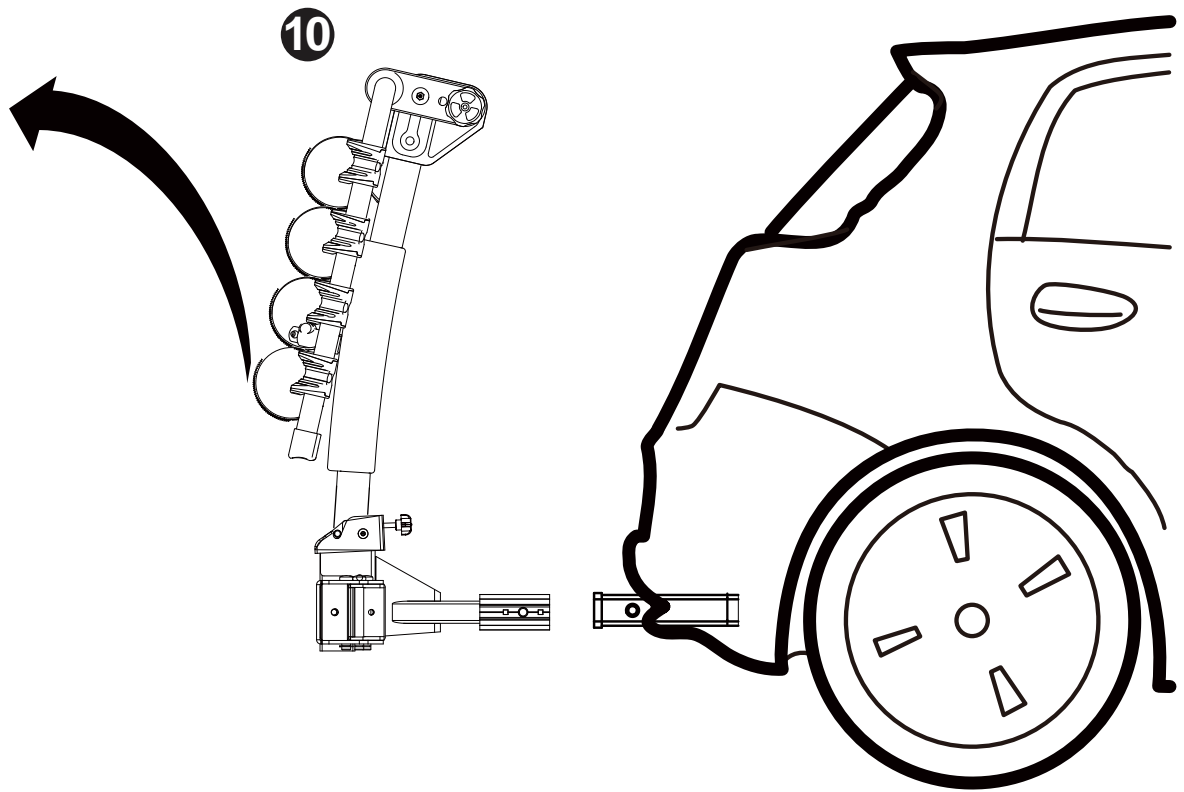
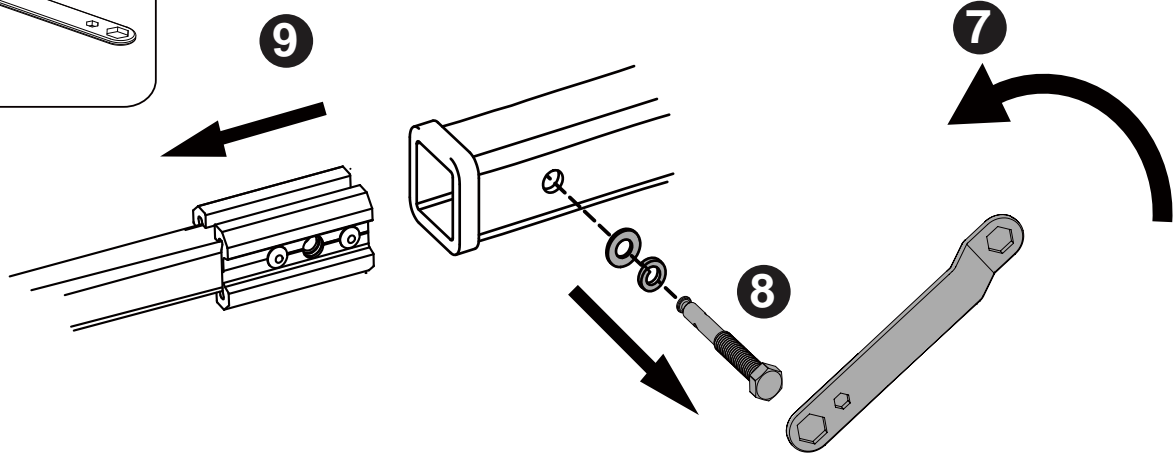
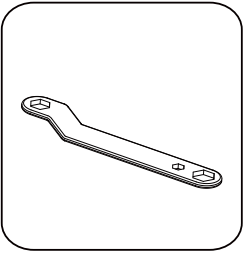

⚠ WARNINGS

EN

GENERAL REMARKS

01. Please read and observe the instructions carefully before you use the product, and keep them in a safe place for future use. Check the part list after opening the package. Make sure that all the parts are fully assembled according to the instruction before fitting it on your car.
02. The user is responsible for assembly and installation of this product, and the manufacturer disclaims any liability due to improper fitting or use of the product.
03. Failure to properly install this bike carrier and/or the bikes may cause damage to the vehicle and/or the bikes, and may result in personal injury.
04. Do not use this product for purposes other than those for which it is designed. Do not modify any components of the product. Remove the carrier if not in use.
05. Do not use the carrier to carry more bikes than recommended. The weight of each bike cannot exceed 15kg/ 33lbs.
06. Do not install the bike carrier on trailers, campers, or RVs.
07. This bike rack is not intended for transporting tandem, or recumbent bicycles.
08. Do not transport bicycles with attached baby seats, panniers, wheel covers, full bike covers or motors.
09. Fits 1 1/4" (3.2 cm) and 2" (5.1 cm) hitch receivers.

SAFE AND PROPER USE

01. Always use the safety strap to attach the bikes to the bike carrier.
02. Check that the hitch tube is properly fastened to the hitch receiver on the car.
03. Check if the distance from the exhaust pipe to the bicycle tires is safe for your bicycles or the straps of the carrier. The heat of the exhaust could damage the bike or bicycle racks.
04. If your vehicle is equipped with an automatic tailgate opening system, disable this function when using the bike carrier, and open the tailgate manually.
05. When loading the bicycles, remove all loose parts and accessories from bicycles (toolbars, baby carriers, pumps, etc.)
06. Always position the biggest/heaviest bike first and closest to the car, and then position the smaller bike after that.
07. The user is responsible for periodically verifying that all hardware, straps, knobs, hubs are securely tightened for safety purposes.
08. You might have to use extra protections to protect the bikes and the tailgate from scratches.
09. Do not open the gate with the bikes installed on the carrier.
10. The locks used on this rack are theft deterrent.

ROAD SAFETY

01. The bicycle rack increases the vehicle's length, and the bicycles may increase its width and height. Be aware of this when passing through narrow or low clearance spaces and when reversing. Any loads exceeding the indicated dimensions must nevertheless respect existing regulations and be properly strapped down.
02. The load of rack and bicycles will affect driving. Do not exceed the speed limit, and do not drive faster than 120 km/h (75 mph).
03. Drive slowly over speed bumps. Respect the speed limit, and adapt your speed to the condition of the road.
04. Off-road driving is not recommended and could result in damage to your vehicle, hitch receiver, bike carrier, or your bikes.
05. If you hit a bump or a hole in the road, stop your vehicle and inspect the bikes and the carrier. If you notice anything wrong, remove the bikes and do not use the bike carrier.
06. Make sure there is a safe distance between the bikes and the ground, especially when entering a driveway.

MAINTAINING YOUR BICYCLE RACK

01. Periodically inspect the product for signs of wear, corrosion, and fatigue.
02. Do not use the carrier with defective parts, contact the dealer to replace them before using it again.
03. Remove the product before entering an automatic car wash.
04. To keep your product in the best condition, it is recommended to remove the product from the car when not in use. Please be advised that this product is not designed to resist extreme weather conditions, especially sea-coast air.
05. Lubricate the bolts in order to avoid corrosion.