



Version 151112

*tilt*AWAY Bike Carrier Assembly Instructions

BEFORE YOU BEGIN

To ensure the best service and satisfaction from your Advantage® SportsRack *tilt*AWAY, please read and follow all instructions, recommendations, and warnings. Heininger Holdings, LLC is not responsible for damage or injury due to misuse of the *tilt*AWAY product. And we always want to hear from you about our products and service.

VERIFY ALL PARTS ARE INCLUDED IN PACKAGE:

- 8 Saddle Straps
- 1 Hex Keys
- 1 Hitch Bolt with lock washer
- 1 Pivot Bolt with 2 washers and 1 nut
- 1 Clevis Pin attached to the foot on the rack with snap pin
- 1 Clevis Pin attached to the arms on the rack with snap pin

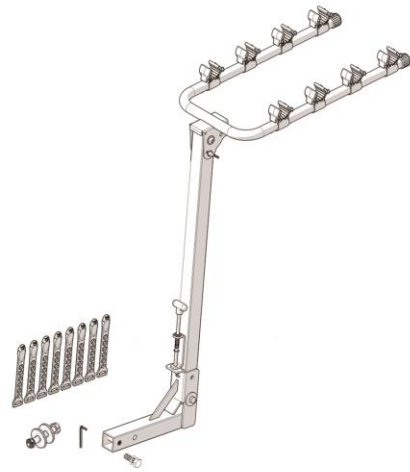

Assembling Your *tilt*AWAY Bike Carrier

To attach the foot (see receiver insert diagram below) to the upright. Slide a washer onto the pivot bolt then slide it through the foot and upright. Put on the second washer on and then secure the nut tightly. Adjust the bike carrier upright to be perpendicular with the foot and insert the Clevis Pin in hole above the lower bolt. Once the Clevis Pin is completely inserted, secure it with the snap pin.

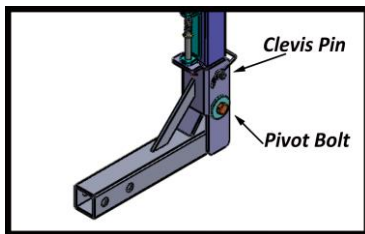

When you raise the arms of the bike rack to a 90 degree angle with the upright and then insert the attached Clevis pin into the hole, secure it with the snap pin. (Not shown)



WARNING! - DO NOT USE ON A TRAVEL TRAILER, 5TH WHEEL, OR TOWED VEHICLE

WARNING! - DO NOT DRIVE OFF-ROAD WITH RACK/BIKES ATTACHED, IT COULD RESULT IN DAMAGE TO VEHICLE, RACK AND BIKES

WARNING! - USE CAUTION WHEN ENTERING STEEP DRIVEWAYS AND GOING OVER SPEED BUMPS

WARNING! - NOT INTENDED or DESIGNED FOR ELECTRIC, MOTORIZED, TANDEM OR RECUMBENT BICYCLES

Connecting Your *tilt*AWAY bike rack to Vehicle

Slide receiver tube of assembled rack into 2" x 2" hitch port of your vehicle.

- Feed the lock washer onto the hitch bolt then the flat washer.
- Insert the hitch bolt into the receiver hole and align with hole in the receiver tube. There are 2 based on the variety of hitches. The rule is to keep the rack as close to the vehicle as is possible. Remember to align the anti-wobble device with the hole you are using in the receiver tube of the rack. The anti-wobble device can be moved from hole to hole by pushing it.
- Once aligned thread the bolt into the receiver tube and tighten with a wrench (preferably a socket and ratchet).
- *****Be sure to tighten the hitch bolt-good and tight)*****
- Adjust the bike arms to the upright position and insert the clevis pin in the open hole where the upright and arms meet. Secure the pin with the included snap pin.
- To tilt the bike carrier away from vehicle, simply remove snap pin and pull the clevis pin from the base of the rack. Lift the T-handle, the upright can now be lowered.



*****Do not operate vehicle when rack & arms are not in a secured position*****

The bike arms should be lowered when not in use. Simply remove the clevis pin from the upright, lower the arms so they are parallel with the upright and re-insert the clevis pin, securing it with the snap pin.

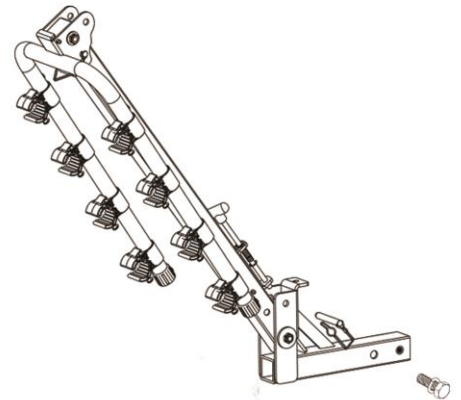



Placing Bicycles on Your *tilt*AWAY Bike Carrier

Place bicycle(s) in saddles of bicycle-carrying arms and secure with included straps. **Always load the heaviest bike first and start closest to the vehicle.** The top tube of your bicycle should ride level between the corresponding saddles of each bicycle-carrying arm. If your particular bicycle frame does not ride level, the saddle can be rotated to accommodate another part of your frame. **A Top Tube adapter** (sold separately) **may be required for women's or kid's bike that have a step through frame. Visit Heininger.biz to learn more about the Top Tube Adapter.**

- Once saddles are in desired location, you can tighten them with included hex key. Each saddle has 2 tightening screws.

Replacements are available by calling Heininger Holdings:

Item/Product	Description
#1012 Saddle Straps	Pack of 4 each
#6039 Anti Wobble Kit (for 2 x 2 receiver tube only)	Nut, bolt, washer and anti-wobble block
#6000 Hitch Extension	Extends 8-11"
#6001 Hitch Lock	Anti-wobble lock rack/vehicle
#6003 Cable Lock	10' Cable Lock
#6009 Top-Tube Adaptor	For women/kids bikes
#1043 Phone Mount	Handlebar holder for cell phone

Rules of the Road on the Use of Your Advantage *tilt*AWAY:

Be safe; take time before travel to make sure the rack and cargo are securely fastened and in proper order.

- Before you drive, with your rack in place, make sure every bolt and nut are tight and securely in place.
- Never use the rack on a towed vehicle
- Do not use this product for anything other than for that which it was designed or to carry more than the specified amount.
- This product is not to be used as a stepladder or elevator in anyway.
- Remove the rack before entering a car wash.
- Do not operate vehicle when rack is not in a secure position.
- Always check travel-lock to insure it is secure before and during your travels.
- Check to see that bikes are securely fastened and insure there is nothing dragging behind the vehicle. Use of an additional strap or bungee cord is a good idea.
- Use of loaded rack on rough road surfaces could result in bike damage.



Care and Maintenance

- As an extra precaution, we recommend you double check the hitch bolt and all *tiltAWAY* fasteners once a month (and every time you reinstall it, whichever is more often) to ensure everything is securely fastened and attached correctly. Address anything that has loosened or shifted over time with vehicle/road vibration.
- When not in use but on the vehicle, lower arms and remove straps to avoid decay from ultraviolet rays.
- For proper operating performance, we recommend you clean your *tiltAWAY* from time to time with soap and water, to ensure salt, sand, grit and other debris do not interfere with *tiltAWAY*'s smooth operation. In winterized-salty conditions, wash the *tiltAWAY* thoroughly at least every week.
- Please remember to remove your *tiltAWAY* if you drive through an automated car wash.
- Routine lubrication of *tiltAWAY* is required around the T-handle shaft to ensure the knob lifts easily and the platform rotates with ease. Use 3-In-One® Oil generously and often.



Please share & show your use of the *tiltAWAY* by uploading photo/comments onto the **Advantage** Facebook page.

Warning!

Do not exceed load rating for the hitch-mounting bracket specified by its manufacturer. Consult hitch-mounting manufacture for load limit if not shown on mount or in the vehicle literature. If load limit is unknown, limit rack capacity to 2 bikes. This carrier has been designed to attach securely to a primary vehicle. It is not compatible with travel trailer, fifth wheel or RV applications. Your attachment is critical and beyond control of the manufacturer. The user of this carrier must secure it properly to the vehicle and you need to regularly inspect parts for tightness, wear and/or damage. The Manufacturer is not responsible for and does not guarantee the attachment of this carrier to any vehicle, and is not liable for any damages resulting from its attachment. **The liability of Heinger Holdings, LLC, is limited to the purchase price of the carrier components which prove defective in materials and/or workmanship.** Be aware that some countries/states/provinces require an unobstructed view of the vehicle license plate. If rack or its cargo obstructs the plate, you may need to relocate your license plate. Consult your local vehicle code for restrictions and rules.

Check out the collection of bike racks we offer.