



PART # 99600 & 99606 - DUAL OUTLET
PART # 99610 & 99616 - SINGLE OUTLET
INSTRUCTION SHEET
AMC JEEP CJ-5, CJ-6, CJ-7 (232 - 258)

CAUTION: This is a custom designed [exhaust header system](#), designed for this particular application (s). Do not bend, bang, cut, dent, drill or heat any portion of this header! Any alteration other than those suggested in this instruction sheet will void the Hedman Lifetime Guarantee!
 To prevent leaks, install your headers using Hedman Hedders exhaust gaskets ONLY and a spray copper gasket sealant.

BEFORE STARTING INSTALLATION:

It is necessary to raise the vehicle at least 36 inches from the ground. A floor hoist is recommended, if not available, use a hydraulic floor jack with jack stands. DO NOT USE A BUMPER JACK!

INSTALLATION INSTRUCTIONS:

NOTE: Disconnect battery and remove spark plugs (Number wires).

1. Disconnect the exhaust head pipe and remove from the work area. Remove air cleaner assembly.
2. Drain radiator.
3. Disconnect throttle cable, automatic choke line, heat riser tube, fuel line and vacuum lines. **(MARK ALL LINES AND FITTINGS TO ENSURE PROPER RE-ATTACHMENT!)**
4. Disconnect power steering pump and its bracket from block. Move them aside.
5. Remove the intake and exhaust manifolds and separate.
6. Surround the intake and water ports with a high temperature silicone sealant.
7. Place the header gasket on studs. Starting from above, work your Hedman Hedder down through the chassis and into position over exhaust ports #3, 4 and 5. Start but **DO NOT TIGHTEN** the stock bolts.

NOTE: # 8 is for two Piece header Part#'s 99600 and 99606 Only!

8. Starting from above, work second part of header down through the chassis (it may be necessary to remove motor mount during this operation) into position over exhaust ports #1, 2 and 6 (Replace motor mount if removed). Start but **DO NOT TIGHTEN**, stock nuts (with washers) on end studs.
9. Work the intake manifold down into position. Be sure not to disturb the silicone seal and check that the manifold aligns properly with the head and header flange. Start the stock nuts and washers on the end studs. Use the two 3/8" x 1 1/2" bolts supplied with your new Hedman Hedder in the remaining two holes on the header flange. Tighten the nuts and bolts evenly. The two end studs are not threaded all the way, so it may be necessary to use flat washers as spacers to tighten the nuts properly.
10. Start the stock bolts using the 8 spacers furnished with your new header, and the stock washers. Do not tighten at this time.
11. Check the alignment between the flange sections. The top of the flange section must be in a straight line.
12. On some models, if the intake hits ports #3 and #4, it will be necessary to file casting flash from the intake manifold. **(1972-86 manifolds only, see illustration).**
13. Tighten ALL header and intake manifold bolts and nuts evenly.
14. Re-install the power steering pump. Reconnect all carburetor lines and linkage. Reinstall air cleaner assembly, refill radiator to proper fluid level and reconnect the battery. Make sure all lines, cables and wires have sufficient clearance.
15. Install reducers and fabricate your remaining stock lead pipe to connect to your new Hedman Hedder.
16. Start your engine, and test drive your vehicle until engine reaches normal operating temperature. Listen for new and unusual noises. After your test drive, re-tighten all bolts and header fasteners.

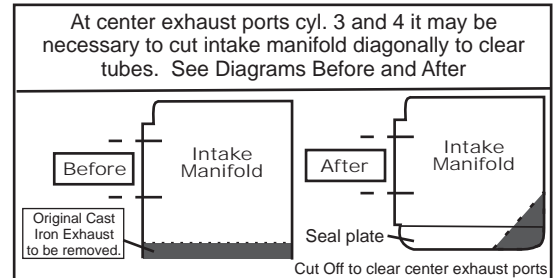

ENJOY YOUR HEADERS WHILE COMBINING INCREASED FUEL ECONOMY WITH BETTER PERFORMANCE.

SPECIAL INSTRUCTIONS!

After installing your headers, it is very important that your exhaust system be suspended properly. As indicated in the drawing below, you must place hangers as close to the header collector as possible. Rubber hangers should be used to allow the front of the system to flex with the engine torque. A hanger is needed before and after the muffler (s). When your exhaust system is unbolted from the header collector, it should remain suspended all by itself. Your headers Are Not designed to support your exhaust system. Failure to follow these instructions will most likely result in cracks around the area where your primary tubes and collector are welded together, and will nullify your "Lifetime Guarantee".

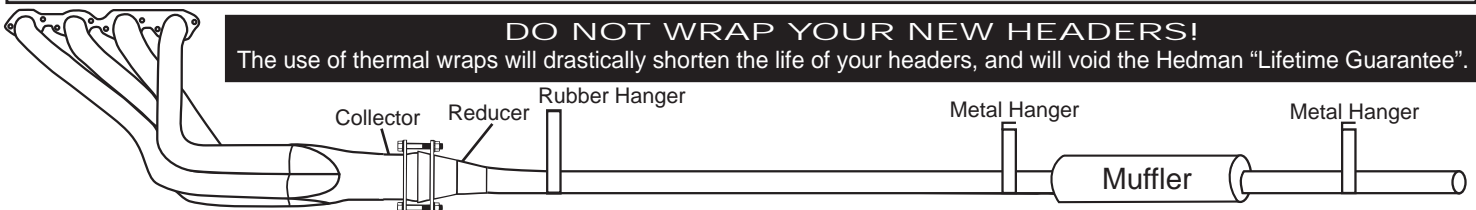

WARNING: Not applicable or intended for street or highway use. Legal only for racing vehicles which may never be used upon a public highway.



HOW TO USE SPACER WITH BOLT OR STUD FOR #99600, 99606, 99610 & 99616

IF USING STUD ASSEMBLE THIS WAY

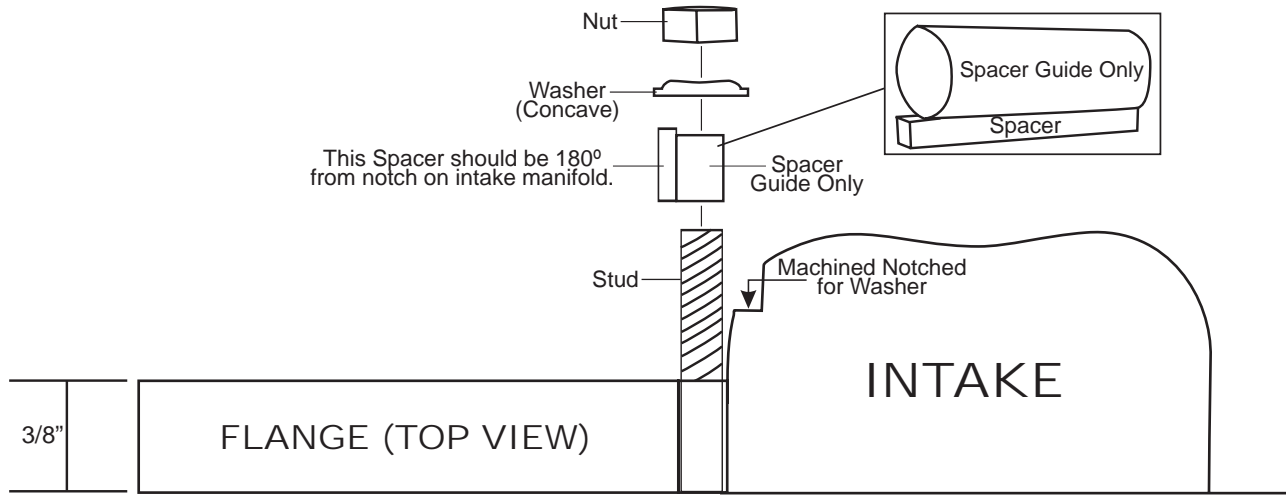

IF USING BOLT ASSEMBLE THIS WAY

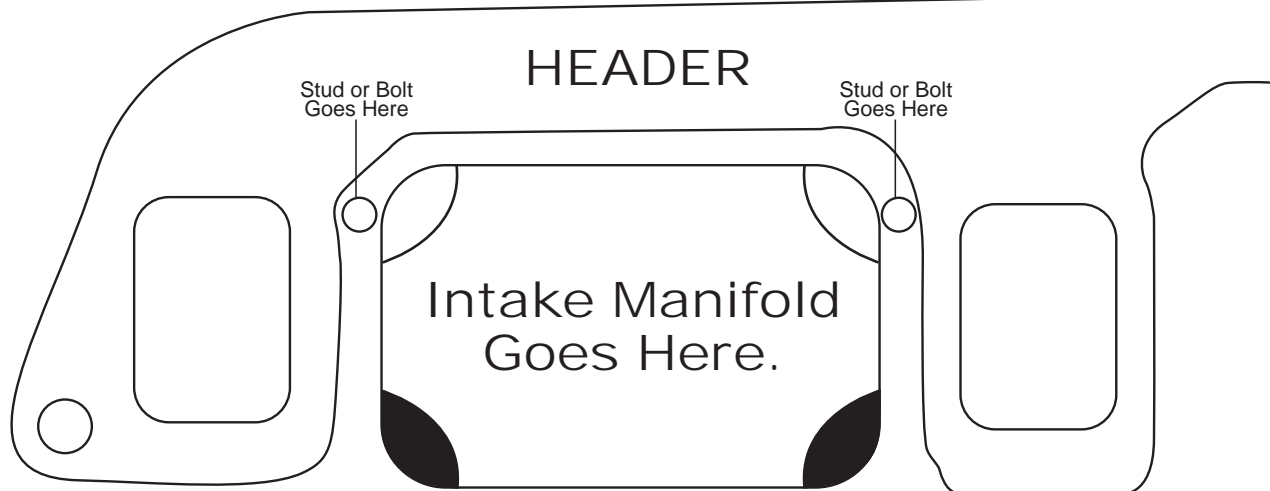
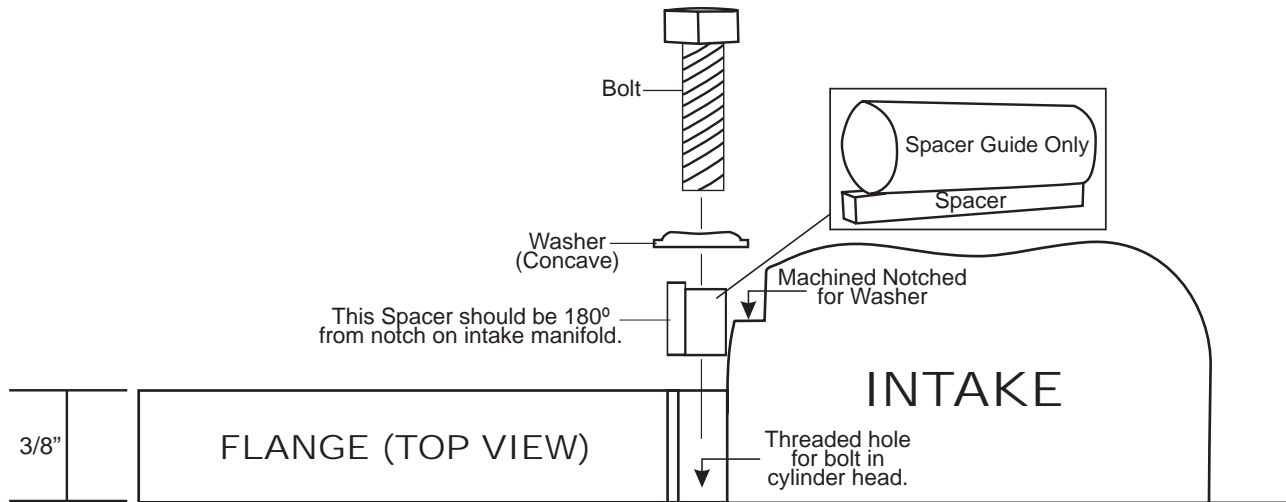

If spacer is too long it may need to be cut to adjust difference in height between intake manifold and header head flange. (If minimal amount of spacer remains, may need to use mill washer, cut 1/3 washer away to use as spacer.)