

HP UNIVERSAL TURBO KIT



Product Installation Sheet

Required Equipment

- Heavy duty scissors or utility knife
- Dust Mask
- Safety Glasses
- Gloves
- Long Sleeves (optional)
- Diagonal pliers
- Needle nose pliers
- Poster board or cardboard for template



GLOVES REQUIRED



SAFETY GLASSES REQUIRED



DUST MASK REQUIRED

Installation Tips

Before getting started it is important to remember to take the proper precautionary measures. Whenever working with high temperature materials it is important to wear safety goggles, a dust mask, and gloves. Be sure to take accurate measurements, a loose fitting turbo blanket will cause premature failure of kit and void the warranty. And as always, it is recommended that you disconnect your negative battery cable before working on your vehicle.

This kit is designed to retain heat in the hot side of the turbo charger (the turbine) on your vehicle. Retaining heat in the hot side of the turbo will allow the exhaust gases to escape the system faster allowing greater exhaust gas air flow and colder air intake temperatures; this increases horsepower. Keeping more heat in the hot side of the turbo will also help keep the turbo "spooled up" which reduces turbo lag and improves throttle response.

For kit number 300002, please wear necessary safety equipment and skip to step number 9.

****Make sure all measurements are accurate, a loose fitting turbo blanket will cause premature failure of turbo kit and void warranty****

Installation Steps

KIT CONTENTS:

- HP Turbo Blanket (Aluminized cloth stitched, 3 layers material; 9" x 19" Kit number 300000 and 300001 only)
- Heatshield Armor™; 10" x 36"; Kit number 300000 and kit number 3000002 only)
- 2 Thermal-Ties™ 33" long (Kit number 300000 and 300001 only)
- 3 Thermal-Ties™ 14" long (Kit number 300000 and 300002 only)

- 1 Be sure to make all measurements as close as possible. A loose fitting turbo blanket may cause premature failure of the kit! Measure around the outside of the exhaust side of the turbo (the hot side) as shown in Figure 2, add 1/4-inch to this measurement, this measurement will be called AB. Use the box located in the lower right hand of drawing on your left to record your measurements.
- 2 Measure around the wide part of the turbo where it meets the flange as seen in Figure 3. Add 1/4-inch to this measurement, this measurement will be called CD.
- 3 Measure around the narrow side of the turbo as seen in Figure 4, add 1/4-inch to this measurement, this measurement will be called EF.
- 4 Using your measurements draw a pattern onto to the 9" x 19" 3 layer piece of material that has aluminized cloth stitched as seen in Figure 5. Cut out your turbo wrap with utility knife or heavy duty pair of scissors.

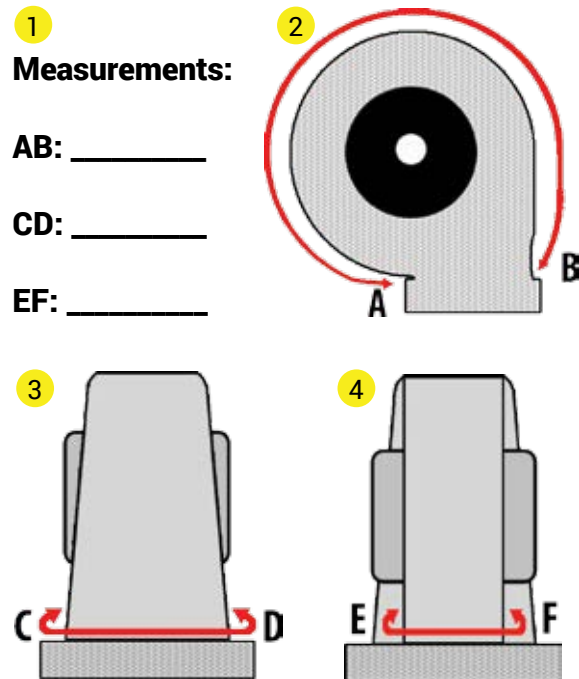

HP UNIVERSAL TURBO KIT

Product Installation Sheet



Installation Steps

- Next you will place a series of marks about a 1/4-inch from the edge of the cut piece of material, Figure 6. Each mark should be between 1/4-inch and 1/2-inch apart and about 1/4-inch long
- Using a utility knife cut holes through both pieces of material at the marks you made in step 5
- Use the (2) 33" long Thermal-Tie™ and thread it through the turbo blanket from steps 4,5, & 6 as seen in Figure 7.
- Lay the material around the turbo. Start on the side closest to the induction compressor and bunch the blanket around the turbo, fasten the Thermal-Tie™. Use the same process on the other side. When both sides have been bunched, tighten up the ties on last time. When trimming the ties be sure to smooth any sharp edges, doing so will help to prevent damage to the blanket. NOTE: If your turbo uses a wastegate actuating lever it may be necessary to cut a hole through the blanket for the lever to protrude. If you have kit number 300001 you are done, if you have kit number 300000 go to step 9.
- Part number 300000 and 300002 only* - Wrap your down pipe using the Heatshield Armor 10" x 36" piece of material. It is important to not completely wrap the down pipe. We recommend leaving a 1 to 2-inch gap between material to allow the down/up pipe to breathe properly as shown in Figure 8. Attach to pipe using the (3)14" Thermal-Ties™.

5

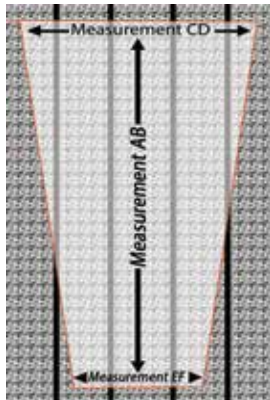

6

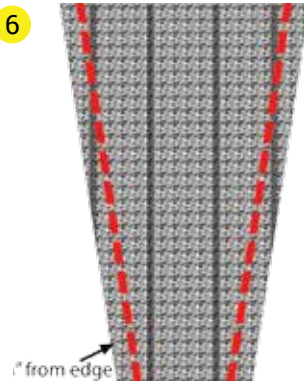

7

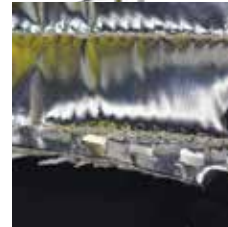
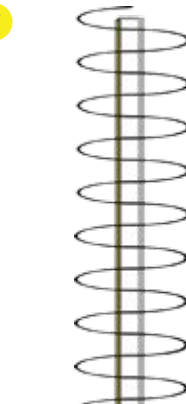

8

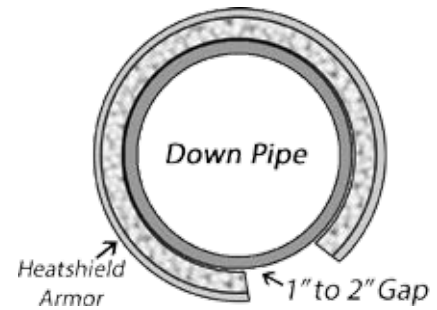

You may also be interested in

HEADER ARMOR™

- Perfect for turbo manifolds
- Reduces radiant heat up to 70%
- Lowers underhood temps by up to 60%
- Water- and chemical-resistant
- 0.003-inch-thick armor layer
- Includes HP Tie Wire™ for installation

