

Havis Heavy Duty Passenger Side Mounts

General Installation Instructions

Required tools to complete installation.

- Large Metric Socket Set (1/2" drive)
- Small Metric and US Standard Socket Set (1/4" drive)
- 7/8" Wrench
- 1/2" Wrench
- 7/16" Wrench
- US Standard Allen Wrench Set
- Phillips head Screwdriver



Complete assembly in vehicle (2010 Ford Focus)

Required parts to complete assembly

Docking Station

(UT-X shown)

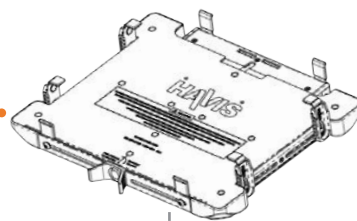

A

Motion Device

C-MD-202

Top Offset Platform

C-HDM-300 Series (C-HDM-303 shown)

Adaptor Plate

C-HDM-301 (included with Top Offset Platform)

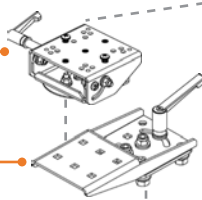

OR

B

Slide Out Locking Swing Arm with Motion Adapter

C-MD-112

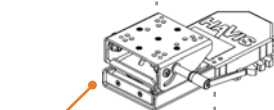

Pole Mount

C-HDM-200 Series (C-HDM-202 shown)

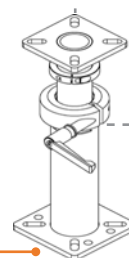

HDM Base & Offset Bracket

C-HDM-100 Series (C-HDM-118 shown)

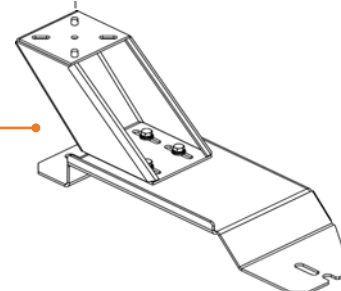

Optional parts for assembly



ChargeGuard®

CG-X



Power Supply

LPS-100/200 Series

Support Arm

C-HDM-401



For installation of Havis products, ALWAYS...

- Read all instructions before installing any Havis, Inc. Products.
- Check for obstructions (wire, brake lines, fuel tank, etc.)
- Use hardware provided with install kit

Havis Heavy Duty Passenger Side Mounts

General Installation Instructions

2010 Ford Focus used for instructions

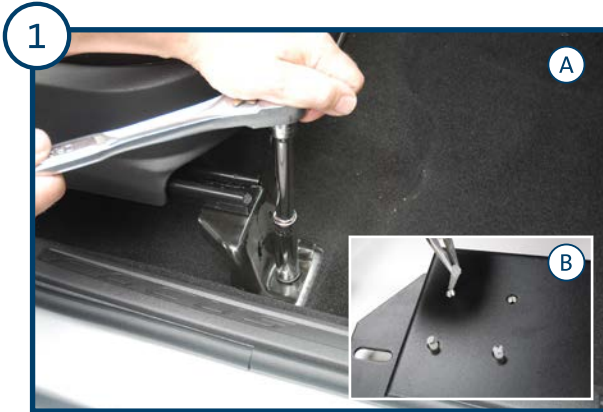

A) Remove the plastic caps that cover the seat bolts. Remove the OEM seat bolts, seat nuts and seat studs, making sure to keep the seat bolts for HDM Base installation (Step 3).
B) Remove all rubber thread protectors from the mounting holes on the HDM Base.



Lift the seat to place the HDM Base between the seat brackets and the floor.
NOTE: Loosening rear seat bolts may be required for ease of installation.



Align the HDM Base mounting holes to seat bolt locations and loosely attach the seat bolts. Use caution to avoid stripping the threads. Fully tighten the bolts once HDM Base is properly in place.

NOTE: Some HDM Bases mount under the vehicle seat bracket and reuse OEM seat bolts (A), while other HDM Bases mount over the top of vehicle seat bracket and use provided spacers and bolts (B).

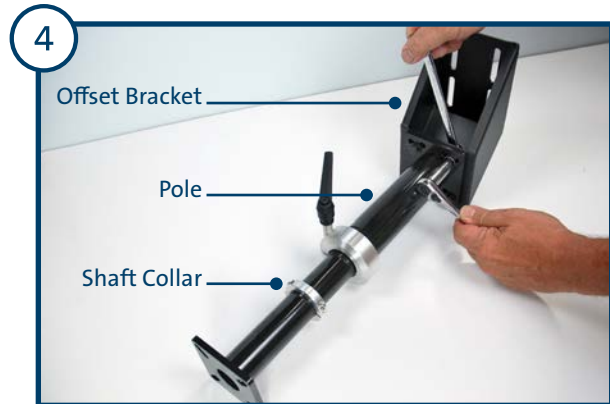

On the workbench, assemble the Offset Bracket and Pole using supplied 5/16" x 1" hex bolts, lock washers, and nuts (x4). Make sure all hardware is fully tightened. Attach the shaft collar anywhere on the inner pole, making sure to leave the shaft collar loose in order to adjust Pole height once installed in vehicle (Step 12).



Attach the assembled Offset Bracket and Pole to the HDM Base inside the vehicle, using supplied 5/16" x 3/4" hex bolts, lock washers, and flat washers. Make sure to adjust Offset Bracket to desired position before all hardware is fully tightened.

NOTE: If your application needs to be closer to center of vehicle, see optional C-HMD-409 Offset Plate.



A) Align the Adaptor Plate mounting studs to the top of the inner pole, then attach using the supplied 5/16" lock washers, flat washers, and nuts. Place the large plastic washer on top of Adaptor Plate.

B) Align Swing Arm with Motion Device mounting holes to the top of the inner pole, then attach using 1/4" lock washers, flat washers, and bolts.

NOTE: Make sure all hardware is fully tightened.

Havis Heavy Duty Passenger Side Mounts

General Installation Instructions

2010 Ford Focus used for instructions

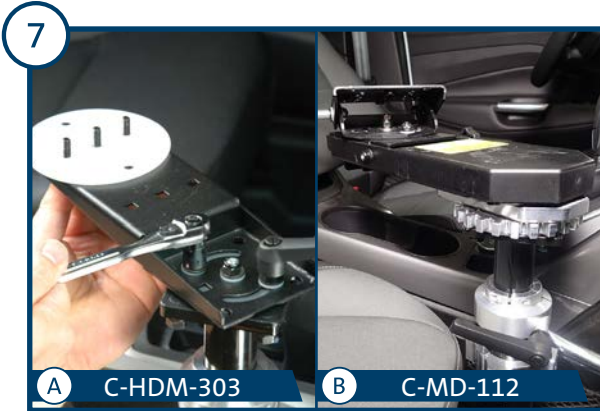

- A) Install the Top Offset with the supplied hardware and handle. Tighten the hardware to allow minimal motion. Place the large plastic washer on the Top Offset.
B) No adjustment required, please proceed to Step 8.

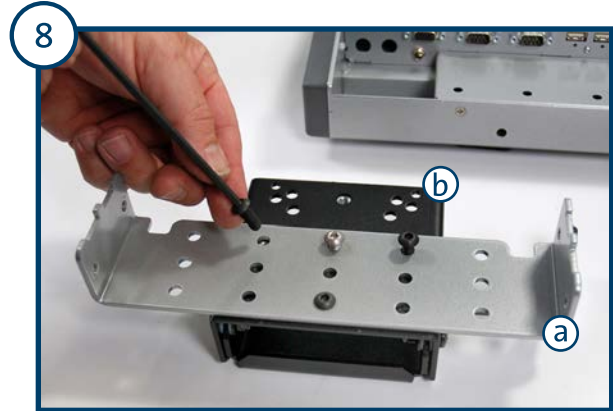

- Remove mounting bracket (a) from the bottom of the Docking Station and attach to the Motion Device (b).
NOTE: If attaching a Universal Laptop Mount (UT-X Series or C-3090 Series), mount directly to the Motion Device.

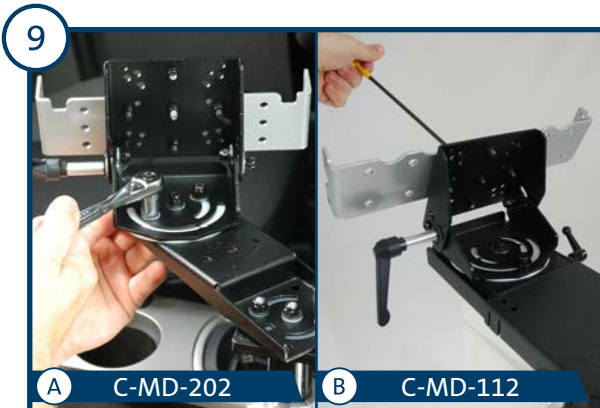

- A) Connect the Motion Device assembly to the Top Offset. Tighten the hardware to allow minimal motion.
NOTE: Motion Device has two (2) sets of holes.
3-bolt pattern allows for 90 rotation.
2-bolt pattern allows for 180 rotation.
B) Motion Device is already connected, please proceed to step 10.



- Attach the Power Supply to the designated mounting location on the Docking Station.



- Attach the Docking Station to the mounting bracket.

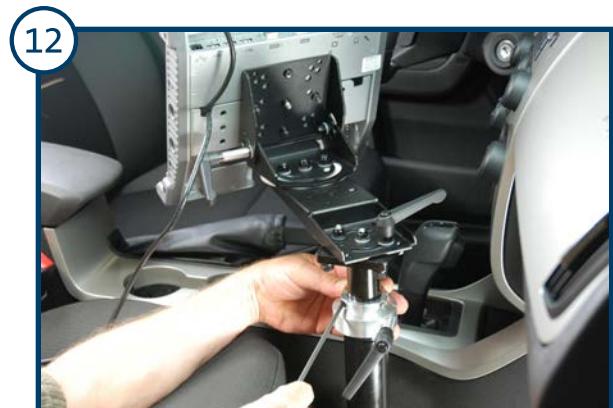

- Adjust the shaft collar to desired height and fully tighten.

Havis Heavy Duty Passenger Side Mounts

General Installation Instructions

2010 Ford Focus used for instructions

13



To attach the optional two-piece support collar to the Pole, attach the side support arm to the two-piece support collar. Attach the side support arm to the underside of the dash with the supplied L bracket. Make sure all hardware is fully tightened.

14



If you are installing the optional ChargeGuard® Power Management System, run power wires to the ChargeGuard and connect to the fused, 12 volt battery. (Additional instructions inside the ChargeGuard box.)

15

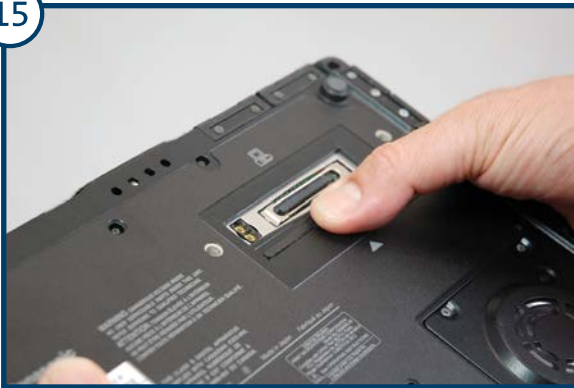

Congratulations, the installation is complete. To properly dock your computer into the Havis Docking Station, you must first open the docking connector door on the bottom of your computer or damages may occur.

16

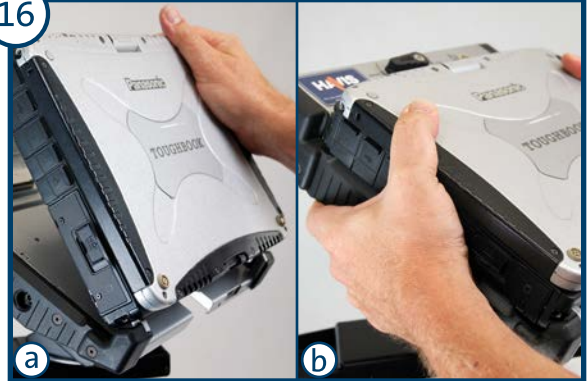

a) Load the front of the computer into the front hooks of the Docking Station.
b) Gently lower the back of the laptop down into the docking connector.

17

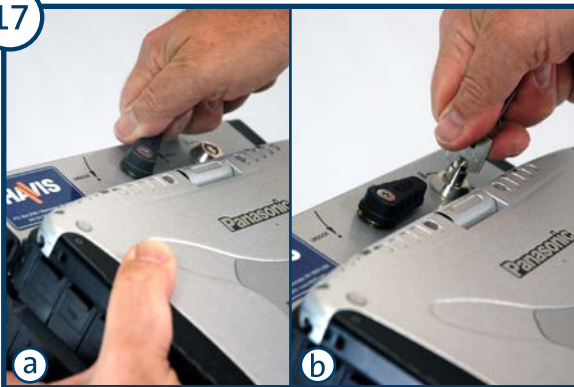

a) With the computer seated, turn the docking latch to the DOCK position.
b) Secure by locking the barrel lock with the supplied key.

18



You have successfully and safely docked your computer.

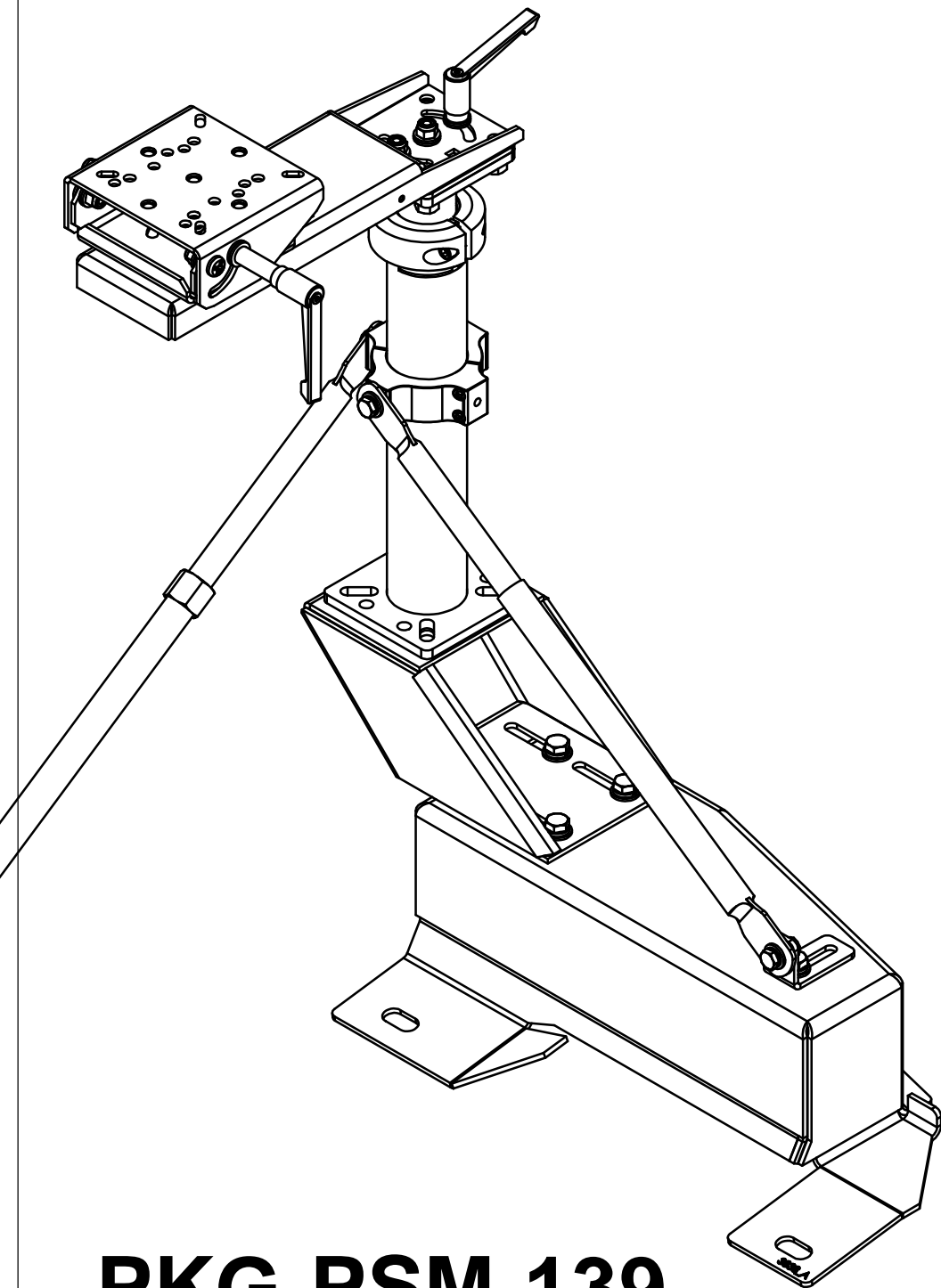

PKG-PSM-139

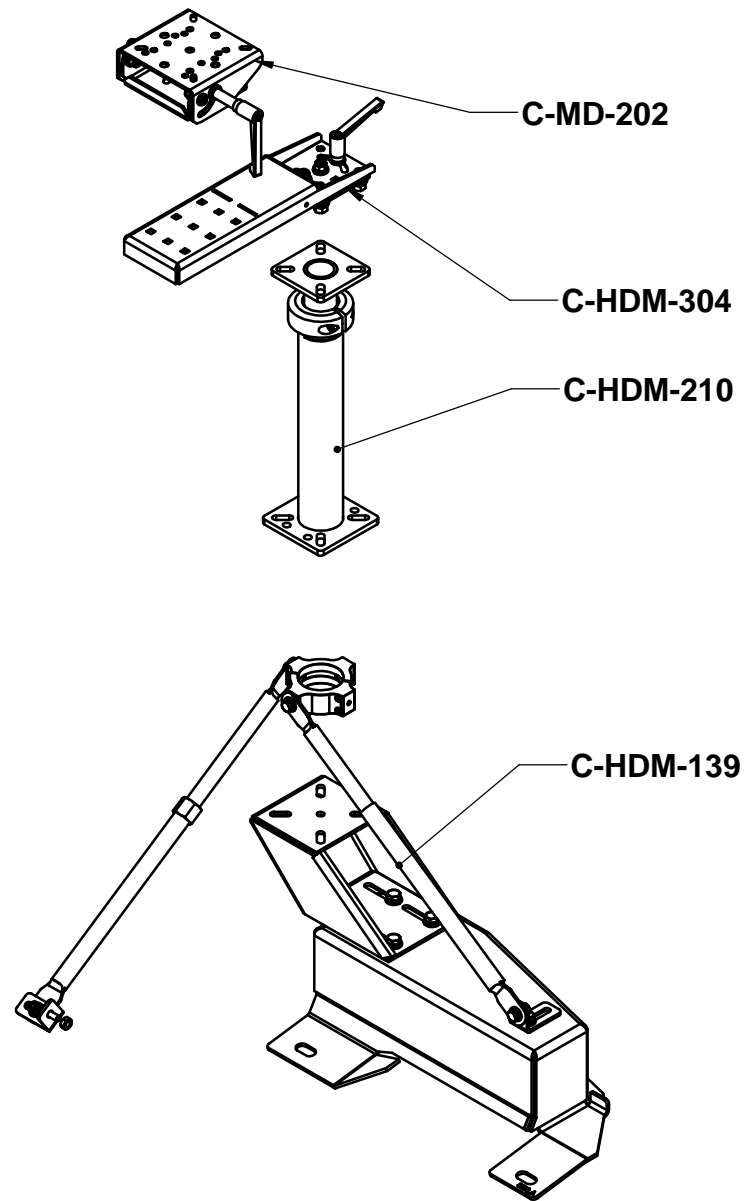

PROJECT #	REV.	DESCRIPTION	DATE	BY	CHECKED BY
1765	3-13	REVISION DATE CORRECTED TO PT895 DOCUMENTED CHANGE. NO OTHER CHANGES	8/5/2014	KDAVIS	

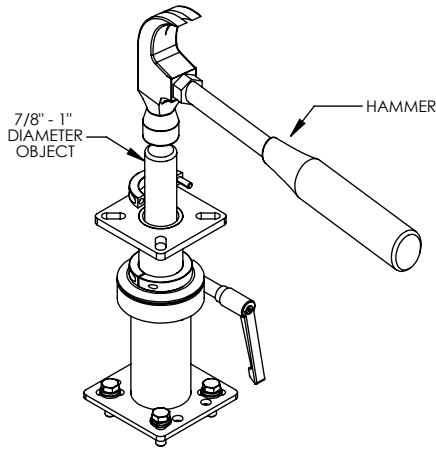

A-GUIDE RING BUSHING REMOVAL
WE STRONGLY RECOMMEND NOT TO REMOVE THE GUIDE RING BUSHING, BUT IF REMOVAL OF INNER POLE IS DESIRED - FOLLOW THIS SIMPLE REMOVAL INSTRUCTION

1. INSERT MAXIMUM 1" DIAMETER OBJECT WITH SUFFICIENT LENGTH AND DROP INSIDE INNER POLE.
2. MAKE SURE NOTHING PREVENTS GUIDE RING BUSHING FROM BEING EJECTED UNDERNEATH. HIT WITH A HAMMER TO FORCE THE GUIDE RING BUSHING OUT.

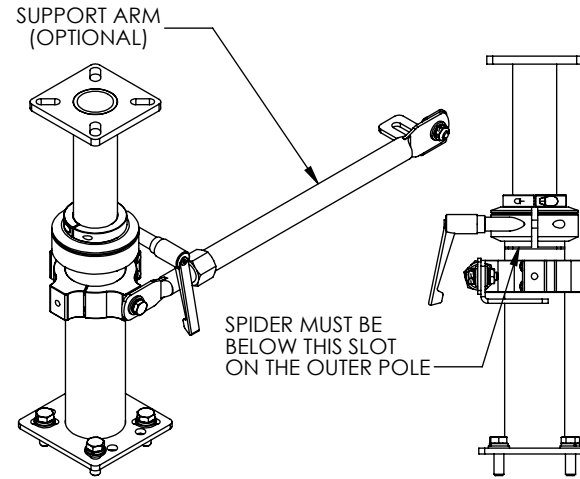

B - INSTALL SPIDER COLLAR (OPTIONAL COMES WITH C-HDM-401 & 403)

1. IF MOUNTING THE SPIDER COLLAR TO THE INNER POLE USE CM003406 REDUCING BUSHING. SPREAD AND SNAP OVER THE INNER POLE.
2. LOOSELY ATTACH SPIDER COLLAR TO THE OUTER POLE OR CM003406. DO NOT MOUNT SPIDER COLLAR ABOVE OUTER POLE HORIZONTAL CUT.

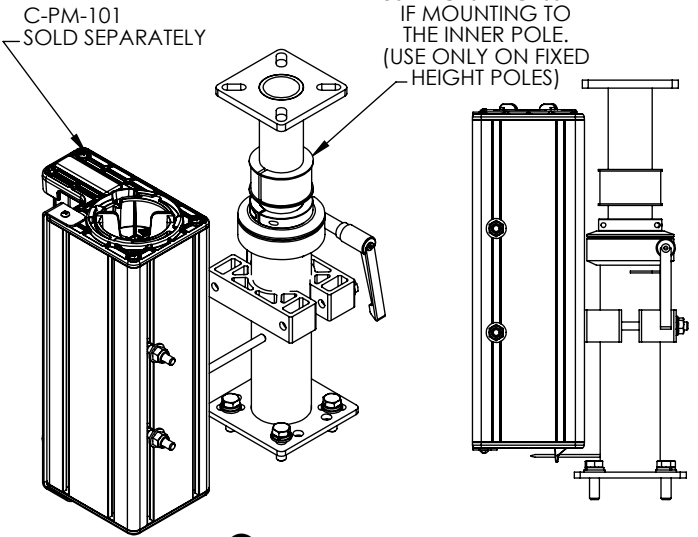

C - INSTALL OPTIONAL C-HDM-416

1. IF MOUNTING C-HDM-416 TO THE INNER POLE USE CM003406. SPREAD THE PIECE AND IT SHOULD SNAP OVER THE INNER POLE.
2. ATTACH C-PM-101 TO CLAMP ASSEMBLY USING LONG CARRIAGE BOLTS INSERTED THROUGH THE PRINTER AND ONE PIECE OF EXTRUSION.
3. ATTACH POLE CLAMP TO THE OUTER POLE OR CM003406. AFFIX SECOND PIECE OF EXTRUSION AROUND POLE AND LOOSELY TIGHTEN THE HARDWARE. DO NOT MOUNT CLAMP ABOVE OUTER POLE HORIZONTAL CUT.

D- INSTALL GAS SHOCK (OPTIONAL)

1. (SKIP IF GAS SHOCK IS NOT IN USE)
2. UNSCREW SMALL PLASTIC DISC FROM SHOCK INSERT GAS SHOCK ASSEMBLY UPWARD FROM THE BOTTOM OF HDM POLE ASSEMBLY WITH GAS SHOCK'S ROD FACING DOWNWARD. GAS SHOCK WILL SANDWICH BETWEEN MOUNTING BASE C-HDM-100 SERIES (NOT SHOWN) AND ACTION ADAPTER C-HDM-300 SERIES (NOT SHOWN).
3. ONCE GAS SHOCK SITS PROUD OF THE INNER POLE REATTACH SMALL PLASTIC DISC

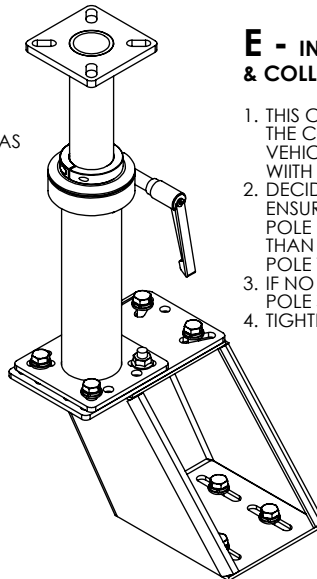
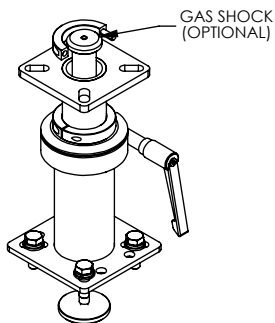

E - INSTALL C-HDM-409 OPTIONAL & COLLAR CLAMP ALIGNMENT

1. THIS CAN BE DONE EITHER AT THIS POINT OR ONCE THE C-HDM-100 SERIES BASE IS ALREADY IN THE VEHICLE. YOU WILL NEED THE OFFSET THAT WAS WITH THE C-HDM-100 BASE IF APPLICABLE.
2. DECIDE ON THE ORIENTATION OF THE C-HDM-409. ENSURING THAT IF THE HANDLE VERSION OF THE POLE IS BEING USED THE TWO SLOTS ARE NO MORE THAN 45 DEG APART IF THIS IS THE CASE ROTATE THE POLE TO THE CORRECT POSITION.
3. IF NO HANDLE IS BEING USED ENSURE THE OUTER POLE SLOT AND THE CLAMP COLLAR SLOT LINE UP.
4. TIGHTEN ALL THE HARDWARE.

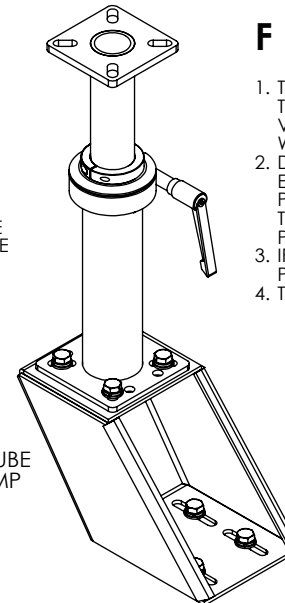
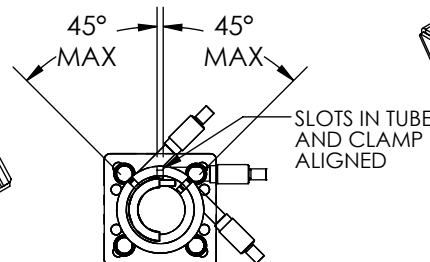

F - INSTALL C-HDM-410-412 OPTIONAL

1. THIS CAN BE DONE EITHER AT THIS POINT OR ONCE THE C-HDM-100 SERIES BASE IS ALREADY IN THE VEHICLE. YOU WILL NEED THE OFFSET THAT WAS WITH THE C-HDM-100 BASE IF APPLICABLE.
2. DECIDE ON THE ORIENTATION OF THE OFFSET. ENSURING THAT IF THE HANDLE VERSION OF THE POLE IS BEING USED THE TWO SLOTS ARE NO MORE THAN 45 DEG APART IF THIS IS THE CASE ROTATE THE POLE TO THE CORRECT POSITION.
3. IF NO HANDLE IS BEING USED ENSURE THE OUTER POLE SLOT AND THE CLAMP COLLAR SLOT LINE UP.
4. TIGHTEN ALL THE HARDWARE.

HAVIS HAVIS, INC.

TITLE:
INSTALLATION INSTRUCTIONS, C-HDM MOUNTING BASES

DO NOT SCALE DRAWING

SIZE A	DWG. NO. C-HDM_INST	REV 3-13
------------------	-------------------------------	--------------------

WEIGHT (LB): 12.634 SCALE: 1:8 SHEET 1 OF 4

FOR VEHICLE MOUNTING THAT REQUIRES DRILLING

1. INSPECT ALL AREAS BEFORE DOING ANY DRILLING ENSURE NO SERIOUS DAMAGE HAPPENS TO THE VEHICLE.
2. SECURE THE MOUNT WITH SUPPLIED HARDWARE KIT.

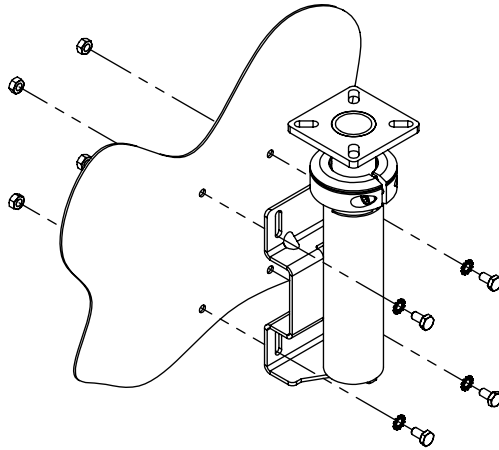

**C-HDM-204 SHOWN
STANDARD FLAT SURFACE
MOUNTING**

FOR FLAT SURFACE MOUNTING OF C-HDM-204, 205, 212, 213, 214, 215, 216 AND 217 (INCLUDING HAVIS CONSOLES WHICH DO NOT HAVE HOLES PRE-DRILLED)

1. POSITION POLE MOUNT IN DESIRED LOCATION
2. MARK AND DRILL 1/4" HOLES INTO THE MOUNTING SURFACE (SEE NOTES FOR DRILLING)
3. THROUGH-BOLT USING 1/4" HARDWARE PROVIDED WITH THE MOUNT OR EQUIVALENT HARDWARE IF NECESSARY.

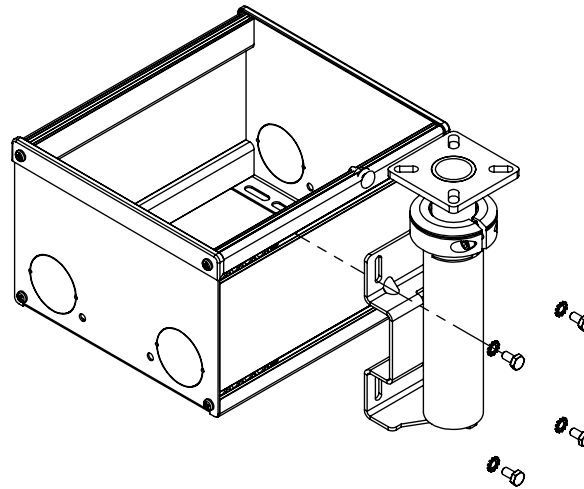

**C-HDM-204 SHOWN
STANDARD CONSOLE SIDE
MOUNTING**

FOR CONSOLE SIDE MOUNTING OF C-HDM-204, 205, 212, 213, 214, 215, 216 AND 217 (WHERE CONSOLE HAS PRE-INSTALLED NUTS IN CONSOLE RAIL)

1. TO ATTACH C-HDM-204, 205, 214, 215
2. LOOSEN THE RETAINING SET SCREW TO ALLOW THE NUTS TO BE POSITIONED AS DESIRED IN THE TRACK.
3. LINE UP THE MOUNT WITH THE NUTS IN THE CONSOLE,
4. ATTACH USING HARDWARE PROVIDED WITH THE MOUNT, OR EQUIVALENT 1/4-20 X 1/2" LONG (MAX.) BOLTS AND FLAT WASHERS.

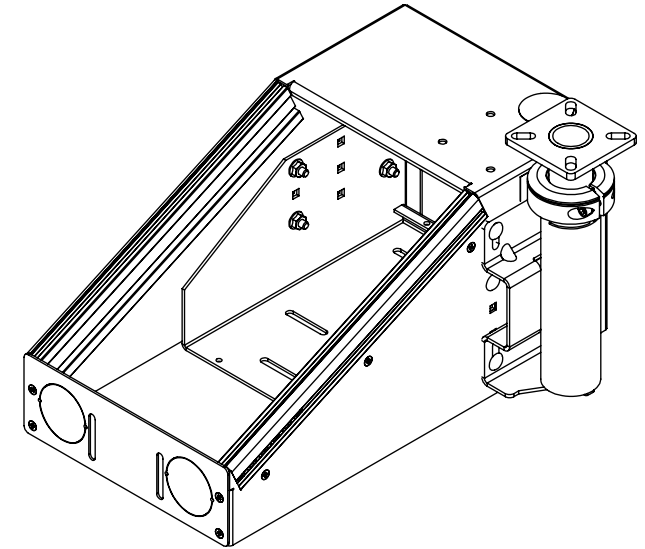

**C-HDM-204 SHOWN
PRE-DRILLED CONSOLE SIDE
MOUNTING**

FOR CONSOLE SIDE MOUNTING OF C-HDM-204, 205, 212, 213, 214, 215, 216 AND 217 (WHERE CONSOLE HAS PRE-INSTALLED NUTS IN CONSOLE RAIL)

1. TO ATTACH C-HDM-204, 205, 214, 215
2. LINE UP THE MOUNT WITH THE PREDRILLED HOLES IN THE CONSOLE,
3. ATTACH USING HARDWARE PROVIDED WITH THE MOUNT, OR EQUIVALENT 1/4-20 BOLTS.
4. DEPENDING ON THE DESIRED POSITION, HOLES MAY NEED TO BE DRILLED, OR ONE (1) BOLT CAN USE THE NUT TRACK WITH A 1/4-20 X 1/2" LONG BOLT.

**NOTE:
MOST C-VS (VEHICLE SPECIFIC)
SERIES CONSOLES HAVE HOLES FOR
AN HDM-204 OR 214 PRE-DRILLED.
IF ANOTHER LOCATION IS DESIRED,
HOLES MAY NEED TO BE DRILLED**

HAVIS HAVIS, INC.

TITLE:
INSTALLATION INSTRUCTIONS, C-
HDM MOUNTING BASES

DO NOT SCALE DRAWING

SIZE A	DWG. NO. C-HDM_INST	REV 3-13
WEIGHT (LB): 0.00	SCALE: 1:8	SHEET 2 OF 4

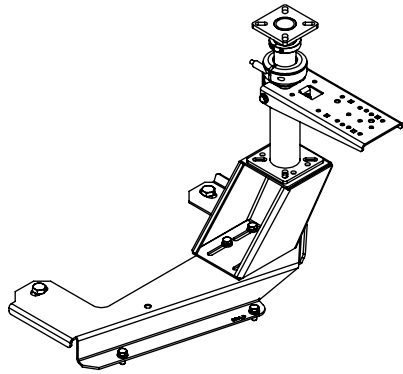

A- C-HDM-403 HORIZONTAL PRINTER MOUNT

1. LOOSELY ATTACH SPIDER (CLAMP) COLLAR TO POLE WITH HARDWARE SUPPLIED (IF NOT ALREADY ATTACHED). POSITION AS DESIRED AND TIGHTEN HARDWARE.
2. ATTACH C-HDM-403 PLATE USING HARDWARE PROVIDED. AVOID TIGHTENING SCREWS IF AN OFFSET ARM IS TO BE ADDED.
3. ATTACH DESIRED ITEM TO SHELF BRACKET.
4. **THE C-HDM-403 WORKS VERY WELL IF THERE IS NO CENTER CONSOLE. SPACE IS VERY LIMITED AND WILL CAUSE LACK OF LEG ROOM IF THE VEHICLE DOES HAVE A CENTER CONSOLE.**

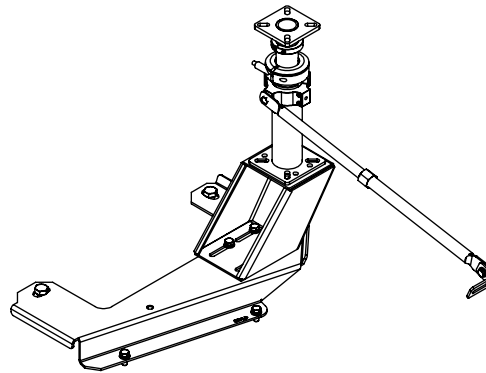

B- C-HDM-401 SUPPORT ARM

1. LOOSELY ATTACH SPIDER (CLAMP) COLLAR TO POLE WITH HARDWARE SUPPLIED (IF NOT ALREADY ATTACHED). POSITION AS DESIRED AND TIGHTEN HARDWARE.
2. LOOSELY ATTACH C-HDM-401 USING HARDWARE PROVIDED.
3. FIND A SUITABLE LOCATION TO ATTACH THE OTHER END OF THE SUPPORT ARM. SOME VEHICLES HAVE HOLES UNDER THE DASH OR OEM HARDWARE THAT CAN BE UTILISED. LOOSELY ATTACH TAB PROVIDED.
4. EXTEND THE ARM ATTACHING THE TAB TO THE SUPPORT ARM WITH THE HARDWARE PROVIDED.
5. TIGHTEN ALL HARDWARE.

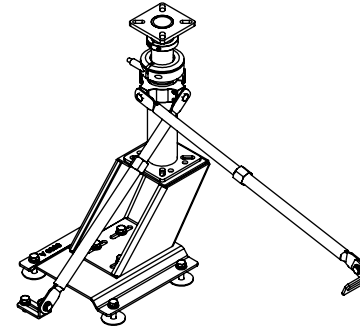

C- C-HDM-404 SUPPORT ARM

1. THE C-HDM-404 IS PRIMARILY USED FOR UNIVERSAL FLOOR MOUNTS WHEN PREMIUM STRENGTH / 3 POINT MOUNTING IS NECESSARY.
2. COMPLETE SECTION B.
3. LOOSELY ATTACH C-HDM-404 USING HARDWARE PROVIDED.
4. THE MAJORITY OF HAVIS BASES HAVE AN EXTRA PEM IN ORDER TO ATTACH TO THE SUPPORT ARM. IF NOT FIND ANOTHER LOCATION OR DRILL AND THROUGH BOLT THE TAB BRACKET.
5. EXTEND THE SUPPORT ARM AND ATTACH WITH SUPPLIED HARDWARE.
6. TIGHTEN ALL HARDWARE.

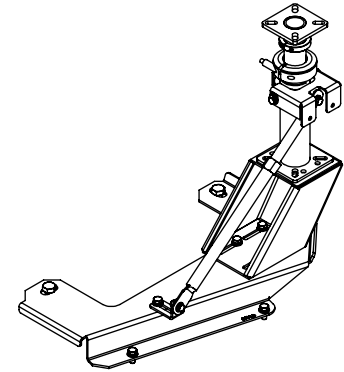

D- C-HDM-417 VERTICAL PRINTER MOUNT

1. COMPLETE SECTION B.
2. LOOSELY ATTACH C-HDM-417 BRACKET USING THE HARDWARE PROVIDED.
3. SLIDE TWO CARRIAGE BOLTS IN THE C-PM-101 SLOTS.
4. LOCATE THE TWO HOLES IN THE C-HDM-417 BRACKET PUSH THE CARRIAGE BOLTS THROUGH THE HOLES AND FINGER TIGHTEN THE SERRATED NUTS PROVIDED.
5. SLIDE THE PRINTER TO THE RIGHT POSITION AND TIGHTEN ALL HARDWARE.

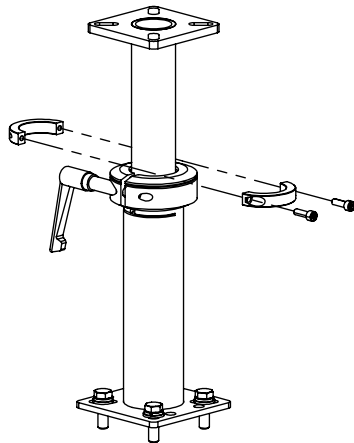

E- ATTACHING THE SHAFT STOP COLLAR THAT COMES WITH TELESCOPING POLE WITH HANDLE

1. SLIDE THE INNER POLE TO THE DESIRED HEIGHT.
2. ATTACH THE SHAFT COLLAR USING THE HARDWARE PROVIDED.
3. INNER POLE SHOULD NOW SPIN FREELY WHILE MAINTAINING THE DESIRED HEIGHT.

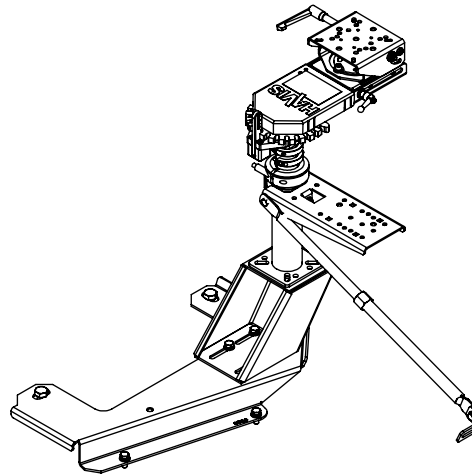

F- EXAMPLE OF A FINISHED ASSEMBLY

1. THE ABOVE ASSEMBLY INCLUDES A C-HDM-102, C-HDM-202, C-MD-102, C-HDM-403, C-HDM-404(2X)

D- C-HDM-417 VERTICAL PRINTER MOUNT SHOWN WITH C-PM-101 ATTACHED

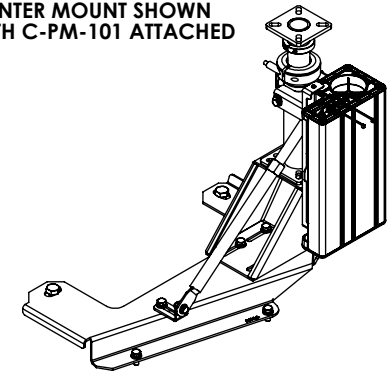

HAVIS HAVIS, INC.

TITLE:
INSTALLATION INSTRUCTIONS, C-
HDM MOUNTING BASES

DO NOT SCALE DRAWING

SIZE A	DWG. NO. C-HDM_INST	REV 3-13
WEIGHT (LB): 19.41	SCALE: 1:8	SHEET 3 OF 4

GENERAL C-HDM-300's INSTALL INSTRUCTIONS

1. ALIGN 4 MOUNTING STUDS OF MOUNTING DEVICE C-HDM-300's INTO THE HDM-200's SERIES MOUNTING SLOTS.
2. BOLT THE MOUNT TOGETHER USING SPECIFIED AND SUPPLIED HARDWARE.
3. TORQUE THE 5/16 HARDWARE TO INDUSTRY STANDARDS .
4. 1/4-20 FEMALE HANDLE CAN BE SUBSTITUTED FOR 1/4-20 NYLOCK NUT.
5. IF THE C-HDM-300 IS TO BE STATIONARY BOLT DIRECTLY TO THE POLE USING 5/16-18 HARDWARE.

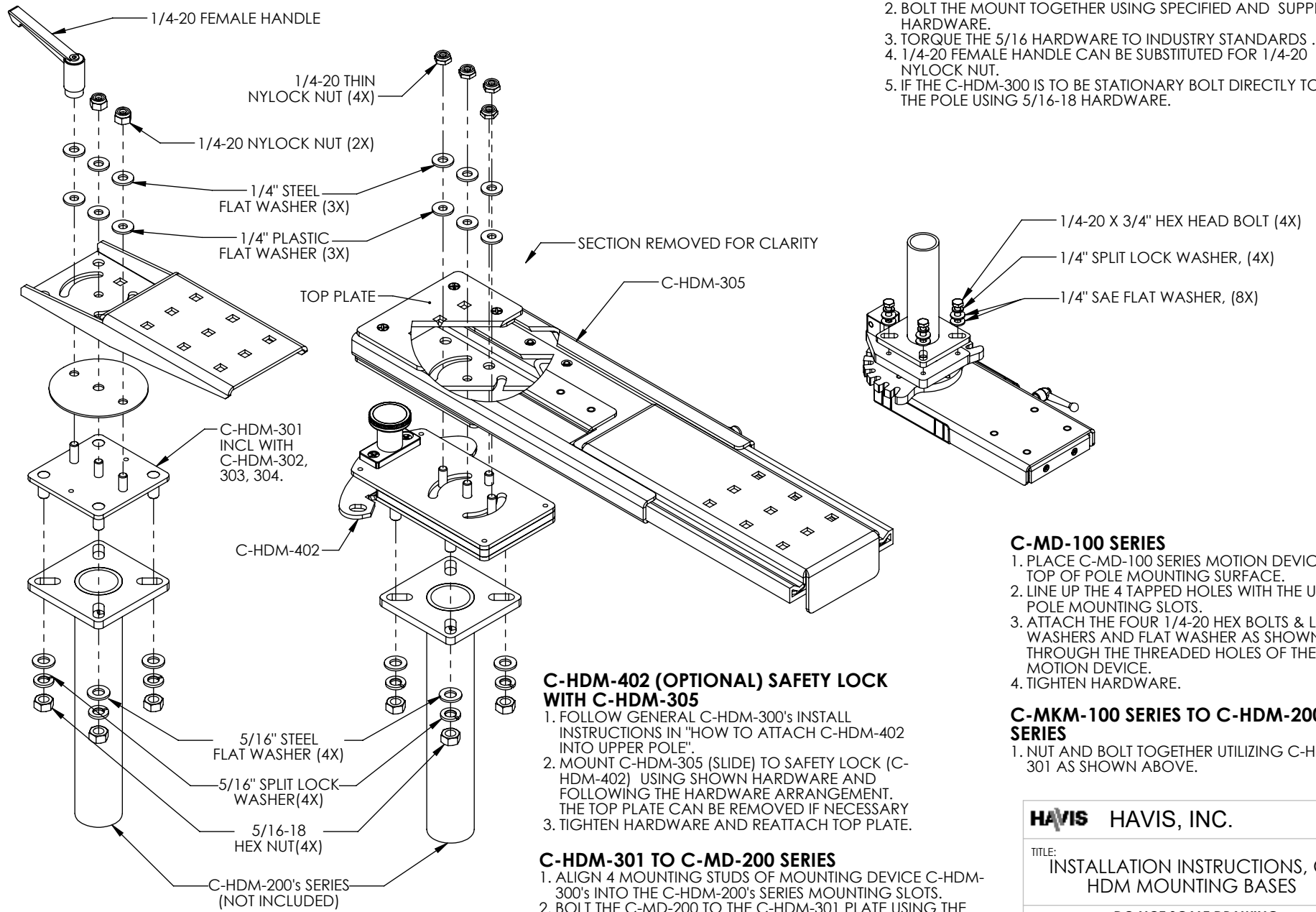

C-HDM-402 (OPTIONAL) SAFETY LOCK WITH C-HDM-305

1. FOLLOW GENERAL C-HDM-300's INSTALL INSTRUCTIONS IN "HOW TO ATTACH C-HDM-402 INTO UPPER POLE".
2. MOUNT C-HDM-305 (SLIDE) TO SAFETY LOCK (C-HDM-402) USING SHOWN HARDWARE AND FOLLOWING THE HARDWARE ARRANGEMENT. THE TOP PLATE CAN BE REMOVED IF NECESSARY.
3. TIGHTEN HARDWARE AND REATTACH TOP PLATE.

C-HDM-301 TO C-MD-200 SERIES

1. ALIGN 4 MOUNTING STUDS OF MOUNTING DEVICE C-HDM-300's INTO THE C-HDM-200's SERIES MOUNTING SLOTS.
2. BOLT THE C-MD-200 TO THE C-HDM-301 PLATE USING THE SAME HARDWARE CONFIGURATION FOR THE C-HDM-300 SERIES.
3. TIGHTEN HARDWARE.

C-MD-100 SERIES

1. PLACE C-MD-100 SERIES MOTION DEVICE ON TOP OF POLE MOUNTING SURFACE.
2. LINE UP THE 4 TAPPED HOLES WITH THE UPPER POLE MOUNTING SLOTS.
3. ATTACH THE FOUR 1/4-20 HEX BOLTS & LOCK WASHERS AND FLAT WASHER AS SHOWN THROUGH THE THREADED HOLES OF THE MOTION DEVICE.
4. TIGHTEN HARDWARE.

C-MKM-100 SERIES TO C-HDM-200 SERIES

1. NUT AND BOLT TOGETHER UTILIZING C-HDM-301 AS SHOWN ABOVE.

HAVIS HAVIS, INC.

TITLE:
INSTALLATION INSTRUCTIONS, C-
HDM MOUNTING BASES

DO NOT SCALE DRAWING

SIZE A	DWG. NO. C-HDM_INST	REV 3-13
WEIGHT (LB): N/A	SCALE: 1:8	SHEET 4 OF 4

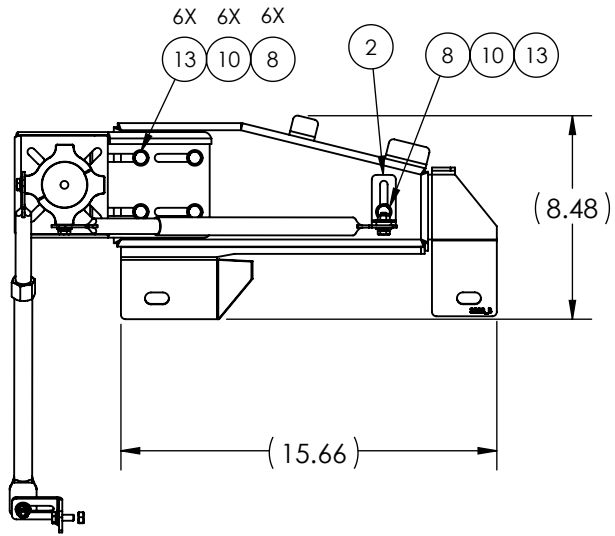

TOP VIEW

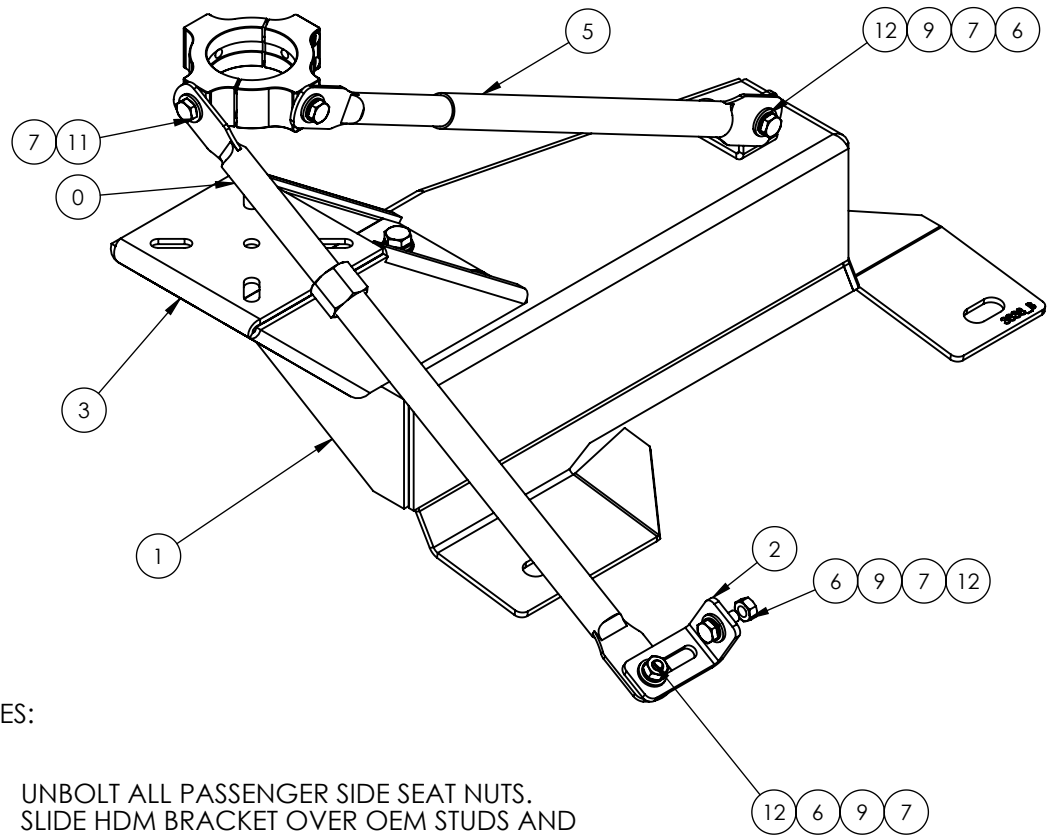

ITEM NO.	QTY.	PART NUMBER	DESCRIPTION
1	1	10-003838	BRKT, HDM CHEVY VAN BASE
2	4	CM002267	BRACKET, LATCH, UNIVERSAL MOUNTING
3	1	CM002400	BRACKET, MOUNT, 45° 3.5" LOWER OFFSET BASE W/SLOTS
4	2	CM002624	EXTRUSION SPIDER, COLLAR HALF
5	2	GSM01260	ASSY SUPPORT ARM 12.5-19"
6	8	GSM30005	NUT 1/4-20 HEX BLK, ZINC, GRD 5
7	10	GSM31005	WASHER, 1/4 FLAT ZP, BLACK
8	6	GSM31006	WASHER, 5/16" FLAT, SAE ZP
9	8	GSM31026	WASHER 1/4 LOCK ZP BLK
10	6	GSM31027	WASHER, 5/16" LOCK, ZP
11	2	GSM33000	SCREW 1/4-20 X 1/2 HHCS, BLK, ZP, GRD 5
12	8	GSM33001	SCREW 1/4-20 x 3/4" HHCS ZP BLK
13	6	GSM33011	SCREW, 5/16-18 X 3/4"
14	4	GSM34214	SHCS, STAINLESS 10-24 X 1-1/4" LG

NOTES:

1. UNBOLT ALL PASSENGER SIDE SEAT NUTS.
2. SLIDE HDM BRACKET OVER OEM STUDS AND PLACE THE SEAT OVER THE BRACKET.
3. TIGHTEN ALL SEAT NUTS TO VEHICLE MANUFACTURER'S TORQUE SPECIFICATION.
4. ATTACH LOWER OFFSET TO BASEPLATE WITH 5/16" BOLTS, LOCK WASHERS AND FLAT WASHERS (ANGLE TOWARDS CENTER OF VEHICLE.)
5. INSTALL HDM POLE (NOT INCLUDED) ONTO LOWER OFFSET.
6. INSTALL SPIDER ON THE HDM POLE AS A SNUG FIT.
7. FIX SUPPORT ARMS TO THE SPIDER USING HARDWARE FROM C-HK-102 HARDWARE KIT.
8. ATTACH LOWER END OF FORWARD ARM TO THE BASE USING ONE 10-002267 BRACKET AND HARDWARE FROM C-HK-105 HARDWARE KIT.
9. FIX A 10-002267 BRACKET ONTO LOWER END OF INBOARD SUPPORT ARM AND AGAINST THE SEAT BASE. ATTACH TO ARM AND SEAT BASE WITH HARDWARE FROM C-HK-105.
10. TIGHTEN ALL HARDWARE.

HAVIS HAVIS, INC.		
TITLE: 97-18 GM VAN FRONT MOUNT HDM BASE		
DO NOT SCALE DRAWING		
SIZE A	DWG. NO. C-HDM-139-INST	REV 7-16
WEIGHT (LB): 13.63	SCALE: 1:8	SHEET 1 OF 1