

## INSTALLATION INSTRUCTIONS

1. REMOVE PASSENGER SIDE FRONT SEAT BOLT ON TRANSMISSION TUNNEL.
2. LIFT SEAT SO THAT THE SEAT BRACKET IS CLEAR OF THE FLOOR AND SLIP THE BASE BRACKET UNDERNEATH, ROTATING IT INTO PLACE- THE CARPET WILL INTERFERE SLIGHTLY BUT CAN BE COMPRESSED BY THE BRACKET WITHOUT DAMAGING IT.
3. LOWER SEAT INTO POSITION, ENSURING THAT THE SEAT BRACKET HOLE IS CENTERED OVER THE BASE BRACKET HOLE.
4. REINSTALL OEM FRONT SEAT BOLT AND TIGHTEN TO VEHICLE MANUFACTURER'S TORQUE SPECIFICATION.
5. IF DISASSEMBLY OF THE ARM ASSEMBLY IS DESIRED, ADDITIONAL 5/16-24 LOCKING NUTS ARE INCLUDED

ITEM NO.	QTY.	PART NUMBER	DESCRIPTION
1	1	10-006037	BRKT, FLEX ARM MOUNT, TOP
2	1	10-008607	BRKT, FAM, NISSAN FRONTIER
3	1	30-006083	ARM ASSEMBLY, FLEX ARM MOUNTS
4	4	GSM30027	NUT 8-32 KEPS ZP
5	3	GSM30028	NUT 10-32 KEPS ZP, BLK
6	2	GSM30160	HRDW.NUT,LOCK,5/16-24,ZINC,SP
7	3	GSM30160	HRDW.NUT,LOCK,5/16-24,ZINC,SP
8	4	GSM31006	WASHER, 5/16" FLAT, SAE ZP
9	2	GSM31020	WASHER 5/16 x 2 FENDER ZP
10	4	GSM33540	SCREW 8-32 X 3/8 PTHMS ZP
11	2	GSM33807	HRDW,SCRW,5/16-24X1 GR5,ZPS
12	3	GSM34096	SCREW, 10-32 X 3/8 PPHMS SS
13	1	C-FAM-201	FLEX ARM MOUNT, 14" LG

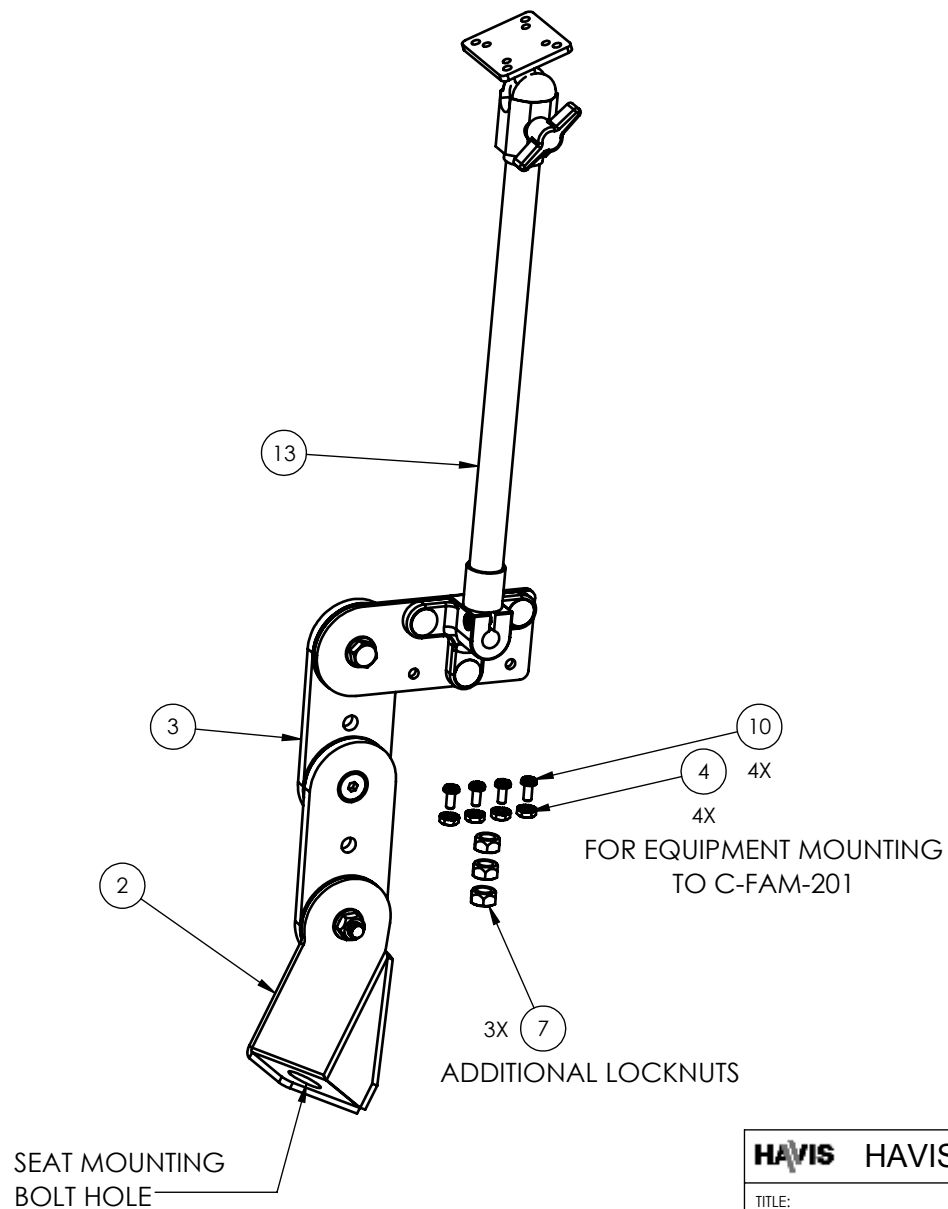

**HAVIS** HAVIS, INC.

TITLE:  
INSTALLATION INSTRUCTIONS,  
C-FAM-117

**DO NOT SCALE DRAWING**

SIZE <b>A</b>	DWG. NO. C-FAM-117-INST	REV 3-17
------------------	----------------------------	-------------

WEIGHT (LB): 3.98

SCALE: 1:4

SHEET 1 OF 1

## INSTALLATION INSTRUCTIONS

PROJECT #	REV.	DESCRIPTION	DATE	BY	CHECKED BY
1349	8-14	CHG LETTER REV. TO DATE	8/12/2014	KDAVIS	

### INSTALLATION OF C-FAM-201 PRIOR TO VEHICLE INSTALLATION (PKG-FAM-1XX ONLY):

1. ASSEMBLE FLEX MOUNT (C-FAM-201), SCREWING SHAFT INTO MOUNTING BASE AS SHOWN IN ILLUSTRATION. SECURE WITH INCLUDED 10-32 SOCKET HEAD CAP SCREW AND INCLUDED ALLEN WRENCH (NOT SHOWN)
2. ATTACH FLEX MOUNT TO BRACKET WITH 3 OF 10-32 X 3/8"SCREWS AND KEPS NUTS. **NOTE:** ON C-FAM-101 NO NUTS RE REQUIRED, 10-32 SCREWS ARE 1/4" LENGTH.
3. INSTALL INCLUDED CAPS AFTER TIGHTENING HARDWARE (IF DESIRED).

### VEHICLE INSTALLATION (EXCEPT C-FAM-101):

4. REMOVE PLASTIC SEAT TRIM IF NEEDED.
5. REMOVE PASSENGER SIDE INBOARD FRONT SEAT BOLT.
6. SLIDE BASE PLATE IN BETWEEN FLOOR AND SEAT BRACKET OR PLACE OVER SEAT BOLT HOLE AS NEEDED.
7. REINSTALL OEM SEAT BOLT, OR REPLACEMENT BOLT AND SPACER (IF SUPPLIED) AND TIGHTEN TO VEHICLE MANUFACTURER'S TORQUE SPECIFICATION.

### EQUIPMENT INSTALLATION

1. ATTACH EQUIPMENT TO UPPER BALL SWIVEL OF FLEX MOUNT USING EITHER SUPPLIED #8 SCREWS AND/OR NUTS OR HARDWARE SUPPLIED WITH THE EQUIPMENT.
2. POSITION EQUIPMENT AS DESIRED.

### INSTALLATION TIPS/ NOTES:

1. SWIVEL DISCS CAN BE RECONFIGURED IF DESIRED, BUT NEW CONICAL LOCKING NUTS SHOULD BE USED IF ORIGINAL NUTS HAVE BEEN REMOVED.
2. COMPLETELY TIGHTENING THE LOWER DISCS (TO LOCK IN POSITION) IS RECOMMENDED TO MINIMIZE SWIVEL/ HINGE MOVEMENT.
3. BALL MOUNT HOLE PATTERN FITS 1.19 X 1.50 (30MM X 38MM) AMPS HOLE PATTERN.
4. C-FAM-201 CAN ATTACH TO EITHER SIDE OF PLATE (AS DESIRED)

ISOMETRIC VIEW  
FOR REFERENCE ONLY

ADDITIONAL  
LOCKING NUTS

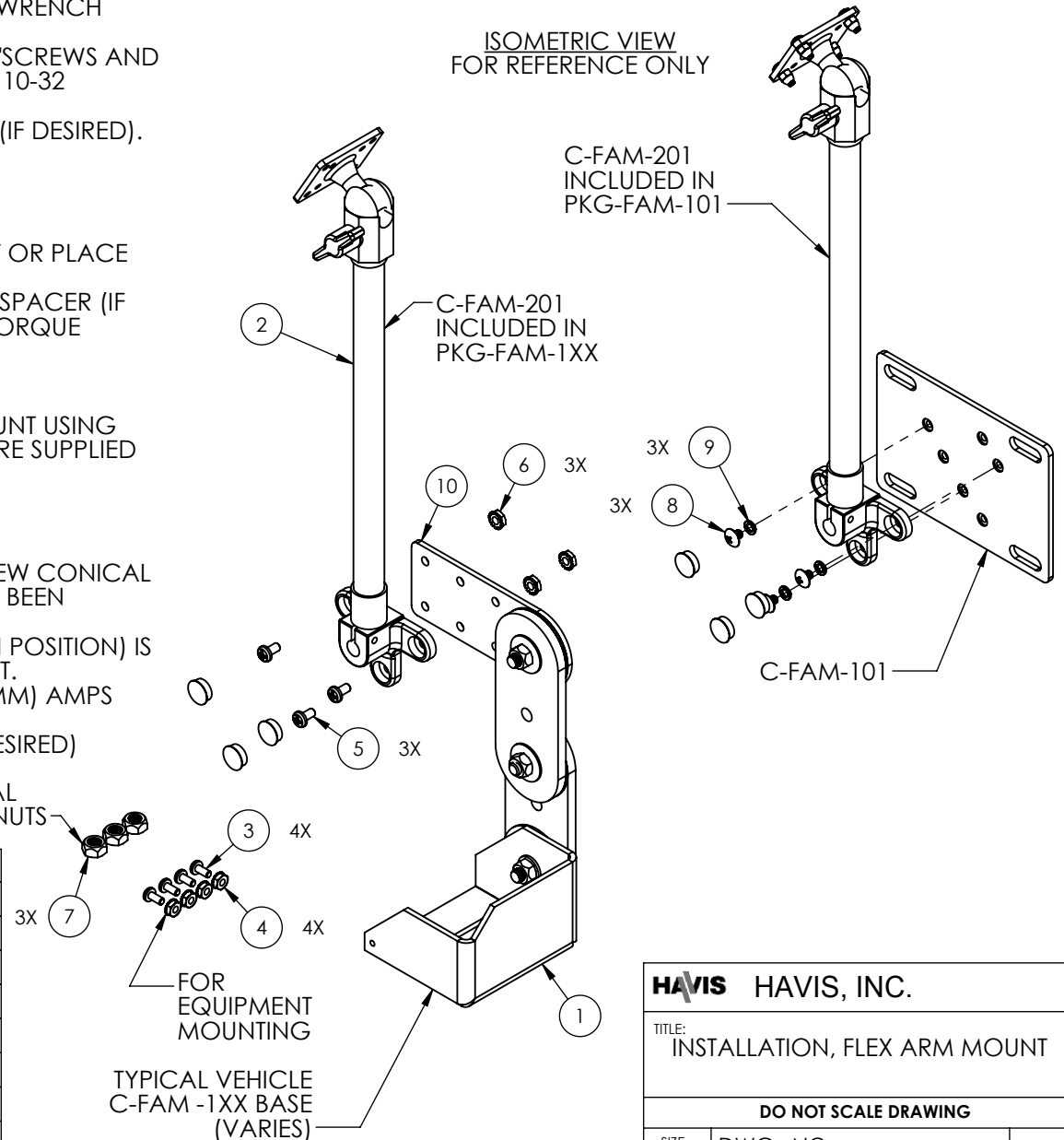

ITEM NO.	QTY.	HK	PART NUMBER	DESCRIPTION
1	1		C-FAM-1XX	BRKT, FLEX ARM MOUNT, 2013 FUSION/ INSE
2	1	1	C-FAM-201	FLEX ARM MOUNT, 14" LG
3	4	4	GSM33540	SCREW 8-32 X 3/8 PTHMS ZP
4	4	4	GSM30027	NUT 8-32 KEPS ZP
5	3	3	GSM34096	SCREW, 10-32 X 3/8 PPHMS SS
6	3	3	GSM30028	NUT 10-32 KEPS ZP, BLK
7	5	3	GSM30160	HRDW,NUT,LOCK,5/16-24,ZINC,SP
8	3	3	GSM33320	HRDW,SCRW,10-32x1/4,PTHMS,ZINC, (FAM-101 ONLY)
9	3	3	GSM31025	WASHER #10 LOCK ZP (FAM-101 ONLY)
10	1	1	10-006037	BRKT, FLEX ARM MOUNT, TOP

**HAVIS** HAVIS, INC.

TITLE:  
INSTALLATION, FLEX ARM MOUNT

DO NOT SCALE DRAWING

SIZE	DWG. NO.	REV
<b>A</b>	C-FAM-INST	8-14
WEIGHT (LB): 2.77	SCALE: 1:4	SHEET 1 OF 2

**C-FAM-101  
OPTIONAL INSTALLATION  
EXAMPLES**

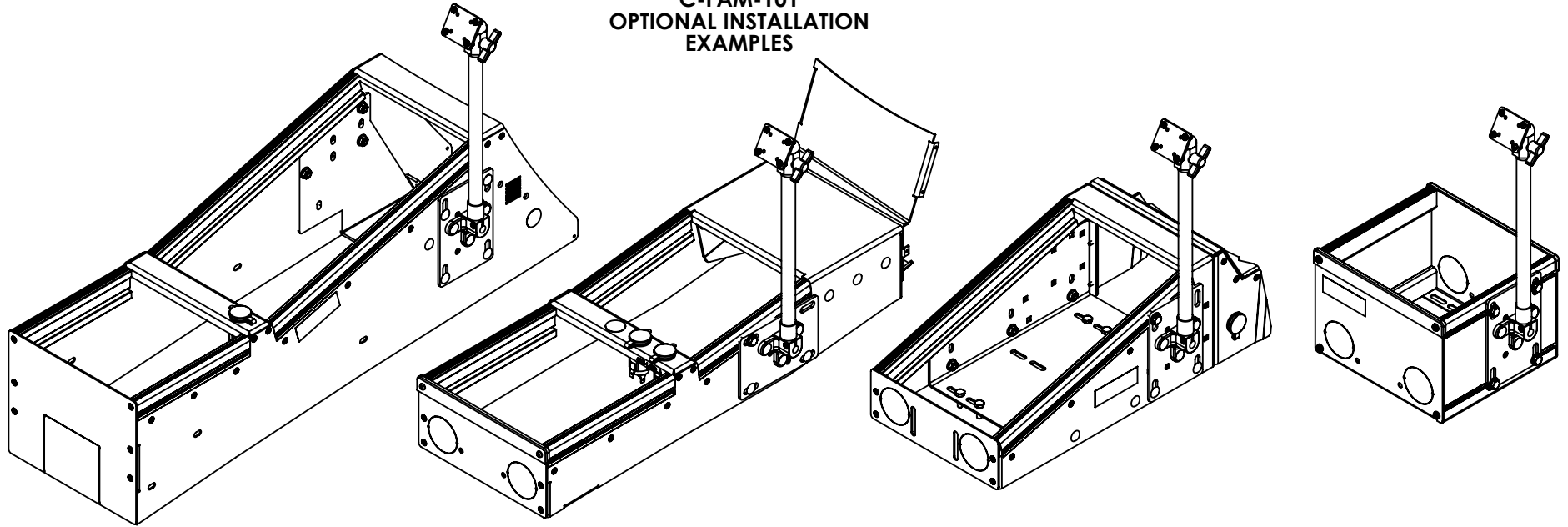

**C-FAM-101 UNIVERSAL FLEX ARM MOUNT  
CONSOLE INSTALLATION:**

1. MOST HAVIS CONSOLES HAVE A MATCHING MOUNTING BOLT PATTERN ON THE PASSENGER SIDE. PLACE THE FLEX ARM MOUNTING PLATE ON THE SIDE OF THE CONSOLE AND FIND A MATCHING MOUNTING PATTERN.
2. IN SOME CONSOLES, IT MAY BE NECESSARY TO USE ONE OF THE NUTS PREINSTALLED IN THE SIDE OF THE TOP RAIL FOR THE TOP REAR FASTENER. INSTALLER MAY NEED TO DRILL ONE OR MORE MOUNTING HOLES IN THE EVENT THAT MATCHING PREDRILLED HOLES IN THE CONSOLE CANNOT BE FOUND.
3. SECURE C-FAM-101 MOUNTING PLATE TO SIDE OF CONSOLE WITH 1/4-20 X 3/4" LONG CARRIAGE BOLTS AND FLANGED NUTS.

**EQUIPMENT INSTALLATION:**

1. ATTACH EQUIPMENT TO UPPER BALL SWIVEL OF FLEX MOUNT USING EITHER SUPPLIED #8 SCREWS AND/OR NUTS OR HARDWARE SUPPLIED WITH THE EQUIPMENT.
2. POSITION EQUIPMENT AS DESIRED.

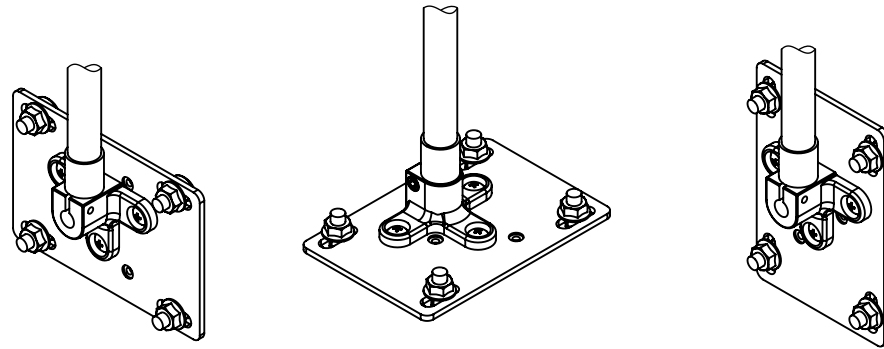

<b>HAVIS</b> HAVIS, INC.		
TITLE: INSTALLATION, FLEX ARM MOUNT		
<b>DO NOT SCALE DRAWING</b>		
SIZE <b>A</b>	DWG. NO. C-FAM-INST	REV 8-14
WEIGHT (LB): 0.88	SCALE: 1:4	SHEET 2 OF 2