



Part # S4006BKE

This high quality [rocker kit](#) includes heavy wall, specially hardened rocker shafts, bronze bushed roller rockers with adjusters & 12pt. jam nuts, billet steel stands and spacers. For ease of installation we included a diagram of the rocker assembly with proper placement of the components.

Edelbrock Head

Stock Head 390-427-428

Colored arrows indicate where the shims need to be for the Edelbrock & Stock head 390-427-428

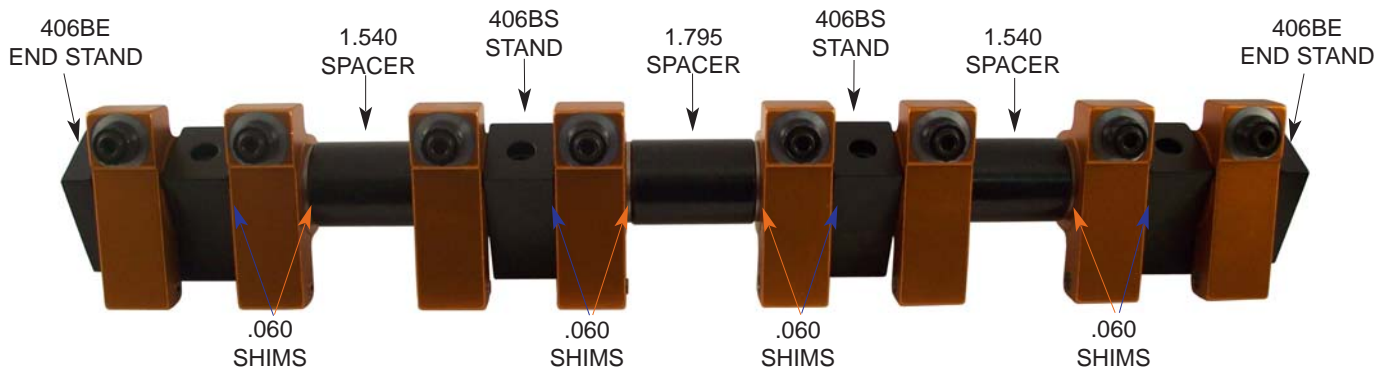

Replacement Parts:

- 16 pcs. - 4006B-1 rocker arms
- 2 - 4006S-1 shafts (.840 dia.)
- 1 - 406BSK stands (4 pcs.)
- 1 - 406BSPK spacer kit (10 pcs.)
- 1 - 406BEK end stands (4 pcs.)
- 4 - FA716K adjusters & nuts (16 pcs.)

Spacers may need trimmed. **Make sure the oil holes in the shaft are on the bottom side of the rockers.**

HS also recommends the following installation tips.

- For Edelbrock head install .060 shim between Int rocker & stand
- Oil adjusters and install into rockers before bolting to engine. Leave adjusters loose.
- Apply oil or lube to roller tip and pushrod ball before installing on engine or allow rocker assembly to soak in 30W oil for 1/2 hour prior to install.
- You want approximately .008 to .012 clearance gap per cylinder (bolt to bolt)
- Torque rocker hold down bolts to 25 ft. lbs.
DO NOT OVERTIGHTEN!
- Hand tighten adjuster jam nut or do not exceed 18-20 ft. lbs.
DO NOT OVERTIGHTEN!

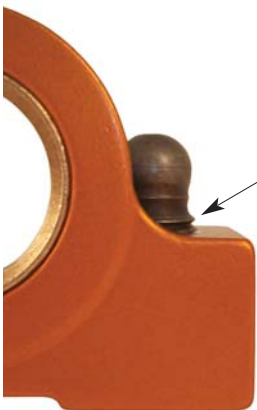

The rocker adjusters are a 7/16-20 screw with a 3/8 ball. You have to use pushrods with a 3/8 cup end. When setting pushrod length have no more than 2 and no less than 0 threads showing on the bottom side of the rocker, between the ball and rocker body. This is to make sure the pushrod contact point and rocker geometry are correct.