



**Please Note:** These instructions are provided as a general guideline only. Specific mounting, wiring, and/or weather-sealing may be necessary and are the sole responsibility of the installer. The manufacturer assumes no responsibility for the integrity of the installation for this or any of its products.



Please review all of the following requirements prior to installing the this light. Failure to follow these safety precautions and instructions could result in damage to the product or vehicle and could result in serious injury to you and your passengers.

- Improper installation may result in serious injury, property damage, or death. The installer must have a good understanding of automotive electronics, systems, and procedures.
- If you are drilling any holes while mounting this light, please be sure to check both sides of the surface to ensure that you do not damage anything. De-burr all holes.
- Ensure that any switches used are located in an area that allows the vehicle and device to be operated safely in any driving condition.
- Use a minimum 18AWG wire for electrical connections and a 5A fuse at the power source, ensuring both positive and ground connections are dependable.
- Test the light and inspect all wiring each time you use the vehicle to ensure that it is functioning properly. If it is not functioning properly, do not operate the vehicle!!
- Use only soap and water to clean this product. Use of harsh chemicals could cause the domes to haze and may lead to diminished light output reducing the effectiveness. Do not use a power washer to clean this product.



This light uses high-intensity LEDs. DO NOT stare directly into the light while it is on, as momentary blindness and/or permanent eye damage may occur.

## Mounting

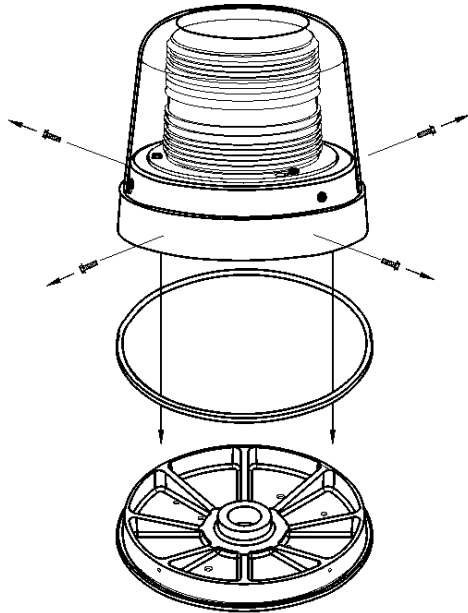

1. Remove the four screws in the side of the aluminum housing.
2. Slide the plastic base out of the aluminum case. Do not damage the gasket !!
3. Determine which knockouts on the base will work best for your application and clear them using a punch or other appropriate tool.
4. Using the plastic mounting base as a template, mark the appropriate holes on the mounting surface.
5. Drill a 3/8" hole in the marked locations. Then, if applicable, drill a 3/8" hole for the wires in the center of the outer holes.  
**CAUTION: Take care not to drill through the headliner of the vehicle below.**
6. Insert the rubber well nuts into the mounting holes so the wider lip rests on the mounting surface.
7. Route the wires through the center hole and install the screws through the base, into the well nuts, and tighten until snug.
8. Place the light on the base and reinstall the four screws.

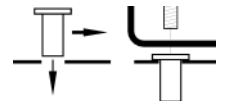
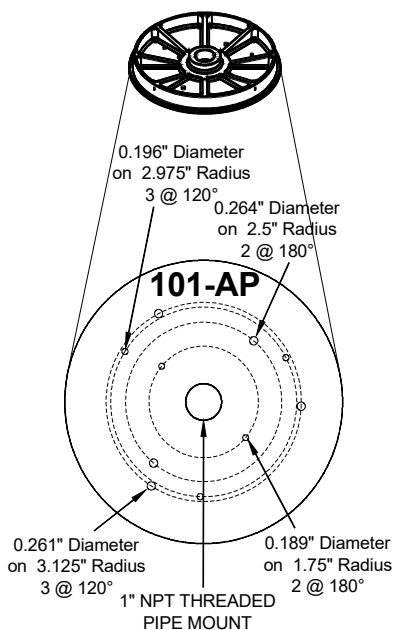

# Wiring



All of our DC powered warning lights are polarity sensitive. These lights are polarity protected *only if the appropriate fuse is used*. All wires connected to the positive terminal of the battery should be fused at the battery for their rated load. **Testing the light before this fuse is properly installed will void the warranty on the light.**

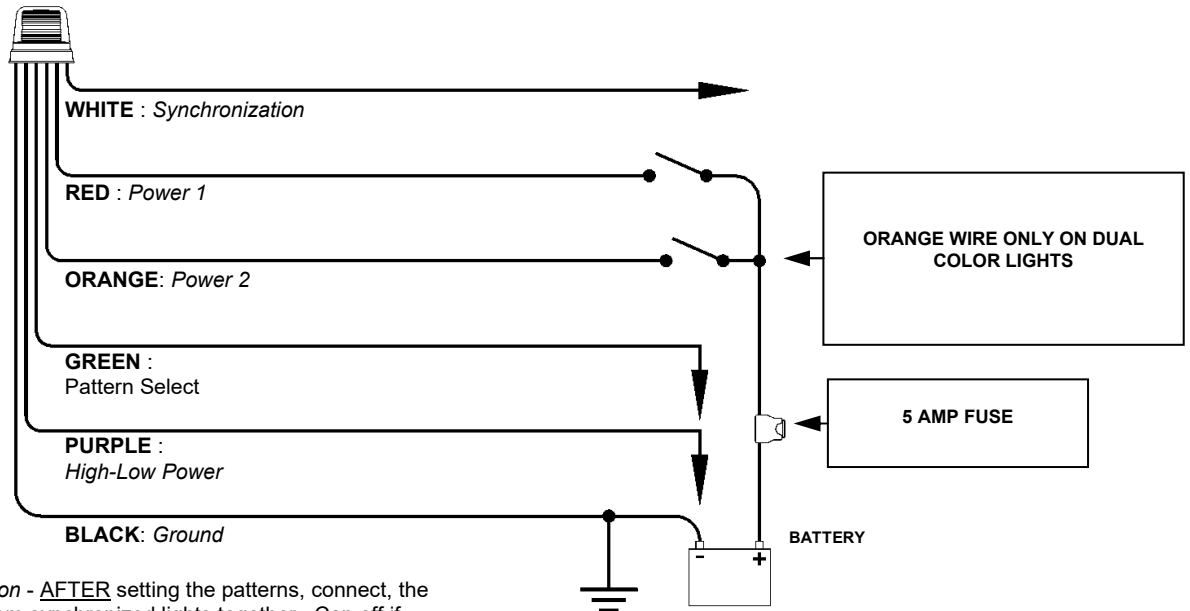

**WHITE:** *Synchronization* - AFTER setting the patterns, connect, the white wires from synchronized lights together. Cap off if not used.

**GREEN:** *Pattern Select* - Touch and release to Ground to change

**RED:** *Power 1* - Connect to +12-24VDC through your switch

**PURPLE:** *High/Low Power* - Ground for Low / Open for High

**ORANGE:** *Power 2* - Connect to +12-24VDC through your switch using a 5 amp fuse.

**BLACK:** *Ground* - Connect to a Good Chassis Ground or the

## High/Low Power Settings (single color lights only)

- **High Power Only:** Cut the Purple wire short and cap off.
- **Low Power Only:** Connect the Purple wire to Ground.
- **Manually Switched High/Low Power:** Connect the Purple wire to Ground through a switch.

# Pattern Programming

1. Power up the light by connecting the red wire to power and the black wire to ground.
2. Touch and release the green wire to ground to cycle through the patterns.
3. After the pattern has been set, place a wire nut over the end of the green wire to prevent it from coming into contact with ground again.

| Phase 1 Flash Pattern # | Phase 2 Flash Pattern # | Pattern Type | Pattern Description           | CPS | Phase 1 Shortcut                | Phase 2 Shortcut                 |
|-------------------------|-------------------------|--------------|-------------------------------|-----|---------------------------------|----------------------------------|
| 1                       | 13                      | K            | Flicker †                     | 1   | 3 Sec/1 Blink<br>(Dual Color)   | 9 Sec/3 Blinks<br>(Dual Color)   |
| 2                       | 14                      | L            | Fast Doubleflash              | 3.3 |                                 |                                  |
| 3                       | 15                      | M            | Tripleflash †                 | 2.5 |                                 |                                  |
| 4                       | 16                      | A5           | CCW Rotation 1 †              | 1.3 | 3 Sec/1 Blink<br>(Single Color) | 9 Sec/3 Blinks<br>(Single Color) |
| 5                       | 17                      | A6           | CCW Rotation 2                | 2.7 |                                 |                                  |
| 6                       | 18                      | F            | Quadflash † (Default Pattern) | 1   | 6 Sec/2 Blinks                  | 12 Sec/4 Blinks                  |
| 7                       | 19                      | G            | Quadflash w/Post-Pop †        | 1   |                                 |                                  |
| 8                       | 20                      | H            | Singleflash †                 | 1   |                                 |                                  |
| 9                       | 21                      | I            | Doubleflash †                 | 1   |                                 |                                  |
| 10                      | 22                      | J            | Variable AKA Delta-Omega      | 0.3 |                                 |                                  |
| 11                      | 23                      | C            | Post pop 1.4CPS †             | 1.4 |                                 |                                  |
| 12                      | 24                      | E            | Random 0.4CPS                 | 0.4 |                                 |                                  |
| NA                      |                         | Steady       |                               | NA  | 18 Sec/5 Blinks                 |                                  |

† - Approved patterns for SAE J845 when properly configured

## **SHORTCUTS:**

Hold the green wire to ground for the indicated amount of time to go directly to the desired pattern.

# Synchronization

You can synchronize up to six total  approved lights.



**DO NOT CONNECT WHITE WIRES UNTIL PROGRAMMING HAS BEEN COMPLETED FOR ALL LIGHTS!!**

1. Program the first unit.
2. Program the second light with the same **Pattern Type**.
  - Lights with the SAME phase flash together (simultaneous).
  - Lights with DIFFERENT phases flash opposite one another (alternate).

3. After programming all lights, cap off the g
4. With the power off, connect the white wires together.
5. Test the lights by applying power to all of them at the same time.

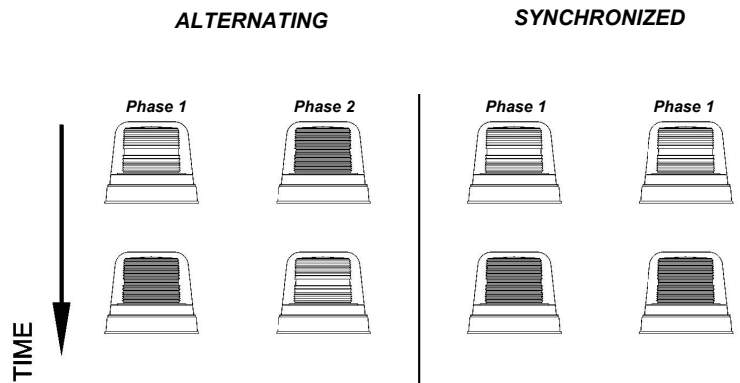

# Low Voltage Detection

If the battery voltage becomes low (less than 10V), the beacon will enter a mode where it will continually flicker. Once the input voltage returns to normal (greater than 12V) the unit will return to the normal flashing.