



**Installation Guide:
Mini-Lightbar
Model 77003**

Safety First

This document provides all the necessary information to allow your Grote® product to be properly and safely installed. Before beginning the installation and/or operation of your new product, the installation technician and operator must read this manual completely. Important information is contained herein that could prevent serious injury or damage.

- **Proper installation of this product requires the installer to have a good understanding of automotive electronics, systems and procedures.**
- **If mounting this product requires drilling holes, the installer MUST be sure that no vehicle components or other vital parts could be damaged by the drilling process. Check both sides of the mounting surface before drilling begins. Also de-burr the holes and remove any metal shards or remnants. Install grommets into all wire passage holes.**
- **If this manual states that this product may be mounted with magnets or any other temporary mounting style, clean the mounting surface with a 50/50 mix of isopropyl alcohol and water and dry thoroughly.**
- **DO NOT INSTALL THIS PRODUCT OR ROUTE ANY WIRES IN THE DEPLOYMENT AREA OF YOUR AIR BAG. EQUIPMENT MOUNTED OR LOCATED IN THE AIR BAG DEPLOYMENT AREA WILL DAMAGE OR REDUCE THE EFFECTIVENESS OF THE AIR BAG, OR BECOME A PROJECTILE THAT COULD CAUSE SERIOUS PERSONAL INJURY OR DEATH. REFER TO YOUR VEHICLE OWNERS MANUAL FOR THE AIR BAG DEPLOYMENT AREA. THE USER/INSTALLER ASSUMES FULL RESPONSIBILITY TO DETERMINE PROPER MOUNTING LOCATION, BASED ON PROVIDING ULTIMATE SAFETY TO ALL PASSENGERS INSIDE THE VEHICLE.**
- **For this product to operate at optimum efficiency, a good electrical connection to chassis ground must be made. The recommended procedure requires the product ground wire to be connected directly to the NEGATIVE (-) battery post (this does not include products that use cigar power cords).**
- **If this product uses a remote device for activation or control, make sure that this device is located in an area that allows both the vehicle and the device to be operated safely in any driving condition.**
- **Do not attempt to activate or control this device in a hazardous driving situation.**
- **This product contains either strobe light(s), halogen light(s), high-intensity LEDs or a combination of these lights. Do not stare directly into these lights. Momentary blindness and/or eye damage could result.**
- **Use only soap and water to clean the outer lens. Use of other chemicals could result in premature lens cracking (crazing) and discoloration. Lenses in this condition have significantly reduced effectiveness and should be replaced immediately. Inspect and operate this product regularly to confirm its proper operation and mounting condition. Do not use a pressure washer to clean this product.**
- **It is recommended that these instructions be stored in a safe place and referred to when performing maintenance and/or reinstallation of this product.**
- **FAILURE TO FOLLOW THESE SAFETY PRECAUTIONS AND INSTRUCTIONS COULD RESULT IN DAMAGE TO THE PRODUCT OR VEHICLE AND/OR SERIOUS INJURY TO YOU AND YOUR PASSENGERS!**

Permanent Mounting:

1. Locate the mounting foot and mounting plate included with your lightbar. If not already present, install the plate onto the mounting foot. When properly positioned, this plate is centered from side to side on the mounting foot.
2. Flip the lightbar upside-down to expose the bottom of the extrusion and place the mounting foot onto the extrusion.
3. Rotate the mounting foot 90° counter-clockwise. Make sure that the edges of the mounting foot swing into position under the extrusion mounting lip.
4. Repeat this procedure for the remaining mounting foot and return the lightbar to its right side-up position.
5. Position the lightbar onto the vehicle roof in the desired mounting location. One often selected location is directly above the B-pillars. This area is the strongest part of the roof. Refer to your lightbar manual for your lightbar cable exit location, to be sure that the lightbar is facing the proper direction.
6. Adjust the two mounting feet outwards so that they are as close to the edge of the roof as possible. Make sure that both mounting feet are in full contact with the roof. Be sure that there is no less than 1/2" clearance between the roof and the lightbar at their closest point. When the mounting feet are in their proper position, lightly tighten the mounting foot allen head set screws.
7. Turn the lightbar upside down and firmly tighten all of the set screws from step 6 (2 or 4 per side).
8. On the mounting foot, remove either the two outer or inner rubber mounting pads. Carefully remove the mounting pad's guide dart so the hole through the center of the pad is exposed then replace the pad (Standard foot only). On the adjustable foot, use the hole in the pad as a guide to drill the two holes into the mounting foot.
9. Place the lightbar in its final mounting position on the vehicle, mark the mounting hole locations off onto the mounting surface, remove the lightbar and drill the mounting holes.

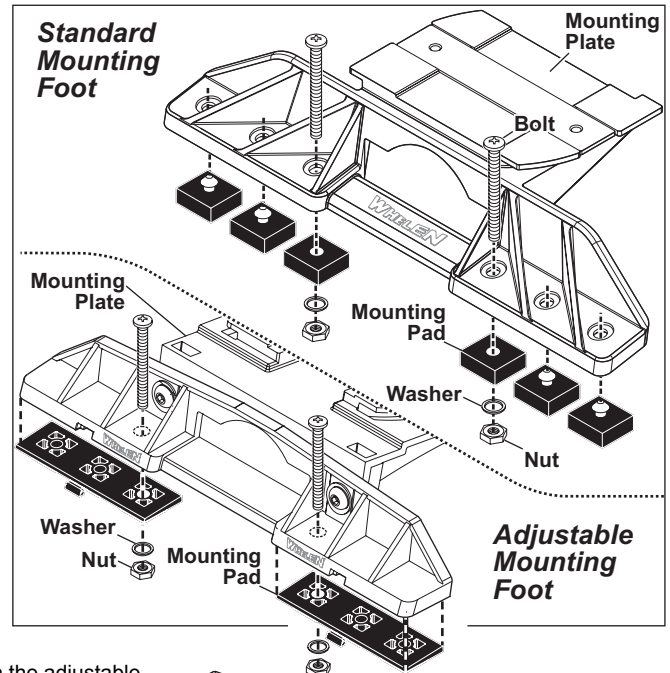

10. Place the lightbar lined up with the mounting holes and secure the mounting feet to the vehicle using the supplied hardware.

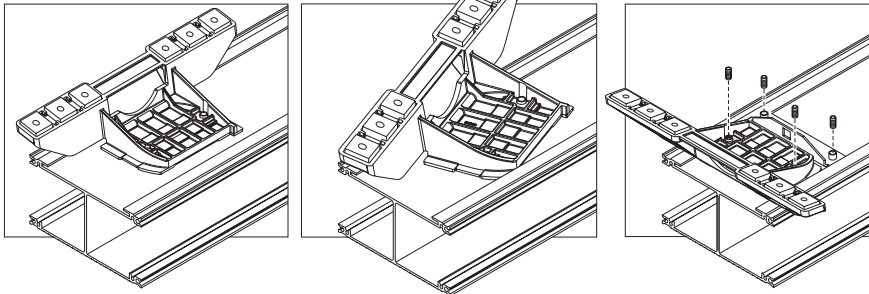

Slide Bolt Mounting (Permanent):

This lightbar mounts with 4 bolts affixed to mounting plates that slide into the track on the bottom of the lightbar base. The illustration below shows how the slide bolt assembly slides into your lightbars base and mounts onto the vehicle. Use an appropriately sized drill bit sized for a 1/2" - #13 X 2" bolt, to drill the mounting holes.

1. Insert slide bolts into base, slide them across to their mounting position and secure with set screws.
2. Position the lightbar onto the vehicle and mark the four bolt hole locations onto the mounting surface.
3. Drill the 4 holes with a drill bit sized for the bolts.
4. Replace end cap and insert bolts into their 4 mounting holes and secure the lightbar with supplied hardware.

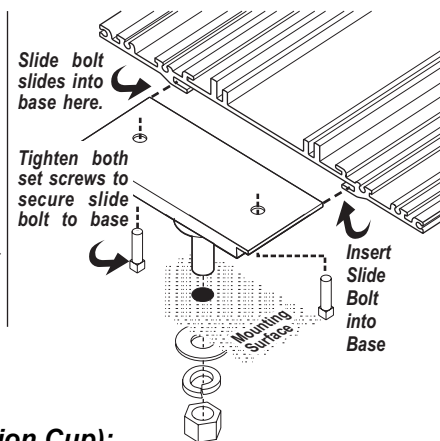

NOTE: Model MKAJ is an adjustable mounting foot. On this model you may loosen the screws on the rear of the foot and adjust the angle of the lightbar. This feature can be used if the angle of the roof is not level with the road.

IMPORTANT: To tighten the leveling screws you must use a torque wrench set at 35 to 40 ft. lbs.

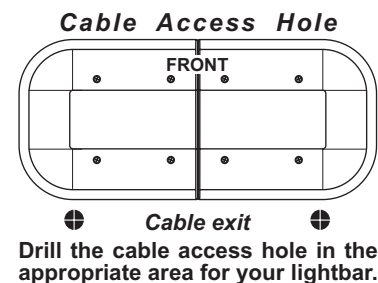

Temporary Mount (Magnetic, Suction Cup):

WARNING: The use of any magnetically mounted warning device on the outside of a vehicle in motion is not recommended and is at the sole risk and responsibility of the user.

Magnetic/suction: Thoroughly clean the proposed mounting surface prior to mounting. For suction cup mounting, wipe the suction cup clean, place the beacon onto its mounting surface and apply gentle pressure to ensure a good seal has been achieved. The Magnetic/Suction Cups mount the same way as standard suction cups but are best suited to a flat, steel surface. **Magnetic:** Place the lightbar onto the mounting surface and plug it into the vehicle cigar lighter.

Lightbar Cable:

The standard lightbar uses an 11 conductor cable for LED's and Halogens as well as power and function. Extend the cable towards your switch panel and follow the switch panel instructions for wiring connections. Cigar cord models do not offer Low Power or Pattern Override. Scan-Lock™ is controlled by a momentary switch on the cigar plug.

WARNING! All Customer supplied wires that connect to the positive terminal of the battery must be sized to supply at least 125% of the maximum operating current and FUSED at the battery to carry that load. DO NOT USE CIRCUIT BREAKERS WITH THIS PRODUCT!

WHITE/VIOLET: Scan-Lock™

LED's must be on for Scan-Lock™ to work.

TO CHANGE PATTERNS: To cycle forward to the next available pattern: Apply +12 volts to the WHT/VIO wire for less than 1 second and release. To cycle back to the previous pattern: Apply +12 volts to the WHT/VIO wire for more than 1 second and release.

TO CHANGE THE DEFAULT PATTERN: When the desired pattern is active, allow it to run for more than 5 seconds. The lightbar will now display this pattern when activated.

TO RESTORE THE FACTORY DEFAULT PATTERN: With power to the lightheads off, apply +12 volts to the WHT/VIO wire. While still applying +12 volts to the WHT/VIO wire, turn power to the lightheads back on. The factory default pattern should now be displayed.

A Normally Open momentary switch can be used to control Scan-Lock™ operation. Cigar cord models have a switch on the cigar plug.

Violet / Low Power:

The type of switch used depends on how you wish Hi/Lo to function:
Latching Mode: By applying positive voltage to the VIOLET wire for less than 1 sec., the power supply is "latched" into low power. The unit must be turned off and then back on to restore normal, Hi power operation. (A momentary switch is recommended)

Level Mode: Applying positive voltage to the VIOLET wire for more than 1 sec. holds the power supply in low power mode until voltage is removed. (A toggle switch is recommended)

MR11: Removal & Installation / Alley Light

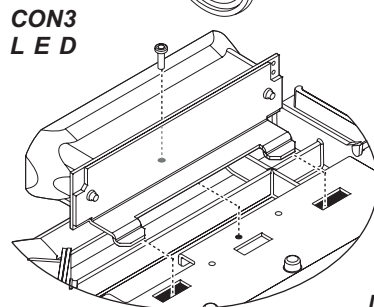
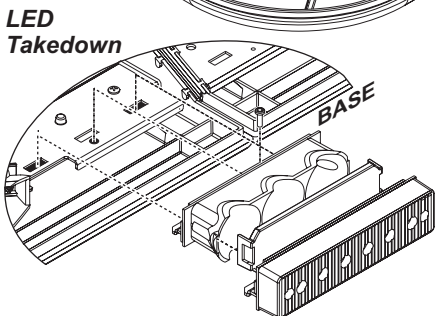
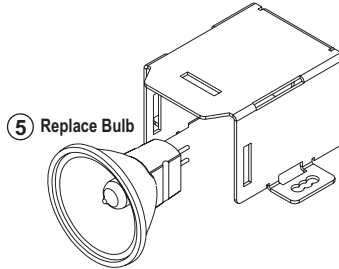
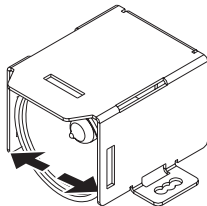
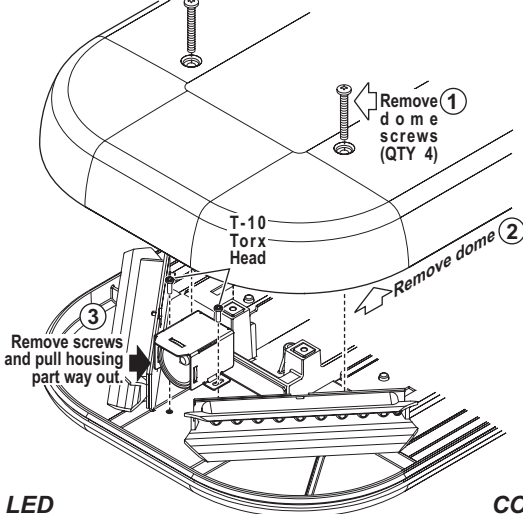

CAUTION! Do not handle the halogen bulb with bare hands. Use gloves to prevent possible injury. Replacing any halogen bulb requires the use of safety glasses to prevent injury.

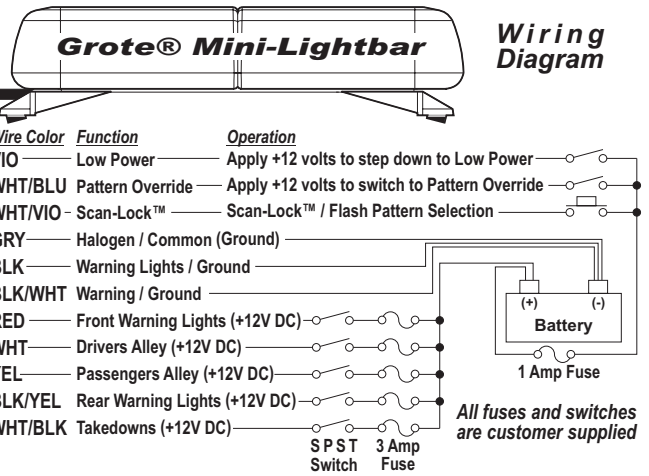
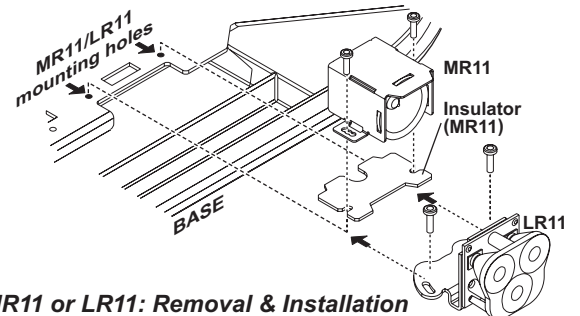
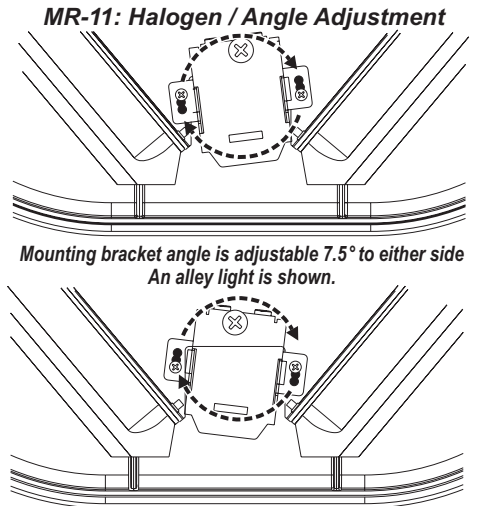

WHITE/BLUE: Pattern Override

Applying +12 volts to the WHT/BLU wire while lightheads are activated will change the flash pattern to whichever flash pattern that *pattern override* is pre-programmed for. To program *pattern override*, activate the lightbar then activate *pattern override* by applying +12 volts to the WHT/BLU wire. Now you may select a flash pattern using the Scan-Lock™ procedure.

IMPORTANT! Before returning this vehicle to active service, visually confirm the proper operation of this product, as well as all vehicle components/equipment.

IMPORTANT! It is the responsibility of the installation technician to make sure that the installation and operation of this product will not interfere with or compromise the operation or efficiency of any vehicle equipment!

IMPORTANT WARNING!
CAUTION! DO NOT LOOK DIRECTLY AT THESE LED'S WHILE THEY ARE ON. MOMENTARY BLINDNESS AND/OR EYE DAMAGE COULD RESULT!