



***Greddy***  
**Profec**  
**ELECTRONIC BOOST CONTROLLER**

instruction manual

Please read this manual thoroughly before installation and operation.

**Please read.**

Thank you very much for your recent purchase: GReddy Profec. Please read this manual thoroughly before installation and operation. We hope this instruction manual will be helpful to you whether you are a novice or a technician. This product is intended for off-road use. Please keep this manual for future reference.

◆ **Disclaimer** ◆

**Please read**

To the best of our knowledge, the information contained herein is accurate. However, neither TRUST CO., LTD or any of its subsidiaries assumes any liability whatsoever for the accuracy or completeness of the information contained herein. All materials may present unknown hazards and should be used with caution. In particular, improper use of our products and their inappropriate combination with other products and substances may produce harmful results which cannot be anticipated. Final determination of the suitability of any material is the sole responsibility of the user. Although certain hazards are described herein, we cannot guarantee that these are the only hazards that may exist. All service performed on internal parts and equipment should be provided by qualified technicians.

---

# Table of Contents

Contents	Introduction ..... <b>Please Read</b> P1
	Table of Contents ..... P2
	Disclaimers ..... <b>Please Read</b> P3~6
	Parts List ..... P7
	Product Features ..... P8
Installation	Product description / Before installation ..... <b>Please Read</b> P9
	Installation overview (Actuator type) ..... P10
	Power unit wiring instructions / Pressure sensor hose routing instructions .. P11
	Installing the solenoid valve unit ..... P12,13
	Installing the solenoid valve unit (Actuator type) ..... P14
	Installing the solenoid valve (External wastegate type) ..... P15
Operations	Control unit installation ..... P16
	Basic operation ..... <b>Please Read</b> P17
	Operating instructions ..... P17,18
Configurations	Quick reference matrix ..... P19,20
	SET UP overview ..... P21
	PATTERN ..... P22
	DIRECTION / BRIGHT ..... P23
	UNIT / ALARM ..... P24
	LAST BOOST ..... P25
	START TYPE ..... P26
DATA LOCK ..... P27,28	
Boost settings	Programming overview ..... P29
	SET ..... P30
	GAIN ..... P31
	START BOOST ..... P32
	PEAK ..... P33
	WARNING ..... P34
	LIMITER ..... P35
	SCRAMBLE ..... P36
SWITCH MODE ..... P37	
Troubleshooting	Short cut commands ..... P38
	Troubleshooting / Test mode ..... P39
	Boost setting tips ..... P40
	Factory default settings / Trouble shooting ..... P41
Service ..... P42	

Contents

Installation

Operations



Configurations

Boost settings

Troubleshooting

These instructions are intended for qualified personnel only.

To reduce the risk of electrical shock, do not perform any servicing other than that contained in the Installation and Troubleshooting Instructions unless you are qualified to do so. Refer all servicing to qualified service personnel.

 Warning	This symbol indicates that hazards are present within the equipment. These hazards may be of sufficient to cause serious bodily injury if installed improperly. The symbol may also appear on schematics.
 Caution	The exclamation point, within an equilateral triangle, is intended to alert the user to the presence of important installation, servicing, and operating instructions in the documents accompanying the equipment.
Important	Precautions before installation. The word may also appear on schematics.







---



## Warning

- ⚠ Installation and tuning of this product should only be performed by a trained specialist who is very familiar with the automobile's mechanical, electrical and fuel management systems. If installed by an untrained person, it may cause damage to the unit as well as the vehicle.
- ⚠ Do not work on a vehicle that has recently been shut off. The exhaust system may be extremely hot and could cause burn injury.
- ⚠ Professional installation is recommended. There is a risk of injury if performed by an untrained person.
- ⚠ Be sure to inspect and examine all mounting surfaces and locations. Improperly mounted controllers can fall while driving the vehicle. This could cause serious injury or damage.
- ⚠ Do not attempt to operate the product while driving. Doing so may cause an accident.
- ⚠ Before moving the vehicle, make sure that your work area is clear of tools and is safe to drive through. Make sure that there are no tools or objects in the car that will keep you from operating the vehicle in a safe manner.
- ⚠ Make sure that the installation of fuel sensors is done somewhere that is well ventilated. Fuel is flammable and may cause serious injury if not handled properly.
- ⚠ When using soldering irons and nippers, please read their operating manuals prior to use. Improper use of this equipment may lead to injury or illness.

 Caution

-  Increasing boost levels is a practice that is not advised by original equipment automobile manufacturers. While doing so will lead to more power output, it can very well lead to engine damage or complete engine failure if done improperly. The addition of more power to any vehicle requires due caution while the driver becomes acclimated. TRUST Co.,LTD. and its subsidiaries are not liable for any damage or injury that may arise from the use of the device.
  
-  Depending on the vehicle, some applications will trigger a “fuel cut” when raising the boost pressure, in these circumstances, you need an e-manage or similar unit to the control fuel cut.
  
-  Incorrect wiring could lead to damage to your cars electrical system.
  
-  Be sure to verify that all the sensors are installed using sealing tape. After installation of sensors, be sure to check for leaks such as oil, coolant and/or fuel.
  
-  Do not disassemble the product. Doing so will lead to the forfeit of warranty coverage.
  
-  When making wire connections, be sure to remove the key from the ignition, and disconnect the negative terminal of the battery.
  
-  Do not install in electrically noisy environments such as ignition signal areas. This could lead to sensor glitch or malfunction.

Important

The product is for racing vehicles only.

This product is for use ONLY on vehicles with a 12V electrical system.

Please make sure to read the safety precautions described in each category.

TRUST CO., LTD      TEL : 0479 (77) 3000

3155-5 Odai Shibayama-machi Sanbu-gun Chiba, Japan 289-1605

---

# Parts List

If you find you are missing parts, please bring this to the attention of your Authorized GReddy Dealer or contact GReddy Performance Products directly.

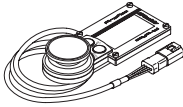

Control unit

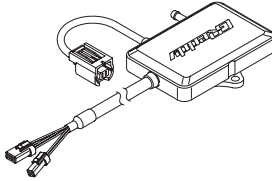

Sensor unit

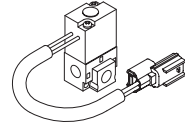

Solenoid valve unit

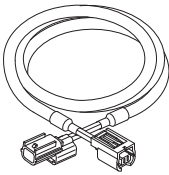

Solenoid valve harness (1.5m)

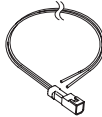

4Φ hose (1m)



4Φ hose (1m)



6Φ hose (1m)



Adjustable mounting bracket



M6 bolt x 1  
Anti-vibration isolator x 2

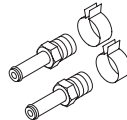

6Φ hose fitting x 2  
Hose clamp x 2

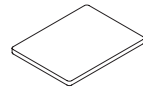

Double-sided tape

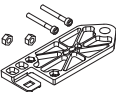

Valve unit bracket  
M4 bolt & nut x 2

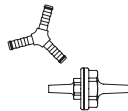

"Y" connector  
Air filter



Instruction manual



## Product Features

- Utilizes OLED (organic light-emitting diode) display for improved viewing angles & brightness.
  - Monitor boost pressure in real time. 3 selectable display patterns for boost pressure
  - By separating the Control unit from the Power unit, the Profec greatly improves the installation process.
  - Additional flush mounting options due to the thin 11mm thick design.
  - 180-degree rotatable display screen for flexibility in the layout of controls and installation options.
  - High-performance pressure sensor supports up to 300kPa (43.5psi).
  - High capacity compact solenoid valve and the new CPU increase the speed of the controller.
  - Configurable boost modes: LO, HI, and SCRAMBLE.
  - Adjustable SET%, START BOOST and GAIN% settings ensure stable boost curves.
  - Warning function when exceeding the preset boost value.
  - Limiter control function: to decrease boost when above the alarm setting.
  - Last boost function: to confirm the highest boost value set in the most recent boost session.
  - Peak hold function: capable of recalling the maximum boost pressure value recorded.
  - Data lock function: to protect the programmed settings and avoid accidental changes.
-

## Product Description

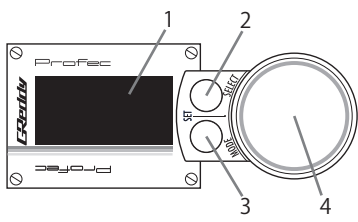

Control unit

1. Display
2. SELECT switch
3. MODE switch
4. SET DIAL

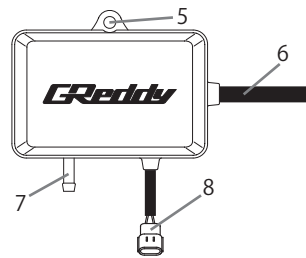

Power unit

5. Mounting flange
6. Main harness
7. Boost Pressure Sensor
8. Valve unit harness connector

## Before Installation Please read carefully

### Tools & Instruments

- |   |                  |                     |
|---|------------------|---------------------|
| • Multi-meter (Over 15V measurement capability) | • 10mm wrench    | • Electrical tape   |
| • Wire cutters                                  | • Wire cutters   | • Splice connectors |
| • +Phillips and -Slotted Screwdrivers           | • Soldering iron | • Soldering iron    |
| • Pliers  | • Crimping tool  | • Cable ties        |

- Make sure that engine is cool when you begin the installation.
- Make sure that hoses are long enough to reach valve unit, before you mount it.
- Before the installation, find the locations of wastegate, boost control solenoid valve, fuel pressure regulator.

### For the technician

- Please return this manual to the customer when installation and mounting are completed.

### For the user

- When the person other than the owner uses a vehicle, please tell him/her that Profec is installed and pass this instruction manual to the person.

## Installation Overview (Actuator type)

The Profec Sensor unit is waterproof and can be safely mounted in the engine bay. Only one main harness line is required to be routed through the firewall to the driver's compartment. The control unit is only water resistant. Therefore, do not install it in a location, where it could get wet or be in excessive heat.

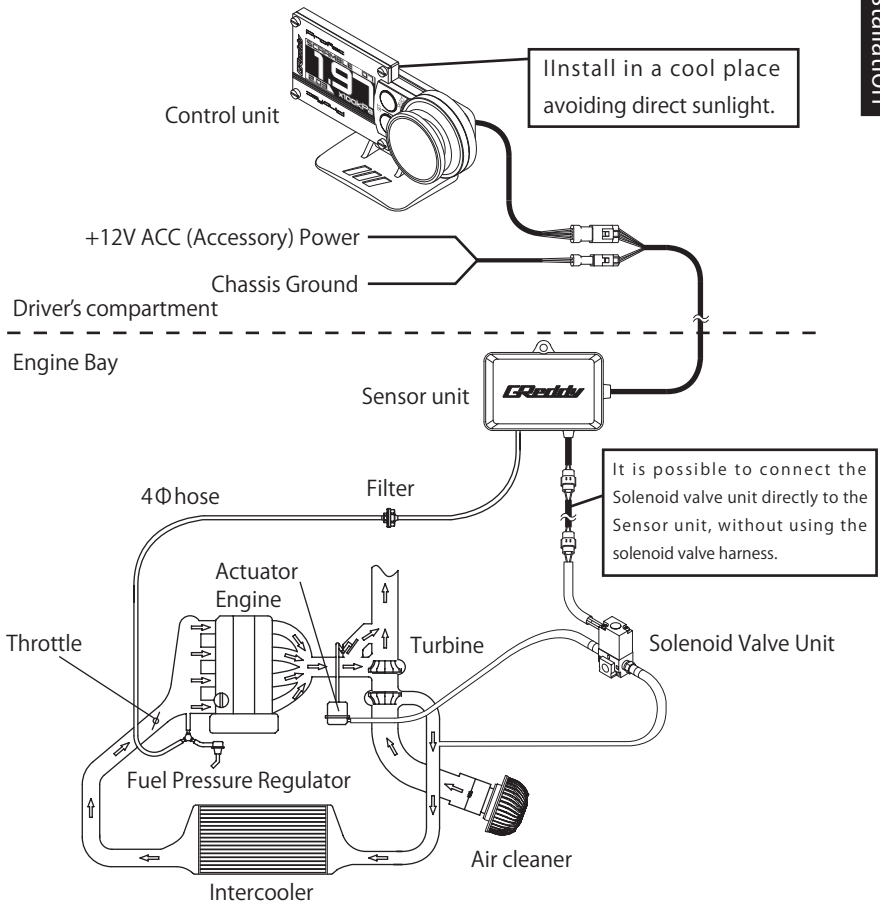

## Power unit wiring instructions

- (1) Find the (12V) ACC (Accessory) wire by using multi-meter.
- (2) Disconnect the ground wire from the battery, and solder (or use splice connector) on the ACC wire to the red wire on the power harness.
- (3) Solder (or use an electrical connector) to connect the black ground wire from Profec with a chassis ground.

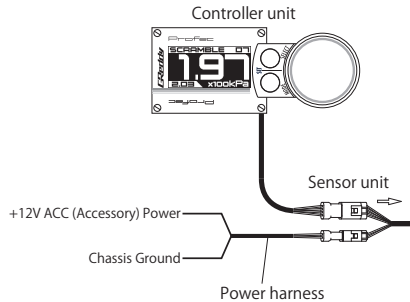

## Pressure sensor hose routing instructions

- (1) Cut the vacuum hose between intake manifold and fuel pressure regulator or between throttle and intake manifold, and connect the "Y" joint connector in between them.
- (2) Then connect the provided 4Φ hose to third opening on the "Y" joint connector.
- (3) Adjust the length of 4Φ hose and install air filter on the other end.
- (4) Install another piece of the 4Φ hose from air filter to the boost pressure sensor nipple on the Sensor unit

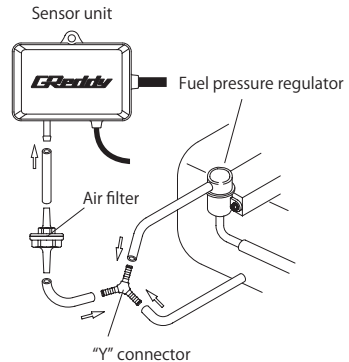

### ⚠ Warning

⚠ Please make sure that the 4mm hoses are secured with cable ties to prevent them from disconnecting.

### Important

- For Toyota's JZ engines, Mitsubishi's 4G63 engines and engines with fuel pressure controlling solenoids, make sure to tap the pressure in between intake manifold and fuel pressure control solenoid. (do not install on the line between the fuel pressure control solenoid and fuel pressure regulator.)
- Make sure to install air filter.
- Replace air filter if it is very dirty.

## Installing the solenoid valve unit – (Actuator Type)

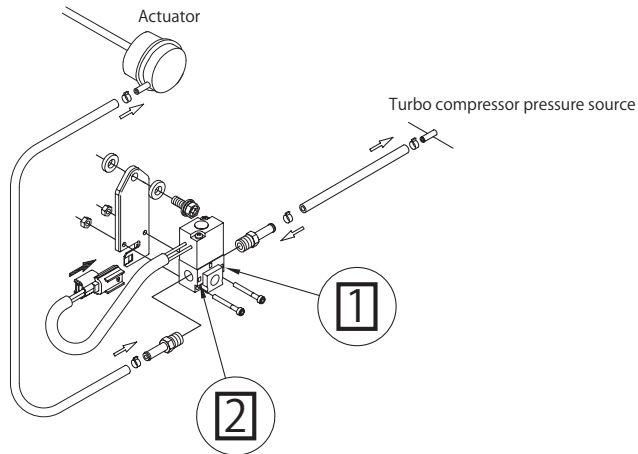

- (1) Install a 6Φ hose fitting to both the [1] & [2] ports on the solenoid valve unit.
- (2) Assemble the valve unit as shown in the picture.
- (3) Disconnect the factory hose between Actuator and turbo compressor, and connect the Turbo compressor to the [1] port of the solenoid valve unit.
- (4) Next, install the provided 6Φ hose from the Actuator to the [2] port of the solenoid valve unit. Adjust the length of the hose as needed.

\* Refer to page 14 for vehicles equipped with a factory boost pressure solenoid valve.

### Important

- Don't install the product in any place where it will be subjected to direct sunlight or high temperatures.
- Make sure to use cable ties on the hoses for secure connections.
- When installing hoses, be careful not to kink or twist the hoses.
- Audible clicking noises from valve unit may be heard from the solenoid. It is normal and is not a problem.
- Mount the valve unit with the provided anti-vibration isolators.

## Installing the solenoid valve unit – (Twin Actuator Type)

### ■ Twin Turbo Vehicles ■

Installation

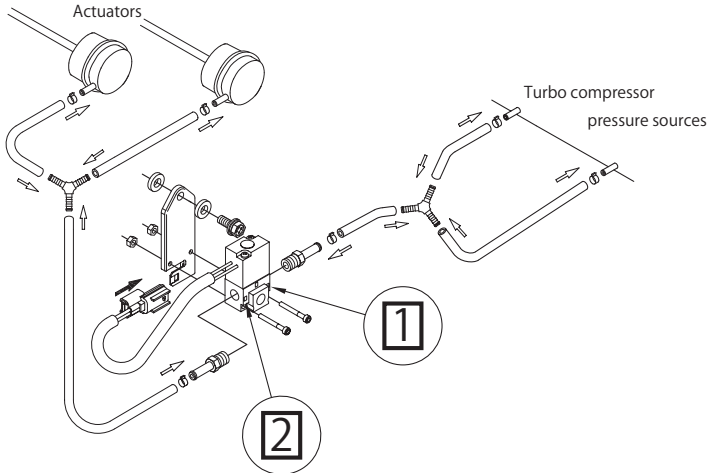

For twin turbo applications, two “Y” connectors will be required. However, the installation procedure is the same as Page 12. Place a “Y” connector to connect the [1] port of the solenoid valve to the two ports for Turbine compressor as shown in the diagram above. The same applies for the [2] port of the solenoid valve, use a “Y” connector to connect the two wastegate actuators.

## Installing the solenoid valve unit – (Actuator Type with a Factory Boost Control Solenoid Valve)

For vehicles with factory boost pressure control solenoid valves, please follow the directions below.

Before

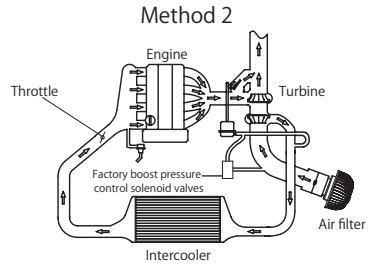
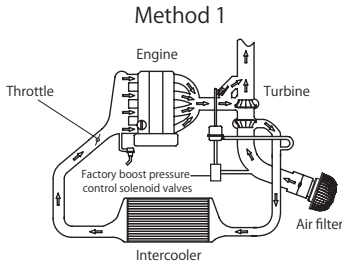

After

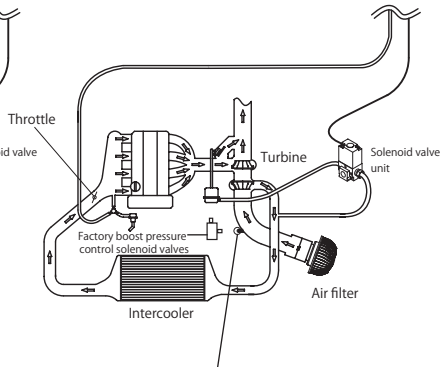
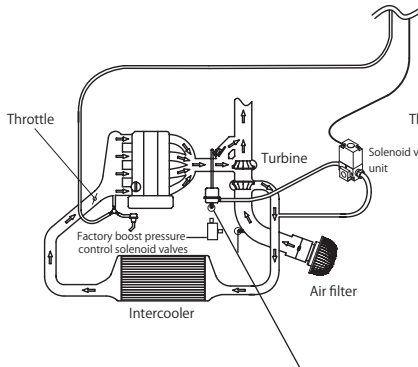

Place rubber caps on the solenoid valves where hoses were previously connected. Secure caps with cable ties to prevent them from disconnecting. (rubber caps are not provided in this kit)

## Installing the solenoid valve unit – (External Wastegate Type)

### Installation

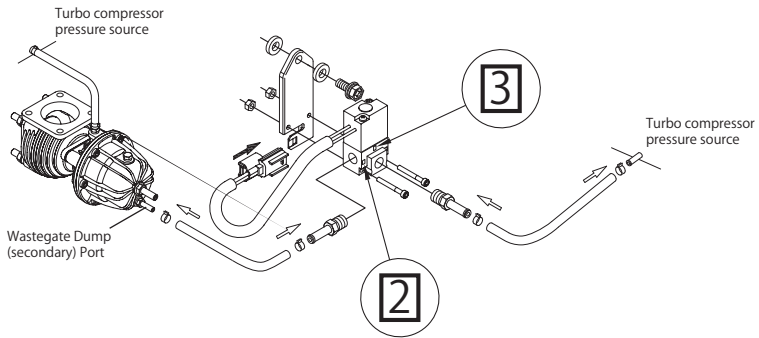

- (1) Install a 6Φ hose fitting to both the [2] & [3] ports on the solenoid valve unit.
- (2) As shown above, assemble valve unit with provided bracket and anti-vibration isolators and install in the engine bay near the wastegate.
- (3) Install the correct 6Φ hose fitting (sold separately) to wastegate dump (secondary) port (usually located on the top of the wastegate.)
- (4) Connect a 6Φ hose between newly installed 6Φ hose fitting and the [2] port on the solenoid valve. Cut and adjust the hose length as needed.
- (5) Connect another piece of 6Φ hose from the [3] port on the solenoid valve unit to a stable boost pressure source from the intake manifold or the turbocharger's compressor charge pressure pipe. (\*Be sure to have a boost pressure source connecting the main lower wastegate port to a stable boost pressure source, as well – see diagram).

\* For twin turbo applications with twin external wastegates, place a "Y" connector (sold separately) to split the connection from the [2] port of the solenoid valve unit and connect to two upper dump (secondary) ports of the wastegates.

### Important

- Don't install the product in any place where it will be subjected to direct sunlight or high temperatures.
- Make sure use cable ties on the hoses for secure connections.
- When installing hoses, be careful not to kink or twist the hoses.
- Audible clicking noises from valve unit may be heard from the solenoid. It is normal and is not a problem.
- Mount the valve unit with the provided anti-vibration isolators.



## Control Unit Installation

Once the electrical wiring is complete, find a suitable mounting location for the Control unit. You may use the provided Adjustable bracket or flush mount the unit with the provided double sided tape.

### ■ How to install ■

(1) Adjust the angle of mounting bracket to find the best position of controller. Tighten left & right bracket bolts with hex wrench.

(2) Place controller in the adjustable bracket. Attach the back of the controller into the relief in the bracket until it locks into place. The controller can be inverted, so that the dial on right side or left side.

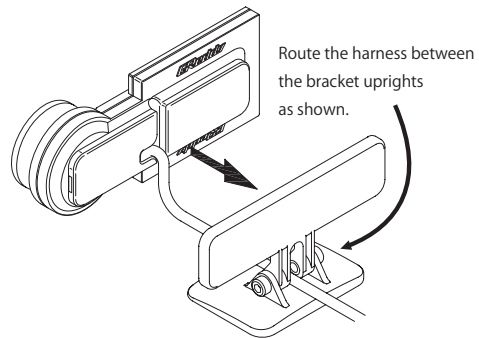
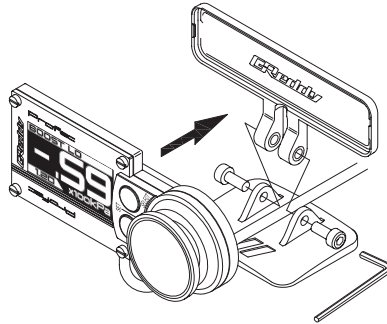

### Warning



For safety, avoid mounting the unit near air-bags.



### Caution



When using the double-sided tape, clean mounting surfaces from oil and debris with a mild detergent for best results.

### Important

- Be sure to mount the unit in a safe location that will not effect safe driving. Avoid direct sunlight and humidity.

- (1) Check for good connections between the Power harness, Valve unit and Control unit.
- (2) Reinstall factory parts as needed.
- (3) Double check all harnesses and hoses for proper installation.
- (4) Reattach the negative terminal to the battery.
- (5) Start the engine and confirm the Profec controls and display are functional.
- (6) While the engine is idling, confirm the Profec recognizes vacuum pressure.
- (7) Double check hoses for air leaks.

### Important

- Shut down the vehicle, if any problems occur.
- Refer to the Profec Test mode, to troubleshoot.
- Refer to page 18 and 39 for the Test mode and Troubleshooting the Profec.

## Basic operation

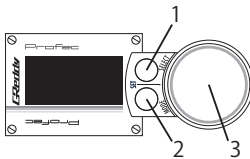

Control unit

#### 1. SELECT switch

- Push: SELECT to toggle between BOOST HI - BOOST LO.
- Push & Hold-down: SELECT to Power ON or OFF.

#### 2. MODE switch

- Push : MODE to toggle between the Real-time (boost gauge) display and a set-up screen. While in the SETUP mode screen, pushing MODE will cancel the changes made.
- Push & Hold-down: MODE to reset the recorded peak value.

#### 3. SET DIAL

- Turn : SET DIAL to change the settings and to scroll through menus. In Real-time (boost gauge) mode, it activates a shortcut to changing the SET% value.
- Push : SET DIAL to confirm program settings. In Real-time (boost gauge) mode, switch from LO or HI mode to SCRAMBLE mode.

### Important

- Please use care when operating the SET DIAL. Be careful not to use excessive force on the controls.

## Operating Instructions

Profec can switch from Real-time (boost gauge) display to other set-up screens. Please follow basic operations below, to switch between different display patterns. Refer to the page 19 and 20 for a quick reference chart.

### ■ Power ON/OFF ■

In Real-time (boost gauge) display for BOOST LO or HI mode, hold down SELECT for 2 seconds to power Off the boost controller. To power On the boost controller, follow the same procedure.

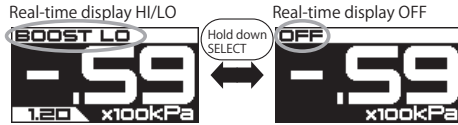

### ■ Basic setting ■

From the Real-time (boost gauge) display for OFF mode, press MODE to go to the unit' s main SET UP screen.

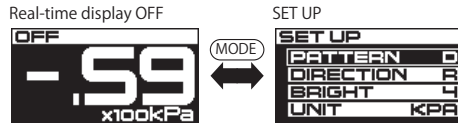

Refer to page 21.

### ■ Boost setting screen ■

From the Real-time (boost gauge) display for LO or HI mode, press MODE to go to the BOOST mode' s SET UP screen. Refer to page 29.

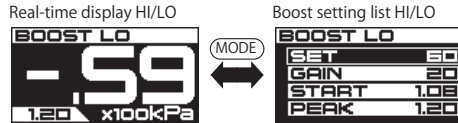

### ■ Switching HI/LO ■

From the Real-time (boost gauge) display for LO or HI mode, press SELECT to toggle between HI and LO modes.

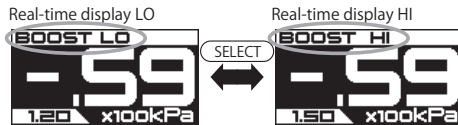

## Important

- It is important to note that when the boost controller is in the OFF mode, boost is only controlled by the wastegate spring tension. It is common for vehicles that had factory boost control solenoids removed, to have lower than factory base boost levels.
- Depending on the vehicle' s wastegate or actuator spring tension, base boost levels may vary.
- A boost controller cannot lower the boost pressure below the wastegate and actuator' s base boost level.
- Turning OFF the Profec boost controller will not turn off the unit' s backlighting or Real-time (boost gauge) display.

# Quick reference matrix

## Operations

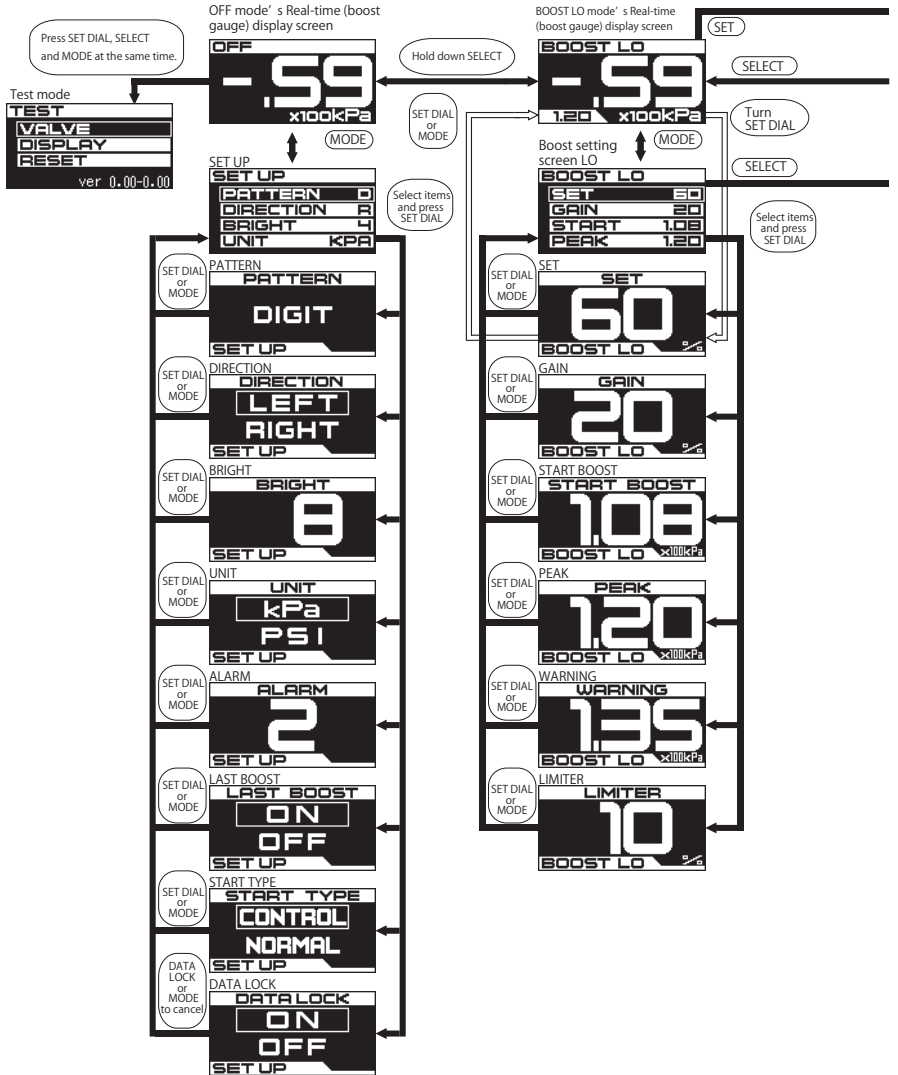

# Quick reference matrix

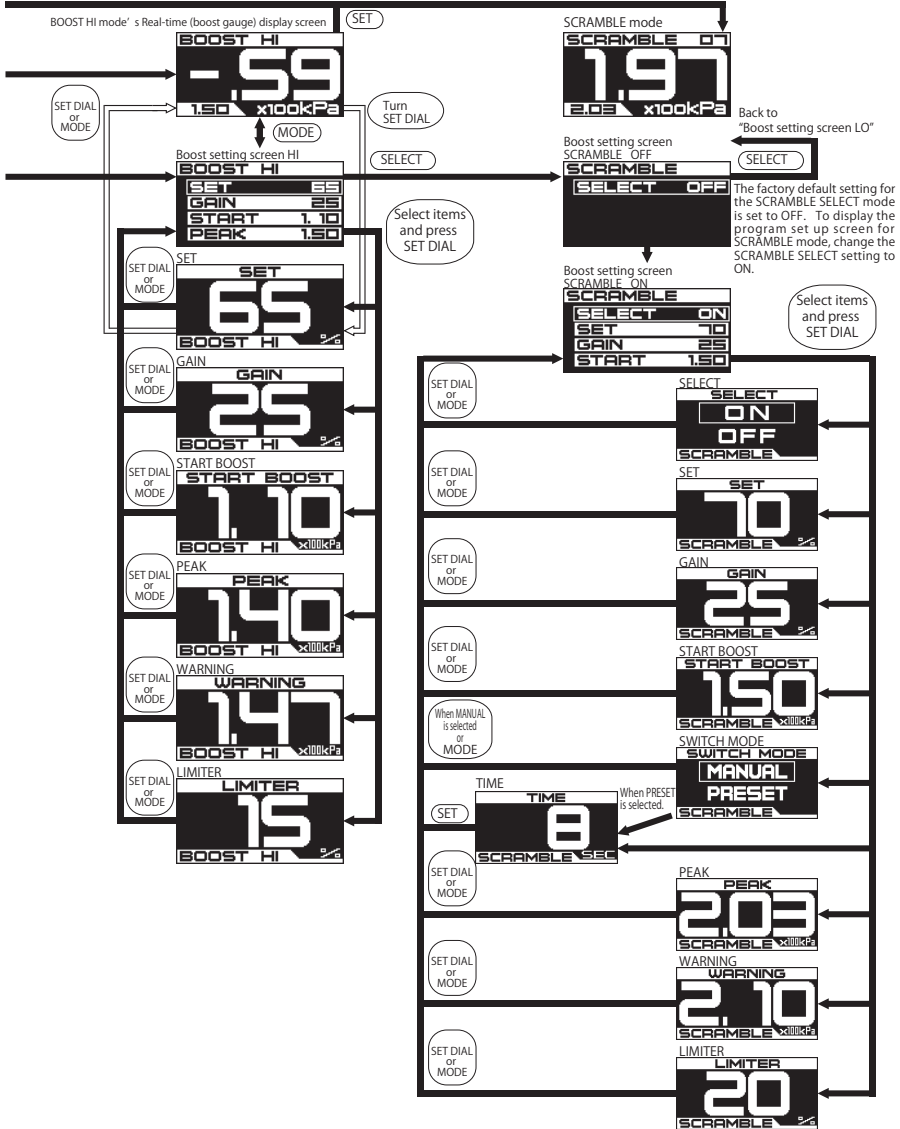

Operations

## SET UP

### Overview

You can configure settings for the displays, units, and sounds.

### ■ Programming ■

(1) When in the Real-time (boost gauge) screen for the OFF mode, press MODE to display the unit's main SET UP screen.

(2) When in the main SET UP screen, turn the SET DIAL to select an item to change.

OFF mode's Real-time (boostgauge) display screen



SET UP



**PATTERN** • • • Configures the Real-time (boost gauge) display's pattern type. - Refer to page 22.

**DIRECTION** • • • Configures the display's orientation. Refer to page 23

**BRIGHT** • • • Configures the brightness of the display and the switch's backlighting.  
- Refer to page 23

**UNIT** • • • Configures either metric or standard pressure units. - Refer to page 24.

**ALARM** • • • Configures the alarm sound patterns for the warning and limiter functions.  
- Refer to page 24

**LAST** • • • Configures if the LAST BOOST is activated. - Refer to page 25  
(Last Boost)

**ST.TYPE** • • • Configures the START BOOST program type. - Refer to page 26  
(Start Type)

**LOCK** • • • Configures the DATA LOCK and password. - Refer to page 27 – 28  
(Data Lock)

## PATTERN

Configure the Real-time (boost gauge) display settings type (for BOOST LO, HI, SCRAMBLE, and OFF modes).

### ■ Programming ■

(1) Rotate the SET DIAL to highlight PATTERN in the SETUP screen. Then press the SET DIAL to confirm.

(2) Rotate the SET DIAL to select a Real-time (boost gauge) display pattern. (DIGIT / BAR / GRAPH) Press the SET DIAL to confirm.

\* To cancel and return to the previous PATTERN setting and the main SET UP screen, press MODE

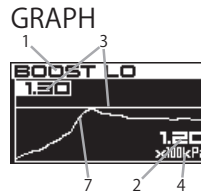
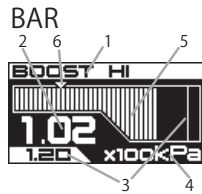
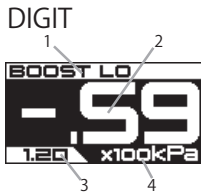
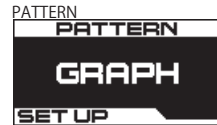
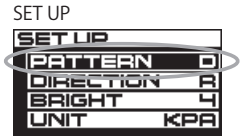

1. Boost Mode (LO, HI, or SCRAMBLE)
2. Numeric Real-time boost reading.
3. Peak value - the reading will blink for 3 seconds when the value is updated
4. Units (kPa or PSI)
5. Boost reading - The reading will display negative and positive pressures.
6. (0PSI)
7. GRAPH display - The map tracing will display the past 10 seconds (above the programmed Graph Minimum Value)

Once the GRAPH display is confirmed, the GRAPH SET UP screen will appear. Turn the SET DIAL to select the Graph Minimum Value. Then press the SET DIAL to confirm. (any boost pressure over this Graph Minimum Valve will be charted on the GRAPH display, readings under will not be shown.)

Setting ranges: 0~3.00 x 100kPa

When GRAPH is selected.



★Refer to page 38 for shortcuts.

## DIRECTION

Reverse the display direction to allow the controls to be on the other side of the screen.

### ■ Programming ■

(1) In the main SETUP screen, rotate the SET DIAL to highlight DIRECTION. Then press the SET DIAL to confirm.



(2) Rotate the SET DIAL to select the screen to be on the LEFT or RIGHT of the controls. Press the SET DIAL to confirm.



\* To cancel and return to the previous setting and the main SET UP screen, press MODE.

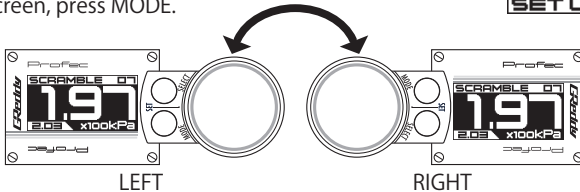

## BRIGHT

Increasing value makes the lighting brighter, and decreasing value dims the lighting.

### ■ Programming ■

(1) In the main SETUP screen, rotate the SET DIAL to highlight BRIGHT. Then press the SET DIAL to confirm.



(2) Rotate the SET DIAL to select a brightness value. Press the SET DIAL to confirm.



\* To cancel and return to the previous setting and the main SET UP screen, press MODE.



## UNIT

Configure the display boost units in either kPa or PSI.

$$100\text{kPa}=1.01972\text{kg/cm}^2=14.5\text{PSI}$$

### ■ Programming ■

(1) In the main SETUP screen, rotate the SET DIAL to highlight UNIT. Then press the SET DIAL to confirm.

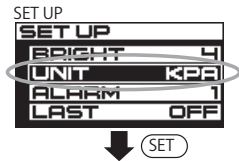

(2) Rotate the SET DIAL to highlight and select kPa or PSI. Press the SET DIAL to confirm.



\* To cancel and return to the previous setting and the main SET UP screen, press MODE.

## ALARM

Configure the alarm sounds of warning and limiter.

### ■ Programming ■

(1) In the main SETUP screen, rotate the SET DIAL to highlight ALARM. Then press the SET DIAL to confirm.

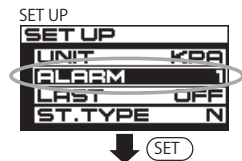

(2) Rotate the SET DIAL to highlight and select an Alarm pattern. Press the SET DIAL to confirm.



\* To cancel and return to the previous setting and the main SET UP screen, press MODE.

Alarm off : No Sound

Alarm 1: Beep Beep, Beep Beep

Alarm 2: Beep, Beep, Beep, Beep

Alarm 3: Beep-----

## LAST BOOST

Displays the highest boost reading from the last boost session, when the throttle is released. Configure the feature ON or OFF.

### ■ Programming ■

(1) In the main SET UP screen, rotate the SET DIAL to highlight LAST. Then press the SET DIAL to confirm.

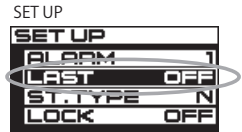

(2) Rotate the SET DIAL to highlight and select ON or OFF. Press the SET DIAL to confirm.



\* To cancel and return to the previous setting and the main SET UP screen, press MODE.

When LAST BOOST is set to ON, every time one drives (gets positive to negative pressures), the highest peak value will blink for 3 seconds on the real time display.



## START TYPE

Determines how the boost controller will function until the START BOOST value.

### ■ Programming ■

(1) In the main SET UP screen, rotate the SET DIAL to highlight ST.TYPE. Then press the SET DIAL to confirm.

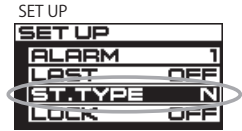

(2) Rotate the SET DIAL to highlight and select CONTROL or NORMAL. Press the SET DIAL to confirm.



\* To cancel and return to the previous setting and the main SET UP screen, press MODE.

**CONTROL** : START (BOOST) attempts to control the wastegate with the solenoid valve for the entire boost range.

**NORMAL** : START (BOOST) only activates the boost control solenoid from the programmed START (BOOST) value on.

Example:

If the START BOOST value is programmed at  $0.7 \times 100 \text{ kPa}$ , CONTROL will allow for quicker boost response.

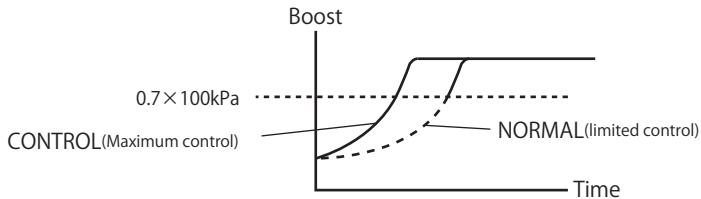

## DATA LOCK

To prevent unwanted changes or loss of data, DATA LOCK can password protect the program setting for LO / HI / SCRAMBLE / START (BOOST), but will not lock the PATTERN and ALARM from changes.

### ■ Programming ■

(1) In the main SET UP screen, rotate the SET DIAL to highlight LOCK. Then press the SET DIAL to confirm.

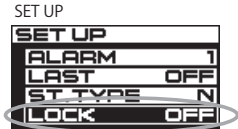

(2) Rotate the SET DIAL to highlight and select ON. Then press the SET DIAL to confirm.



(3) Once DATA LOCK is confirmed to ON, a new screen will appear and allow you to program a 3 digit password for the DATA LOCK. \* To cancel and return to the main SET UP screen, press MODE.

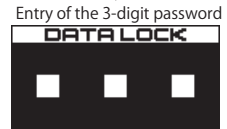

(4) Press the SET DIAL to confirm and move to the next square. Repeat and move to the third square. After the third square, press SET DIAL to return to the first square.



(5) After entering the 3 digit password, hold down SET DIAL for 3 seconds to save. Once saved, there will be a chime and the screen will return to the main SET UP screen.

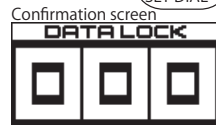

## DATA LOCK

When the DATA LOCK is ON, the lock icon will appear on the upper right corner of the screen. With DATA LOCK ON, the preset values can be displayed but cannot be changed.

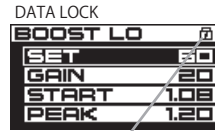

DATA LOCK ICON

### ⚠ Important

⚠ Please make note of your password. It cannot be recalled.

## ■ Programming ■

(1) In the main SET UP screen, rotate the SET DIAL to highlight LOCK. Then press the SET DIAL to confirm.

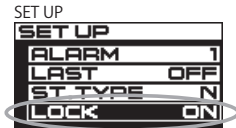

(2) Rotate the SET DIAL to highlight and select OFF. Press the SET DIAL to confirm.



(3) Input password on the DATA LOCK display using the SET DIAL.



(4) After entering the password, hold down SET DIAL for 3 seconds to confirm. Once the password is accepted, there will be chime and the screen will return to the main SET UP screen. To restore password, refer to page 39.

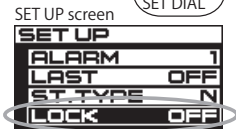

# Boost settings

## Programming Overview

Display or program the BOOST LO / BOOST HI / BOOST SCRAMBLE mode settings. Refer to page 36~37 regarding SCRAMBLE mode.

### ■ Programming ■

(1) In Real-time (boost gauge) display for BOOST LO or HI mode, press MODE to display that mode's set up screen.

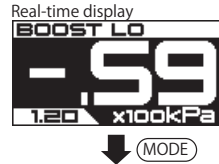

(2) Turn the SET DIAL to highlight the item you wish to change. Press the SET DIAL to confirm.

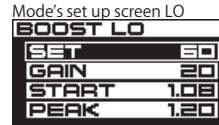

- SET . . . . . SET --- Program a SET % value. Refer to p30.
- GAIN . . . . . GAIN --- Program a GAIN % value. Refer to p31.
- START . . . . . START --- Program a START BOOST pressure value. Refer to p32.  
(START BOOST)
- PEAK . . . . . PEAK --- Recall & Reset the recorded PEAK boost pressure value. Refer to p33.
- WARNING . . . . . WARNING --- Program a WARNING boost pressure value. Refer to p34.
- LIMITER . . . . . LIMITER --- Program a LIMITER % value. Refer to p35.

Boost settings

### ■ How to change to another BOOST LO/HI/SCRAMBLE mode's set up screen ■

In a BOOST mode's set up screen, press SELECT to toggle to the next BOOST mode set up screen. BOOST LO / BOOST HI / BOOST SCRAMBLE mode set up.

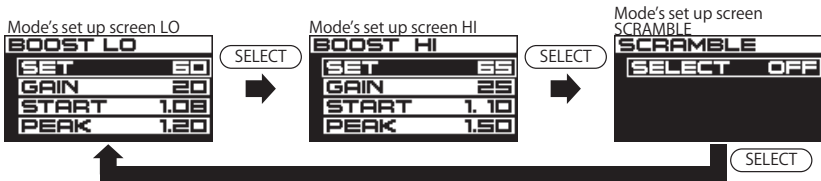

# SET

Changes the boost pressure by controlling the boost control solenoid valve.

This SET value in percentage (%) adjusts the boost control solenoid valve duty cycle, it does not set an actual boost pressure value.

- As the SET % value is increased between 0-100%, it increases the boost level over the turbocharger's base wastegate boost level.
- 100% value will increase the boost level of the turbocharger systems maximum capacity.
- 0% value will be the base boost level turbocharger system (boost can not be set below the base boost level).

## ■ Programming the Boost Pressure ■

(1) In a BOOST mode set up screen, highlight SET and press the SET DIAL to confirm.

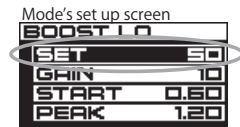

(2) Rotate the SET DIAL to change a SET % value.

To cancel and return to the previous setting and the BOOST mode set-up screen, press MODE.



(3) To program the SET % value, press the SET DIAL to confirm and return to the BOOST mode set up screen.

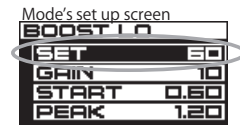

Boost settings

\* Refer to page 38 for SET shortcuts.

### Important

- There may be vehicles or turbocharger set-ups which are unable to reach your target boost pressure.

## GAIN

Controls the boost curve tendency after the START pressure value. (stability and consistency at higher RPMs)

- Program a boost level with the SET and START, before adjusting the GAIN.
- If the START pressure value is set to 0x100kPa or 0PSI, GAIN will not function.

### ■ Programming the Boost Stability ■

(1) In a BOOST mode set up screen, highlight GAIN and press the SET DIAL to confirm.

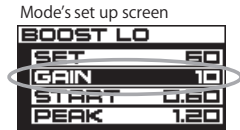

(2) Rotate the SET DIAL to change a GAIN % value.

\* To cancel and return to the previous setting and the BOOST mode set-up screen, press MODE.



(3) To program the GAIN % value, press the SET DIAL to confirm and return to the BOOST mode set up screen.

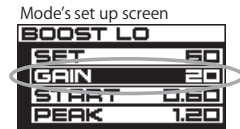

To improve boost from dropping at higher RPM (boost fall off), adjust the GAIN to a positive value. There may be vehicles or turbocharger configurations which will not allow for improvements.

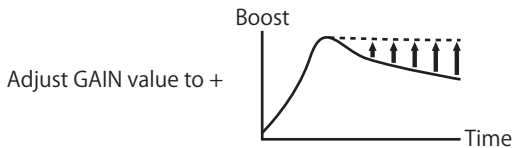

Once the SET and START pressure values are adjusted to obtain the desired boost pressure, the GAIN can also be used to drop boost pressure at higher RPMs by setting a negative value for the GAIN.

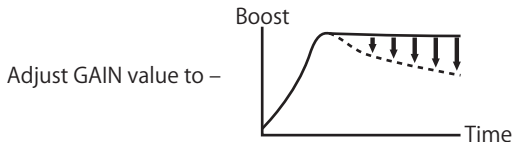

If the GAIN value is programmed too high, it may cause unstable boost, with a fluctuating boost curve (boost creep).



## START BOOST

Affects the initial boost response. This may vary depending on the ST.TYPE style selected. Refer to page 26.

**CONTROL:** Maximizes the boost response to the targeted boost pressure.

Boost will rise faster by selecting a START value closer to the targeted boost pressure. (however too hi of a setting can initiate boost spike)

**NORMAL:** In this configuration the boost controller will not improve boost response, but will start controlling the wastegate through the boost solenoid from this boost pressure value on. (this setting maybe ideal for already quick spooling turbocharger systems)

### ■ Programming the Boost Response ■

(1) In a BOOST mode set up screen, highlight START and press the SET DIAL to confirm.

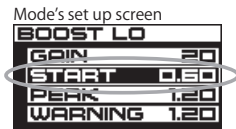

(2) Rotate the SET DIAL to change the START pressure value activation point.

\* To cancel and return to the previous setting and the BOOST mode set-up screen, press MODE.



(3) To program the START value, press the SET DIAL to confirm (this action will bring you back to the BOOST mode set-up screen).

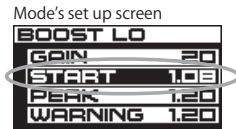

If ST. TYPE is set to CONTROL, Boost Spike may occur when the START pressure value is programmed too high. Boost Spike --- is a phenomenon that unintentionally causes the boost pressure to overshoot the targeted boost pressure before it stabilizes.

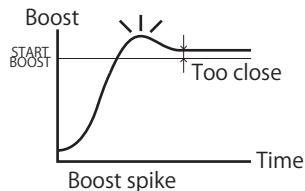

## PEAK

Displays the peak boost value in memory (Only positive pressure).

The peak value won't be deleted until it is reset.

### ■ Programming and Resetting PEAK ■

(1) In a BOOST mode set-up screen, highlight PEAK and press the SET DIAL to confirm.

(2) The Peak boost pressure value since the last reset will be recorded.

Press and hold down the SET DIAL for over 1sec, to reset the Peak value. A chime will sound and reset the Peak display.

\* To cancel and return to the previous setting and the BOOST mode set-up screen, press MODE.

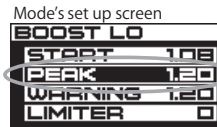
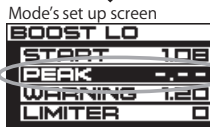
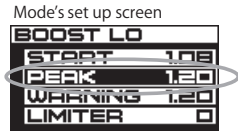

\* Refer to Page 38 for RESET shortcuts.

## WARNING

An audible and visual alarm will activate if the boost pressure exceeds this value.  
Program the maximum acceptable boost level.

### ■ Programming the WARNING boost pressure value ■

(1) In a BOOST mode set-up screen, highlight WARNING and press the SET DIAL to confirm.

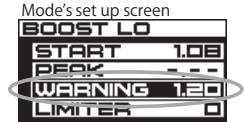

(2) Rotate the SET DIAL to change the WARNING alarm point. \* To cancel and return to the previous setting and the BOOST mode set-up screen, press MODE.



(3) To program the WARNING boost value, press the SET DIAL to confirm and return to the BOOST mode set-up screen.

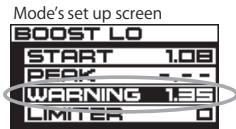

### ■ While WARNING Alert is activated ■

Once the boost exceeds the programmed WARNING boost value, the display will show a WARNING Alert with an audible Alarm.



## LIMITER

A safety function to lower the boost, once the WARNING boost value is exceeded.

The percentage boost lowered can be programmed.

If the LIMITER is programmed to 0%, the unit will not reduce boost.

### ■ Programming the Boost Limiter ■

(1) In a BOOST mode set-up screen, highlight LIMITER and press the SET DIAL to confirm.

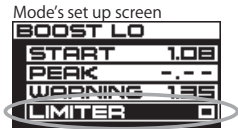

(2) Rotate the SET DIAL to change a LIMITER % to reduce the boost.



(3) To program the LIMITER %, press the SET DIAL to confirm and return to the BOOST mode set-up screen.

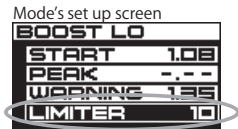

Once the LIMITER is activated at the WARNING boost value, it will continue to reduce boost by the programmed percentage until the boost pressure falls to negative pressure (vacuum).

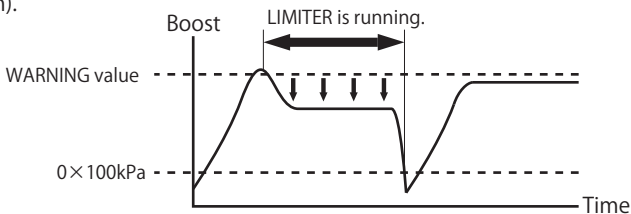

### ■ While LIMITER is activated ■

Once the LIMITER is activated and the boost controller will attempt to reduce boost by the programmed percentage.

While being activated, the display screen will show a LIMITER warning alert.



## SCRAMBLE

SCRAMBLE is an ENHANCED BOOST feature that can be activated by pressing the SET DIAL. SCRAMBLE can be momentarily or adjusted to a preset length of time that can be activated from the Real-time BOOST LO or BOOST HI mode.

### ■ Programming the SCRAMBLE feature ■

(1) In the BOOST HI set-up screen, press the MODE button, then press the SELECT button. This will bring you to the SCRAMBLE set-up screen. Turn the SET DIAL to SELECT (on the screen) to choose to turn ON or OFF the SCRAMBLE feature. Refer to page 29. The factory default is set to OFF.

(2) Turn the SET DIAL to ON and then press the SET DIAL to confirm. \* To cancel and return to the previous setting and the BOOST HI mode set-up screen, press MODE.

(3) When SCRAMBLE SELECT (on the screen) is ON, this allows you to view and change the SCRAMBLE set-up screen.

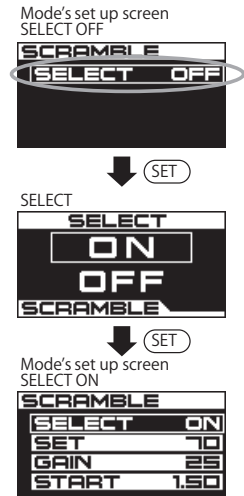

The following items can be programmed from the SCRAMBLE set-up screen.

There is only one SCRAMBLE feature for both BOOST LO & BOOST HI mode.

- SELECT . . . . Turns ON / OFF the SCRAMBLE boost mode.
- SET . . . . . Program a SET % value. Refer to page 30.
- GAIN . . . . . Program a GAIN % value. Refer to page 31.
- START . . . . . Program a START BOOST pressure value. Refer to page 32.
- (START BOOST)
- SW. MODE . . . . . Configures how the SCRAMBLE mode is activated. Refer to page 37.
- (SWITCH MODE)
- TIME . . . . . Program the duration of time the SCRAMBLE mode is in use once activated. Refer to page 37.
- PEAK . . . . . Recall & Reset the highest recorded PEAK boost value.
- WARNING . . . . . Program a boost value when the WARNING alarm is activated. Refer to page 34.
- LIMITER . . . . . Program a LIMITER % to reduce boost once over the WARNING value. Refer to page 35.

## SWITCH MODE

Configure the transition to SCRAMBLE feature.

### ■ Programming the SCRAMBLE boost feature activation ■

(1) In the SCRAMBLE feature set-up screen, highlight SW.MODE and press the SET DIAL to confirm.

Mode's set up screen



(2) Use the SET DIAL to choose & confirm between MANUAL or PRESET. \* To cancel and return to the previous setting and the SCRAMBLE mode set-up screen, press MODE.

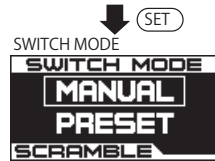

MANUAL: SCRAMBLE feature is activated as long as the SET DIAL is pushed and held down, while in a BOOST LO / HI Real-time (boost gauge) mode.

PRESET: SCRAMBLE feature is activated for a timed duration once the SET DIAL is pressed, while in a BOOST LO / HI Real-time (boost gauge) mode.

\*\* Once PRESET is selected for the SWITCH MODE, you can program how long of a TIME the SCRAMBLE feature will be activated for. The setting ranges from 1-99sec.

TIME(When PRESET is selected)



\*\* The TIME SET-UP screen will appear when PRESET is confirmed.

### ■ About the SCRAMBLE feature display ■

With the SCRAMBLE feature SELECT set to ON, you can activate the SCRAMBLE feature from the BOOST LO or BOOST HI mode's Real-time (boost gauge) display screens, by pressing the SET DIAL. When the SWITCH MODE is set to PRESET, a countdown will display in the upper right corner of the screen, when the SCRAMBLE feature is activated. At anytime during it's countdown, you can press the SET DIAL again to end the timed SCRAMBLE feature early and the unit will then return to the previous BOOST LO or BOOST HI mode.

Real-time display



SCRAMBLE mode (PRESET)



Remaining time

## Shortcut commands

Shortcut commands allow the user to more easily access specific controls.

### ★PATTERN Shortcut

While a Real-time (boost gauge) display (OFF / LO / HI), press SELECT and MODE at the same time to change the PATTERN (DIGIT / BAR / GRAPH).

Refer to page 22 about PATTERN.

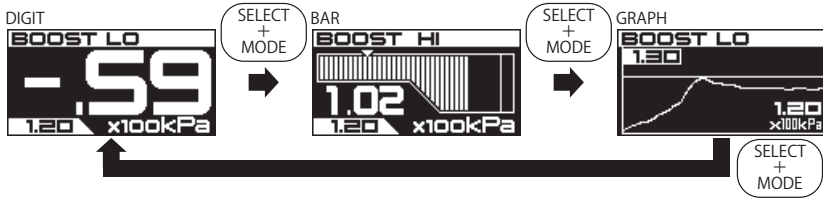

### ★SET (%) Shortcut

While in a Real-time (boost gauge) display (LO / HI), if you turn the SET DIAL, the BOOST (LO / HI) mode' s SET % set-up screen will display and allow you to change the SET % value. Press the SET DIAL to confirm this new value or to cancel and return to the previous setting, press MODE. Refer to page 30.

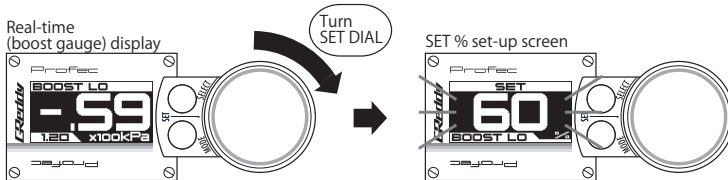

### ★PEAK Reset Shortcut

While in a Real-time (boost gauge) display (LO / HI), press and hold down MODE till the unit chimes, to reset the displayed PEAK value.

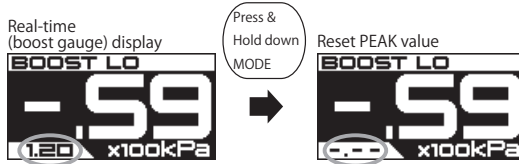

## Troubleshooting

When the boost doesn't increase or there is something wrong, please refer to the following: Test mode – (below), Boost Setting Tips / Guidelines – page 40 and Factory Default Settings / Guidelines – page 41.

### Test mode

Checks: VALVE operation, DISPLAY test, unit RESET and Software Version.

#### ■ Operation procedure ■

(1) While in the OFF mode's Real-time (boost gauge) display, press SELECT, MODE and SET DIAL at the same time to initiate the TEST mode.

(2) In the TEST mode screen, use the SET DIAL to select and confirm an item to be tested. (VALVE / DISPLAY / RESET)

#### ■ VALVE ■

Manual test the Boost Control Solenoid Valve.

Test if the valve unit is operating. Turn the SET DIAL to manual operate the Boost Control Solenoid Valve from 0-100%. \*To cancel and return to the TEST mode screen, press MODE.

#### ■ DISPLAY ■

Test the OLED screen for dead pixels. Turn SET DIAL to light up or turn off the OLEDs. \*To cancel and return to the TEST mode screen, press MODE.

#### ■ RESET ■

Use the SET DIAL to select & confirm YES to reset all programs to the factory default settings. If the LOCK is set to ON and the password is forgotten, you will have to RESET the unit to access all the settings. If you do know your password and still want to RESET the unit, please note your password before the RESET.

OFF Real-time  
(boost gauge) display



Press SET, and SELECT  
and MODE  
at the same time.

Test mode



Current software version

VALVE



RESET





## Boost Setting Tips

(1) Slowly increase the SET % value and monitor the new boost pressure until you reach your targeted boost pressure.

Tip! Program the LAST BOOST to ON, so you can check the most recent high boost pressure achieved.

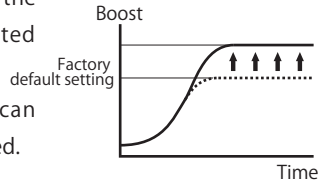

(2) Once the ideal SET % value is confirmed to your ideal target boost pressure, program the START value below your target boost pressure to improve boost response.

When the START TYPE is programmed to CONTROL, the solenoid valve controls the wastegate for the full range, providing the most control and fastest response.

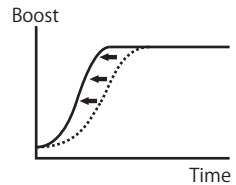

\*\* However if the START value is too close to your target boost pressure, it may have a tendency to boost-spike. Please be aware that an aggressive START value can cause dangerous boost-spikes.

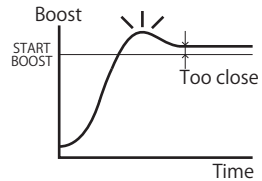

(3) Once that is complete, you can program the GAIN % value to improve boost stability, in cases when boost drop as RPMs increase. (There may be vehicles or turbocharger configurations which will not allow for improvements.)

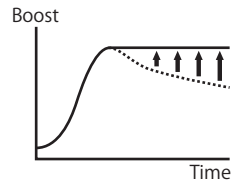

## Factory Default Settings

Main SET UP list		BOOST LO mode	
PATTERN . . . . .	DIGIT	SET . . . . .	0 (%)
DIRECTION . . . . .	LEFT	GAIN . . . . .	0 (%)
BRIGHT . . . . .	10	START BOOST . . . . .	0 (× 100kPa)
UNIT . . . . .	kPa	PEAK . . . . .	0 (× 100kPa)
ALARM . . . . .	1	WARNING . . . . .	1.20 (× 100kPa)
LAST BOOST . . . . .	ON	LIMITER . . . . .	0 (%)
START TYPE . . . . .	CONTROL	SCRAMBLE . . . . .	OFF
DATE LOCK . . . . .	OFF		

## Trouble Shooting

This section provides troubleshooting guidelines if problems still occur after performing the TEST mode on page 39.

Symptom	Cause	Solution
1. Boost pressure does not increase or Boost pressure continues to increase.	* Boost pressure signal is not recognized.	* Check vacuum hose routing.
	* Disconnected solenoid valve harness. * Bad wiring connection.	* Check for any damage to the solenoid valve unit or wiring.
	* Incorrect installation: Valve unit, Hose fittings, Hoses and/or Pressure source. * Turbo piping leak.	* Use Hose-fittings as follows: Actuator type use port [1]. External type use port [3] * Check that the Solenoid valve and fitting are installed properly.
2. Boost response is slow.	* START TYPE is set to NORMAL.	* Program CONTROL for START TYPE.
	* START BOOST is set to 0.	* Increase the START BOOST value.
3. Boost Spikes (Overshooting)	* START BOOST value is set too high.	* Decrease the START BOOST value.
4. Boost pressure drops / Boost rises with RPM (Boost Creep)	* Incorrect GAIN % value programmed.	* Adjust GAIN % value.
	* Lack of turbo capacity. * Insufficient Actuator or Wastegate. * Excessive exhaust back-pressure.	* Upgrade Actuator, External Wastegate and/or Turbo.