

PROFEC A / PROFEC B / T.V.V.C.

Also available are Application Specific Diagrams for:

1993-97 Supra (JZA80)

1993-96 RX-7 (FD3S)

1990-98 3000GT (Z16A)

Standard Actuator Wastegate Installation

- (1) Intake Manifold
- (2) Pressure Source
- (3) Actuator / Top External

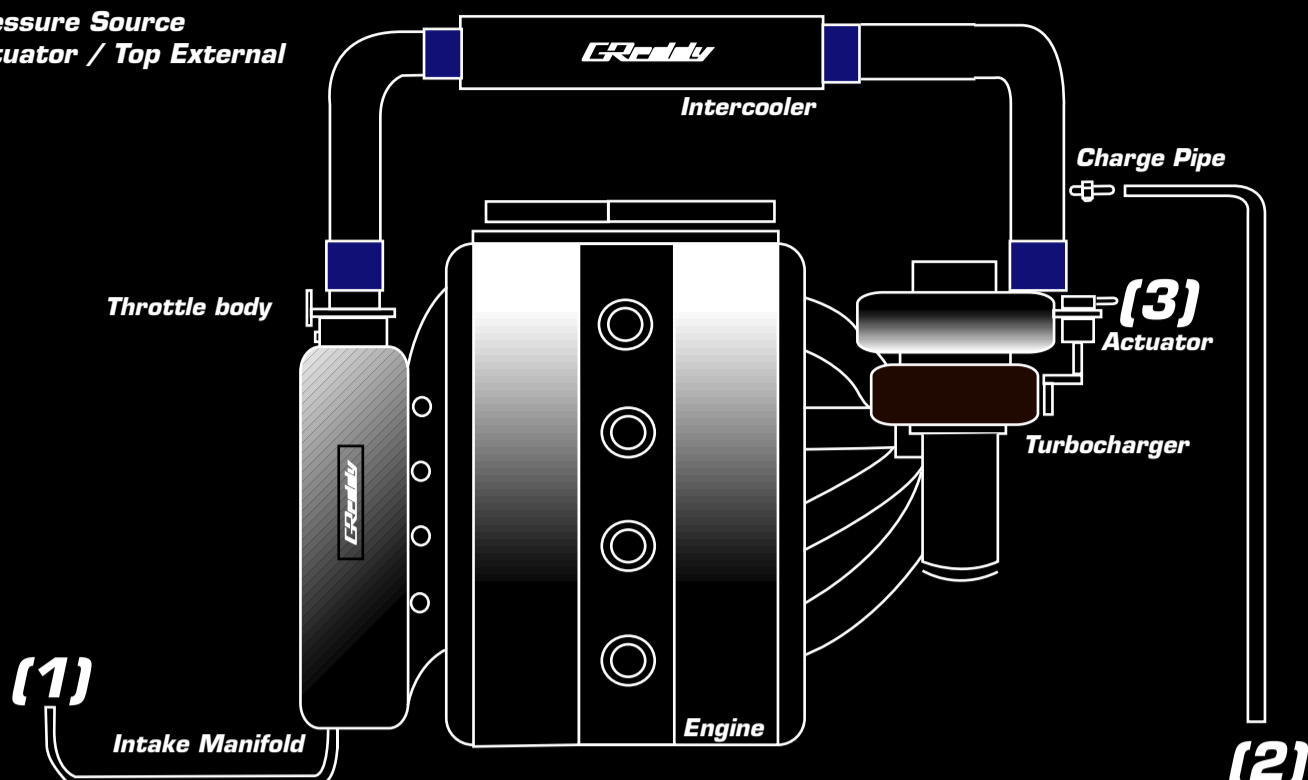

Port	TVVC	A-spec	B-spec
(1)	Not Used	A	Head unit
(2)	IN	B	IN
(3)	OUT	C	OUT

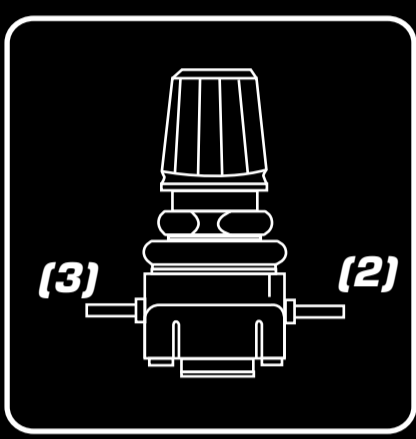

T.V.V.C. MINI

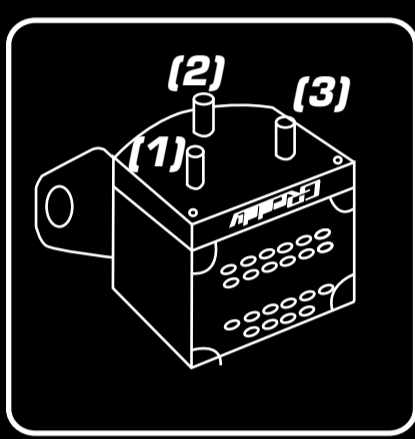

PProfec A-spec

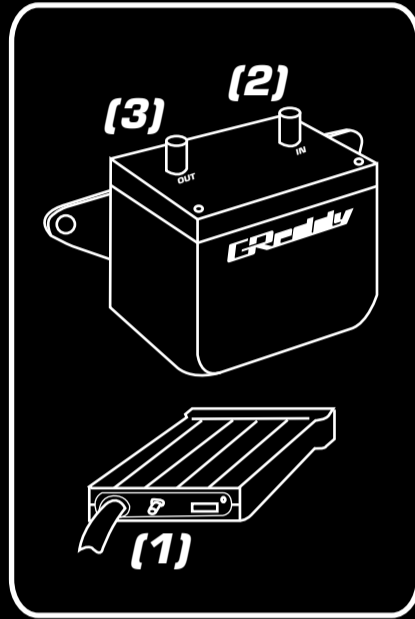

PProfec B-spec

Standard External Wastegate Installation

- (1) Intake Manifold
- (2) Pressure Source
- (3) Actuator / Top External

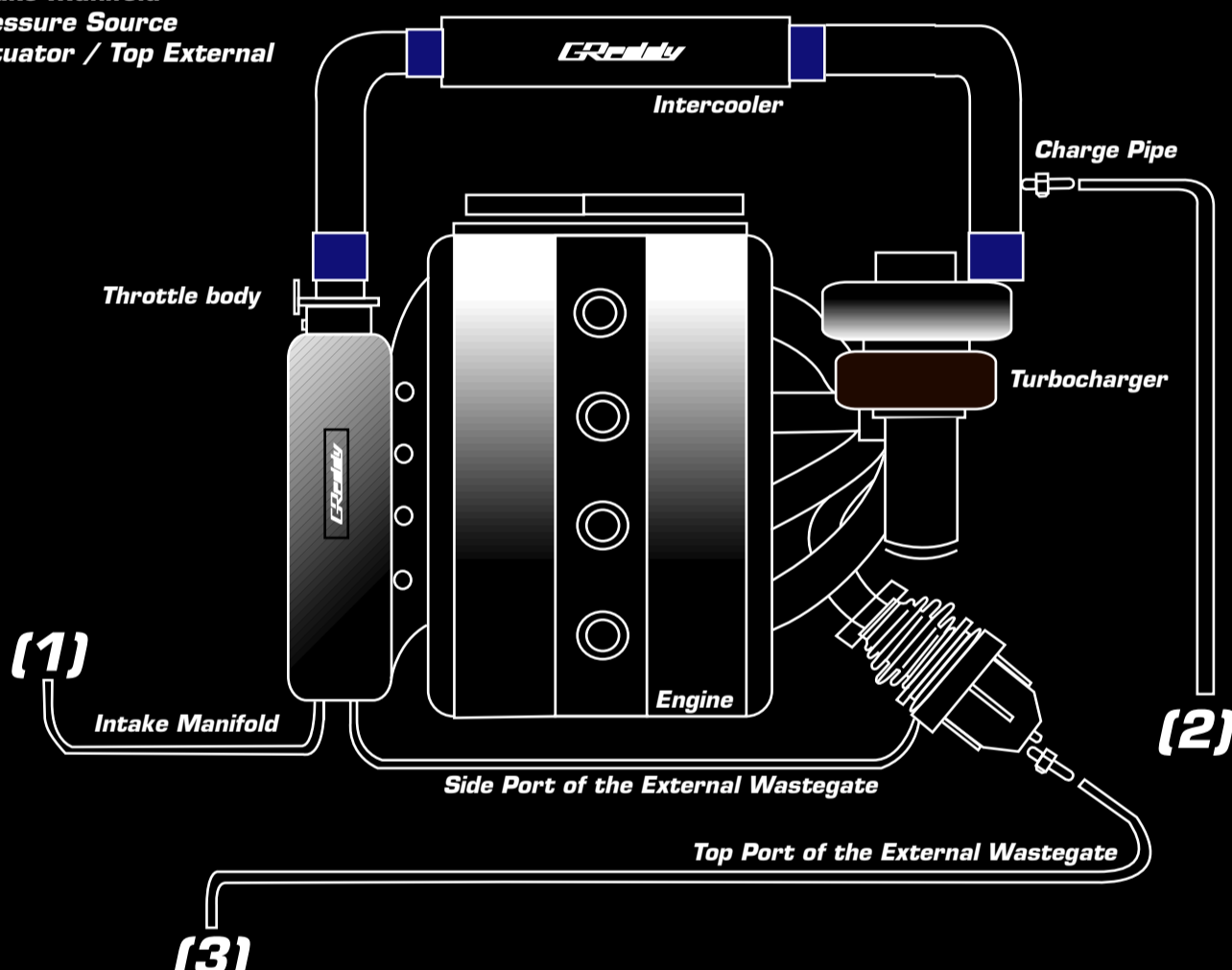

PProfec Dip Switch Settings

A Spec. Settings

<p>ACTUATOR TYPE</p>	<p>EXTERNAL TYPE</p>
<p>OFFSET: -100~+100%</p>	<p>OFFSET: -50~+50%</p>
<p>WHEN OVER BOOSTING OCCURS</p>	<p>NORMAL</p>
<p>WHEN BOOST FALLS OFF</p>	<p>NORMAL</p>

B Spec. Settings

<p>ACTUATOR TYPE</p>
<p>ACTUATOR TYPE (WHEN OVER BOOST OCCURS)</p>
<p>EXTERNAL TYPE</p>
<p>EXTERNAL TYPE (WHEN OVER BOOST OCCURS)</p>

- These tips should not be used to replace the normal instruction manual. Always read and understand the instruction manual fully, before attempting any installation.
- Always use the provided filters on the suggested hose. (See Boost Controller Instruction)
- Secure all line with wire ties or hose clamps
- Make sure the dip switches on the back of the head unit is on the correct setting.