

**NOT FOR USE ON AIRBAG EQUIPPED VEHICLES**

**CLASSIC/CHALLENGER WHEELS ONLY**

IF YOU HAVE A PAINTED SPOKE, YOUR WHEEL CAME WITH A SILVER FOIL DISC THAT MUST BE USED FOR PROPER HORN OPERATION. REFER TO INSTRUCTION SHEET WITH WHEEL.

**DO NOT THROW AWAY!**

SHOWN: TYPICAL CLASSIC/CHALLENGER INSTALLATION  
SEE INSTRUCTION SHEET PROVIDED WITH WHEEL FOR SIGNATURE SERIES HORN HOOKUP.

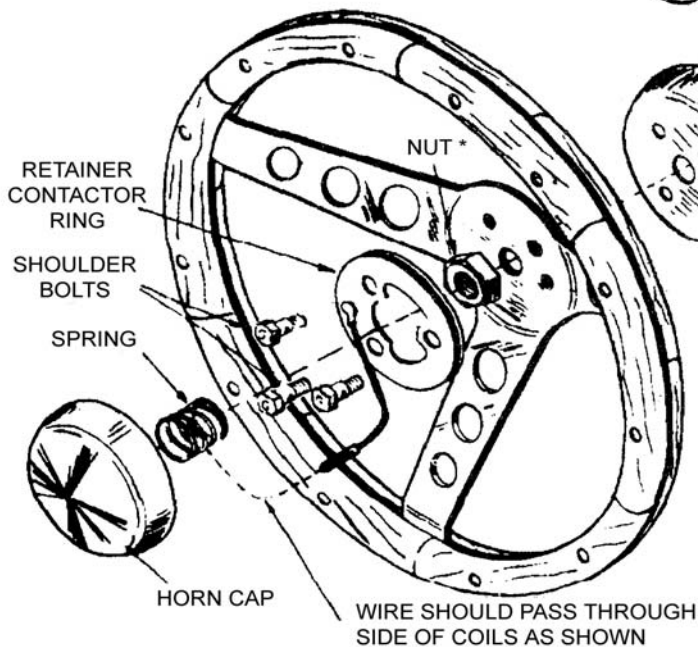

# GRANT

# FORM #2

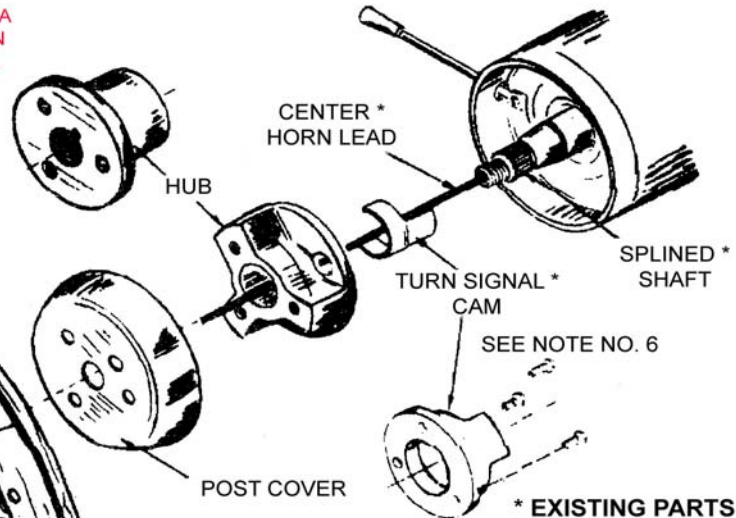

1. Point wheels straight ahead and disconnect battery or pull horn fuse before starting removal of the old wheel so horn won't short out and blow during installation.
2. Remove horn mechanism. This is normally done by one or more of the following steps:
  - a.) Press down on horn cap or ring and turn.
  - b.) Remove emblem cap from its snapped-in condition by grasping it and pulling toward you or pry loose.
  - c.) Horn ring and emblem may be secured by screws, which are concealed in rear side of wheel spokes.

If one of the above operations has not removed all of the horn parts, it will have exposed the remaining screws to permit easy removal of the balance of such parts.

3. Remove nut holding wheel to shaft.
4. Mark shaft as to which is the top of the wheel.
5. With conventional puller, (or GRANT puller 5891), use the two tapped holes which you will find in the hub of old wheel to pull off the steering shaft.

If a puller is not available, you may improvise an efficient one to do the job. By drilling two holes of the proper size in a short steel bar and using two screws of the proper length, you can tighten them and pull the old wheel very easily.

6. If custom hub does not have provisions for turn signal cancellation, remove the turn indicator cam from the back of your old steering wheel and reinstall it in the same position on back of hub. Generally this part is affixed to the steering wheel with screws, or clamped on by spring tension. **If your kit has a roll pin, simply insert it into the hole on the bottom of custom hub.**

7. Position custom hub on splined shaft, observing that "top" is located in accordance with the mark you made in step No. 4. The horn lead must pass through the center of the hub.
8. Position post cover (unless kit has a black hub, in which case a post cover is not provided) and wheel on hub, using the three shoulder bolts provided, but do not tighten.
9. Check to see if wheel is in the proper position, and if correct, install the wheel retainer nut and tighten securely.

Remove shoulder bolts and reinstall the same through retainer contactor ring so that the **fiber side is toward you.**

When tightening the shoulder bolts, please keep in mind that excessive torque will result in damage to the hub. The wheel retainer nut, if properly tightened, will firmly hold hub/wheel assembly to vehicle.

10. Using the supplied crimp connector attach wire provided to vehicle's center wire with pair of pliers. Attach other end to the terminal on retainer contactor ring. Don't forget wire must pass through coils of spring as shown in diagram.
11. With spring in position on top of nut, place horn cap in position by aligning dimples in cap with reliefs in fiber material and push until dimples pass fiber. Turn cap left or right until tight (about 1/4"-1/2").
12. Reconnect battery or replace fuse and enjoy your new wheel.

### TORQUE REQUIREMENTS

SHOULDER BOLTS 10-12 FT/LBS  
STEERING SHAFT NUT 25-30 FT/LBS