

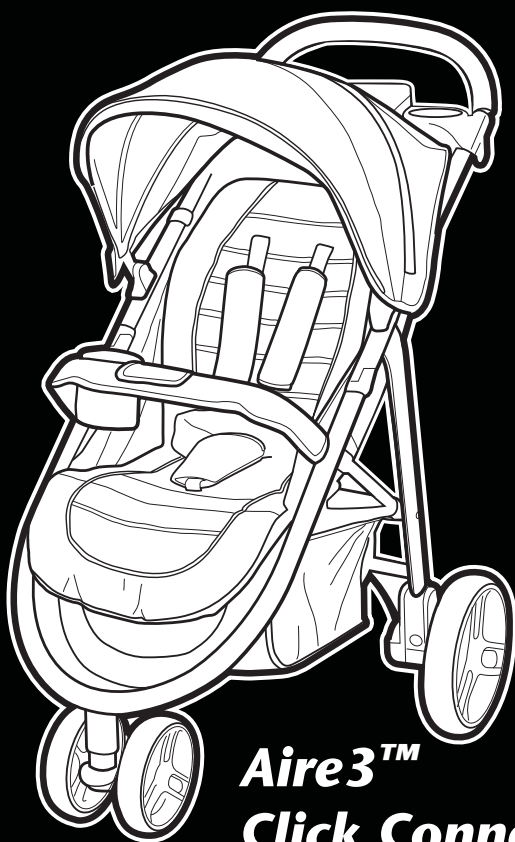

Lightweight Stroller



Aire3™
Click Connect™

Owner's Manual

WARNING

Failure to follow these warnings and the assembly instructions could result in serious injury or death.

- **PLEASE SAVE OWNER'S MANUAL FOR FUTURE USE.**
- **ADULT ASSEMBLY REQUIRED.**
- **NEVER LEAVE** child unattended. Always keep child in view while in stroller.
- **AVOID SERIOUS INJURY** from falling or sliding out. Always use seat belt. After fastening buckles, adjust belts to get a snug fit around your child.
- **CHILD MAY SLIP INTO LEG OPENINGS AND STRANGLE.** Never use seat in a reclined carriage position unless pop-up enclosure is raised to cover the front opening. (See pages 21-22 Enclosure)
- **AVOID FINGER ENTRAPMENT:** Use care when folding and unfolding the stroller. Be certain the stroller is fully erected and latched before allowing your child near the stroller.
- **AVOID STRANGULATION.** DO NOT place items with a string around your child's neck, suspend strings from this product, or attach strings to toys.
- **NEVER USE STROLLER ON STAIRS** or escalators. You may suddenly lose control of the stroller or your child may fall out. Also, use extra care when going up or down a step or curb.
- **STROLLER TO BE USED** only at walking speed. Product not intended for use while jogging, skating, etc.
- **USE OF THE STROLLER** with a child weighing more than 50 lbs (22.7 kg) or taller than 45 in. (114.3 cm) will cause excessive wear and stress on the stroller. Use the stroller with only one child at a time.
- **TO PREVENT TIPPING,** do not place more than 3 lbs (1.4 kg) on the parent's tray.
- **TO AVOID BURNS,** never put hot liquids in the parent's tray.
- **TO PREVENT A HAZARDOUS, UNSTABLE CONDITION,** never place purses, shopping bags, parcels or accessory items on the handle or canopy.
- **TO PREVENT A HAZARDOUS, UNSTABLE CONDITION,** do not place more than 10 lbs (4.5 kg) in the storage basket.
- **DO NOT** use storage basket as a child carrier.
- **NEVER PLACE** child in the stroller with head toward front of stroller.
- **NEVER ALLOW YOUR STROLLER** to be used as a toy.
- **DISCONTINUE USING YOUR STROLLER** should it become damaged or broken.
- **PRODUCT NOT INTENDED** for use with roller skates or in-line skates.

WARNING

USING GRACO® INFANT CAR SEAT WITH STROLLER:

- **USE ONLY A GRACO® SNUGRIDE® CLICK CONNECT™ CAR SEAT** with this travel system. (Not intended for use with SnugRide®, SnugRide® 30, SnugRide® 32, SnugRide® 35, Infant Safeseat™, AUTOBABY, LOGICO S, JUNIORBABY and ASSURA infant car seats.) Improper use of this stroller with other manufacturers' car seats may result in serious injury or death.
- **READ THE MANUAL** provided with your Graco car seat before using it with your stroller.
- **ALWAYS SECURE** your child with the car seat harness when using the car seat in the stroller. If your child is already in the car seat, check that the child is secured with the harness.



Parts list

Check that you have all the parts for this model **BEFORE** assembling your product. If any parts are missing, call Customer Service.

No tools required.

All models

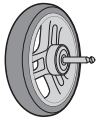

2X

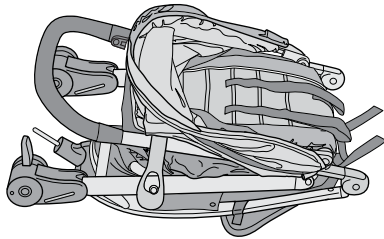
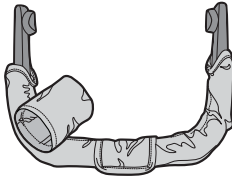
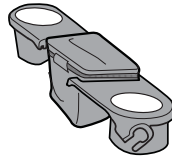
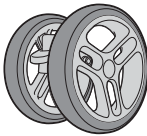

On certain models



To Open Stroller

Before assembly be sure to place stroller on top of a piece of cardboard or other protective cover to prevent damage to floor surface.

1

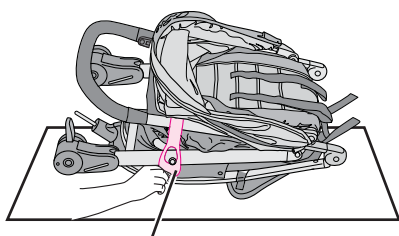

Storage latch

2

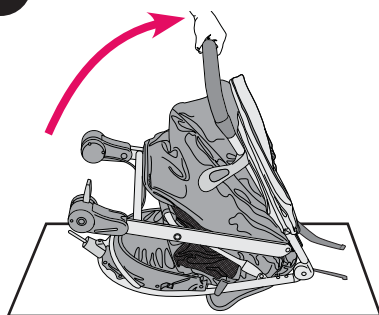

3

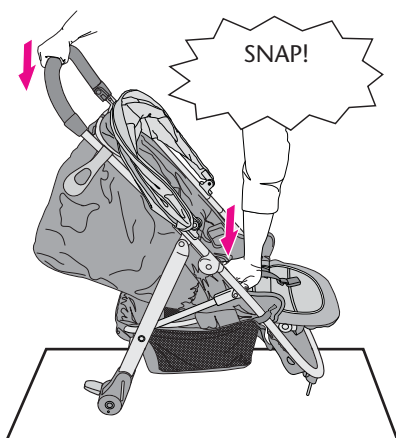

CHECK that the stroller is completely latched open every time you open the stroller and before continuing with the rest of the assembly steps. Push down on stroller to be sure seat is locked.

Canopy

1

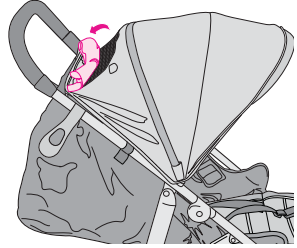
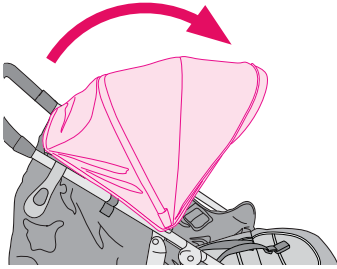

2

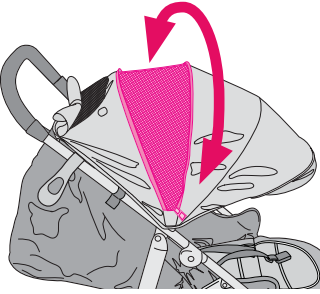

3

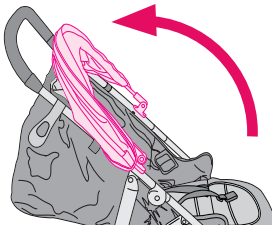

To adjust.

Front Wheel

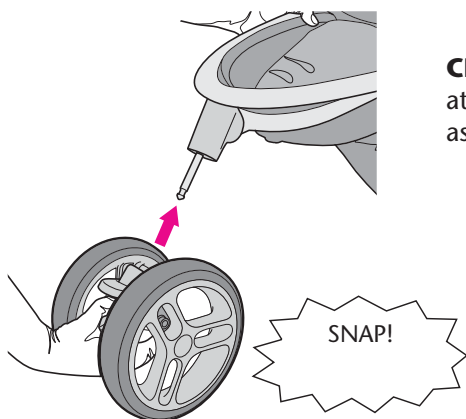
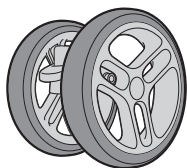

CHECK that wheel is securely attached by pulling on wheel assembly.

Rear Wheels

⚠ WARNING

Choking Hazard: Remove and immediately discard protective end cap from each wheel.

DO NOT remove rear wheels unless replacing them. Child could fall on exposed rear axle and be injured.

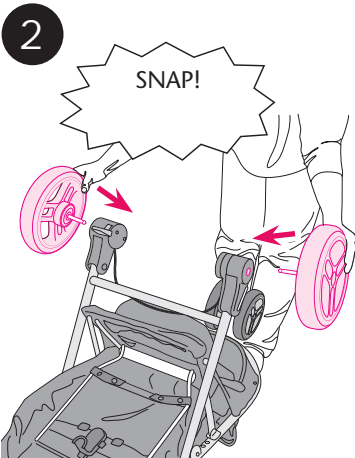
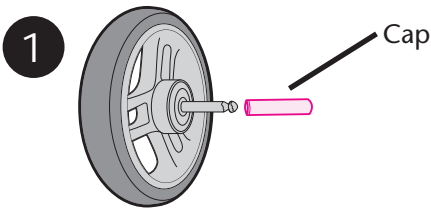
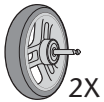

CHECK that wheels are securely attached by pulling on wheel assemblies.

Arm Bar

⚠️ WARNING Always secure your child with the seat belt. The arm bar is not a restraint device. **DO NOT** lift the stroller by the arm bar. Use care when snapping the arm bar on the stroller with a child in the stroller.

1

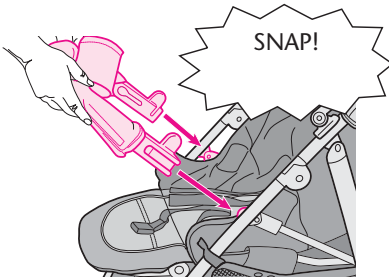

Pull on armbar to be sure it is secured.

2

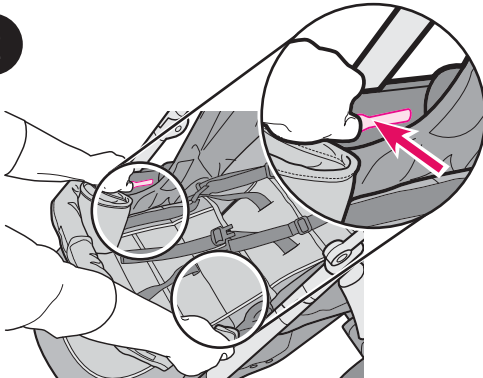

To remove, press buttons and pull arm bar out.

Parents Tray

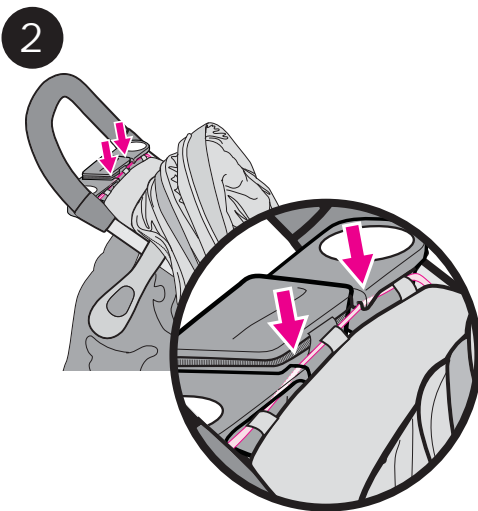
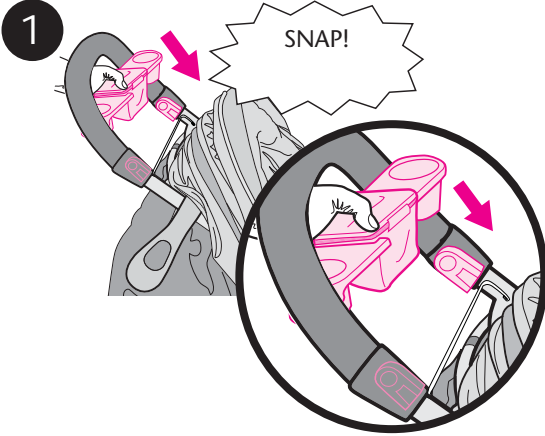
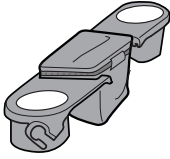

Press parent tray onto canopy wire.

5 Point Harness

1

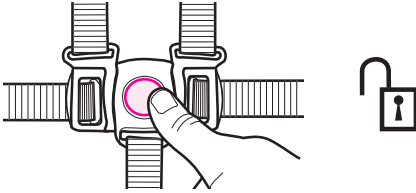

2

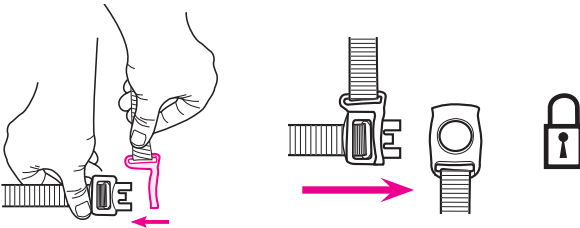

3

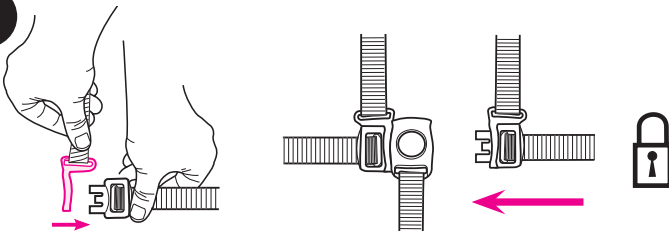

4

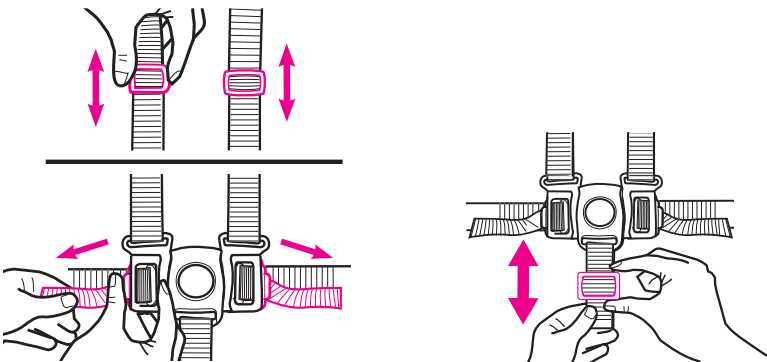

Use slide adjuster at shoulder and waist for tighter adjustment. To change shoulder harness slots.

3 Point Buckle

5

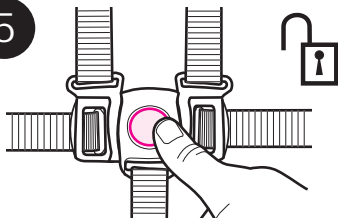

To convert to 3-pt harness.

6

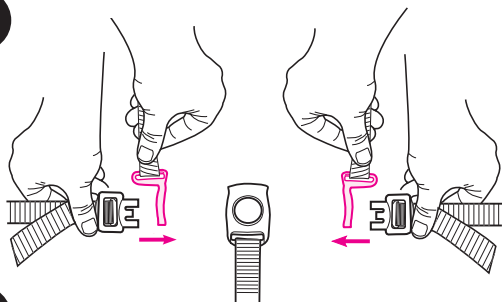

7

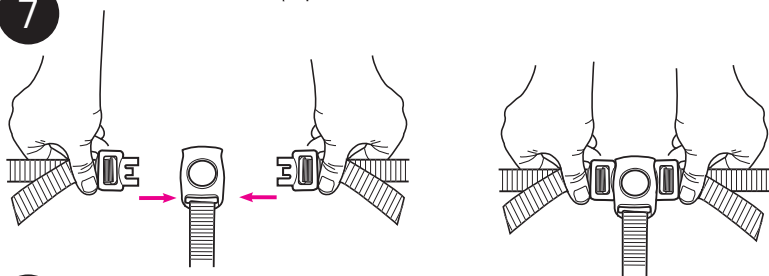

8

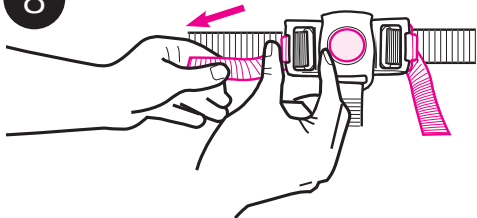

Use slide adjuster at waist for tighter adjustment.

9

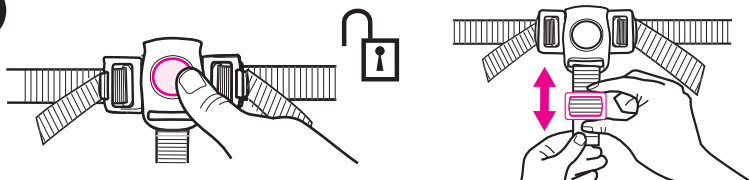

To Change Shoulder Harness Slots

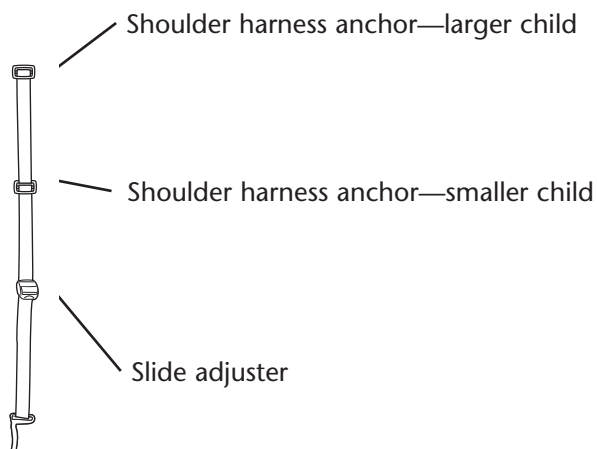

10

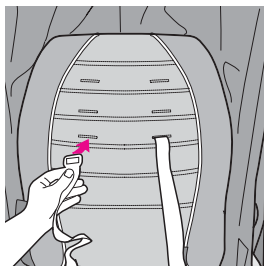

Use either shoulder harness anchor in the slots that are closest to child's shoulder height.

Use slide adjuster for further adjustment.

Brakes

⚠️ WARNING

Always apply brake. **CHECK** that the brake is on by trying to push stroller.

1

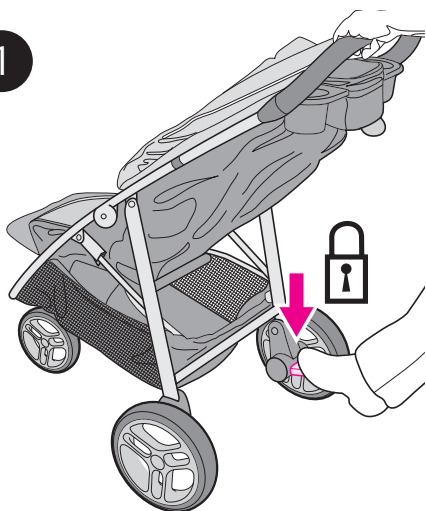

2

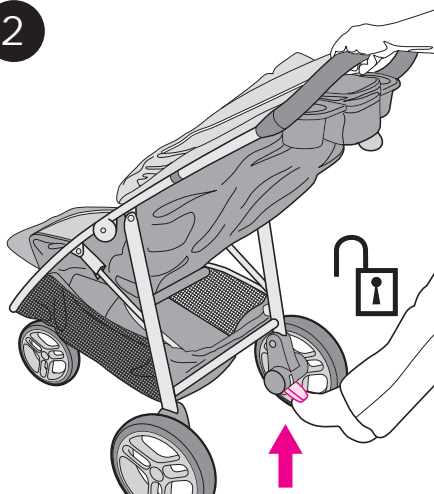

Swivel Wheel

1

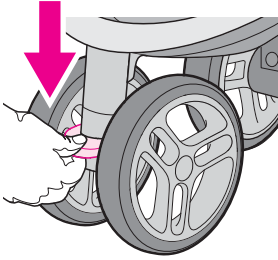

Front swivel wheel lock for use on uneven surfaces such as grass, stones or gravel.

2

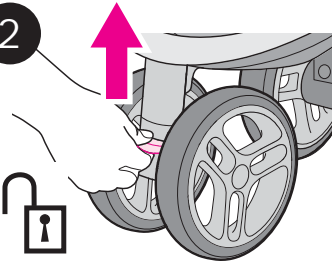

Basket



TO PREVENT A HAZARDOUS, UNSTABLE CONDITION, do not place more than 10 lbs (4.5 kg) in the storage basket.

Removing Rear Wheel

⚠ WARNING DO NOT remove rear wheels unless replacing them. Child could fall on exposed rear axle and be injured.

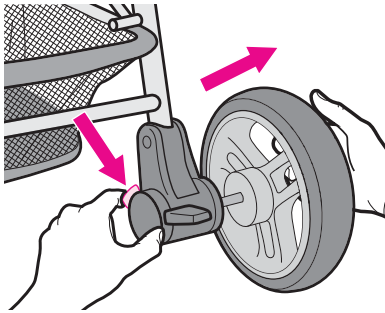

To remove wheel, push button and pull wheel off. Repeat with the other wheel.

To Recline Seat

⚠️ WARNING

When making adjustments to the stroller seat, make sure child's head, arms, and legs are clear of moving seat parts and stroller frame.

Child may slip into leg openings and strangle. Never use seat in a reclined carriage position unless pop-up enclosure is raised to cover the front opening.

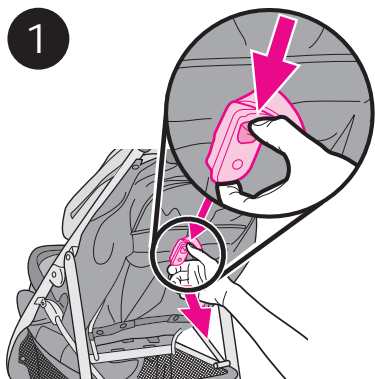

To recline, push button down and pull seat towards the rear.

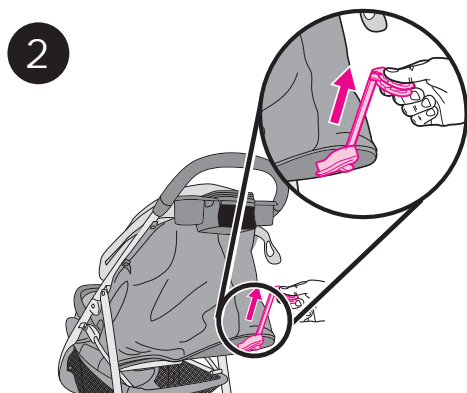

To raise, pull both straps up.

To Fold Stroller

⚠️ WARNING

DO NOT allow child to play with the fold handle.

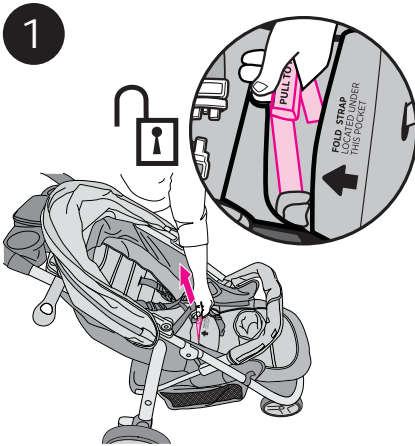

FOLD strap, located under this pocket.

Pull strap up.

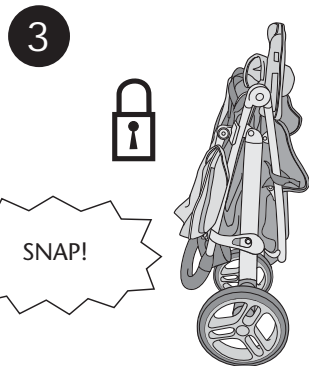
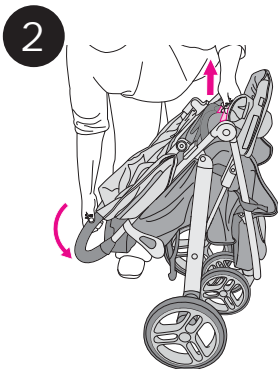

Enclosure

⚠️ WARNING

Do not use enclosure with an older child that can lift up on hands and knees or crawl out.

1

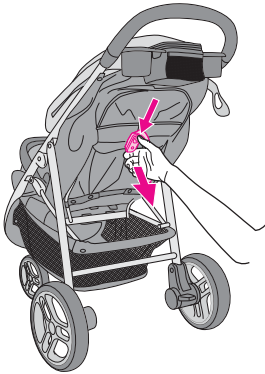

Recline the stroller seat back to its lowest position.

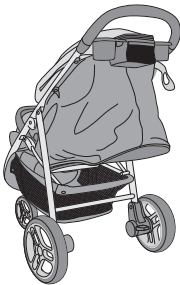

2

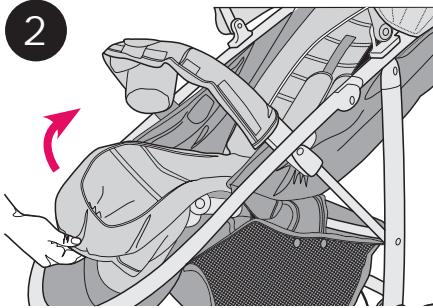

Lift enclosure.

3

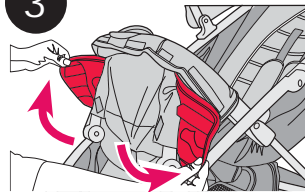

Unfasten flaps.

4

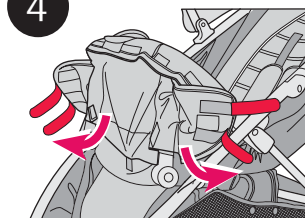

Unfasten hook and loop straps.

5

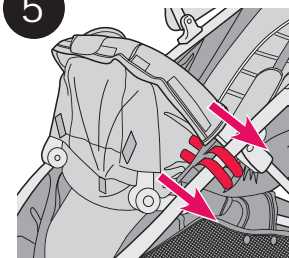

Thread straps through button holes on each side of seat cover.

6

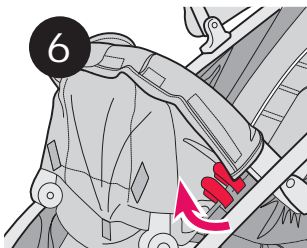

Fasten hook and loop tape on each side to secure.

To Attach Graco® Infant Car Seat

For models that do not come with an infant car seat one may be purchased separately.



▲WARNING Use only a Graco® SnugRide® Click Connect™ car seat with this travel system. (Not intended for use with SnugRide®, SnugRide® 30, SnugRide® 32, SnugRide® 35, Infant SafeSeat™, AUTOBABY, LOGICO S, JUNIORBABY and ASSURA infant car seats.) If unsure of the model or for more information please call Graco's customer service. Improper use of this stroller with other manufacturers' car seats may result in serious injury or death. Read the manual provided with your Graco car seat before using it with your stroller.

▲Always secure your child with the car seat harness when using the car seat in the stroller. If your child is already in the car seat, **check that the child is secured with the harness.**

1

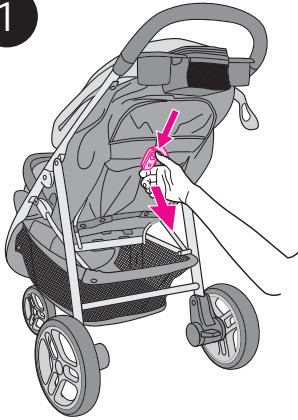

Recline the stroller seat back to its lowest position.

Be sure canopy is in the rearward position before attaching the infant carseat.

2

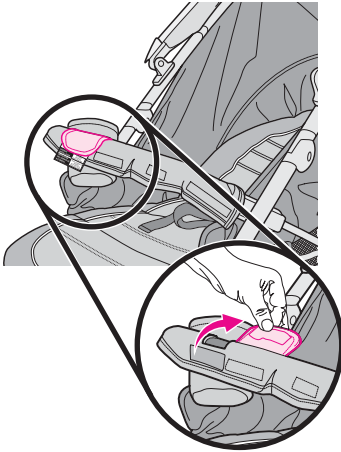

Pull on armbar to be sure it is secure. Open carseat attachment flap as shown.

3

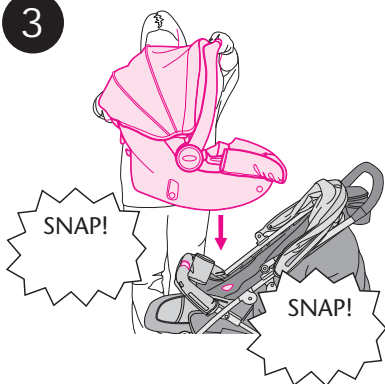

Insert car seat into stroller and push down on car seat until the latches snap into the Click Connect™ mounts.

4

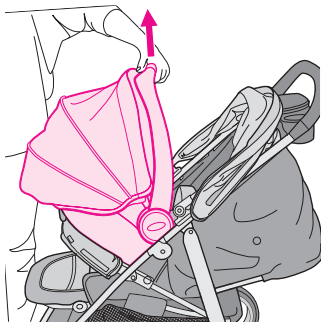

CHECK that infant car seat is securely attached by pulling up on it.

5

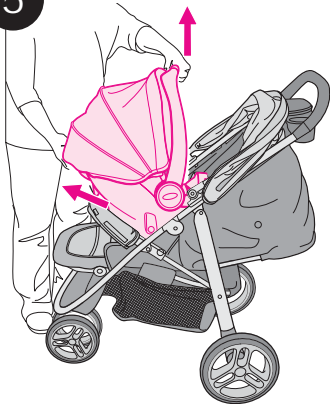

To remove car seat: squeeze release handle at back of car seat, and lift car seat out of the stroller.

Care and Maintenance

- **TO CLEAN SEAT COVER**, Refer to your care tag on your seat pad for washing instructions. NO BLEACH.
- **TO CLEAN STROLLER FRAME**, use only household soap and warm water. NO BLEACH or detergent.
- **FROM TIME TO TIME CHECK YOUR STROLLER** for loose screws, worn parts, torn material or stitching. Replace or repair the parts as needed. Use only Graco replacement parts.
- **EXCESSIVE EXPOSURE TO SUN OR HEAT** could cause fading or warping of parts.
- **IF STROLLER BECOMES WET**, open canopy and allow to dry thoroughly before storing.
- **IF WHEEL SQUEAKS**, use a light oil (e.g., WD-40, 3-in-1, or sewing machine oil). It is important to get the oil into the axle and wheel assembly as illustrated.
- **WHEN USING YOUR STROLLER AT THE BEACH** completely clean your stroller afterward to remove sand and salt from mechanisms and wheel assemblies.

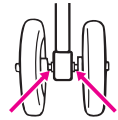



SnugRide®
Click Connect™35

Read this manual
KEEP INSTRUCTIONS FOR FUTURE USE.

Even if using this child restraint seems easy to figure out on your own, it is very important to READ, UNDERSTAND AND FOLLOW THE OWNER'S MANUAL.

Failure to use this child restraint properly increases the risk of serious injury or death in a sudden stop or crash.

1.0 Warnings to Parents and Other Users

WARNING

DO NOT PLACE THIS INFANT RESTRAINT IN A VEHICLE SEATING LOCATION THAT HAS A FRONT AIR BAG. If the air bag inflates, it can hit the infant restraint with great force and cause serious injury or death of your child. Check vehicle owner's manual for information about side air bags and infant restraint installation. No infant restraint can guarantee protection from injury in every situation. However, proper use of this infant restraint reduces the risk of serious injury or death to your child.



Failure to properly use this infant restraint increases the risk of serious injury or death in a sharp turn, sudden stop or crash. Your child's safety depends on you installing and using this infant restraint correctly on every ride.

Even if using this infant restraint seems easy to figure out on your own, it is very important to **FOLLOW THE OWNER'S MANUAL**.

The manual is located in the base.

You also must read your vehicle owner's manual.

Your child's safety depends on:

1. **Choosing a suitable location in your vehicle.** Some seating positions, such as those equipped with air bags, may not be safe locations for this infant restraint.
2. **Inserting the harness straps in the proper slots for your child.**
3. **Properly securing your child in the infant restraint.**
4. **Placing infant restraint/base in a rear-facing position.**
5. **Properly routing the vehicle seat belt or LATCH.**
6. **Properly reclining the infant restraint.**
7. **Properly securing the infant restraint in the vehicle using a seat belt designed to restrain an infant restraint or by using LATCH.** Many seat belts are NOT safe to use with infant restraints, even though they can easily be threaded through the infant restraint!

2.0 Registration Information

Model Number: _____

Date of Manufacture: _____

Purchase Date: _____

2.1 Register Your Infant Restraint

Please fill in the above information. The **model number and date of manufacture** can be found on a label on the bottom of your infant restraint. Fill out the prepaid registration postcard attached to the seat pad and mail it today.

Child restraints could be recalled for safety reasons. You must register this restraint to be reached in a recall. **Send your name, address and the restraints' model number and date of manufacture.**

2.2 If You Need Help

In the U.S.A, please contact our Customer Service Department with any questions you may have concerning parts, use, or maintenance. When you contact us, please have your product's **model number and date of manufacture** ready so that we may help you quickly. These numbers can be found on a sticker on the underside of your infant restraint.

2.3 Child Restraint/Base Useful Life

STOP using this child restraint or base and throw it away 7 years after the date of manufacture.

Look for this sticker on rear of infant restraint or on the base:

MODEL	NAME
Date of Manufacture	_____
	year month
Made in China	

3.0 Important Information

3.1 Warnings for Use as an Infant Restraint

WARNING

- **DO NOT INSTALL OR USE THIS INFANT RESTRAINT AND BASE UNTIL YOU READ AND UNDERSTAND THE INSTRUCTIONS IN THIS MANUAL AND IN YOUR VEHICLE OWNER'S MANUAL.** DO NOT let others install or use the infant restraint unless they understand how to use it.
- **FAILURE TO PROPERLY USE THIS INFANT RESTRAINT AND BASE INCREASES THE RISK OF SERIOUS INJURY OR DEATH IN A SUDDEN STOP OR CRASH.** Your child can be injured in a vehicle even if you are not in a crash. Sudden braking and sharp turns can injure your child if the infant restraint is not properly installed or if your child is not properly secured in the infant restraint.
- **PLACE THIS INFANT RESTRAINT ONLY IN A REAR-FACING POSITION** when using it in the vehicle.
- **SOME CHILDREN WITH SPECIAL NEEDS**, such as pre-term babies or those who have tested positive for positional apnea, may be at increased risk of suffering breathing or other difficulties in an infant restraint. If your child has special needs, we recommend that you have your physician or hospital staff evaluate your child and recommend the proper infant restraint or car bed before using this product.

- According to crash statistics, **CHILDREN ARE SAFER WHEN PROPERLY RESTRAINED IN REAR VEHICLE SEATING POSITIONS, RATHER THAN FRONT SEATING POSITIONS.** For a vehicle with a front passenger air bag, refer to your vehicle owner's manual as well as these instructions for infant restraint installation.
- **NEVER LEAVE YOUR CHILD UNATTENDED.**
- **NEVER LEAVE AN INFANT RESTRAINT AND BASE UNSECURED IN YOUR VEHICLE.** An unsecured infant restraint or base can be thrown around and may injure occupants in a sharp turn, sudden stop or crash. Remove it or make sure that it is securely belted in the vehicle. If not using **LATCH**, make sure unsecured **LATCH** connectors are properly stored in base.
- **REPLACE THE INFANT RESTRAINT AND BASE AFTER A CRASH OF ANY KIND EVEN IF INFANT RESTRAINT WAS UNOCCUPIED.** A crash can cause damage to the infant restraint that you may not be able to see.
- **DO NOT MODIFY YOUR INFANT RESTRAINT AND BASE** or use any accessories or parts supplied by other manufacturers.
- **NEVER USE INFANT RESTRAINT AND BASE IF IT HAS DAMAGED OR MISSING PARTS.** DO NOT use a cut, frayed or damaged infant restraint harness, vehicle seat belt or **LATCH** belt.
- **THE INFANT RESTRAINT CAN BECOME VERY HOT IF LEFT IN THE SUN.** Always touch the surface of any metal or plastic parts before putting your child in the infant restraint.
- **THIS INFANT RESTRAINT CONFORMS** to all applicable Federal Motor Vehicle Safety Standards and is certified for use in motor vehicles and aircraft.

- **NEVER** give this infant restraint and base to someone else without also giving them this manual.
- **NEVER** use a second-hand infant restraint and base or a infant restraint whose history you do not know.

3.2 Warnings for Use With a Stroller

- **USE ONLY WITH STROLLERS THAT ARE PART OF THE GRACO CLICK CONNECT™ TRAVEL SYSTEM.** Refer to stroller owner's manual for details about how to attach the infant restraint to your stroller.



- Never use a Graco infant restraint with other manufacturer's strollers, as this may result in serious injury or death.

3.3 Additional Warnings for Use as a Carrier

WARNING

- **FALL HAZARD:** Child's movements also can move carrier. **NEVER** place carrier on edges of countertops, tables or other high surfaces. Always stay within arms reach whenever carrier is not on floor/ground.
BE SURE handle locks into position before lifting carrier.
NEVER place carrier on the top of a shopping cart.
- **SUFFOCATION HAZARD:** Infant carrier can roll over on soft surfaces and suffocate child. Never place carrier on beds, sofas or other soft surfaces.
- **STRANGULATION HAZARD:** Children have **STRANGLED** in loose or partially buckled harness straps. Fully restrain the child even when carrier is used outside the vehicle.
KEEP STRINGS AND CORDS AWAY FROM CHILD. Strings and cords can cause strangulation.
DO NOT place carrier near a window where cords from blinds or drapes can strangle a child.
DO NOT hang strings on or over the carrier.
DO NOT place items with a string around a child's neck, such as hood strings, pacifier cords, etc.
DO NOT attach strings to toys.

3.4 Height and Weight Limits

⚠ WARNING

TO AVOID SERIOUS INJURY OR DEATH, DO NOT USE THE INFANT RESTRAINT WITH A CHILD LARGER OR SMALLER THAN THE WEIGHT AND HEIGHT RANGE LISTED BELOW.

Your child **MUST** meet the following requirements:

- **WEIGHT:** 4-35 lbs. (1.8 kg-15.87 kg)

AND

- **HEIGHT:** 32 inches (81 cm) or less in height.

IMPORTANT: MAKE SURE the top of the child's head is at least 1" below the top of the infant restraint.



4.0 Choosing an Appropriate Vehicle Seat Location

4.1 Vehicle Seat Requirements

⚠ WARNING

IMPROPER PLACEMENT OF THE INFANT RESTRAINT INCREASES THE RISK OF SERIOUS INJURY OR DEATH. Some seating positions in your vehicle may not be safe for this infant restraint. Some vehicles do not have any seating positions that can be used safely with the infant restraint. If you are not sure where to place the infant restraint in your vehicle, consult your vehicle owner's manual or call Graco.

- Whenever possible, secure the infant restraint in the center position of the seat directly behind the front seats ❶. If you want to use LATCH, check your vehicle owner's manual for LATCH locations.



- **NEVER** place this infant restraint in a vehicle seating location that has a front air bag ❷. See "3.1 Warnings for Use as an Infant Restraint".



- The VEHICLE seat must face forward.

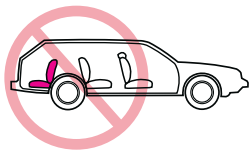

- DO NOT use infant restraint on vehicle seats with seat backs that will not lock in an upright position. DO NOT use seats that can fold down without having to release a lock or latch of some kind. These seats can fly forward and strike the child in a sudden stop or crash.

4.2 Vehicle Seat Belt Requirements

⚠ WARNING

A FEW SEAT BELT SYSTEMS ARE NOT SAFE TO USE WITH THE INFANT RESTRAINT. THE VEHICLE SEAT BELT MUST BE DESIGNED TO HOLD THE INFANT RESTRAINT TIGHTLY AT ALL TIMES.

Pay careful attention to these systems; some of the seat belts that are not safe to use look very much like seat belts that are safe to use. If you are unsure, consult your vehicle owner's manual or call Graco.

4.2.1 UNSAFE Vehicle Belt Systems

LATCH can be used IN PLACE OF the vehicle belt system. Please refer to vehicle owner's manual for LATCH locations.

DO NOT use any of the following systems to secure the infant restraint.

- Lap Belts with Emergency Locking Retractor (ELR)

This lap belt stays loose and can move until it locks in a crash or sudden stop.



- Combination Lap/Shoulder Belt with Retractor
Each strap has a retractor at one end and is attached to the latch plate at the other end.

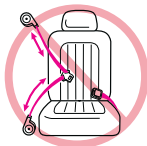

- Passive Restraint - Lap Belt with Motorized Shoulder Belt

- Passive Restraint - Lap or Shoulder Belt Mounted on Door

DO NOT use vehicle belts that are attached to the door in any way or that move along a track to automatically surround the passenger when the door is closed.

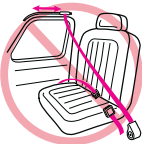
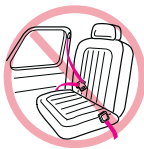

- Lap Belts Forward of Seat Crease

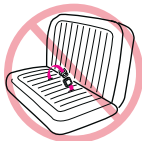

4.2.2 **SAFE** Vehicle Belt Systems

THE FOLLOWING BELT SYSTEMS CAN BE USED WITH YOUR INFANT RESTRAINT, IF the seat location meets all other requirements of these instructions and those in your vehicle owner's manual. **LATCH** can be used in place of the vehicle belt system in designated locations. Please refer to vehicle owner's manual for **LATCH** locations.

When using infant restraint without the base, adjust the belt as described in this section for these types of vehicle seat belts.

Some vehicle lap/shoulder seat belts have a plastic button on the belt. Do not allow the button to interfere with the belt routing through the vehicle belt path when installing the seat alone.

- Lap Belts - Manually Adjusted

Belt tail

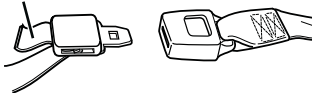

When buckled, the belt is tightened manually by pulling on the belt tail while pushing down hard on the infant restraint.

- Lap Belts with Automatic Locking Retractor (ALR)



The automatic locking retractor will not permit the lap belt to lengthen once it is buckled. Tighten the belt by feeding the belt back into the retractor while pushing down hard on the infant restraint.

- Combination Lap/Shoulder Belt with Locking Latch Plate

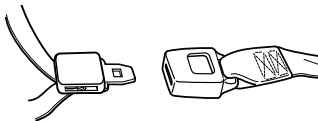

Once it is buckled, this type of belt has a latch plate that will not allow the lap portion of the belt to loosen. Belt is tightened by pulling hard on the shoulder portion of the vehicle belt while pushing down hard on the infant restraint.

- **Combination Lap/Shoulder Belt with Sliding Latch Plate**

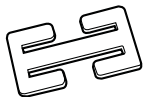
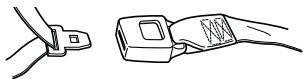

Locking clip

This belt has a latch plate that slides freely along the belt.

This belt **MUST** be converted to prevent movement of the lap portion of the belt. You must use a **locking clip** (provided with the infant restraint) when using the infant restraint **without** the base unless your vehicle's seat belt can be converted in another way as described in your vehicle owner's manual.

To Install Locking Clip:

1. Tighten the buckled belt by pushing down hard on the infant restraint and pulling hard on the shoulder belt.
2. While pushing down on the infant restraint, pinch the two straps together behind the buckle tongue. Unbuckle the belt without allowing it to slip.
3. Connect lap and shoulder belts with locking clip as shown **1** and **2**.
4. Rebuckle belt. Check that lap belt does not move by pulling and pushing hard on the infant restraint. If belt loosens or lengthens, repeat procedure.

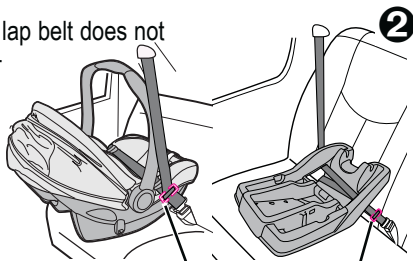
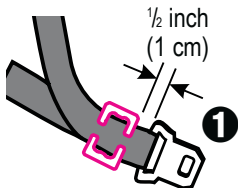

Locking clip goes here,
1/2 inch (1 cm) from the buckle

4.3 LATCH Locations

Newer vehicles may have one or more seating positions with LATCH anchorage systems. If vehicle is equipped with LATCH, the vehicle lower anchor points may be visible at the vehicle seat crease. If not visible, they may be marked with the symbol .

See your vehicle owner's manual for exact locations, anchor identification, and requirements for use with an infant restraint.

LATCH lower vehicle anchor points are defined as 11 inches from the center of one LATCH anchor to the center of another LATCH anchor. If allowed by your Vehicle Owners Manual, the center seating position may be used if the anchor spacing is 11" or greater.

Typical seat in a passenger vehicle.
Other vehicle types may have different LATCH locations or different markings.

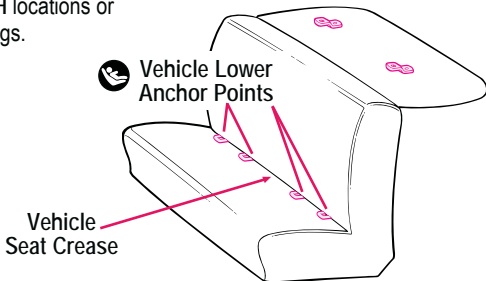

5.0 Features and Components

FRONT VIEW

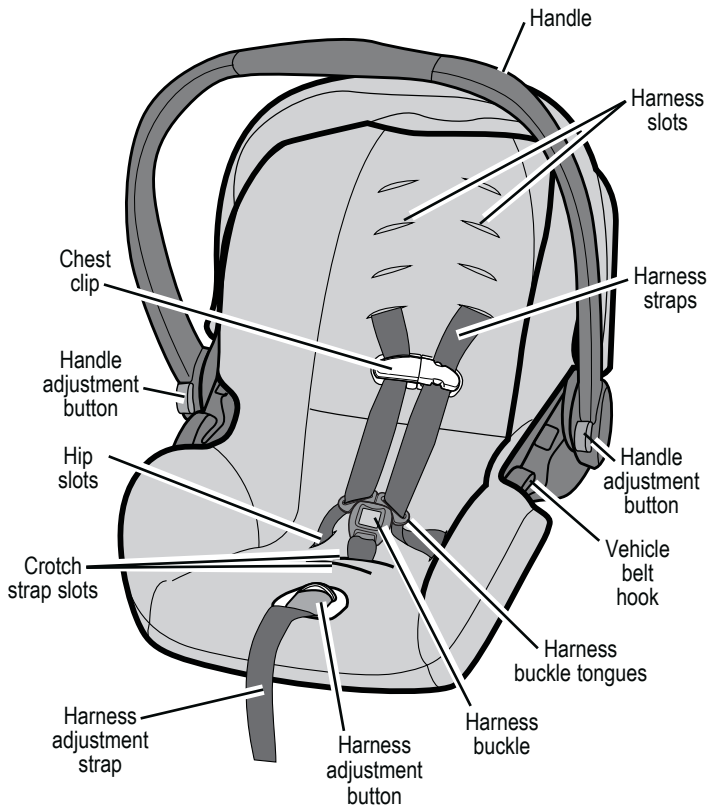

REAR VIEW

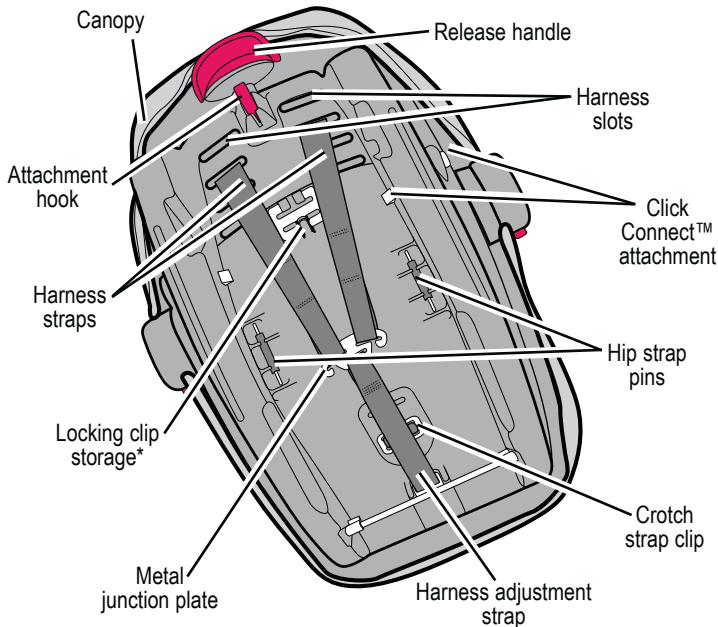

*Locking
Clip



The locking clip is stored on the bottom of the infant restraint. You will need to use it with certain types of vehicle lap/shoulder seat belts.

BASE

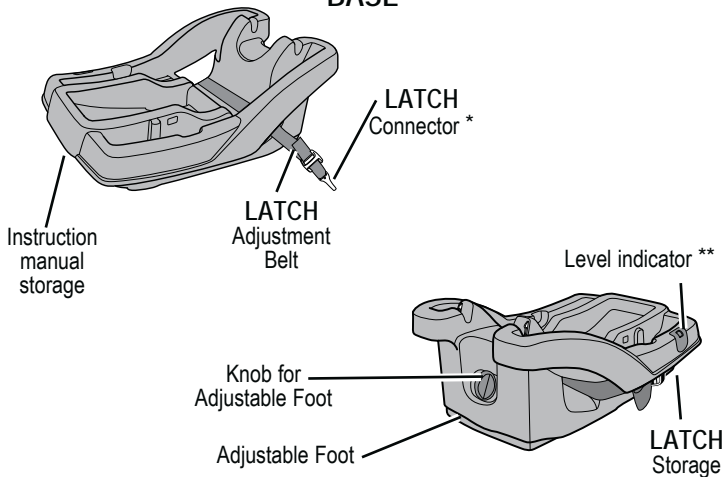

United States Federal Motor Vehicle Safety Standards have defined a system for installing car seats in vehicles. The system is called LATCH.

* LATCH may be used **IN PLACE** of vehicle belt **ONLY** if vehicle is equipped with LATCH anchor points. Please refer to vehicle owner's manual for LATCH locations.

**Level Indicator



The level indicator is attached to the side of the base and indicates whether or not the infant restraint is properly reclined.

5.1 Adjusting Handle

1. Press handle adjustment buttons on both sides of handle ❶.
2. Rotate handle until it clicks into any of the 4 positions:

Position A: **MUST** be used
when carrying by handle,

Position A,B,C,D: may be used in vehicle.

BOTH handle adjustment
buttons must pop out to lock
handle in place ❷.

3. Push and pull on the handle
to be sure it is locked firmly in
position.

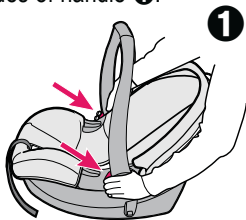

Carrying A

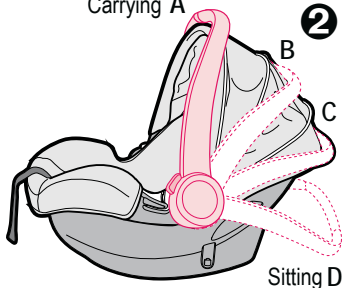

5.2 Removing and Attaching Infant Restraint

To remove, squeeze release handle at back of infant restraint and lift out of base as shown ❸.

To put infant restraint in base, push infant restraint down until it clicks into base. Pull up on infant restraint to be sure it is latched firmly into base.

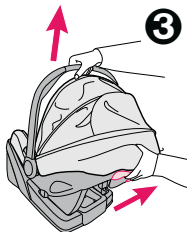

5.3 Cold Weather Boot (on certain models, styles vary)

Some models come with a cold weather boot. To use, slide boot on end of seat and attach plastic flaps as shown.

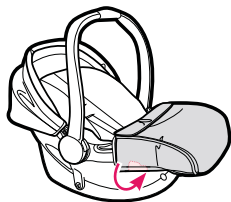

5.4 Canopy Attachment

Attach canopy by inserting canopy bow into slots in canopy mounts on both sides of infant restraint as shown **1**.

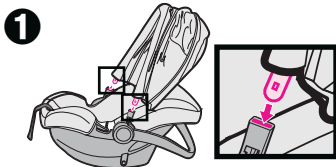

Pull canopy over back of infant restraint **2**.

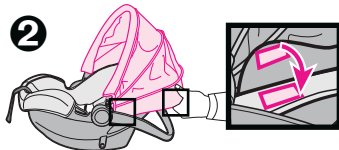

To remove, press button on canopy mount and pull canopy bow out of slot, repeat on other side **3**.

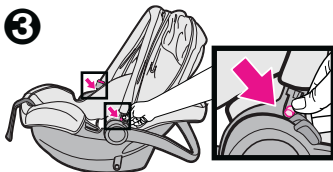

5.5 Head Support, Body Support and Harness Covers (on certain models, styles vary)

⚠ WARNING

To prevent ejection in sudden stop or crash:

- Always make sure shoulder straps are threaded through slots and properly positioned on shoulders.
- Never allow body support to bunch or fold behind child.
- Only use head support with bottom 2 sets of harness slots.
- Make sure that harness covers do not interfere with placement of the chest clip at armpit level.

Some infants may need extra support to keep their head and body in a comfortable position.

Thread the harness through the openings in the head and body support as shown ❶ and ❷.

MAKE SURE THAT NOTHING INTERFERES WITH THE HARNESS. Harness must still be flat and snug against your child's shoulders.

If your model does not include a body support, you can use a rolled towel as shown ❸.

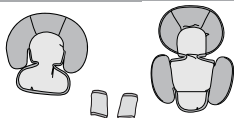

6.0 How to Install the Infant Restraint/Base

6.1 Installing the Infant Restraint Without Base Using Vehicle Belt

You must carefully follow the instructions provided by your vehicle manufacturer, in addition to the information in this manual. Before proceeding be sure you have read and understood section 4, “Choosing an Appropriate Vehicle Seat Location” on pages 13-19.

Make sure the buckle tongue goes into the correct buckle **1**. The seat belt should not be twisted or turned.

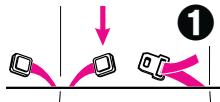

Make sure vehicle is on level ground **2** so that the level indicator can be used to properly recline the infant restraint.

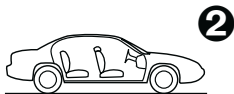

Refer to your vehicle owner’s manual and the instructions in “4.2.2 SAFE Vehicle Belt Systems”, page 16-18, on tightening your vehicle belt when using the infant restraint without base.

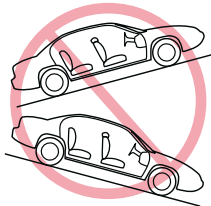

If a front passenger seat is used (see air bag warning, page 4), slide the vehicle seat rearward as far as possible from the dashboard. If a rear seat is used, make sure the seat in front of it is moved forward enough and is upright enough to allow room for the infant restraint.

1. Place the infant restraint without base in a rear-facing position in a vehicle seat.
2. Thread the lap belt or lap portion of a lap/shoulder belt under both vehicle belt hooks:

Lap Belt

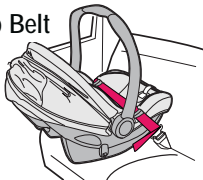

Lap/Shoulder Belt

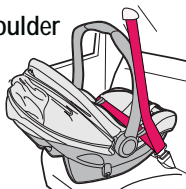

3. Buckle the vehicle belt.
4. Tighten the vehicle seat belt. To create a secure installation, push down hard with your free hand on the infant restraint ③ and pull and tighten the vehicle belt.
5. Check infant restraint is level: Red level line on the warning label MUST be level with the ground ④.
6. Test infant restraint for secure installation as described in infant restraint "Final Safety Check" page 42.

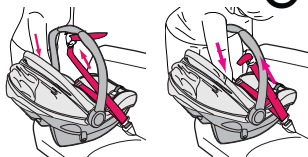

6.2 Installing the Infant Restraint and Base Using Vehicle Belt

1. Make sure vehicle is on level ground in order to get the correct recline position.

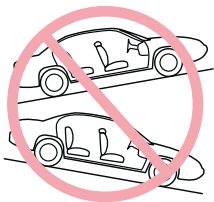
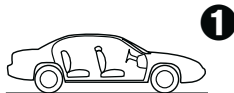

2. Place the base in a rear-facing position on a forward-facing vehicle seat.

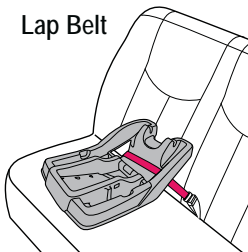

2. Place the base in a rear-facing position on a forward-facing vehicle seat.

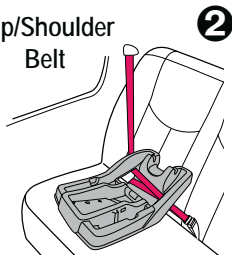

3. Buckle the seat belt. Make sure the buckle tongue goes into the correct buckle ③. The seat belt should not be twisted or turned.

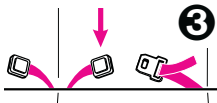

4. To create a secure installation, while pushing down on the base, pull the free end of the lap belt or the shoulder portion of the lap/shoulder belt to tighten ④.



5. Check that belt does not move by pulling and pushing hard on base with hands near the vehicle belt path. If belt loosens or lengthens, repeat procedure.

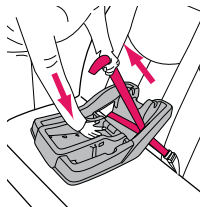

6. Push the infant restraint down into the base and make sure that you hear a “click” ⑤. Pull up on the infant restraint to be sure it is latched securely into the base.

If the infant restraint does not securely latch into the base, the infant restraint provides **NO** protection for your child. **DO NOT** use the infant restraint/base if the infant restraint does not securely latch into the base.

7. Test infant restraint for secure installation as described in infant restraint “Final Safety Check” page 42.

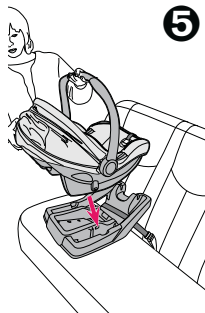

6.3 Using LATCH to Install Base

1. **MAKE SURE** vehicle is on level ground. Make sure to check your vehicle owner's manual for LATCH seating positions.

2. For ease of installation, press button to extend LATCH to its **MAXIMUM LENGTH** ❶.



3. Position base in vehicle seat as shown.

4. Make sure LATCH is through vehicle/LATCH belt path normally used for vehicle seat belt. ❷. Belt must lie flat and not be twisted.

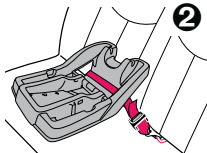

5. Attach connectors to vehicle lower anchors. Pull firmly on connectors to be sure they are attached ❸.



6. Tighten LATCH by pushing down hard on base and pulling the adjustment belt back through belt path ❹.

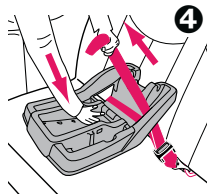

7. NEVER put two LATCH connectors on one vehicle LATCH anchor ⑤.

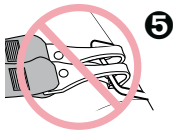

8. Test infant restraint for secure installation as described in infant restraint “Final Safety Check” page 42.

9. Check that the LATCH stays tight and does not slip from the tightened position. If it does not stay tight, try another seating position or contact Graco.

10. To remove LATCH, push button while pulling on the LATCH belt as shown ⑥.

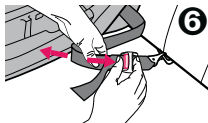

11. Press and hold LATCH release hinge ⑦.



12. Push connector in, lift connector up and pull out (away from anchor point) ⑧.

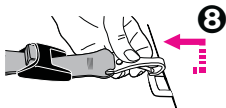

13. Repeat steps 11 and 12 for other connector.

6.4 Reclining Infant Restraint/Base

For your child's safety, it is important that your infant restraint/base be properly reclined. Attached to the side of your infant restraint is a level indicator to help properly recline the infant restraint/base on the vehicle seat.

WARNING

Failure to properly recline the infant restraint on the vehicle seat increases the risk of serious injury or death.

If the infant restraint is too upright, a child's head may drop forward and cause breathing problems.

If the infant restraint is too reclined, a crash could put too much force on a child's neck and shoulders.

The infant restraint must be properly reclined according to the following instructions.

Infant restraint must be properly reclined. Too upright can result in breathing difficulties.



USING INFANT RESTRAINT ONLY:

- 1) Red level line on warning label on infant restraint **MUST** be level with the ground.

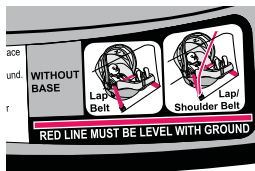

USING INFANT RESTRAINT AND BASE TOGETHER:

1) Vehicle **MUST** be level with ground to get correct recline position.

2) Use level indicator on base. When reading the level indicator on base, view it directly from side of the indicator.

Check the level indicator. You must look straight on at the indicator.

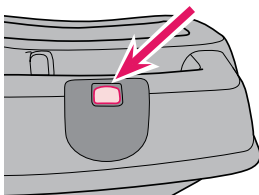

WHEN READING THE LEVEL INDICATOR,

Use corrected age for preemies.

- If the indicator shows light blue in the window, the restraint is level for infants 0+ months in age.



0+ months
(meses)

- If the indicator shows light blue and dark blue in the window, the restraint is level for a child 3+ months in age.



3+ months
(meses)

- If any **RED** is showing, child restraint is **NOT** level. You must adjust your recline position.



To Adjust Recline on Base:

Turn the knob counter clockwise to the desired setting to lower the foot ❶.

Turn the knob clockwise to raise the foot ❷.

If there is still red in the level indicator when the foot is completely extended then raise the foot and place a rolled towel under the foot ❸ until ONLY blue shows.

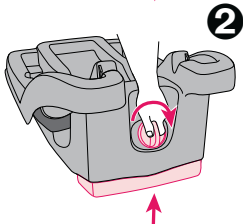
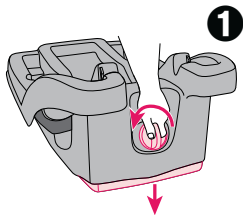

When using only the infant restraint without the base, CHECK infant restraint is level with the ground. Red level line on the warning label (see step ❹ on pg 27) MUST be level with the ground.

If the infant restraint is resting on the vehicle seat and is still not level then place a rolled towel under the infant restraint ❹.

Re-adjust the vehicle seat belt as necessary to secure the infant restraint firmly in the vehicle seat.



7.0 Using Infant Restraint

7.1 Positioning Harness Straps

WARNING

FAILURE TO PROPERLY ADJUST THE HARNESS STRAPS FOR YOUR CHILD INCREASES THE RISK OF SERIOUS INJURY OR DEATH IN THE EVENT OF A SHARP TURN, SUDDEN STOP, OR CRASH. The harness straps must be properly adjusted to fit your child according to the following instructions.

1. Remove infant restraint from base and rotate handle down to sitting position. See “5.1 Adjusting Handle” and “5.2 Removing and Attaching Infant Restraint”, page. 23.
2. Place child in seat as shown **1**.
3. Determine which pair of harness slots are even with or just below your child’s shoulders **2**.
4. If the harness straps must be adjusted: remove child from infant restraint and move harness straps to the proper harness slots by doing the following:

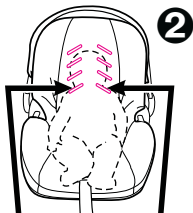

Use harness slots even with or just below child's shoulders

A. Push the harness adjustment button under the seat flap. Pull the shoulder straps out to loosen the harness ③.

B. From behind seat, remove the ends of the two shoulder straps from the metal junction plate ④.

C. From front, pull straps through the harness slots and then reinsert them through the appropriate slots. Both harness straps must be through the same set of slots in the seat and pad.

D. Depending on the size of your child, you may need to adjust the harness straps as shown on page 37. Reassemble the strap ends onto the metal junction plate ④.

5. **SAFETY CHECK:**

a) **CHECK** that straps are not twisted in front or back;

b) **CHECK** that straps are secure by pulling on harness straps from the front of the seat.

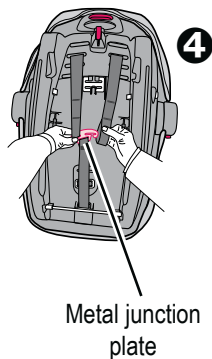
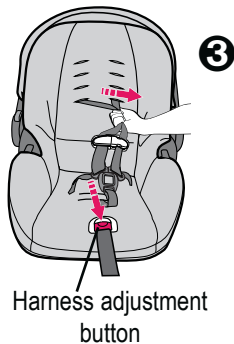

Shoulder Straps for a SMALLER Baby:

Use the lower 2 sets of harness slots ❶ (if they are even with or just below your child's shoulders) and the upper strap loops ❷. The ends of the straps must hang in front of the metal junction plate as shown in ❷, not as shown in ❸.

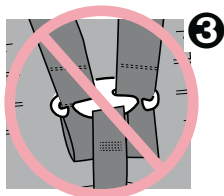
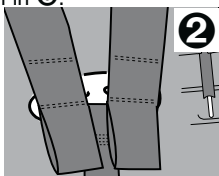
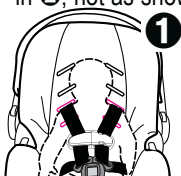

CHECK that the loops are completely within junction plate slots ❹.

CHECK that straps are secure by pulling on them.



Shoulder Straps for a LARGER Baby:

Use top 2 sets of harness slots ❺ and the end strap loops ❻ (if they are even with or just below your child's shoulders).

CHECK that the loops are completely within junction plate slots ❻.

CHECK that straps are secure by pulling on them.

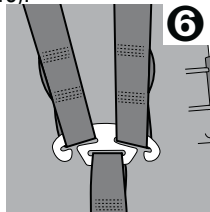
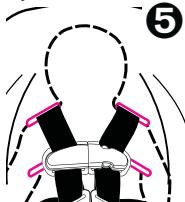

7.2 Changing the Crotch Strap Position

FOR SMALLER BABIES:

Turn infant restraint over and push crotch strap clip through the front crotch slot ❶ and seat pad. Re-insert clip through the front of seat pad into the rear crotch slot and seat as shown.

Crotch strap clip should remain flat against seat.

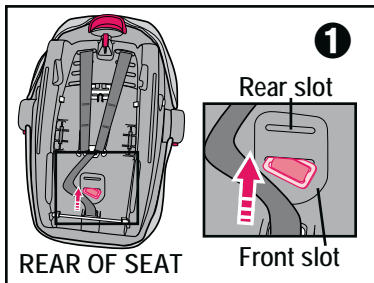

FOR LOW BIRTH WEIGHT INFANTS (MINIMUM WEIGHT IS 4LB.), shoulder straps should be in the lowest set of harness slots and the upper strap loops (see page 37).

FOR LARGER BABIES:

Turn infant restraint over and remove crotch strap clip by pushing clip through the rear crotch slot and seat pad ❷. Re-insert it through the front of seat pad ❸ into the front crotch slot and the seat.

Crotch strap clip should remain flat against seat.

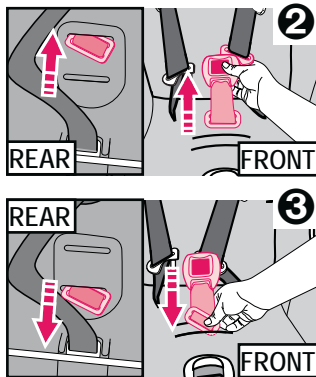

7.3 Securing Child in the Infant Restraint

⚠ WARNING

Failure to properly secure your child in the infant restraint/carrier increases the risk of serious injury or death from suffocation or falls, or in the event of a sudden stop or crash. Even when used only as a carrier, make sure the harness straps are properly secured.

1. Move infant restraint handle to sitting position (see page 23).

2. Press button on front of infant restraint and pull the harness to loosen ❶.

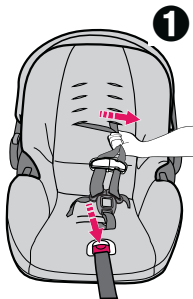

3. Open chest clip by squeezing both sides and unbuckle as shown ❷.

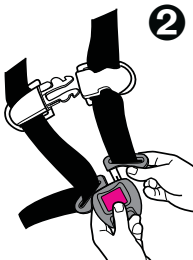
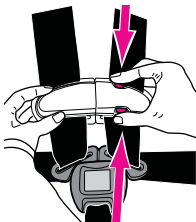

4. Place your child in the infant restraint as shown in ③, not ④. Place the harness straps around your child.



5. Insert the two buckle tongues into the harness buckle on the crotch strap. Make sure that you hear each tongue click into the buckle ⑤.

DO NOT use the infant restraint if the buckle tongues do not latch in place. Call Graco.

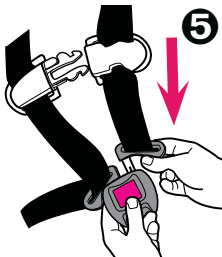

6. Snap chest clip pieces together ⑥.

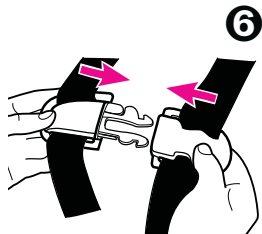

7. Pull on harness adjustment strap to tighten straps as shown ⑦.
CHECK that both straps are flat and snug on shoulders and thighs.



8. Position chest clip in middle of chest, level with armpits and away from the neck ⑧.

9. SAFETY CHECK:

a) CHECK that harness straps are not twisted.

b) CHECK that the harness is snug. You should not be able to pinch the harness strap if it is snug. A snug strap should not allow any slack. It lies in a relatively straight line without sagging. It does not press on the child's flesh or push the child's body into an unnatural position ③.

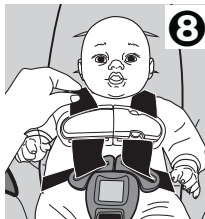

Final Safety Check: Every time you drive with your child,

PUSH DOWN on the top of the infant restraint slowly but firmly to make sure the vehicle belt does not lengthen at all and that the vehicle belt or LATCH is fastened securely around the infant restraint/base **1**.



Holding the infant restraint **2** or base **3** near the vehicle belt path, **TURN AND PULL** the infant restraint forward and to both sides to make sure the vehicle belt or LATCH does not lengthen or loosen and the infant restraint does not easily move. The infant restraint should not move side to side or front to back more than 1 inch (2.5 cm).

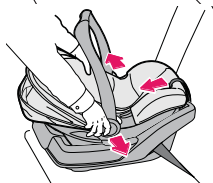
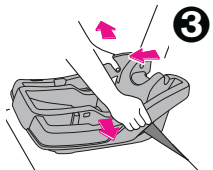
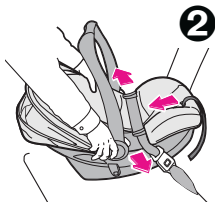

8.0 Additional Information

8.1 Airplane Use

When installing in an airplane using the base, install the same way as in an automobile with a lap only belt. If using the infant restraint only, install following the same instructions as in an automobile. Notify the airline ahead of time that you intend to bring the seat on board.



Use only in forward-facing aircraft seats. Follow the flight attendants instructions about infant restraint placement. Do not use this infant restraint if the airplane seat belt does not hold the infant restraint securely.

8.2 Storing LATCH

1. For ease of storing, extend LATCH to its maximum length ❶.



2. LATCH storage should look like this when complete ❷.

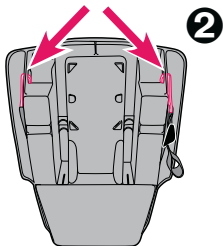
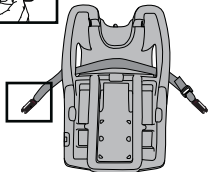

8.3 Cleaning and Maintenance

TO CLEAN SEAT PAD:

1. Unfasten hook and loop patches and plastic flaps from infant restraint.
2. Pull out plastic flaps from under infant restraint lip ❶ and ❷.
3. Unfasten hook and loop tape in seat area of pad and pull out from around harness hip straps.
4. Refer to your care tag on your seat pad for washing instructions. NO BLEACH.

Reverse steps to reinstall seat pad. Check that harness system is not twisted, and pull on harness system to be sure harness is securely reinstalled.

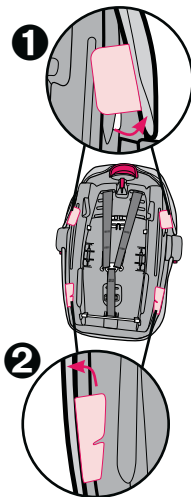

- **INFANT RESTRAINT METAL AND PLASTIC PARTS** may be cleaned by wiping with a mild soap and water solution. **DO NOT USE BLEACH OR DETERGENT** which may weaken plastic parts.
- **HARNESS STRAPS** may be spot cleaned or replaced. **DO NOT IMMERSE THE HARNESS STRAPS IN WATER.** Doing so may weaken the harness straps. **NEVER** iron the harness straps.
- **IF HARNESS STRAPS** have cuts, fraying or become badly twisted, you **MUST** replace the straps.
- **DO NOT USE INFANT RESTRAINT** without seat pad.
- **CONTINUOUS USE OF INFANT RESTRAINT MAY CAUSE DAMAGE TO VEHICLE SEAT.** Use an infant restraint mat, towel or thin blanket to protect upholstery.

8.4 Buckle Cleaning Process

⚠ WARNING

Prevent serious injury or death:

- Buckle must be properly latched.
- Periodically inspect and clean buckle to remove objects or debris that could prevent latching.

1. Turn restraint over, push clip through crotch strap slot ❶.
2. To clean buckle - place in a cup of warm water and gently agitate the buckle, press the red button several times while in the water ❷. **DO NOT SUBMERGE THE HARNESS WEBBING. DO NOT USE SOAPS or LUBRICANTS. DO NOT use household detergents. Never lubricate buckle.**
3. Shake out excess water and allow to air dry, harness webbing should be dry before use ❸.
4. Repeat Step 2 and 3 as needed.
5. Re-attach buckle into the desired slot. Buckle should fasten with a “click”
Re-check harness for correct installation before use.

