

INSTALLATION INSTRUCTIONS

BRACKET	OVAL SIDE BAR <u>WIDESIDER</u> 4"	WHEEL TO WHEEL WIDESIDER 4"	RUNNING BOARD WIDESIDER 5" & 6"	APPLICATION	MODEL
6841265	64126	-	680087	FORD F-150 EXT. CAB.	04 - 11
	64150	-	680087	FORD F-150 CREW CAB.	04 - 08
	64151	-	680087	FORD F-150 CREW CAB.	09 - 11
	-	641249	-	FORD F-150 CREW CAB. 5.5'	09 - 11
	-	641126	-	FORD F-150 EXT. CAB. 6.5'	04 - 11
	-	-	-	FORD F-150 CREW CAB. 5.5'	04 - 08
	-	-	-	-	-

Parts List:

ITEM	QTY.	CODE	DESCRIPTION	TORQUE
1	3	391694BB	Brackets set (Front & Middle & Rear)	-
2	2	371980EA	3/8" bolt plate	30 Lb/Ft
KTE-391695 Hardware kit including:				
3	12	-	5/16" Square head bolt	11 Lb/t
4	12	-	5/16" Flat washer	-
5	12	-	5/16" Lock washer	-
6	12	-	5/16" Hex nut	11 Lb/t
7	6	-	3/8" Clip nut	-
8	6	-	3/8 x 1 1/4" Hex head bolt	30 Lb/Ft
9	6	-	3/8 x 1 1/4" Carriage head bolt	30 Lb/Ft
10	12	-	3/8" Flat washer	-
11	12	-	3/8" Lock washer	-
12	8	-	3/8" Hex nut	30 Lb/Ft
13	2	-	Gasket vinyl	-
NOTE: 64126(B-PS) / 64150(B-PS) / 64151(B-PS) / 641249(B-PS) / 641126(B-PS) INCLUDES:				
14	1	-	Oval side bar widesider 4"	-

Tools required not including:

DESCRIPTION	QTY
9/16" & 1/2" Hex socket	1
17mm Double hex socket (12 point) or 15mm Wrench	1
Ratchet	1
Ratchet extension	1

ILLUSTRATION 1

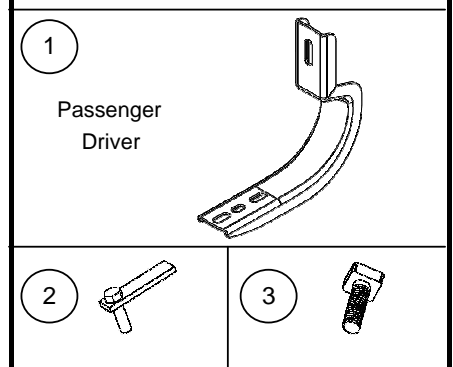

Approximated installation time: 30 min.

Instructions:

1. Before beginning the installation read all instructions thoroughly and verify that all hardware is accounted for. If there are any listed parts missing, please notify your distributor immediately.

ILLUSTRATION 2.

**Running board widesider 5" & 6" /
Oval Side Bar widesider 4"
NOT INCLUDED**

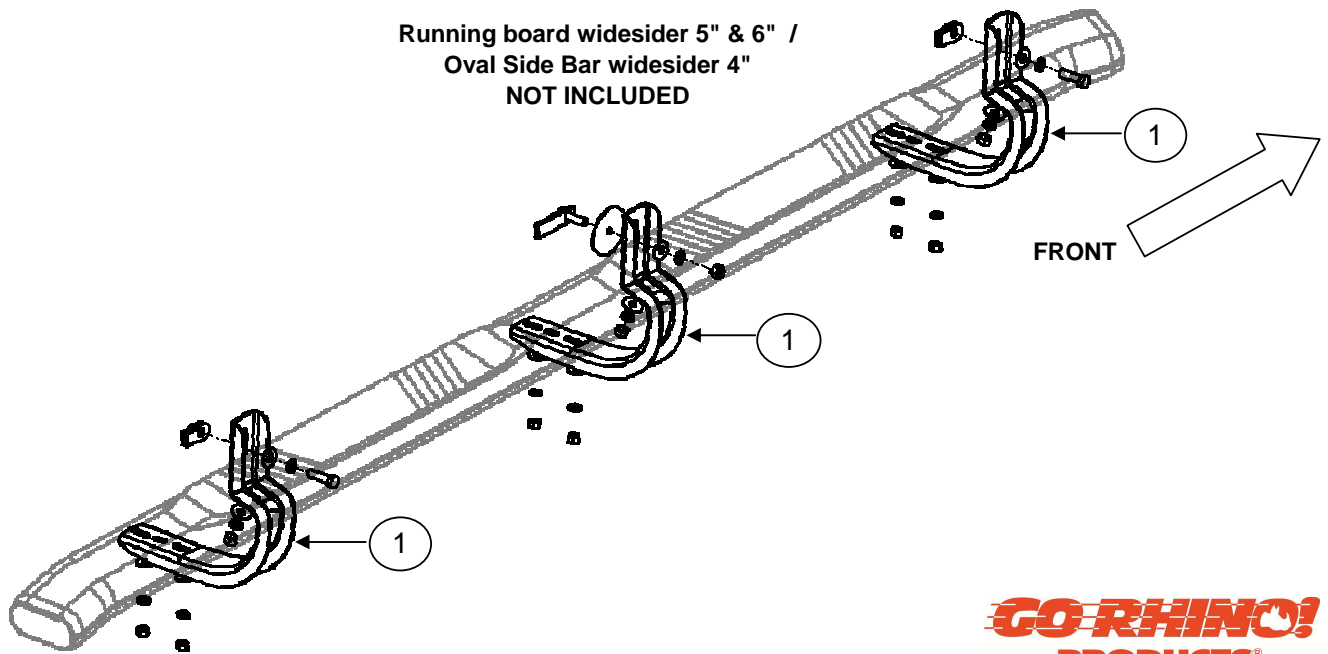

Illustration driver side.



Cleaning and care instructions:

Protect the finish with a non-abrasive automotive wax, (e.g. Pure Carnauba) on a regular basis. The use of any soap, polish, or wax that contains an abrasive is detrimental to the finish, as the compounds scratch the finish and cause corrosion.

Design:

Quality:

INSTALLATION INSTRUCTIONS

2. Located holes inside the body of vehicle, front, middle, rear, place a clip nut in upper part. Mount bracket and attach with: 3/8 x 1 1/4" hex head bolt, 3/8" flat and lock washers. **NOTE 1: Models 2009 - 2010 insert 3/8" bolt plate, gasket vinyl, middle part, attach with: 1 3/8" flat and lock washers, 3/8" hex nut.** In lower part by each bracket attach with: 3/8 x 1" carriage head bolt, 3/8" flat and lock washers, 3/8" hex nut. **SEE ILLUSTRATION 3 & 4.** Leave loose. Repeat in opposite side.

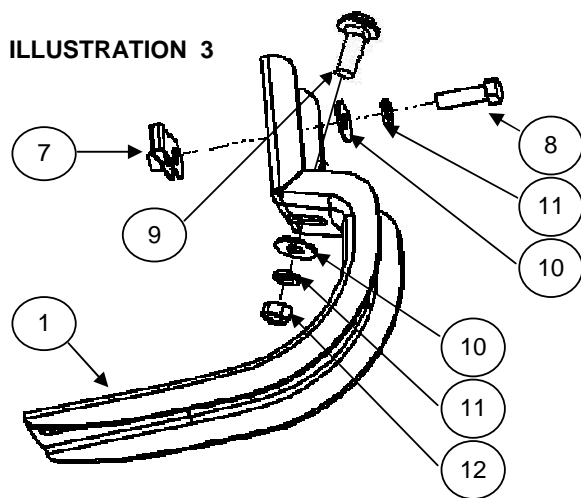

9/16" Use ratchet & socket.

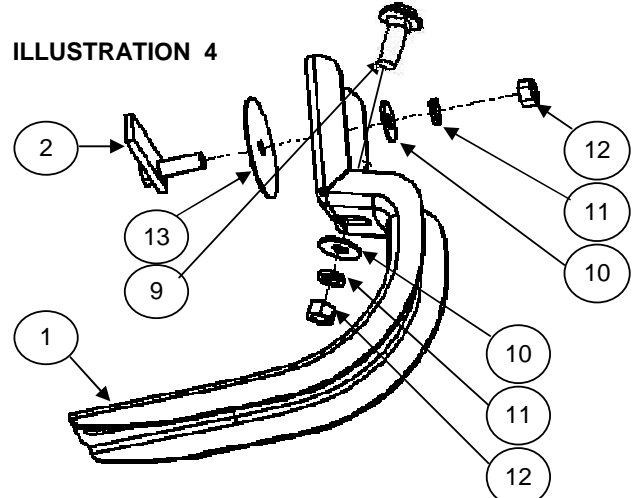

9/16" Use ratchet & socket.

In models 09 - 10 front and rear part. Driver side.
In models 04 - 10 front, middle and rear part. Driver side.

In models 09 - 10 middle part. Driver side.

3. If you acquired a Running board widesider 5" & 6", insert 5/16" square head bolt on rail, place on brackets and attach with: 5/16" Flat and lock washer, 5/16" hex nut. **SEE ILLUSTRATION 5.** Repeat for the opposite side. Leave loose.
4. If you acquired a Oval side bar widesider 4", place on brackets and attach with: 5/16" square head bolt, 5/16" Flat and lock washer. **SEE ILLUSTRATION 6.** Repeat for the opposite side. Leave loose.
5. Align Running board widesider 5" & 6" or Oval side bar widesider 4" and then tighten all bolts.
6. Do not use abrasive substances to clean your product.
7. Periodically check your product because it may need a re-tighten of bolts.
8. Fill the warranty card and place it inside your vehicle's glove box.

ILLUSTRATION 5

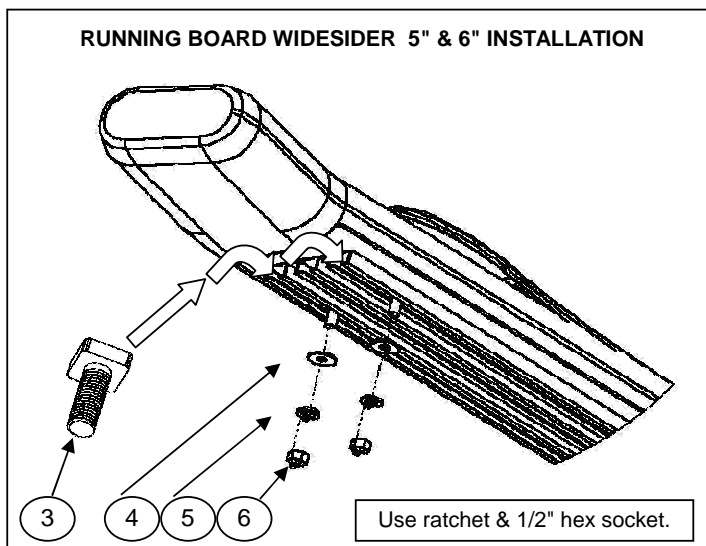
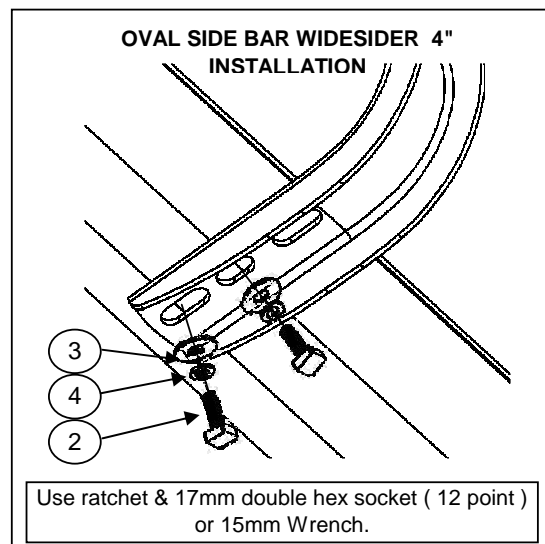

ILLUSTRATION 6



Cleaning and care instructions:

Protect the finish with a non-abrasive automotive wax, (e.g. Pure Carnauba) on a regular basis. The use of any soap, polish, or wax that contains an abrasive is detrimental to the finish, as the compounds scratch the finish and cause corrosion.

Design:

Quality:

INSTALATION INSTRUCTIONS

UNIVERSAL RUNNING BOARD

Parts List			
Item	QTY	Code	Description
1	1 set		Running Board
2	6 pcs	397872AA	U (clamp) bracket

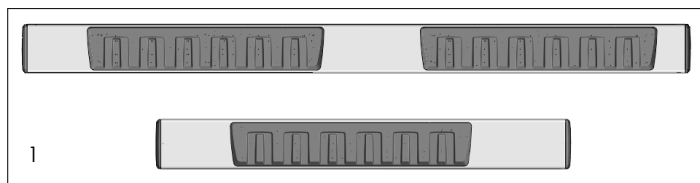

Required Tool:

- A. Ratchet w/5" extension
- B. 15mm wrench
- C. 17mm 12-point socket

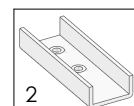

1. Before beginning the installation read all instructions thoroughly and verify that all hardware is accounted for. if there are any listed parts missing, please notify your distributor immediately.
2. To maintain and care this product keep it clean and do not use abrasive cleaners or polish waxes. It is recommended to use only non-abrasive automotive wax such as pure carnauba to avoid scratches and rust.
3. Once the main brackets are installed (**sold separately**), the approximate installation time is **15 min.**
4. Identify the outboard side of the running board prior to install. **See illustration 1.**
5. Place the U brackets inside the Running Board. Move them to align to the main brackets.
6. Place the flat and lock washers with the square head bolts. This hardware kit is included on the main brackets that are (**sold separately**). **See illustration 2.**
7. Align the Running board and tighten the bolts using the wrench or the socket.
8. **NOTE: For some regular cabs only two U brackets are needed per side.**

Illustration 1

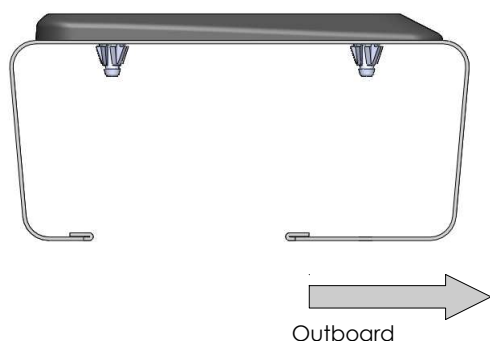

Illustration 2

