

Parts List

Item	Qty.	Code	Description	Max. Torque
1 Kit BRK-392445 Hardware brackets kit				
1	2 Piece	3912440BA	Front bracket.	-
2	2 Piece	3912440AA	Rear bracket.	-
3	2 Piece	3912441AA	Auxiliary front bracket.	-
4	2 Piece	3912442AA	Auxiliary rear bracket.	-
5	4 Piece	370200AA	3/8" Bolt plate.	30 Lb.ft
6	2 Piece	3713312	5/16" Bolt plate.	20 Lb.ft
1 Kit KTE-392445 Hardware bolts kit				
7	8 Piece	-	5/16" Square head bolt. Zinc black	-
8	8 Piece	-	5/16" Flat washer. Zinc black	-
9	8 Piece	-	5/16" Lock washer. Zinc black	20 Lb.ft
10	2 Piece	-	5/16" Flat washer. Zinc plate	-
11	2 Piece	-	5/16" Lock washer. Zinc plate	-
12	2 Piece	-	5/16" Hex nut. Zinc plate	20 Lb.ft
13	4 Piece	-	3/8 x 1 1/4" Carriage head bolt. Zinc black	30 Lb.ft
14	4 Piece	-	3/8" Flat washer. Zinc black	-
15	4 Piece	-	3/8" Lock washer. Zinc black	-
16	4 Piece	-	3/8" Hex nut. Zinc black	30 Lb.ft
17	4 Piece	-	3/8" Flat washer. Zinc plate	-
18	4 Piece	-	3/8" Lock washer. Zinc plate	-
19	4 Piece	-	3/8" Hex nut. Zinc plate	30 Lb.ft

WARNING:
THE FRONT BRACKET IS HEIGHTED THAN THE REAR BRACKET.

Required Tools (Not included)

Qty.	Description
1	9/16" Socket & Wrench
1	13mm Socket & Wrench
1	1/2" Socket & Wrench
1	Flat screw driver
1	Ratchet
1	Extension

Product Image

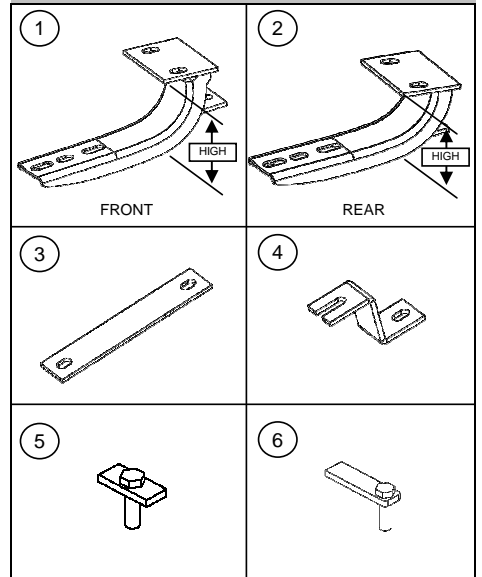

Instructions

- 1.- Before beginning the installation, please read all directions carefully and verify that all necessary hardware is accounted for. If any parts are missing, stop the installation and contact your distributor immediately.
- 2.- To maintain and care this product keep it clean and do not use abrasive cleaners or polish waxes. We recommend to use only non-abrasive automotive wax such as pure carnauba to avoid scratches and rust.
- 3.- The approximate installation time is 45 min.
- 4.- Locate and remove in the rocker panel the holes covered with plastic caps, use a flat screwdriver to remove them. Identify the locations of the holes referred in **PICTURE 1, 2.**

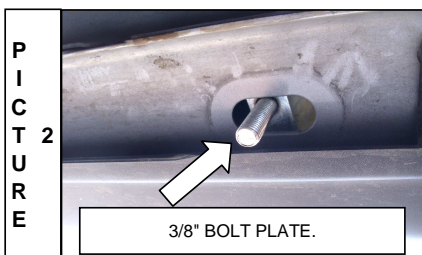
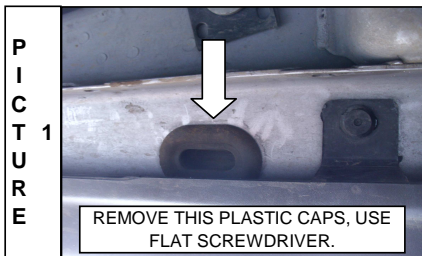

PICTURE 3.

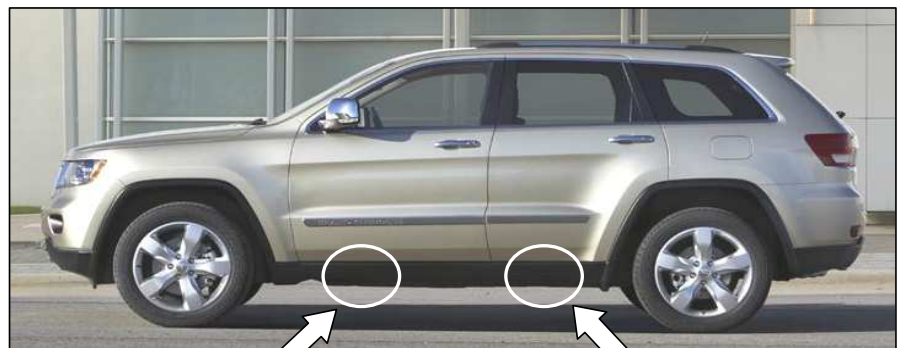

Under this part in the body install the front bracket, driver side shown.

Under this part in the body install the rear bracket, driver side shown.

5.- In the front hole, insert 3/8" bolt plate so that the surface is on the inside and the outside of the bolt body, **SEE PICTURES 1 AND 2.** Position the front bracket and attach with 3/8" flat and lock washer zinc plate, 3/8" hex nut zinc plate. Leave loose. **SEE ILLUSTRATION 1.**

NOTE: INSTALL REAR BRACKET IN THE SAME WAY.

ILLUSTRATION 1.

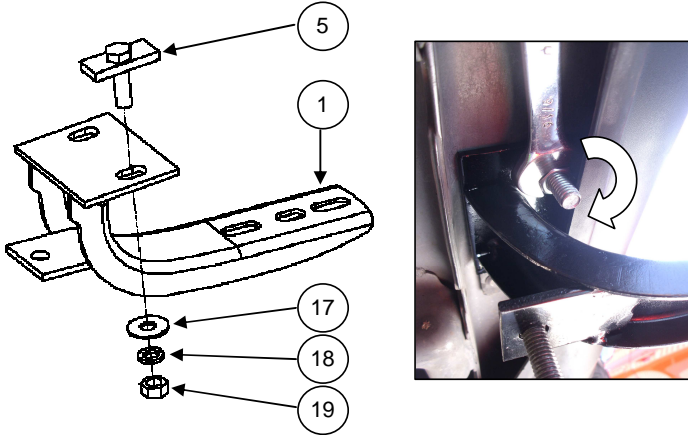

Use 9/16" wrench.

6.- Locate the hole in the chassis, Behind the front bracket and insert 5/16" bolt plate. **SEE PICTURE 4 AND 5.**

Place the front auxiliary bracket and secure with 5/16" flat and lock washer zinc plate, 5/16" hex nut zinc plate. Leave loose.

On the other side of the front auxiliary bracket, attach to the front bracket with 3/8 x 1 1/4" carriage head bolt zinc black, 3/8" flat and lock washer zinc black, 3/8" hex nut zinc black. Leave loose. **SEE ILLUSTRATION 2.**

PICTURE 4.

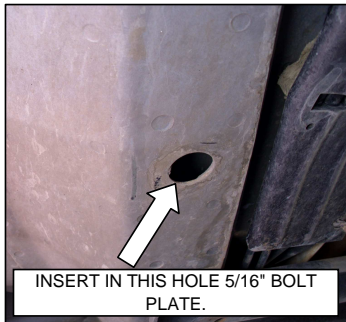

PICTURE 5.

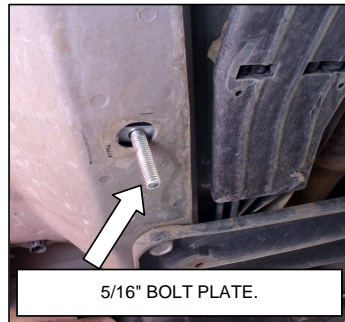
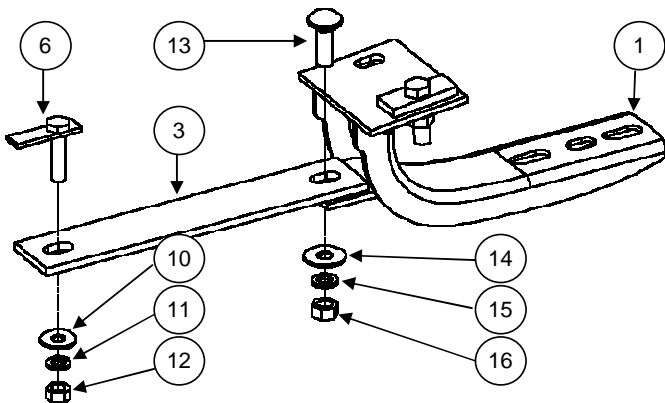

ILLUSTRATION 2.



Use 9/16" & 1/2" socket, ratchet and extension.

7.- Behind the rear bracket, locate the bolt OEM on the vehicle and loosen just enough to insert the rear auxiliary bracket. **SEE PICTURES A, B, C.** Leave loose.

PICTURES A, B, C.

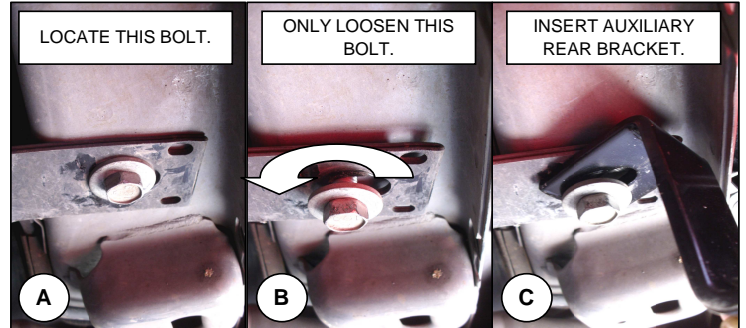

Use 13mm socket, ratchet and extension.

8.- Attach the rear auxiliary bracket to the rear bracket with 3/8 x 1 1/4" carriage head bolt zinc black, 3/8" flat and lock washer zinc black, 3/8" hex nut zinc black. Leave loose. **SEE ILLUSTRATION 3.**

ILLUSTRATION 3.

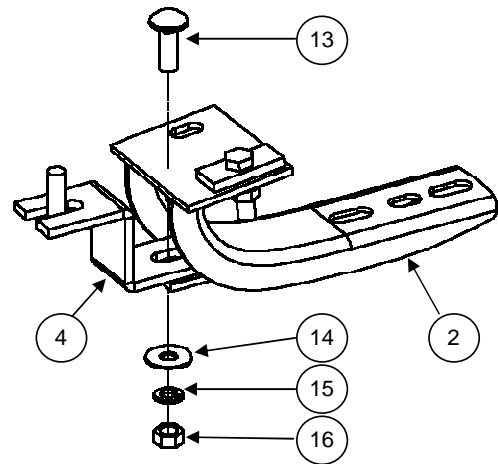

Use 9/16" socket, ratchet and extension.

9.- Make any final adjustments to the alignment of the bracket and tighten all bolts.

Repeat the above steps to install the passenger side.

10.- Periodically check your product because it may need a re-tighten of bolts.

INSTALLATION INSTRUCTIONS

UNIVERSAL RUNNING BOARD

Parts List				
Item	Qty.	Code	Description	Max. Torque
1	1 Set	-	Running Board	-
2	6 Pc.	396804AA	U (Clamp) Bracket *	-

* Wheel to Wheel Running Boards have the U (Clamp) Brackets included on the Bracket Kit (Sold Separately)

Required Tools (Not included)	
Qty.	Description
1	15mm Wrench
1	17mm Socket
1	Ratchet

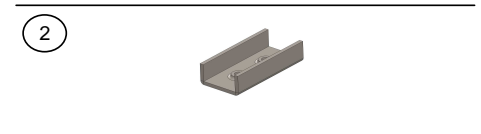
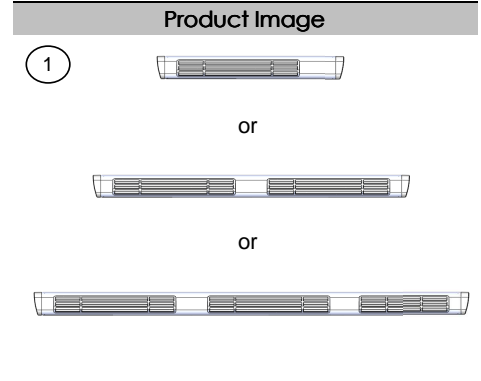

Instructions

1. Before beginning the installation, please read all directions carefully and verify that all necessary hardware is accounted for. If any parts are missing, stop the installation and contact your distributor immediately.
2. To maintain and care this product keep it clean and do not use abrasive cleaners or polish waxes. We recommend to use only non-abrasive automotive wax such as pure carnauba to avoid scratches and rust.
3. Once the main brackets are installed (**sold separately**), the approximate installation time is **15 min.**
4. Place the U brackets inside the Running Board. Move them to align to the main brackets. **See illustration 1.**
5. Place the flat and lock washers with the square head bolts. This hardware kit is included on the main brackets that are (**sold separately**). **See illustration 1.**
6. Align the Running board and tighten the bolts using a 1/2" wrench.
7. **NOTE: For some regular cabs only two U brackets are needed per side.**

ILLUSTRATION 1.

