

Installation Instructions

O.E. Xtreme Brackets Part # 6840435

2015 Chevrolet Silverado / GMC Sierra 2500HD, 3500HD Crew Cab (Diesel)

Parts List

Item	Qty.	Part #	Description	Torque
1	1 Pr	393014AA	Front Cab Bracket	-
2	1 Pr	393014BA	Middle Cab Bracket	-
3	1 Pr	393014CA	Rear Cab Bracket	-
4	1 Pr	393014DA	Front Auxiliary Bracket	-
5	1 Pr	391014FA	Middle Auxiliary Bracket	-
6	1 Pr	391014EA	Rear auxiliary bracket	-
7	6		5/16" Bolt Plate	
8	18		5/16" Flat Washer	-
9	18		5/16" Lock Washer	-
10	18		5/16" Hex Nut	11Ft. Lbs.
11	6		3/8" 1" Carriage Bolt	30 Ft. Lbs.
12	6		3/8" Flat Washer	-
13	6		3/8" Lock Washer	-
14	6		3/8" Hex Nut	30 Ft. Lbs.
15	2		1/2" Flat Washer	
16	12		5/16" Square Head Bolt	30 Ft. Lbs.
17	12		5/16" x 1" Hex Bolt	30 Ft. Lbs.

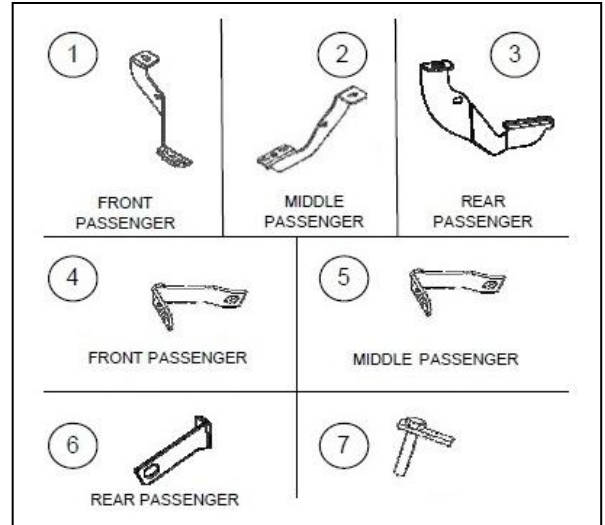

Tool Required:

- 1/2", 9/16", & 21mm Socket
- 17mm (12 point) Socket
- 15mm, 1/2" & 9/16" Wrench
- Ratchet & Ratchet Extension

Approximate Installation Time: 45 min

Read the installation instructions completely and verify that all of the parts listed are accounted for. If you have defective, missing or damaged parts or need assistance, please contact *Go Rhino Products* for fast, friendly customer service at: 1-888-427-4466 or email: warranty@gorrhino.com

WARNING! GM uses thread-locking compound on all factory body mount bolts. Removal using an air assisted impact or ratchet will damage the body mount bolt threads and the internal nut assembly.

We only recommend using hand tools to slowly remove and reinstall body mount bolts on all GM vehicles.

IMPORTANT! If during the body mount bolt removal process, it becomes increasingly difficult to unscrew the bolt with hand tools, tighten the bolt several rotations to clear the thread-locking compound from the threads, then reverse the direction and continue to unscrew the bolt until it is out. Repeat this process as necessary on all of the body mount bolts. Use of an appropriate anti-seize compound is highly recommended for re-installation. Tighten the body mount bolts to factory torque specifications.

Installation

Step-1 Begin the installation by removing the passenger side front body mount bolt, **(Photo 1)**. Keep all existing washers and bushing in place, and attach the passenger side front bracket to the vehicle using the factory body mount bolt. Leave the bolt loose for final adjustment, **(Photo 2 & Illustration 1)**.

Step-2 Locate the obround hole in the underside of the body and install one of the 5/16" bolt plates. **Photo #1** Attach the passenger side front auxiliary bracket to the body using the bolt plate, (1) 5/16" flat washer, (1) 5/16" lock washer and (1) 5/16" hex nut. Attach the opposite end of the auxiliary bracket to the side of the front bracket using (1) 3/8" x 1" carriage bolt, (1) 3/8" flat washer, (1) 3/8" lock washer and (1) 3/8" hex nut. Leave the nuts and bolts loose for final adjustment, **Photo 2 & Illustration 1)**.

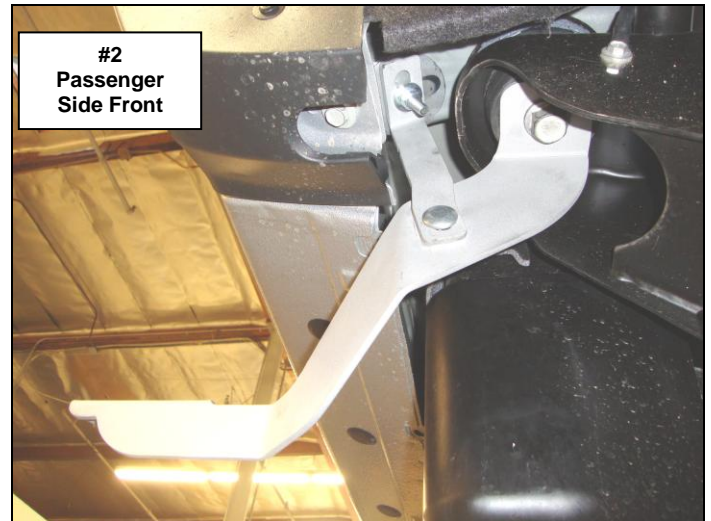
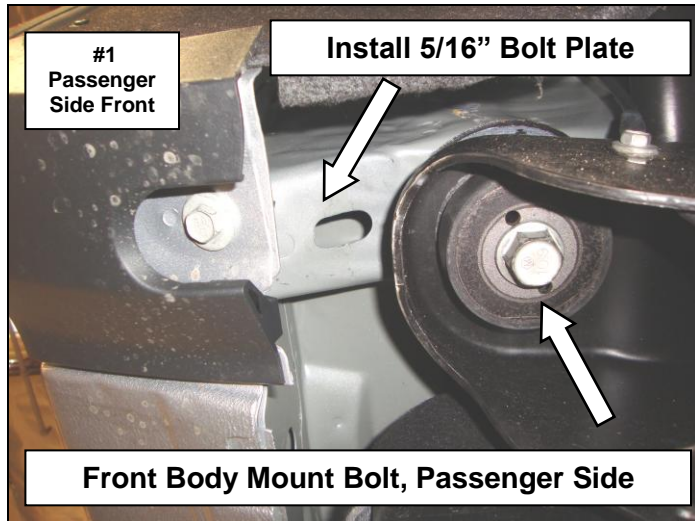
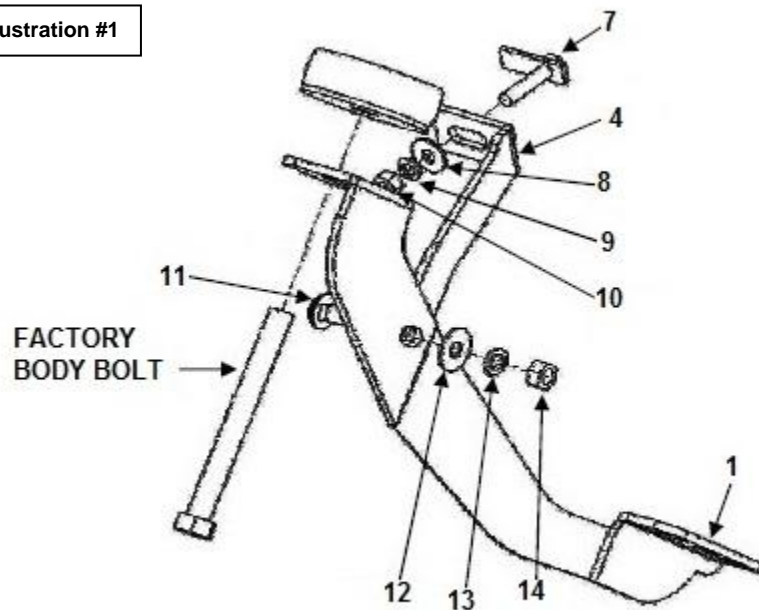

Illustration #1



Step-3 Remove the passenger side middle body mount bolt, **(Photo 3)**.

Keep all existing washers and bushing in place, and attach the passenger side middle bracket to the vehicle using the factory body mount bolt. Leave the bolt loose for final adjustment, **(Photo 4 & Illustration 2)**.

Step-4 Locate the obround hole in the underside of the body and install one of the 5/16" bolt plates, **(Photo 3)**.

Attach the passenger side middle auxiliary bracket to the body using the bolt plate, (1) 5/16" flat washer, (1) 5/16" lock washer and (1) 5/16" hex nut. Attach the opposite end of the auxiliary bracket to the side of the middle bracket using (1) 3/8" x 1" carriage bolt, (1) 3/8" flat washer, (1) 3/8" lock washer and (1) 3/8" hex nut. Leave the nuts and bolts loose for final adjustment, **(Photo 4 & Illustration 2)**.

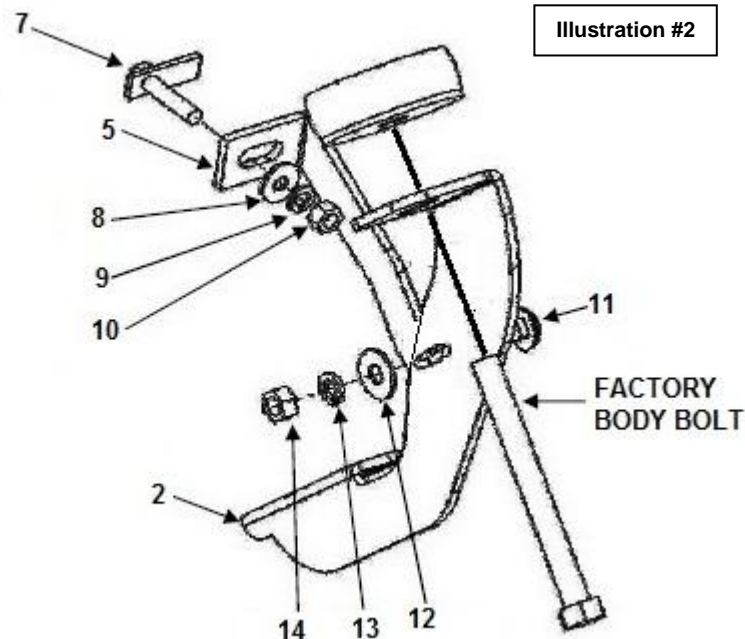
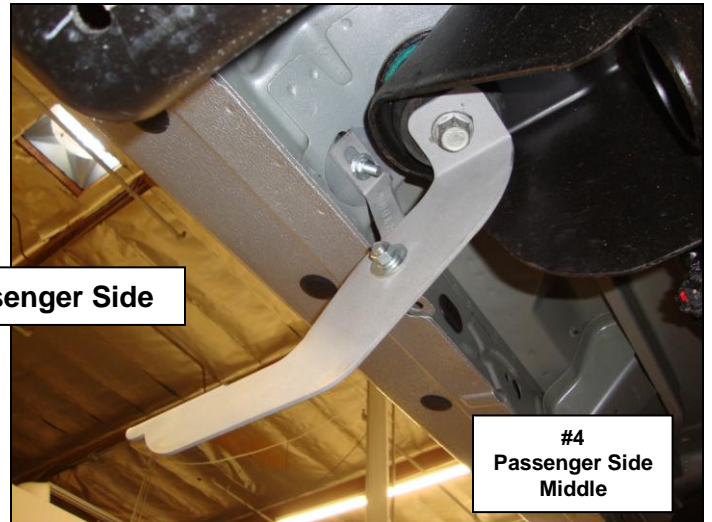
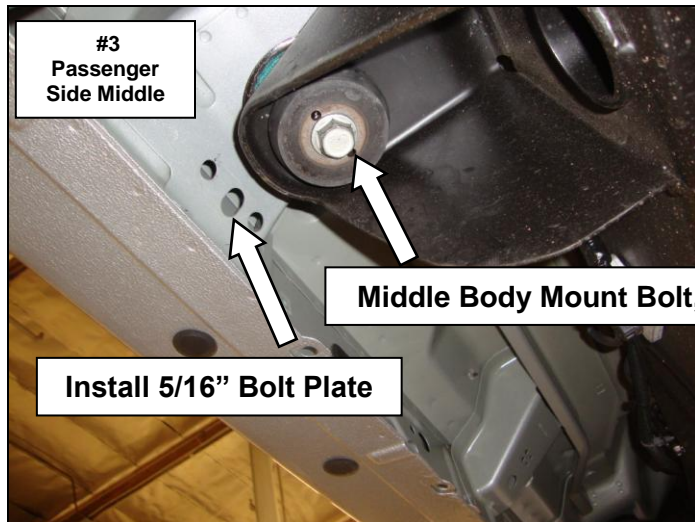

Step-5 Remove the passenger side rear body mount bolt, **(Photo 5)**.

Keep all existing washers and bushing in place, and attach the passenger side rear bracket to the vehicle using the factory body mount bolt and supplied 1/2" flat washer. Leave the bolt loose for final adjustment, **(Photo 6 & Illustration 3)**.

Step-6 Locate and remove the plastic plug in the body rocker panel to expose the round hole, and install one of the 5/16" bolt plates, **(Photo 5)**.

Attach the passenger side rear auxiliary bracket to the body rocker panel using the bolt plate, (1) 5/16" flat washer, (1) 5/16" lock washer and (1) 5/16" hex nut. Attach the opposite end of the auxiliary bracket to the side of the rear bracket using (1) 3/8" x 1" carriage bolt, (1) 3/8" flat washer, (1) 3/8" lock washer and (1) 3/8" hex nut. Leave the nuts and bolts loose for final adjustment, **(Photo 6 & Illustration 3)**.

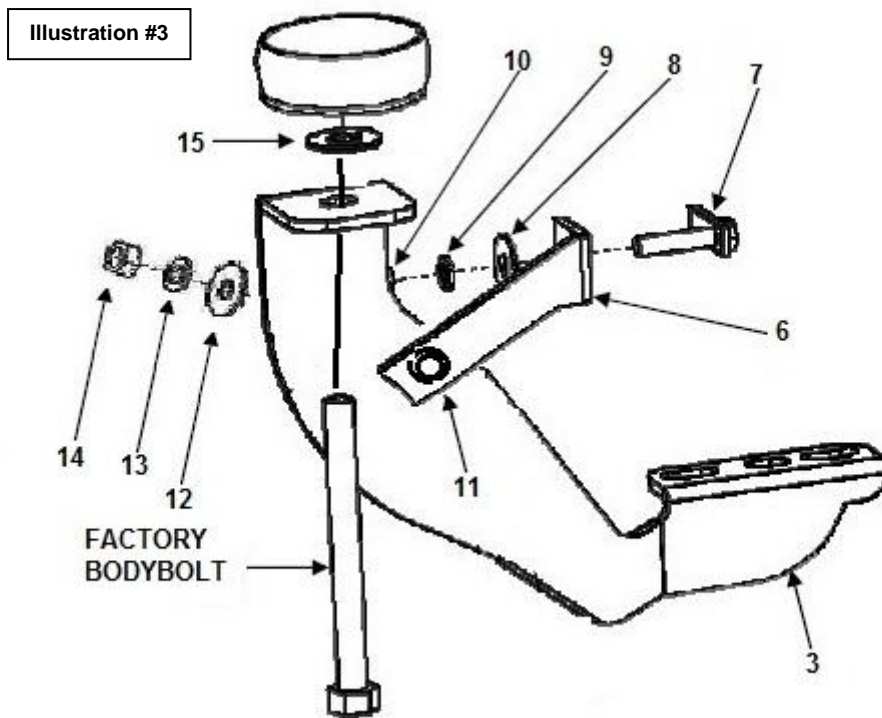
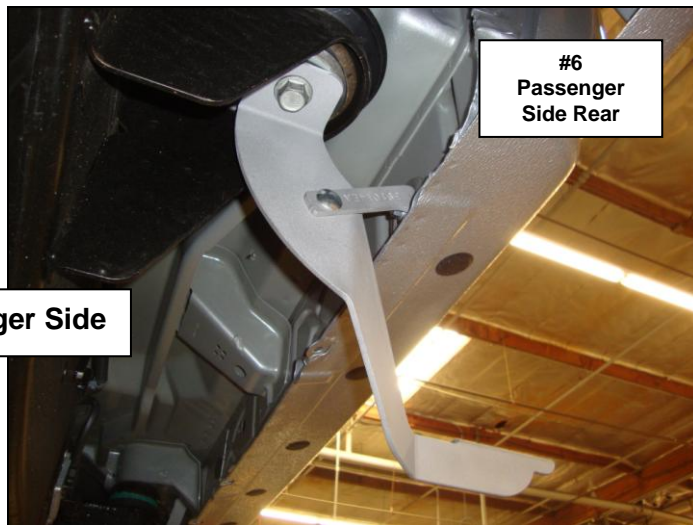
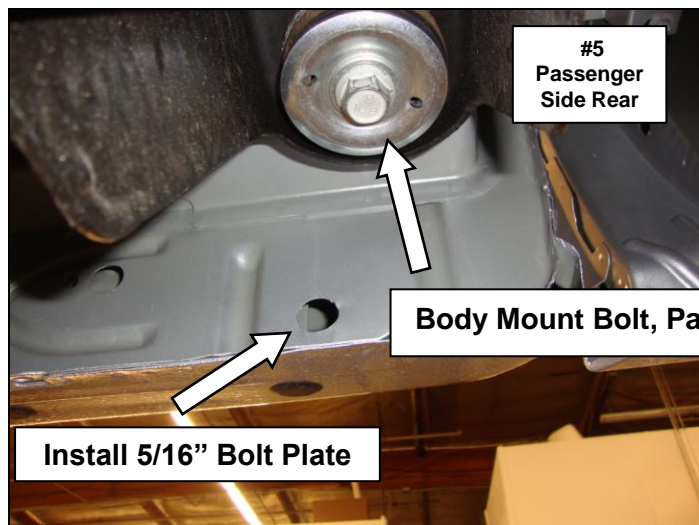

If installing **5" or 6" Composite** side bars, install (6) 5/16" square head bolts in the aluminum rail on the underside of the side bar and attach the side bar to each bracket using (2) 5/16" flat washers, (2) 5/16" lock washers and (2) 5/16" hex nuts, (**Photo 7**).

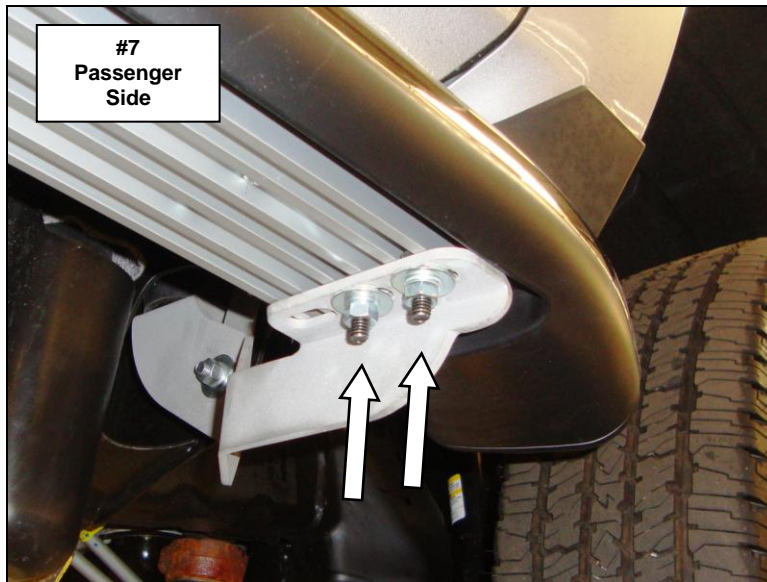

If installing **4", 5" or 6" Channel Mount** side bars attach the side bar to each bracket using (1) U-bracket (2) 5/16" hex bolts (2) 5/16" lock washers and (2) 5/16" flat washers, (**Photo 8**).

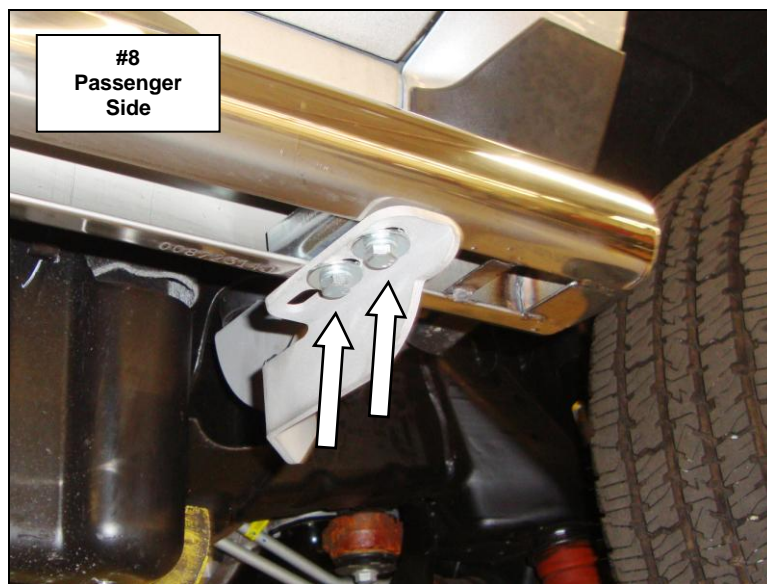

Step- 7 Align the side bar with the vehicle and tighten all side bar and bracket nuts and bolts.

Step -8 Repeat the installation steps to install the driver side brackets and side bar. Remember to check and retighten all nuts and bolts periodically.

INSTALLATION INSTRUCTIONS

UNIVERSAL RUNNING BOARD

Parts List				
Item	Qty.	Code	Description	Max. Torque
1	1 Set	-	Running Board	-
2	6 Pc.	396804AA	U (Clamp) Bracket *	-

* Wheel to Wheel Running Boards have the U (Clamp) Brackets included on the Bracket Kit (Sold Separately)

Required Tools (Not included)

Qty.	Description
1	15mm Wrench
1	17mm Socket
1	Ratchet

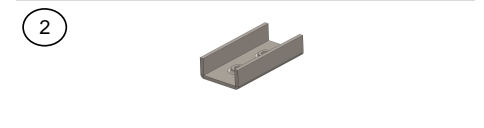
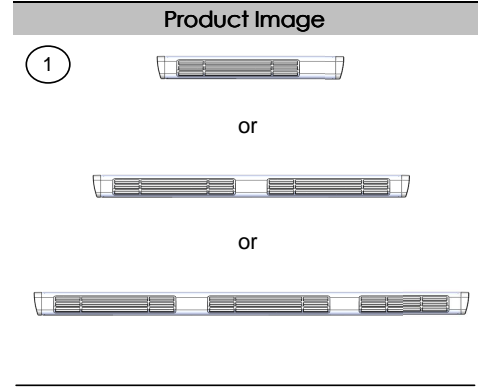

Instructions

1. Before beginning the installation, please read all directions carefully and verify that all necessary hardware is accounted for. If any parts are missing, stop the installation and contact your distributor immediately.
2. To maintain and care this product keep it clean and do not use abrasive cleaners or polish waxes. We recommend to use only non-abrasive automotive wax such as pure carnauba to avoid scratches and rust.
3. Once the main brackets are installed (**sold separately**), the approximate installation time is **15 min.**
4. Place the U brackets inside the Running Board. Move them to align to the main brackets. **See illustration 1.**
5. Place the flat and lock washers with the square head bolts. This hardware kit is included on the main brackets that are (**sold separately**). **See illustration 1.**
6. Align the Running board and tighten the bolts using a 1/2" wrench.
7. **NOTE: For some regular cabs only two U brackets are needed per side.**

ILLUSTRATION 1.

