

# Installation Instructions

4000 Series Side Steps  
Part Number 4047 (B-C-PS)

2014-2017 Chevrolet Silverado/GMC Sierra 1500 Crew Cab  
2015-2017 Chevrolet Silverado/GMC Sierra 2500HD & 3500HD Crew Cab

Parts List								
Item	Qty	Part No.	Description	Item	Qty	Part No.	Description	Torque
1	1	372020	Side Step Set	5	4		1/2" 2" Hex Bolt	65 Ft Lbs.
2	2	3710140	Front Bracket	6	10		1/2" Flat Washer	
3	2	372012AA	Rear Bracket	7	10		1/2" Lock Washer	
4	2	370772AA	Center Bracket	8	2		3/8" x 1 1/4" Hex Bolt	30 Ft Lbs.
				9	2		3/8" Flat Washer	
				10	2		3/8" Lock Washer	
				11	6		M12 x 120mm Hex Bolt	65 Ft Lbs.

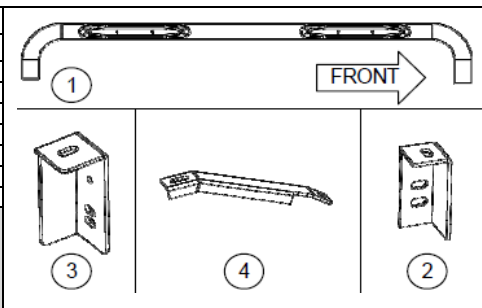

**Tools Required**  
9/16", 3/4", 18mm, 19mm & 21mm Sockets  
Ratchet & Ratchet Extension  
**Approximate Installation Time: 30 Min**

## IMPORTANT INSTALLATION NOTES AND SUGGESTIONS

The M12 x 120mm hex head Bolts and additional 1/2" flat and lock washers included, are part of a universal hardware kit and will not be used for installation on the 2014-2017 model years listed. Use the factory body mount bolts to attach the brackets (Refer to the illustration).

**WARNING!** GM uses thread-locking compound on all factory body mount bolts. Removal using an air assisted impact or ratchet will damage the body mount bolt threads and the internal nut assembly. We only recommend using hand tools to slowly remove and reinstall body mount bolts on all GM vehicles. If during the body mount bolt removal process, it becomes increasingly difficult to unscrew the bolt with hand tools, tighten the bolt several rotations to clear the thread-locking compound from the threads, then reverse the direction and continue to unscrew the bolt until it is out. Repeat this process as necessary on all of the body mount bolts. Use of an appropriate anti-seize compound is highly recommended for re-installation. Tighten the body mount bolts to factory torque specifications.

To maintain and care this product keep it clean and do not use abrasive cleaners or polish waxes. Texture Painted Finish: Mild liquid detergent may be used. Polished Stainless & Semi-Gloss Painted Finishes: We recommend using only non-abrasive automotive wax such as pure carnauba to avoid scratches and rust.

## INSTRUCTIONS

**Step-1** This set of side steps has a driver and passenger side. The longer leg on the side step goes to the front of vehicle.

**Step-2** Remove the body mount bolt (3 per side) and retain the washers and rubber bushings.

**Step-3** Install the front, center, and rear bracket with the washer and rubber bushing (as in the original position) using the factory body mount bolts or bolts provided. **Step-4** Attach the driver side, side step (Remember the longer leg goes to the front) to the front and rear brackets using (1) 1/2" x 2" hex head bolt, (1) 1/2" flat washer and (1) 1/2" lock washer for each bracket. Attach the center bracket to the side step using (1) 3/8 x 1 1/4" hex head bolt, (1) 3/8" lock washer and (1) 3/8" flat washer. Leave the bolts loose.

**Step-5** Align the side step and brackets with the vehicle then tighten all bolts. Repeat the installation steps to install the brackets and side step on the passenger side of the vehicle.

**Step-6** Check and re-tighten all bolts periodically.

## ILLUSTRATION

