

# GORRHINO®

## INSTALLATION INSTRUCTIONS

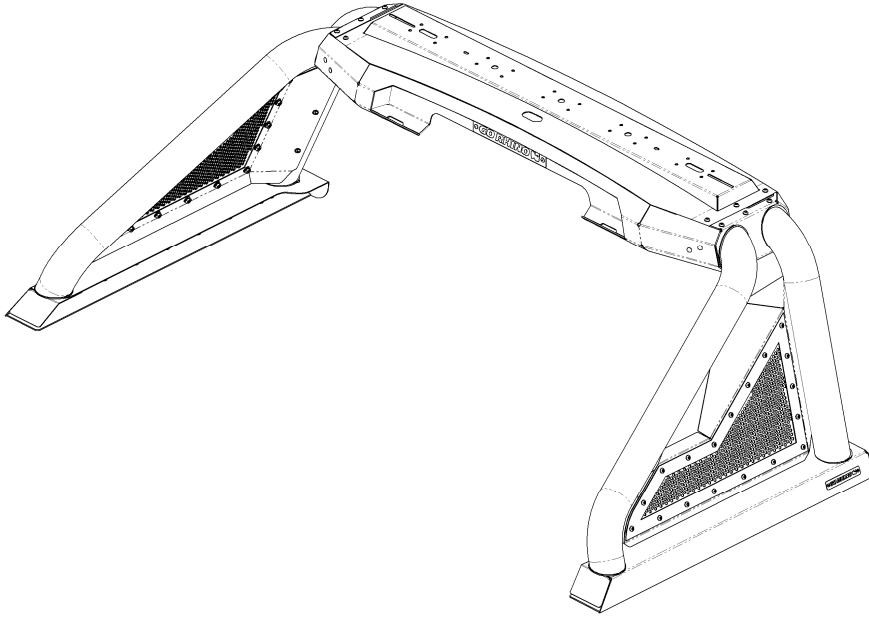

### PART NO.

- 911000T
- 911000PS
- 915000T
- 915000PS

### PRODUCT DESCRIPTION:

- Sport Bar 2.0, Full size Textured Black
- Sport Bar 2.0, Full size Polished Stainless Steel Tubes
- Sport Bar 2.0, Mid size Textured Black
- Sport Bar 2.0, Mid size Polished Stainless Steel Tubes

### PRODUCT SAFETY & LEGAL DISCLAIMER

- **IMPORTANT READ ALL INSTRUCTIONS CAREFULLY BEFORE INSTALLING, FAILURE TO DO SO MAY CAUSE PERSONAL INJURY OR DAMAGE TO PRODUCT AND/OR PROPERTY.**
- **Review the product package and contents prior to beginning the installation.** Take care when opening the packaging and removing items. If a return is needed you will want to return the product in its original packaging if possible.
- This instruction guide is provided as a GENERAL installation guide, some vehicles vary dimensionally and may require additional steps.
- Test fit the product on the vehicle prior to any third party modifications and or finishing. The manufacturer and/or distributors do not accept responsibility for third party charges, labor and or third part replacement modifications. Some modifications may void the factory warranty.
- Exercise due-diligence when installing this product. The manufacturer and distributors of this product do not accept any responsibility for vehicle damage or personal injury resulting from the installation of this product. Careless installation and operation can result in serious injury or equipment damage.
- This product is for general off-road use. All liability for installation and use rests with the owner/operator.
- **INSTALLER:** Once installation is complete, please return this guide along with other documentation included in this product back to the consumer for future reference. The manufacturer/distributors of this product do not guarantee this particular version will be available at a later date.



# INSTALLATION INSTRUCTIONS

## INJURY HAZARD

Please complete a shop and tool inspection prior to beginning the installation.

- Always make sure you have a clean, dry and well lit work area.
- Always remove jewelry, loose fitting clothing and wear protective gloves and eye protection.
- Always use extreme caution when jacking or raising a vehicle for work. Set the emergency brake and use tire/wheel blocks and jack stands. Refer to the vehicle manufacturer hand book. Utilize the vehicle manufacturers designated lifting points.
- Always use appropriate and adequate care in lifting parts during disassembly and installation. Seek help in lifting heavy or large items into place. Utilize jacks and or lifting devices when available.
- Always insure products are secure during disassembly and installation.
- Always wear eye protection and take steps to protect any exposed skin during the installations. Drilling, cutting and grinding plastic and metal may create flying particles that can cause injury.
- Always use extreme caution when drilling, cutting and or grinding on a vehicle. Thoroughly inspect the area to be drilled, on both sides of material, prior to modification and relocate any objects that may become damaged.
- Always assemble and tighten all fasteners per the installation instructions.
- Always route electrical cables carefully. Avoid moving parts, parts that may become hot and rough or sharp edges.
- Always insulate and protect all exposed wiring and electrical connections.

## MAINTENANCE AND CARE

- Always perform regular inspections and maintenance on mounts and related fasteners.
- Periodically check and tighten all fasteners.
- Stripped, fractured, or bent fasteners must be replaced.
- After washing the vehicle make sure to fully dry all surfaces.
- In areas with cold temperatures make sure to wash the product often to remove harmful materials used on road ways.
- Never use abrasive cleaners or polish compounds. Clean with a gentle soap and water. If you use wax use a non-abrasive automotive wax such as pure carnauba wax.

## WARNING

Some products have been designed to work together with factory rear sensor systems, factory forward facing sensor systems and factory air bags.

- Installation of some of these products may alter the factory sensor system performance.
- Factory sensors may read shackles or hooks protruding from the fairlead and or tow hooks.
- All sensor testing is completed by Go Rhino Products and or third party testing labs on modified vehicles.
- Sensor sensitivity, factory sensor housing, orientation, and operating conditions are all variables that will influence functionality of the sensors.
- Installation of some product may effect the factory air bag systems.
- Some products allow the use of third party products such as winches, shackles, hooks, etc. Follow the respective manufacturers operating instructions for use with our products.
- Make sure to fully understand the product, it's intended use and operation prior to use.
- Above all... be safe!

# GO RHINO®

## INSTALLATION INSTRUCTIONS

PARTS INCLUDED IN THIS LIST:

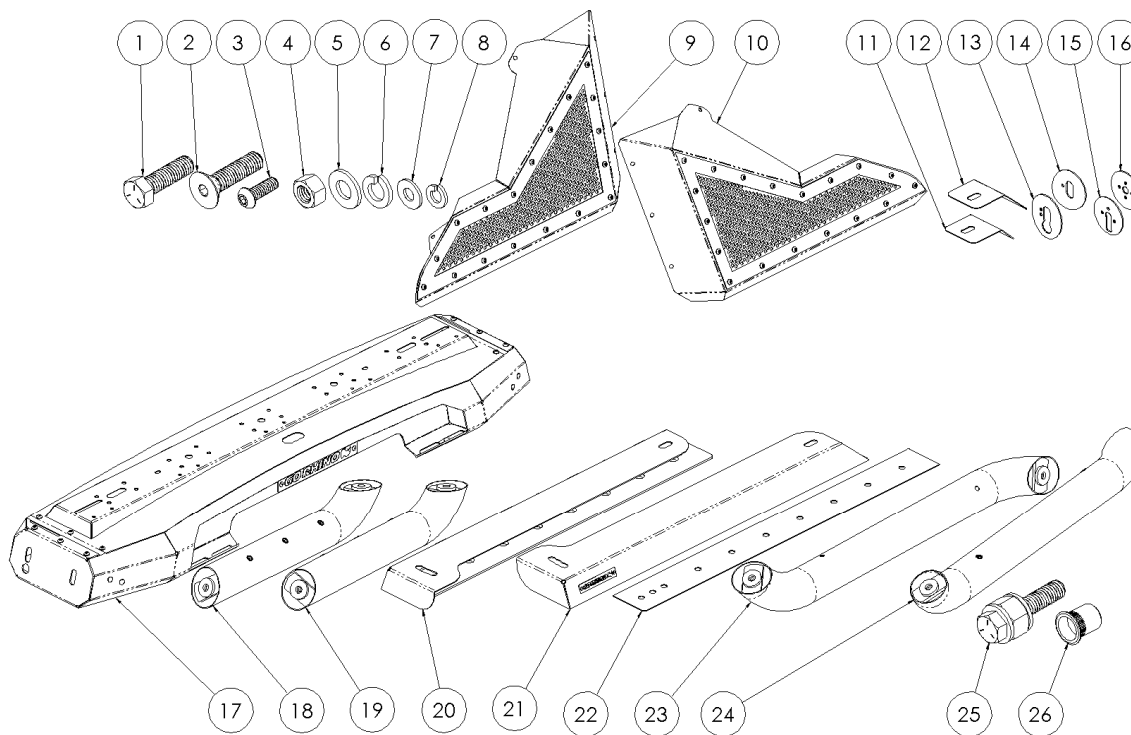

26	6	3/8" RIVET NUT
25	1	RIVET NUT INSTALL TOOL
24	1	DRIVER REAR TUBE
23	1	PASSENGER REAR TUBE
22	2	MOUNTING BASE SPACER
21	1	DRIVER MOUNTING BASE
20	1	PASSENGER MOUNTING BASE
19	1	DRIVER FRONT TUBE
18	1	PASSENGER FRONT TUBE
17	1	BOX ASSEMBLY
16	2	REAR BOTTOM TUBE SPACER
15	2	FRONT BOTTOM TUBE SPACER
14	2	REAR TOP TUBE SPACER
13	2	FRONT TOP TUBE SPACER
12	1	DRIVER COVER PLATE
11	1	PASSENGER COVER PLATE
10	1	DRIVER SIDE COVER
9	1	PASSENGER SIDE COVER
8	10	1/4" LOCK WASHER
7	10	1/4" FLAT WASHER
6	14	3/8" LOCK WASHER
5	14	3/8" FLAT WASHER
4	6	3/8" HEX NUT
3	10	1/4" x 3/4" BUTTON HEAD BOLT
2	6	3/8" x 1 1/4" FLAT HEAD BOLT
1	8	3/8" x 1 1/4" HEX HEAD BOLT
ITEM	QTY.	DESCRIPTION
<b>911000T / 911000PS</b>		
<b>915000T / 915000PS</b>		
<b>SPORT BAR 2.0</b>		

### TOOLS NEEDED FOR INSTALLATION:

- 5/32" Hex Driver
- 7/32" Hex Driver
- 9/16" and 3/4" Wrench
- Power drill
- 17/32" Drill bit

ESTIMATED TIME FOR INSTALLATION:

2 Hours

# GORRHINO®

## INSTALLATION INSTRUCTIONS

### STEP # 1

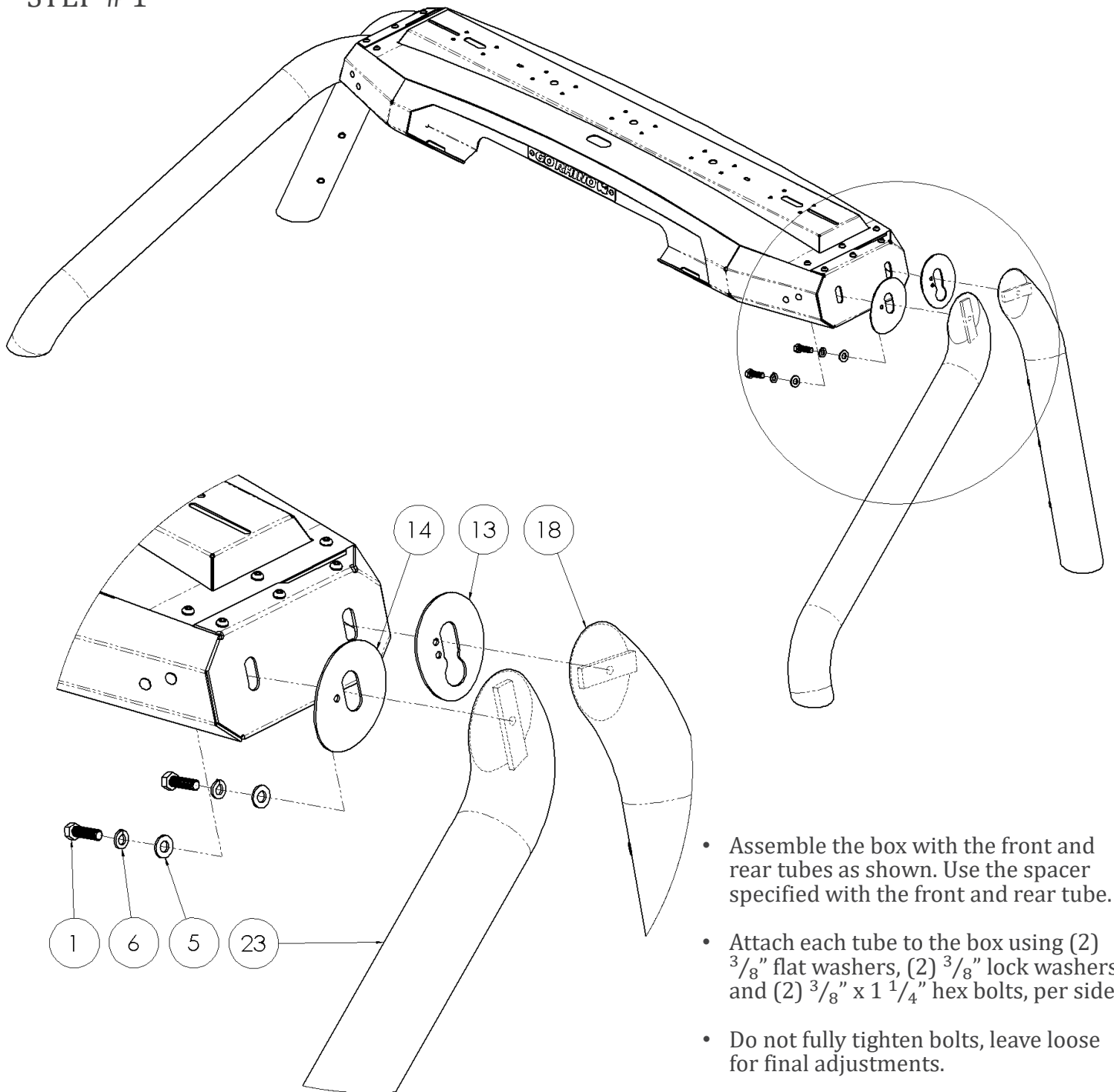

# GORRHINO®

## INSTALLATION INSTRUCTIONS

### STEP # 2

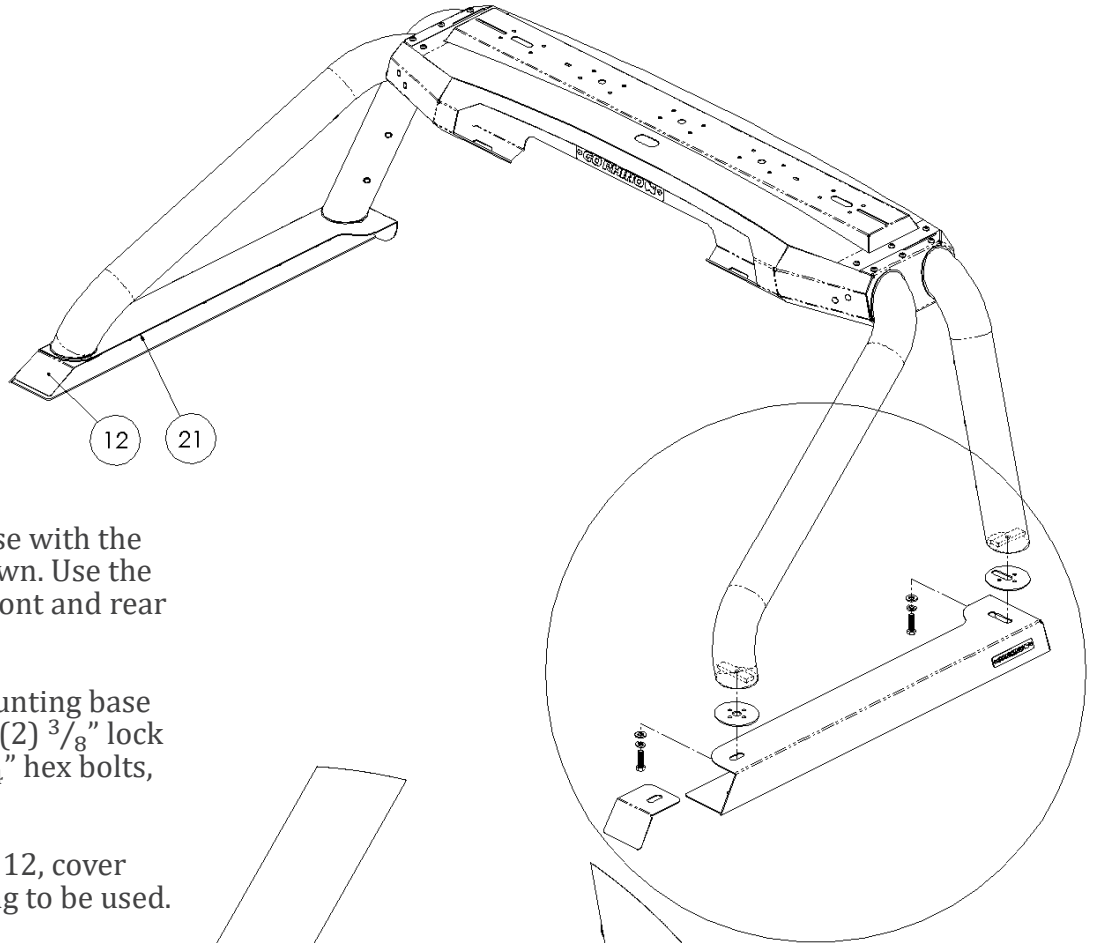

- Assemble the mounting base with the front and rear tubes as shown. Use the spacer specified with the front and rear tube.
- Attach each tube to the mounting base using (2)  $\frac{3}{8}$ " flat washers, (2)  $\frac{3}{8}$ " lock washers and (2)  $\frac{3}{8}$ " x  $1 \frac{1}{4}$ " hex bolts, per side.
- Do not install items 11 and 12, cover plates, if a bed cover is going to be used.
- Do not fully tighten bolts, leave loose for final adjustments.

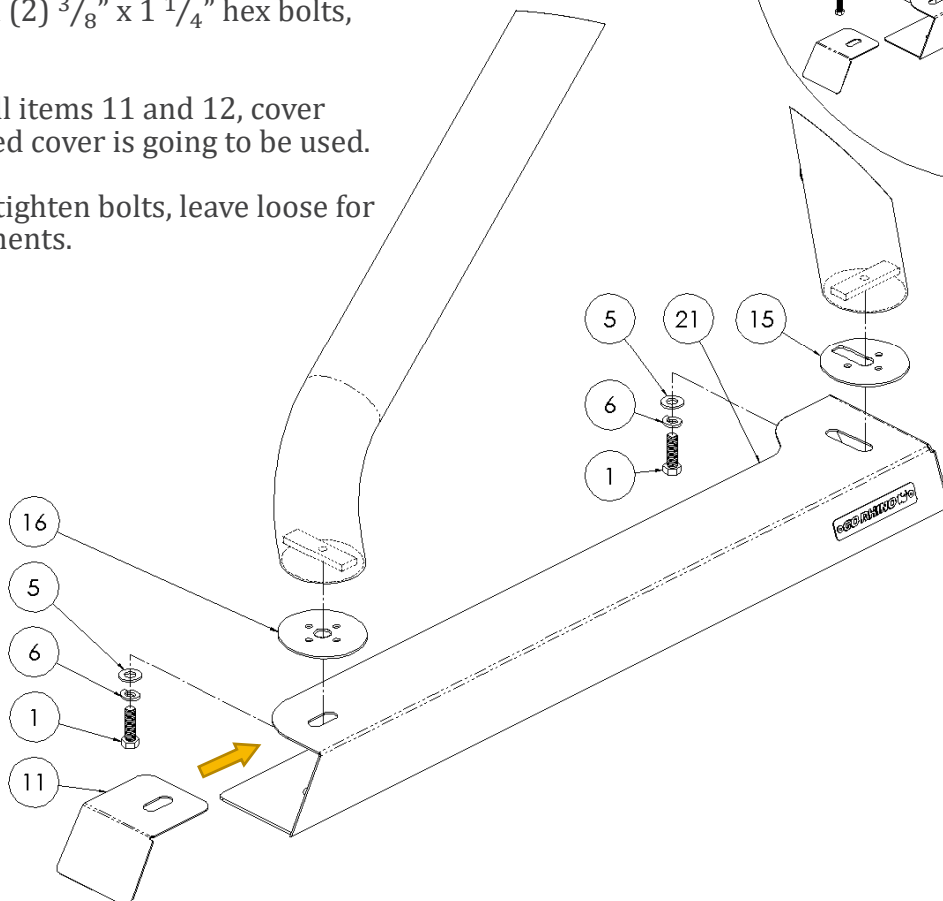

# GORRHINO®

## INSTALLATION INSTRUCTIONS

STEP # 3

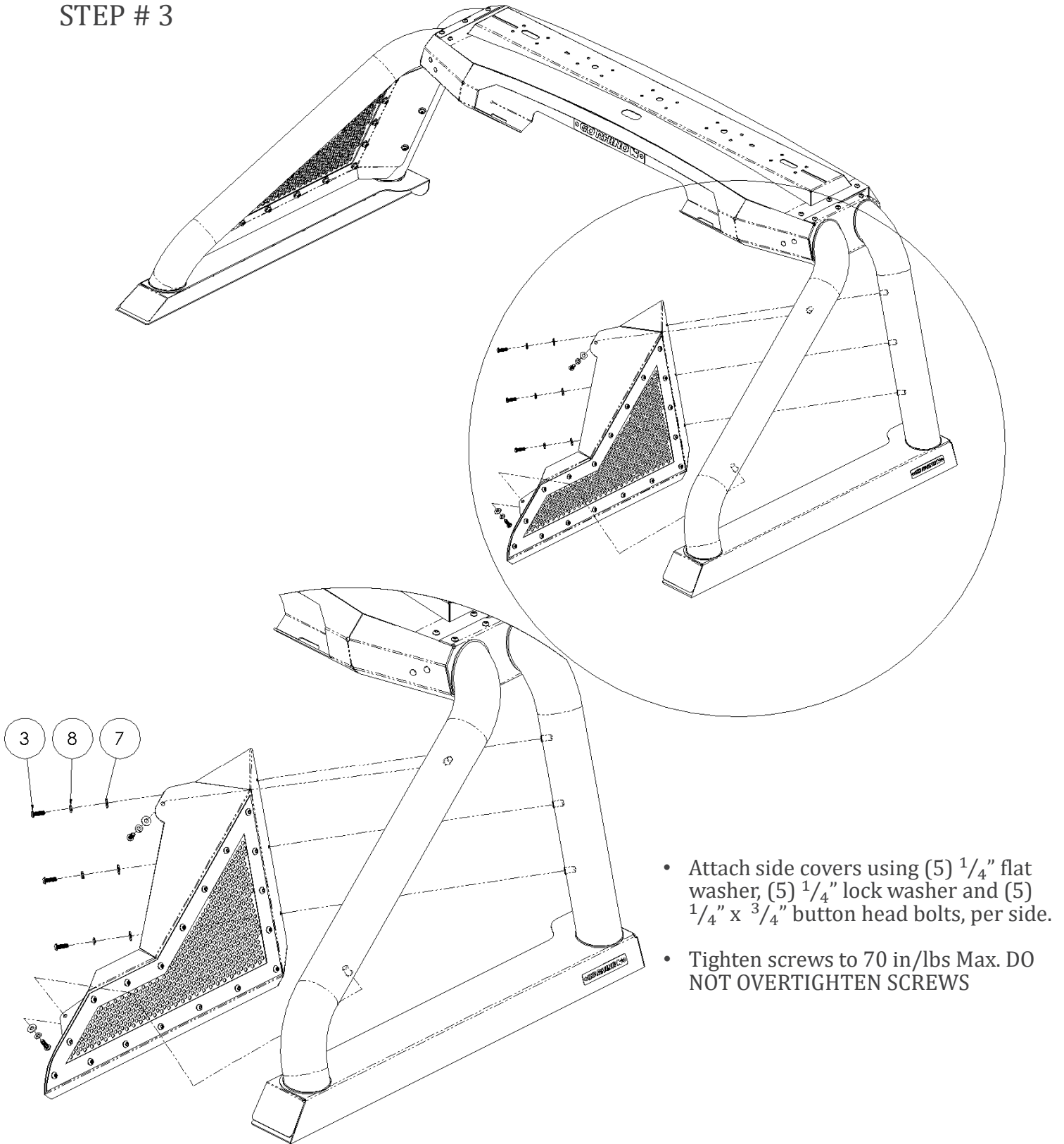

# GO RHINO®

## INSTALLATION INSTRUCTIONS

### STEP # 4

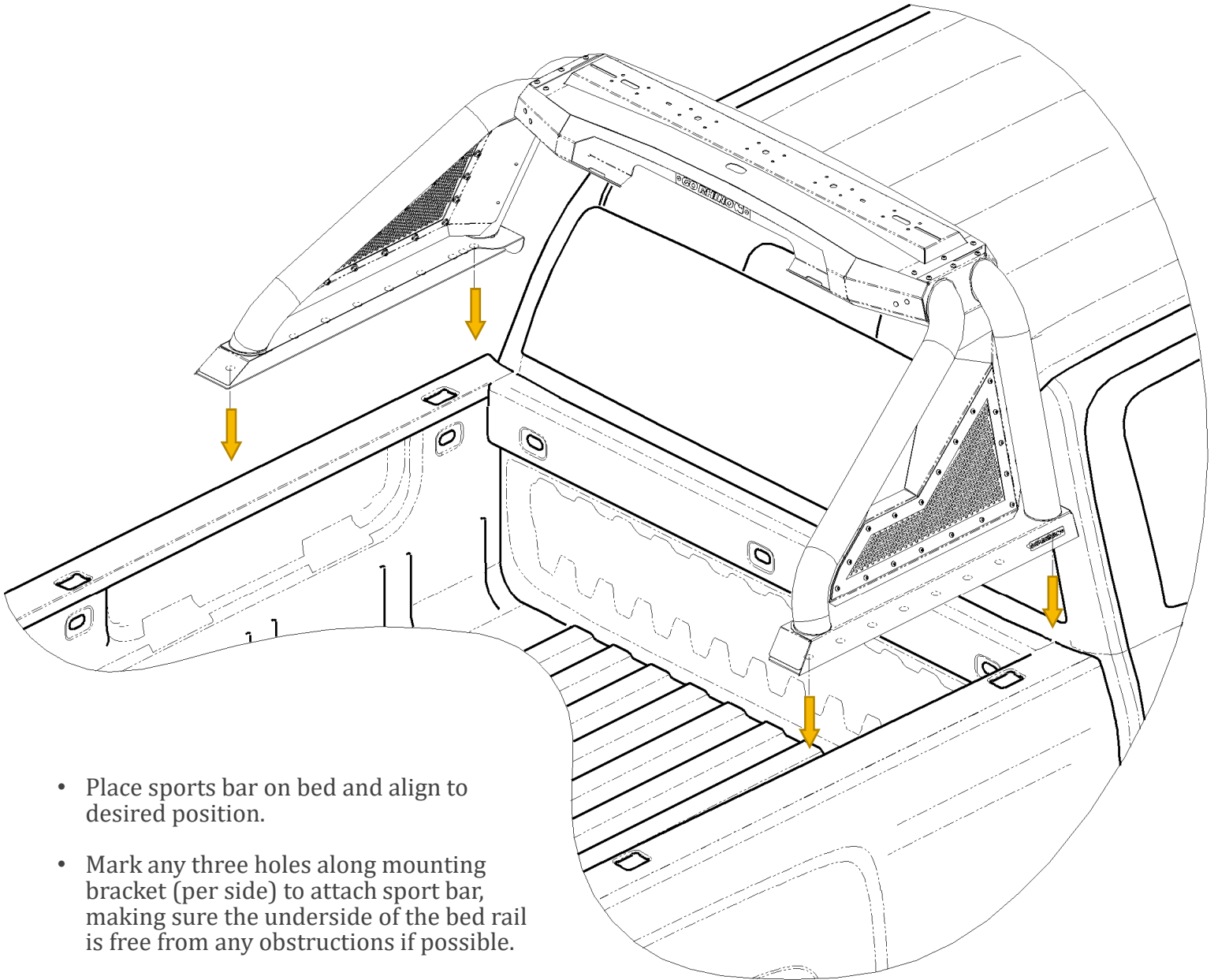

- Place sports bar on bed and align to desired position.
- Mark any three holes along mounting bracket (per side) to attach sport bar, making sure the underside of the bed rail is free from any obstructions if possible.
- Remove sport bar and drill 17/32" holes through bed rails.
- If holes can not be drill through top and bottom of bed rail proceed to step #4.1.

# GORRHINO®

## INSTALLATION INSTRUCTIONS

### STEP # 4.1

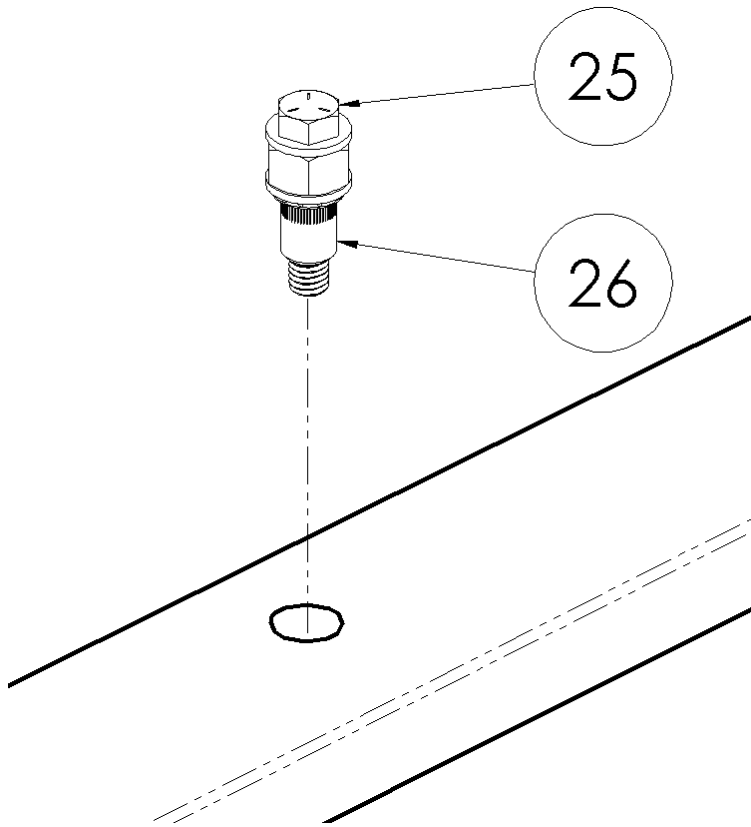

- Drill 17/32" holes through top side of bed rails.
- Apply automotive primer to any exposed metal.
- Hand tighten Rivet nut, Item 26 to Rivet Nut Install Tool, Item 25.
- Insert Rivet Nut into 17/32" hole.
- Hold spacer with 3/4" wrench.
- Tighten bolt with 9/16" wrench or socket and ratchet, this will compress the rivet nut.
- Once tight, unscrew the bolt and rivet nut will be installed.

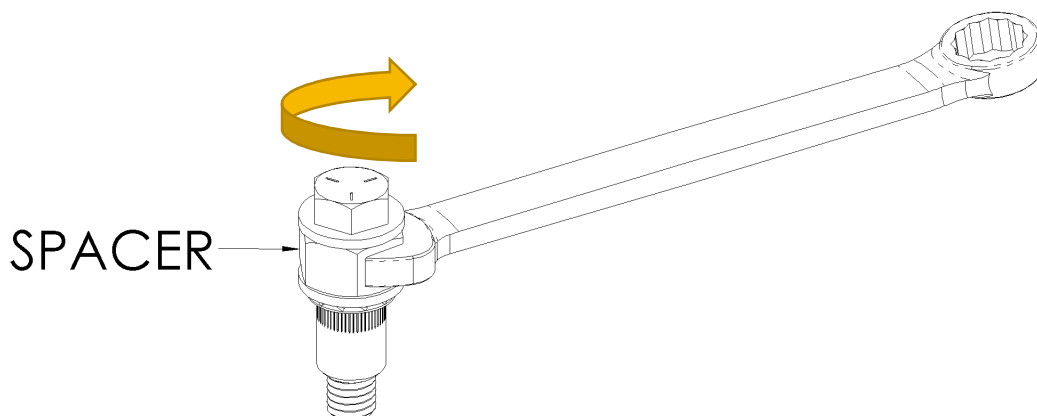



# GORRHINO®

## INSTALLATION INSTRUCTIONS

### STEP # 5

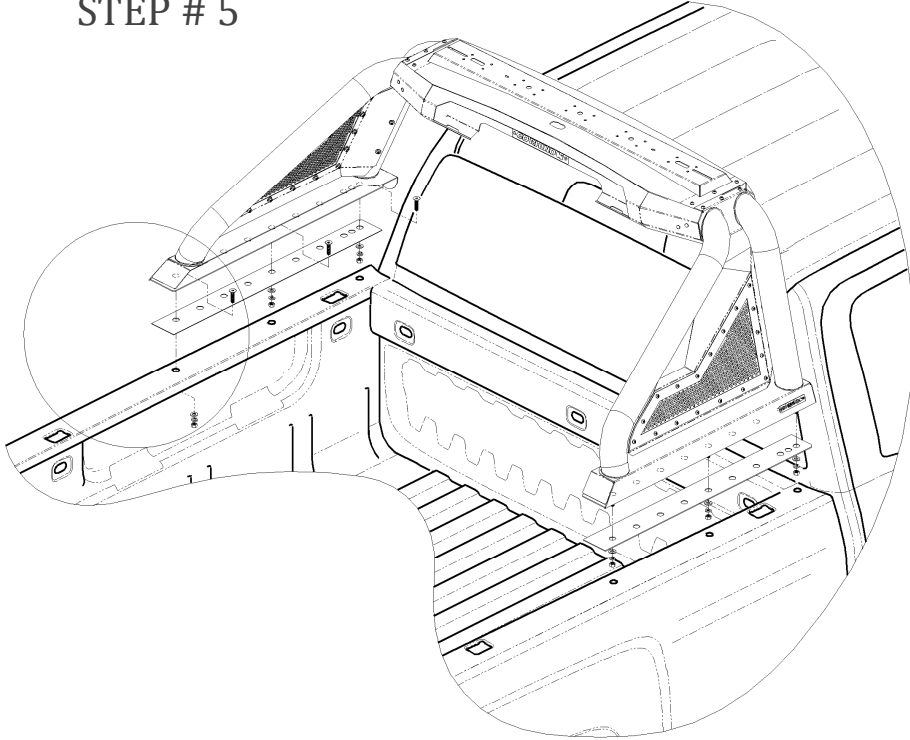

- Apply automotive primer to any exposed metal.
- Place the sport bar over drilled mounting holes using the mounting base spacer as shown, both sides.

- If hole was drilled through top and bottom, attach the sport bar using (3)  $\frac{3}{8}$ " flat washers, (3)  $\frac{3}{8}$ " lock washers and (3)  $\frac{3}{8}$ " x  $1\frac{1}{4}$ " flat head bolts, per side.

- If Rivet Nuts were installed, attach the sport bar using (3)  $\frac{3}{8}$ " x  $1\frac{1}{4}$ " flat head bolts, per side.

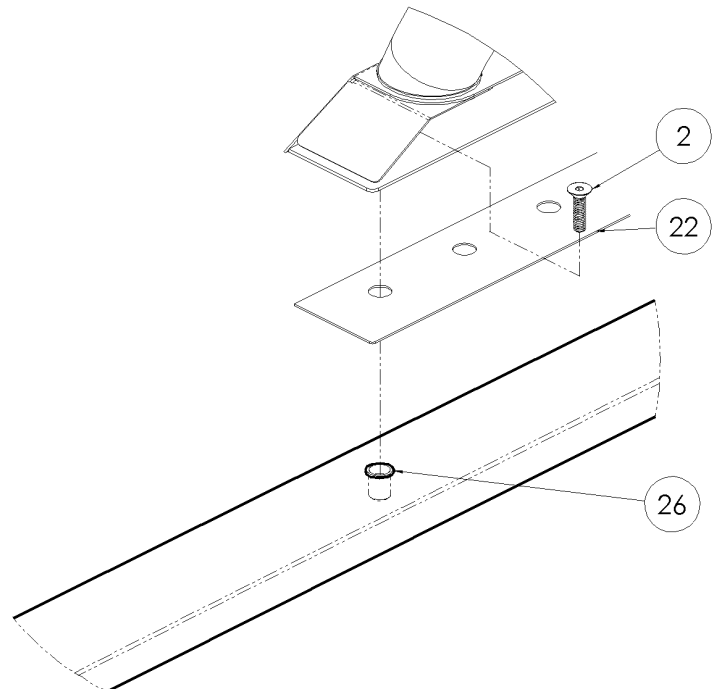
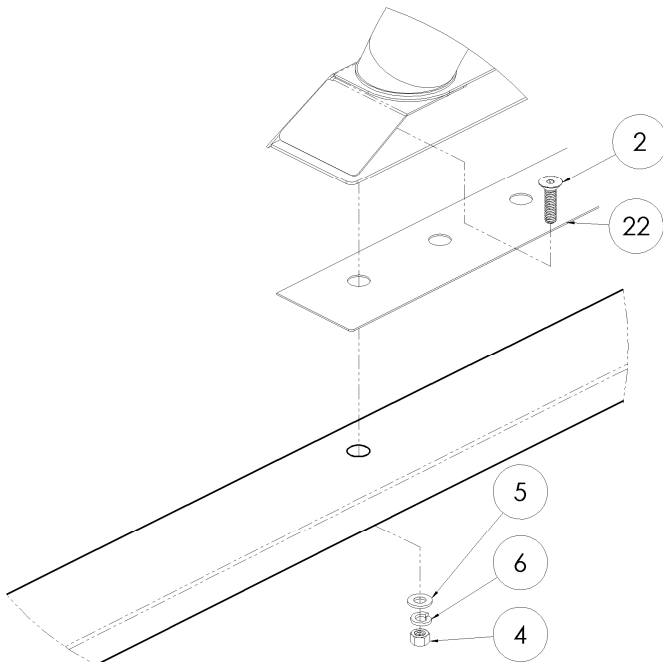

- Tighten all front and rear tube bolts to 26 ft/lbs Max. **DO NOT OVERTIGHTEN BOLTS**
  - Check and retighten all nuts and bolts periodically.

# GO RHINO®

## INSTALLATION INSTRUCTIONS

### PART NO.

- 960001T
- 960003T

### PRODUCT DESCRIPTION:

- Full size Powered Light Bar
- Mid size Powered Light Bar

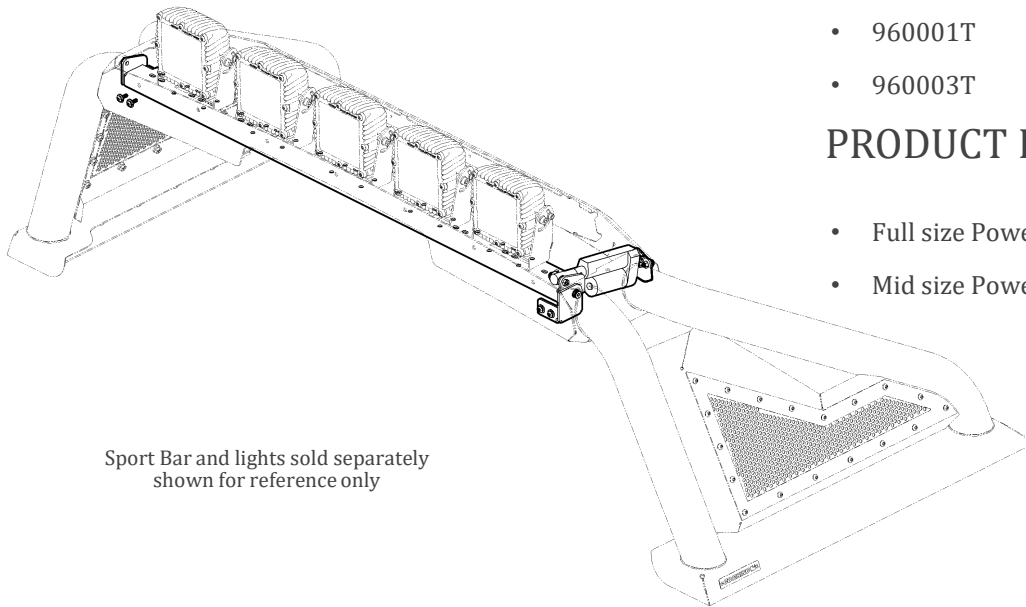

Sport Bar and lights sold separately  
shown for reference only

### PRODUCT SAFETY & LEGAL DISCLAIMER

- **IMPORTANT READ ALL INSTRUCTIONS CAREFULLY BEFORE INSTALLING, FAILURE TO DO SO MAY CAUSE PERSONAL INJURY OR DAMAGE TO PRODUCT AND/OR PROPERTY.**
- **Review the product package and contents prior to beginning the installation.** Take care when opening the packaging and removing items. If a return is needed you will want to return the product in its original packaging if possible.
- This instruction guide is provided as a GENERAL installation guide, some vehicles vary dimensionally and may require additional steps.
- Test fit the product on the vehicle prior to any third party modifications and or finishing. The manufacturer and/or distributors do not accept responsibility for third party charges, labor and or third part replacement modifications. Some modifications may void the factory warranty.
- Exercise due-diligence when installing this product. The manufacturer and distributors of this product do not accept any responsibility for vehicle damage or personal injury resulting from the installation of this product. Careless installation and operation can result in serious injury or equipment damage.
- This product is for general off-road use. All liability for installation and use rests with the owner/operator.
- **INSTALLER:** Once installation is complete, please return this guide along with other documentation included in this product back to the consumer for future reference. The manufacturer/distributors of this product do not guarantee this particular version will be available at a later date.



## INSTALLATION INSTRUCTIONS

### INJURY HAZARD

Please complete a shop and tool inspection prior to beginning the installation.

- Always make sure you have a clean, dry and well lit work area.
- Always remove jewelry, loose fitting clothing and wear protective gloves and eye protection.
- Always use extreme caution when jacking or raising a vehicle for work. Set the emergency brake and use tire/wheel blocks and jack stands. Refer to the vehicle manufacturer hand book. Utilize the vehicle manufacturers designated lifting points.
- Always use appropriate and adequate care in lifting parts during disassembly and installation. Seek help in lifting heavy or large items into place. Utilize jacks and or lifting devices when available.
- Always insure products are secure during disassembly and installation.
- Always wear eye protection and take steps to protect any exposed skin during the installations. Drilling, cutting and grinding plastic and metal may create flying particles that can cause injury.
- Always use extreme caution when drilling, cutting and or grinding on a vehicle. Thoroughly inspect the area to be drilled, on both sides of material, prior to modification and relocate any objects that may become damaged.
- Always assemble and tighten all fasteners per the installation instructions.
- Always route electrical cables carefully. Avoid moving parts, parts that may become hot and rough or sharp edges.
- Always insulate and protect all exposed wiring and electrical connections.

### MAINTENANCE AND CARE

- Always perform regular inspections and maintenance on mounts and related fasteners.
- Periodically check and tighten all fasteners.
- Stripped, fractured, or bent fasteners must be replaced.
- After washing the vehicle make sure to fully dry all surfaces.
- In areas with cold temperatures make sure to wash the product often to remove harmful materials used on road ways.
- Never use abrasive cleaners or polish compounds. Clean with a gentle soap and water. If you use wax use a non-abrasive automotive wax such as pure carnauba wax.

### WARNING

Some products have been designed to work together with factory rear sensor systems, factory forward facing sensor systems and factory air bags.

- Installation of some of these products may alter the factory sensor system performance.
- Factory sensors may read shackles or hooks protruding from the fairlead and or tow hooks.
- All sensor testing is completed by Go Rhino Products and or third party testing labs on modified vehicles.
- Sensor sensitivity, factory sensor housing, orientation, and operating conditions are all variables that will influence functionality of the sensors.
- Installation of some product may effect the factory air bag systems.
- Some products allow the use of third party products such as winches, shackles, hooks, etc. Follow the respective manufacturers operating instructions for use with our products.
- Make sure to fully understand the product, it's intended use and operation prior to use.
- Above all... be safe!

# GO RHINO®

## INSTALLATION INSTRUCTIONS

PARTS INCLUDED IN THIS LIST:

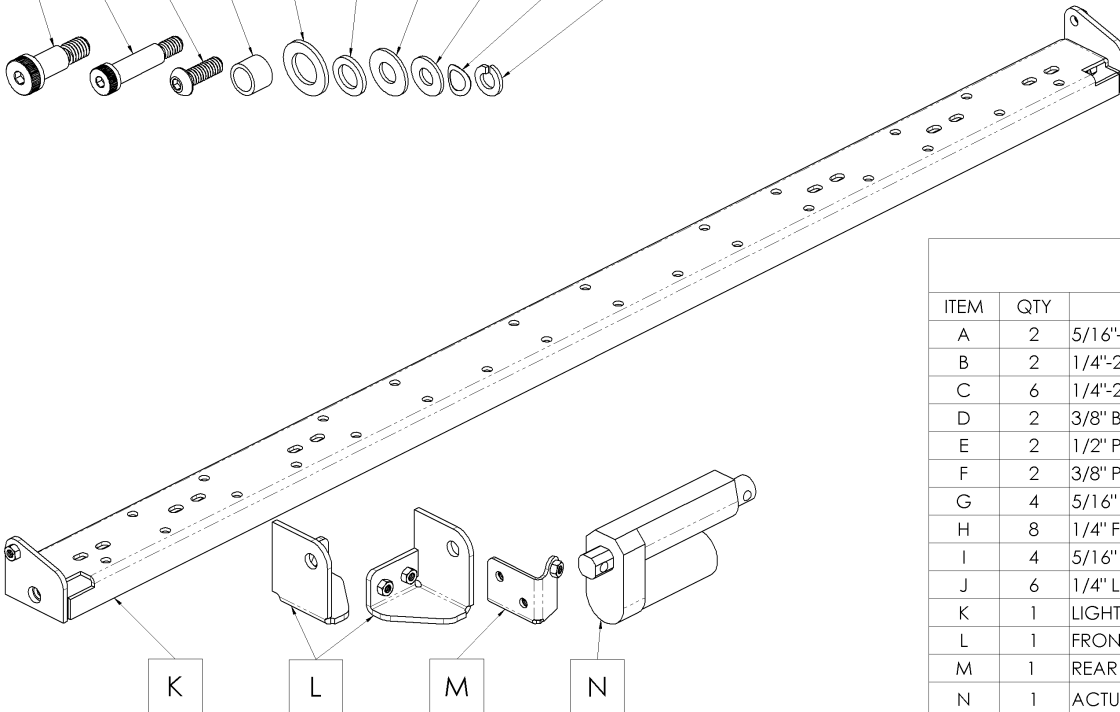
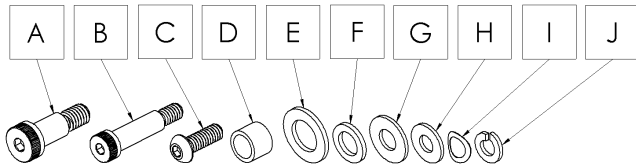

960001T SPORT BAR 2.0			
ITEM	QTY	DESCRIPTION	PART
A	2	5/16"-18 SHOULDER BOLT	
B	2	1/4"-20 SHOULDER BOLT	
C	6	1/4"-20 BUTTON HEAD SCREW	
D	2	3/8" BEARING SLEEVE	
E	2	1/2" PLASTIC WASHER	
F	2	3/8" PLASTIC WASHER	
G	4	5/16" FLAT WASHER	
H	8	1/4" FLAT WASHER	
I	4	5/16" DISC SPRING	
J	6	1/4" LOCK WASHER	
K	1	LIGHT MOUNT BAR	9600010CA
L	1	FRONT BRACKET SET	9600010BA
M	1	REAR BRACKET	9600010AA
N	1	ACTUATOR / SWITCH/ HARNESS	9600010DA

Go Rhino recommends you, the installer, read this installation instruction manual from front to back before installing the product.

### TOOLS NEEDED FOR INSTALLATION:

- 3/16" Hex Driver
- 5/32" Hex Driver

ESTIMATED TIME FOR INSTALLATION:

2 Hours

# GORRHINO<sup>®</sup>

## INSTALLATION INSTRUCTIONS

### STEP # 1

- Although a variety of lights were meant to fit on bar, some drilling may still be required.

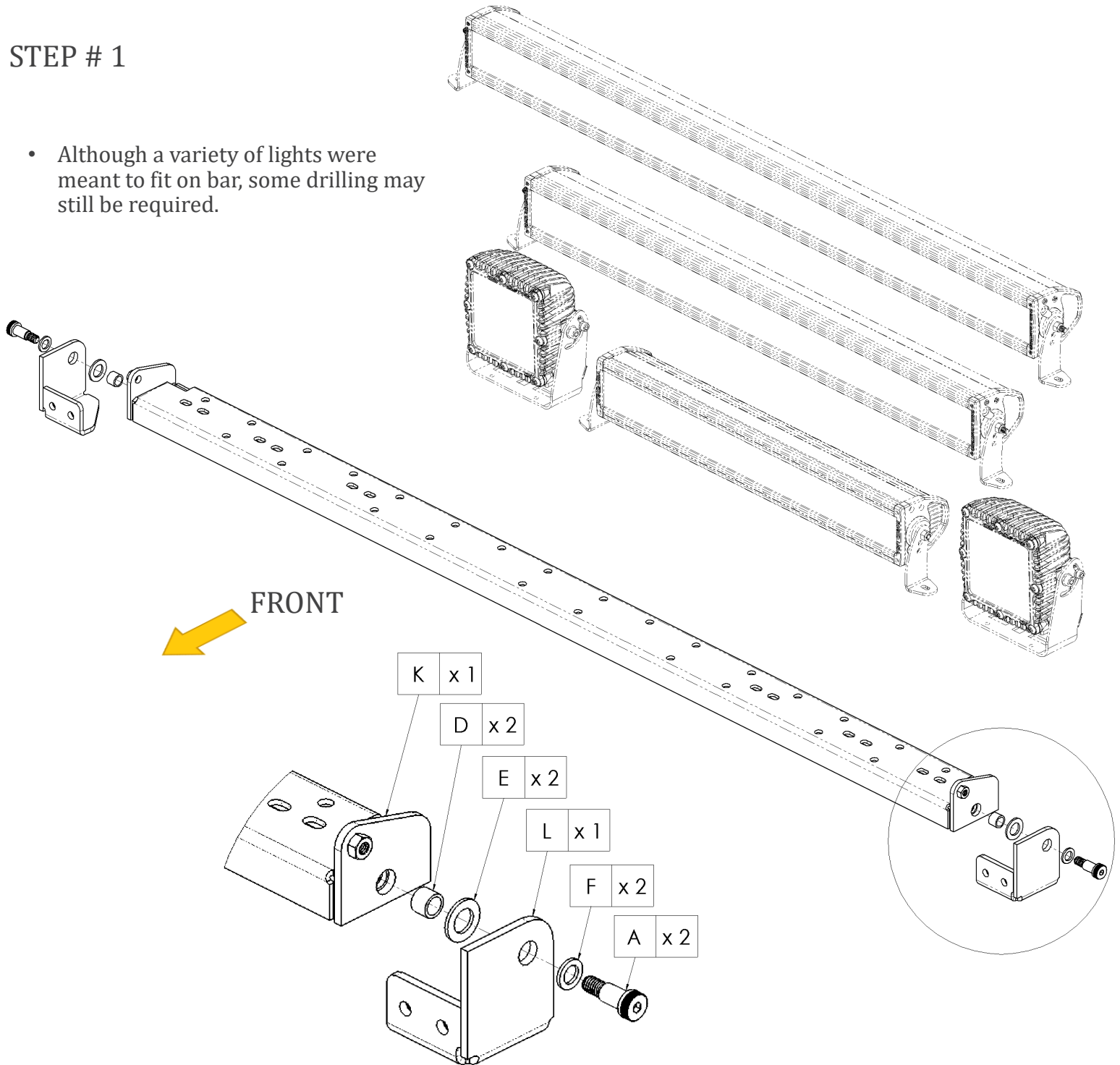

- Assemble light bar mount with front bracket set using (1)  $\frac{5}{16}$ "-18 shoulder bolt, (1)  $\frac{3}{8}$ " plastic washer, (1)  $\frac{1}{2}$ " plastic washer and (1)  $\frac{3}{8}$ " bearing sleeve per side.
- Tighten shoulder bolt to 125 in/lbs Max. DO NOT OVERTIGHTEN BOLT.

# GORRHINO<sup>®</sup>

## INSTALLATION INSTRUCTIONS

### STEP # 2

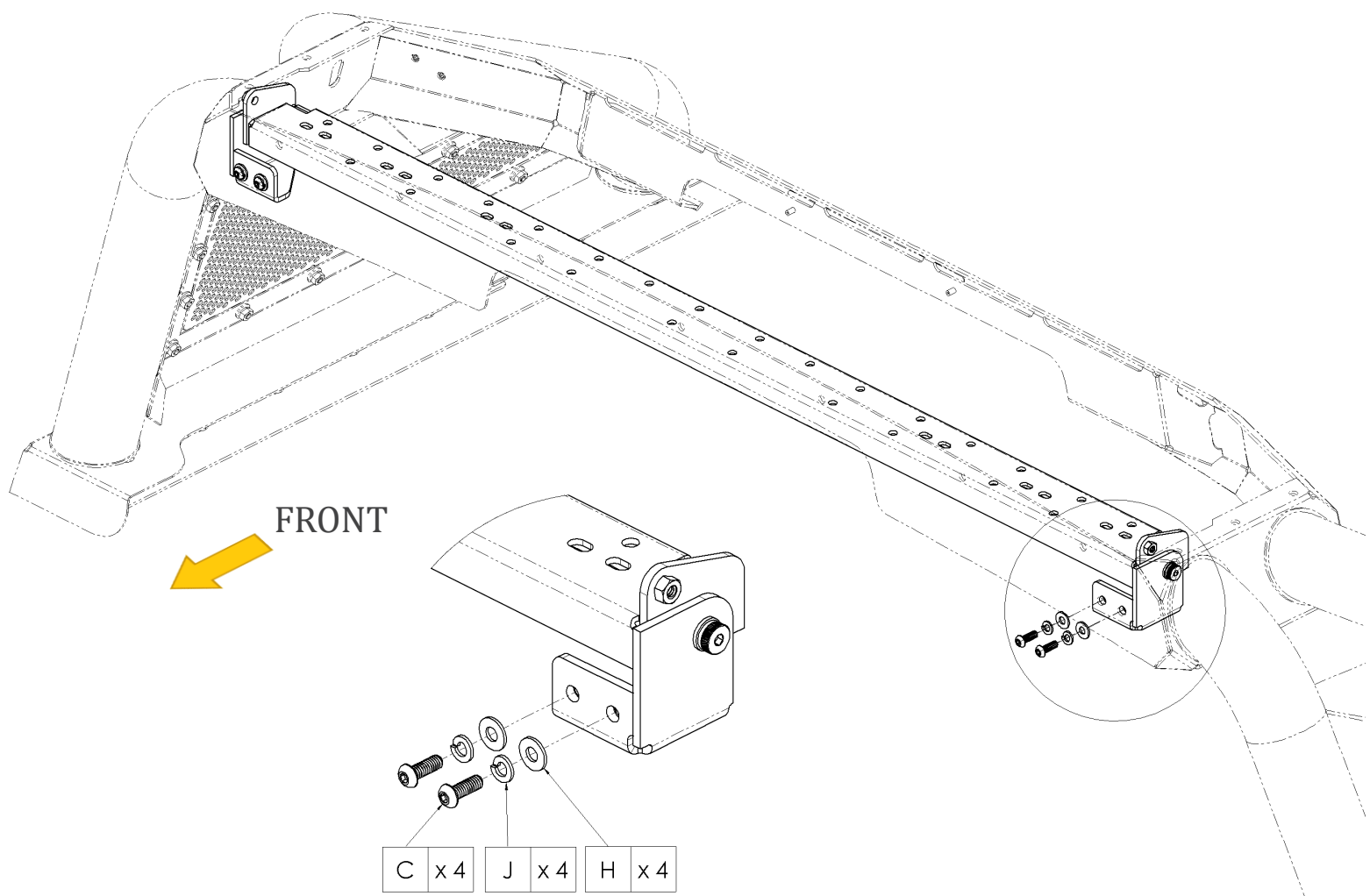

- Assemble light bar mount to Sport bar using (4)  $\frac{1}{4}$ " button head screws, (4)  $\frac{1}{4}$ " lock washers and (4)  $\frac{1}{4}$ " flat washers.
- Tighten screws to 70 in/lbs Max. DO NOT OVERTIGHTEN SCREWS.

# GORRHINO<sup>®</sup>

## INSTALLATION INSTRUCTIONS

### STEP # 3

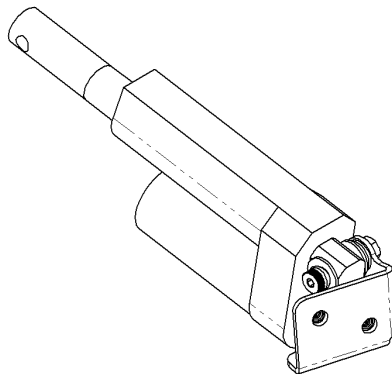
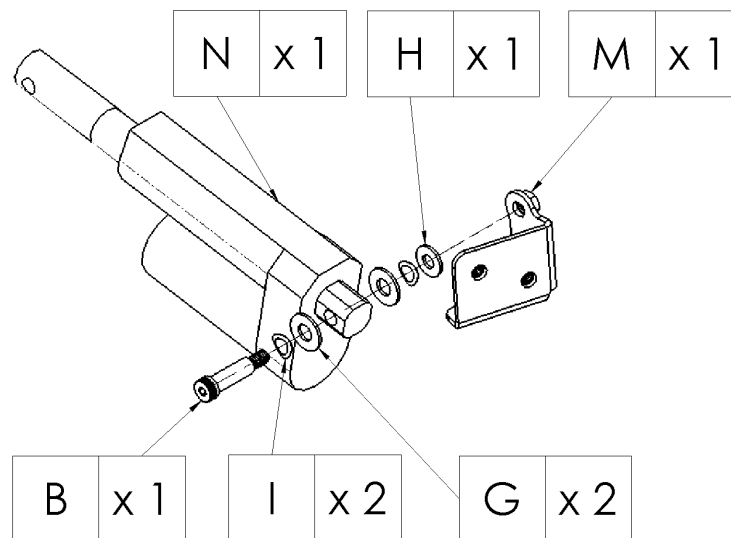

- Assemble actuator with rear bracket using (1)  $\frac{1}{4}$ " shoulder bolt, (2)  $\frac{5}{16}$ " disc spring, (2)  $\frac{5}{16}$ " flat washer and (1)  $\frac{1}{4}$ " flat washer.
- Tighten shoulder bolt to 50 in/lbs Max. DO NOT OVERTIGHTEN BOLT.

# GORRHINO®

## INSTALLATION INSTRUCTIONS

### STEP # 4

- Assemble actuator to light mount bar using (1)  $\frac{1}{4}$ " shoulder bolt, (2)  $\frac{5}{16}$ " disc spring, (2)  $\frac{5}{16}$ " flat washer and (1)  $\frac{1}{4}$ " flat washer.
- Tighten shoulder bolt to 50 in/lbs Max. DO NOT OVERTIGHTEN BOLT.

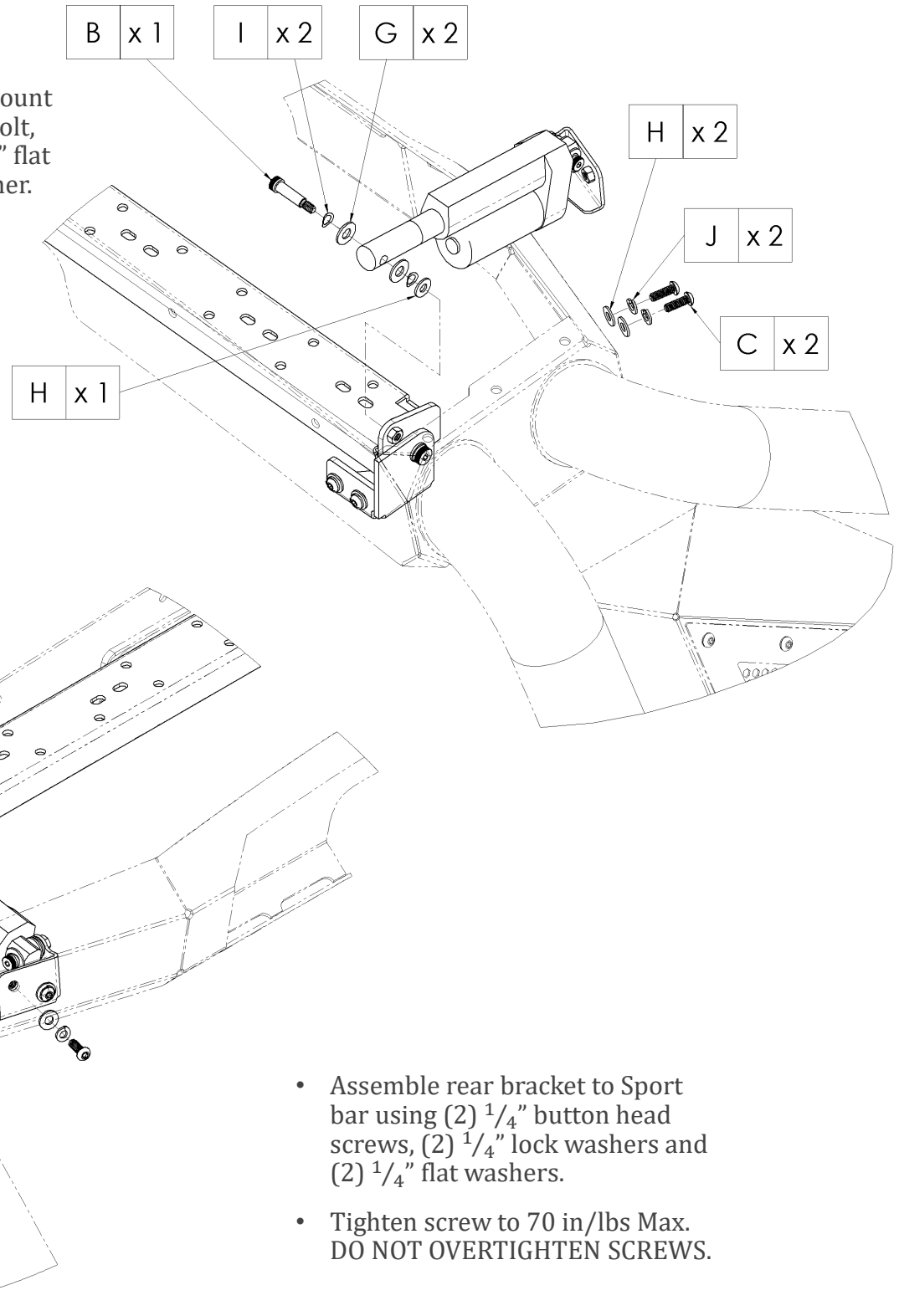

- Assemble rear bracket to Sport bar using (2)  $\frac{1}{4}$ " button head screws, (2)  $\frac{1}{4}$ " lock washers and (2)  $\frac{1}{4}$ " flat washers.
- Tighten screw to 70 in/lbs Max. DO NOT OVERTIGHTEN SCREWS.



# GORRHINO<sup>®</sup>

## INSTALLATION INSTRUCTIONS

### STEP # 5

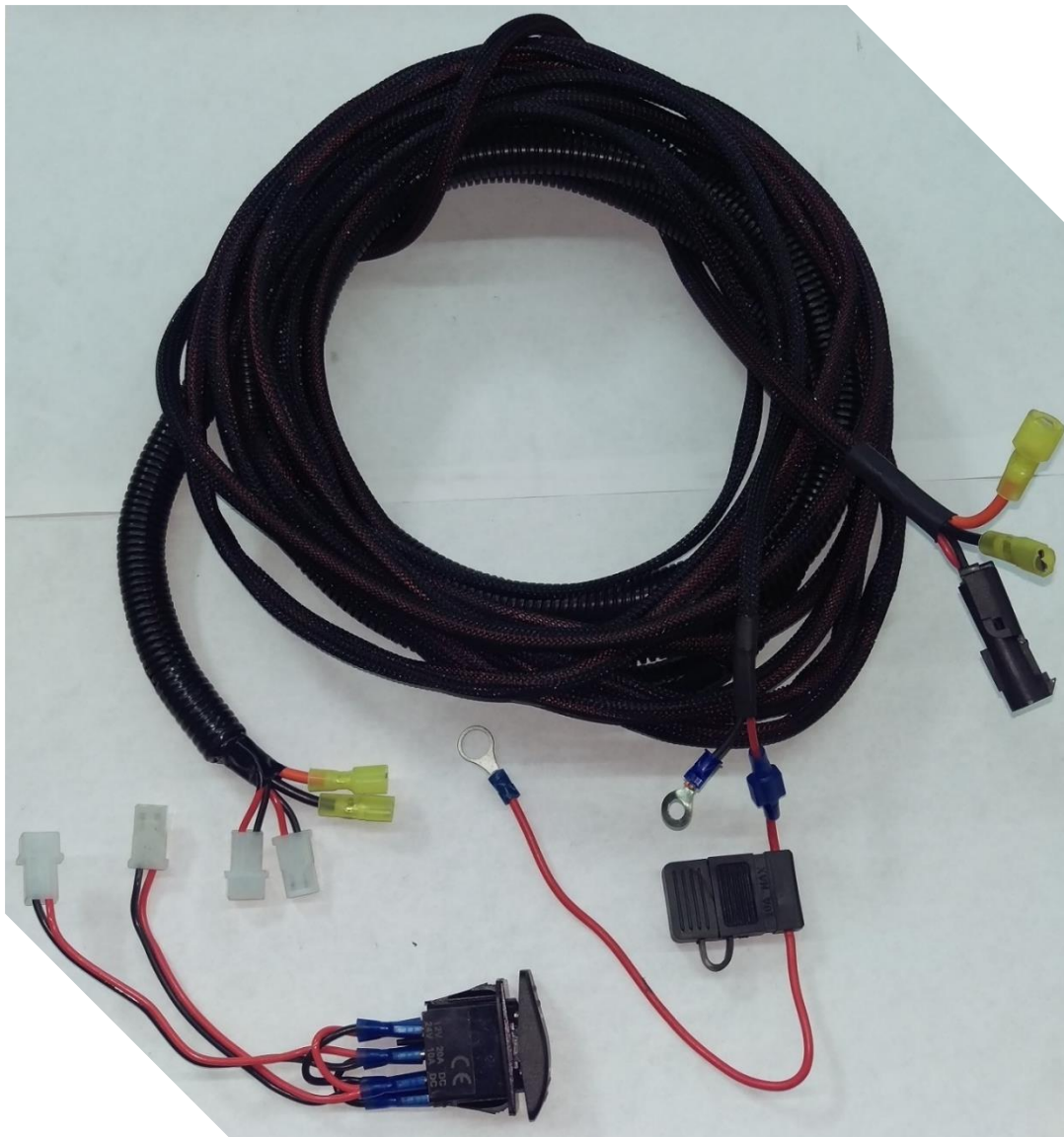

- Optional wiring for accessory lights.
- Be sure to use an adequate relay that corresponds to your system if required. When installing multiple lights, fusing should be adjusted to match.
- To actuator

# GO RHINO®

## INSTALLATION INSTRUCTIONS

### STEP # 6

- Run wire harness through tube.

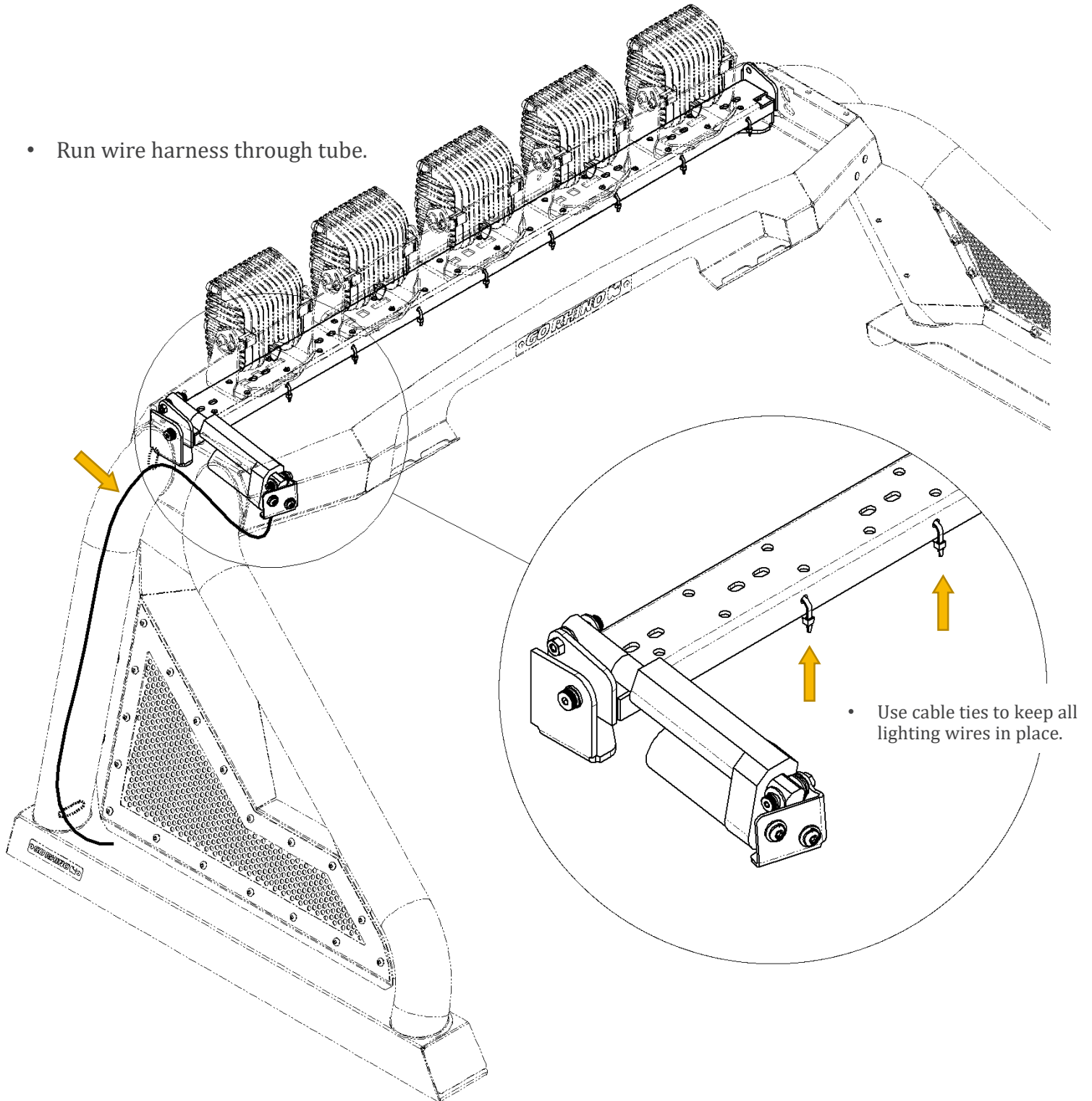

# GORRHINO®

## INSTALLATION INSTRUCTIONS

### STEP # 7

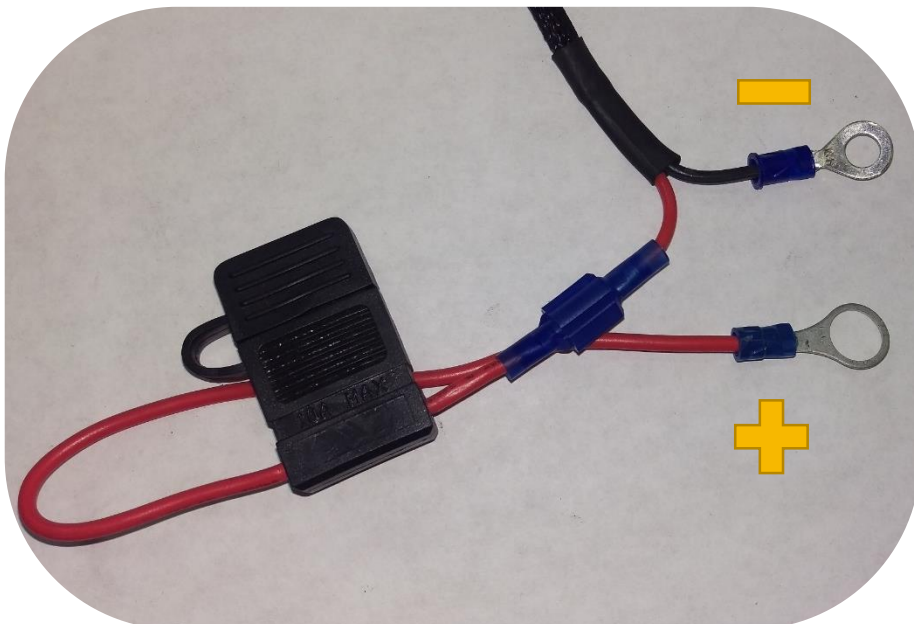

- Attach red terminal eyelet to battery positive. Secure black terminal eyelet to a suitable ground or battery negative.
- Beware of sharp edges, abrasive surfaces and heat sources when routing wires.

# GO RHINO®

## INSTALLATION INSTRUCTIONS

### STEP # 8

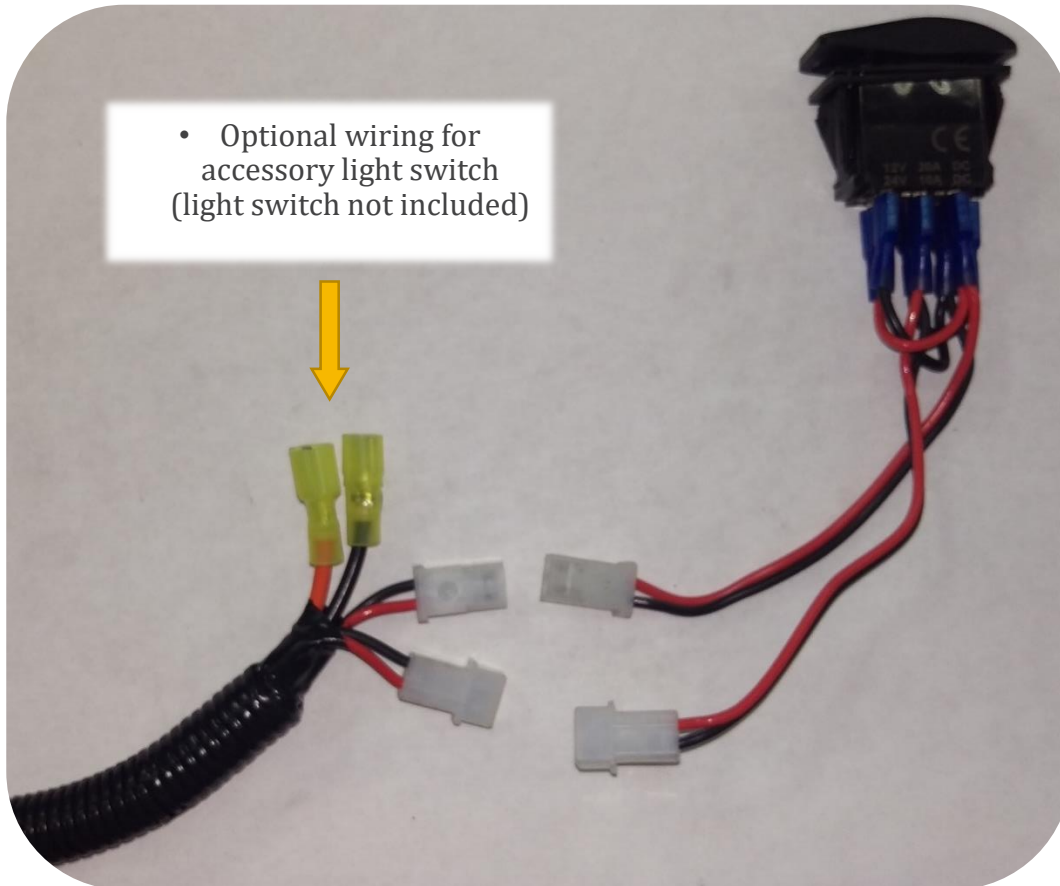

- 3 position switch  
0-Neutral  
I-Bar up  
II-Bar down

- Switch may be left in position I or II, which will keep indicator LED on.
- In order to turn off indicator LED, move switch to neutral position.

