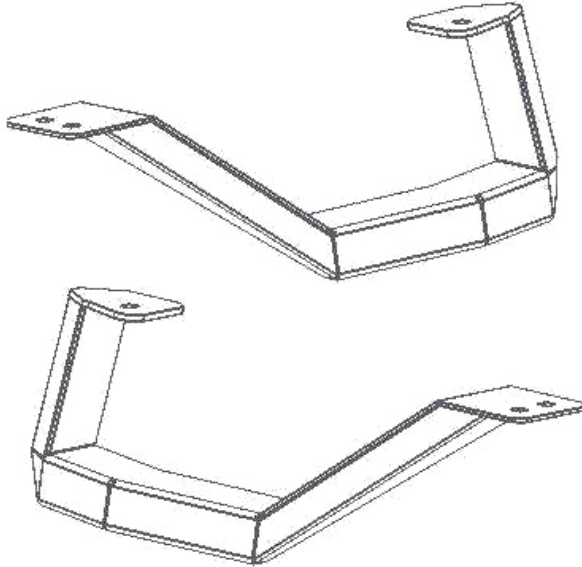


# GO RHINO®

## INSTALLATION INSTRUCTIONS



### PART NO.

- 69420000T
- 69420000PC

### PRODUCT DESCRIPTION:

- Straight RB Drop Steps

### PRODUCT SAFETY & LEGAL DISCLAIMER

- **IMPORTANT READ ALL INSTRUCTIONS CAREFULLY BEFORE INSTALLING, FAILURE TO DO SO MAY CAUSE PERSONAL INJURY OR DAMAGE TO PRODUCT AND/OR PROPERTY.**
- **Review the product package and contents prior to beginning the installation.** Take care when opening the packaging and removing items. If a return is needed you will want to return the product in its original packaging if possible.
- This instruction guide is provided as a GENERAL installation guide, some vehicles vary dimensionally and may require additional steps.
- Test fit the product on the vehicle prior to any third party modifications and or finishing. The manufacturer and/or distributors do not accept responsibility for third party charges, labor and or third part replacement modifications. Some modifications may void the factory warranty.
- Exercise due-diligence when installing this product. The manufacturer and distributors of this product do not accept any responsibility for vehicle damage or personal injury resulting from the installation of this product. Careless installation and operation can result in serious injury or equipment damage.
- This product is for general off-road use. All liability for installation and use rests with the owner/operator.
- **INSTALLER:** Once installation is complete, please return this guide along with other documentation included in this product back to the consumer for future reference. The manufacturer/distributors of this product do not guarantee this particular version will be available at a later date.



## INSTALLATION INSTRUCTIONS

### INJURY HAZARD

Please complete a shop and tool inspection prior to beginning the installation.

- Always make sure you have a clean, dry and well lit work area.
- Always remove jewelry, loose fitting clothing and wear protective gloves and eye protection.
- Always use extreme caution when jacking or raising a vehicle for work. Set the emergency brake and use tire/wheel blocks and jack stands. Refer to the vehicle manufacturer hand book. Utilize the vehicle manufacturers designated lifting points.
- Always use appropriate and adequate care in lifting parts during disassembly and installation. Seek help in lifting heavy or large items into place. Utilize jacks and or lifting devices when available.
- Always insure products are secure during disassembly and installation.
- Always wear eye protection and take steps to protect any exposed skin during the installations. Drilling, cutting and grinding plastic and metal may create flying particles that can cause injury.
- Always use extreme caution when drilling, cutting and or grinding on a vehicle. Thoroughly inspect the area to be drilled, on both sides of material, prior to modification and relocate any objects that may become damaged.
- Always assemble and tighten all fasteners per the installation instructions.
- Always route electrical cables carefully. Avoid moving parts, parts that may become hot and rough or sharp edges.
- Always insulate and protect all exposed wiring and electrical connections.

### MAINTENANCE AND CARE

- Always perform regular inspections and maintenance on mounts and related fasteners.
- Periodically check and tighten all fasteners.
- Stripped, fractured, or bent fasteners must be replaced.
- After washing the vehicle make sure to fully dry all surfaces.
- In areas with cold temperatures make sure to wash the product often to remove harmful materials used on road ways.
- Never use abrasive cleaners or polish compounds. Clean with a gentle soap and water. If you use wax use a non-abrasive automotive wax such as pure carnauba wax.

### WARNING

Some products have been designed to work together with factory rear sensor systems, factory forward facing sensor systems and factory air bags.

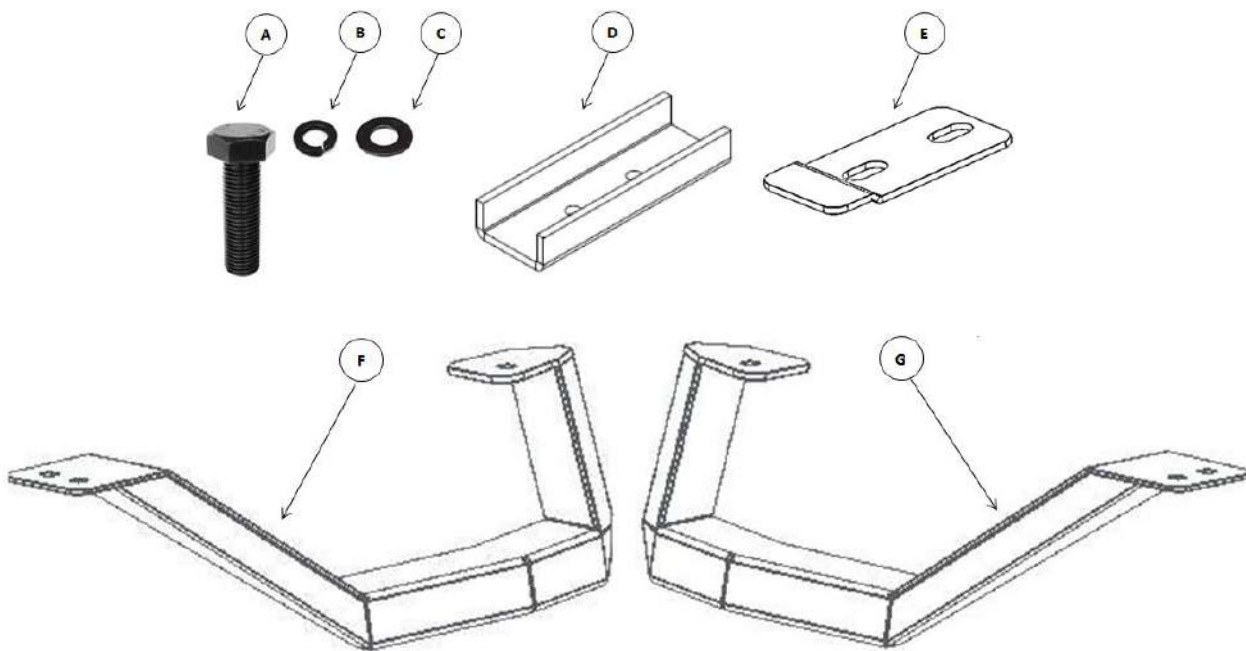
- Installation of some of these products may alter the factory sensor system performance.
- Factory sensors may read shackles or hooks protruding from the fairlead and or tow hooks.
- All sensor testing is completed by Go Rhino Products and or third party testing labs on modified vehicles.
- Sensor sensitivity, factory sensor housing, orientation, and operating conditions are all variables that will influence functionality of the sensors.
- Installation of some product may effect the factory air bag systems.
- Some products allow the use of third party products such as winches, shackles, hooks, etc. Follow the respective manufacturers operating instructions for use with our products.
- Make sure to fully understand the product, it's intended use and operation prior to use.
- Above all... be safe!

# GO RHINO®

## INSTALLATION INSTRUCTIONS

PARTS INCLUDED IN THIS LIST:

ITEM	QTY.	DESCRIPTION	ITEM	QTY.	DESCRIPTION
A	8	5/16" X 1" Hex Head Screw	E	2	Auxiliary Bracket
B	8	5/16" Lock washer	F	1	Driver Straight Drop Step
C	8	5/16" Flat Washer	G	1	Passenger Straight Drop Step
D	2	U-Bracket			



Go Rhino recommends you, the installer, read this installation instruction manual from front to back before installing the product.

### TOOLS NEEDED FOR INSTALLATION:

- 1/2" Wrench or Socket and Ratchet

ESTIMATED TIME FOR INSTALLATION:

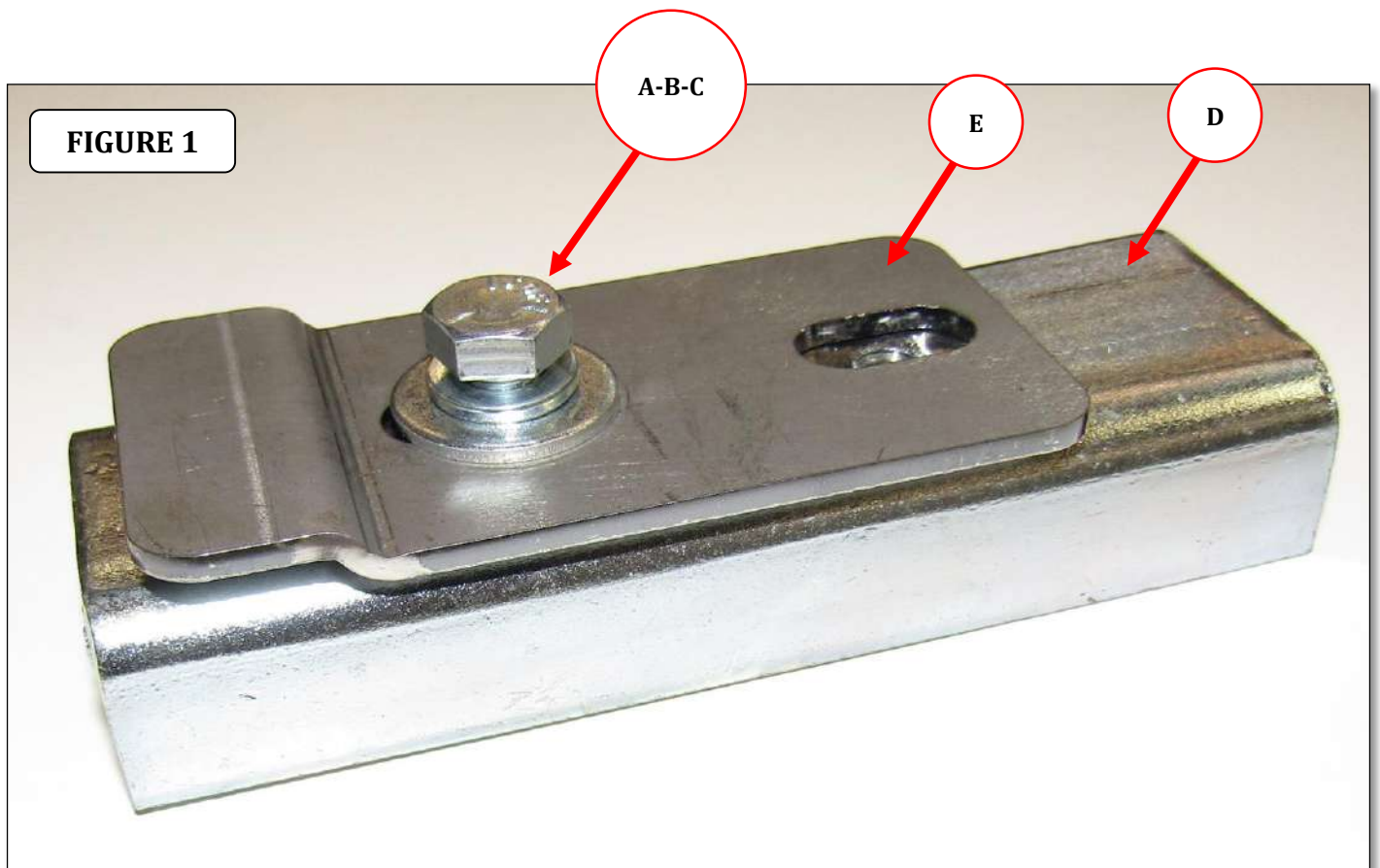
30 Min.

# GORRHINO®

## INSTALLATION INSTRUCTIONS

Typical RB Drop Step attachment to RB10 Running Board, driver side front or rear door position.

**Step-1** Attach the Auxiliary Bracket to the U-Bracket using (1) 5/16" x 1" hex head screw, (1) 5/16" lock washer and (1) 5/16" flat washer. Do not tighten the screw, (FIGURE 1).

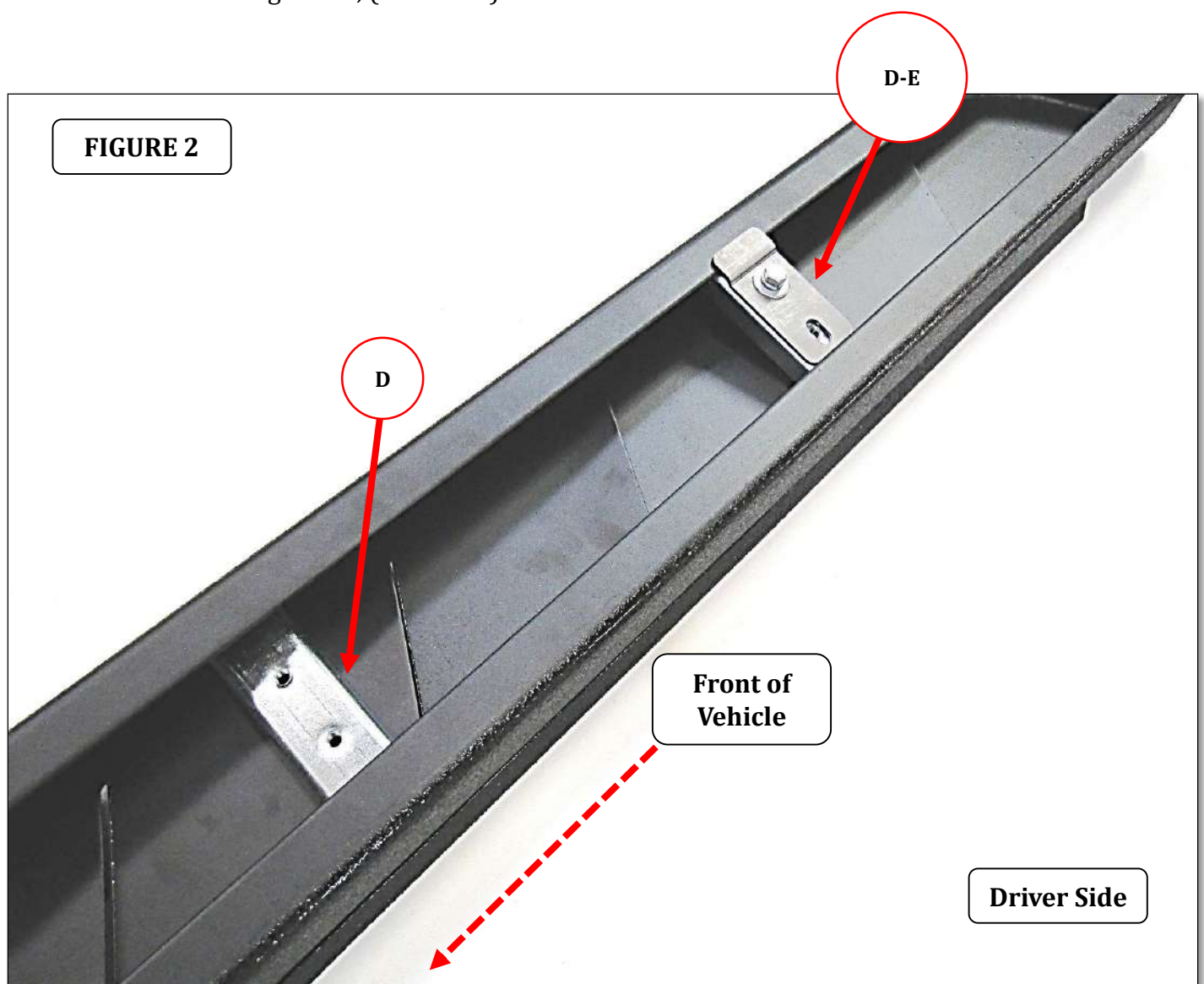


# GORRHINO<sup>®</sup>

## INSTALLATION INSTRUCTIONS

Typical RB Drop Step attachment to RB10 Running Board, driver side front or rear door position.

**Step-2** Determine the desired location of the driver side RB Drop Step on the RB10 Running Board, then position (1) U-Bracket toward the front of the vehicle and the Auxiliary Bracket and U-Bracket assembly toward the rear of the vehicle in the opening on the underside of the RB10 Running Board, (FIGURE 2).



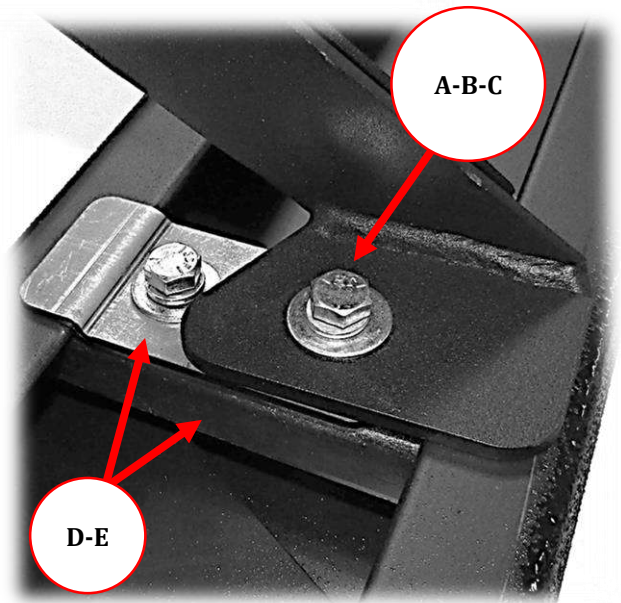
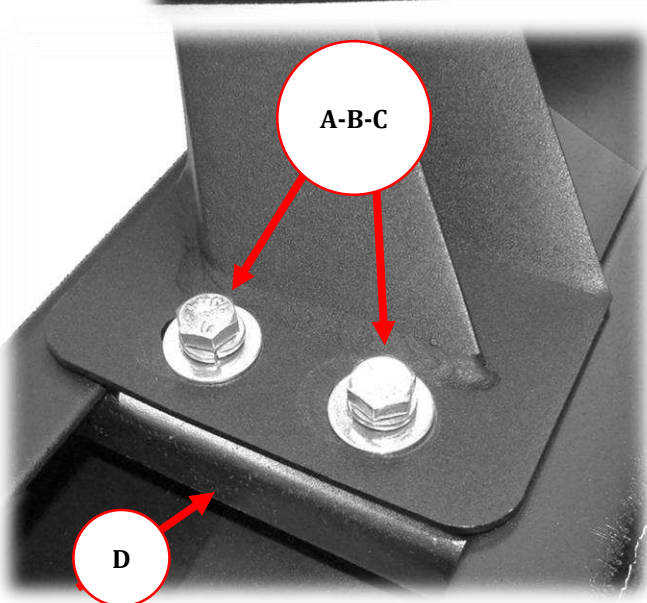
# GORRHINO<sup>®</sup>

## INSTALLATION INSTRUCTIONS

Typical RB Drop Step attachment to RB10 Running Board, driver side front or rear door position.

**Step-3a** Attach the driver side RB Drop Step to the RB10 Running Board using the U-Brackets (3) 5/16" flat washers, (3) 5/16" lock washers and (3) 5/16" x 1" hex head screws, (FIGURE 3). Tighten all screws securing the RB Drop Step, U-Brackets and Auxiliary bracket to the R10 Running Board. Repeat steps for the passenger side.

FIGURE 3



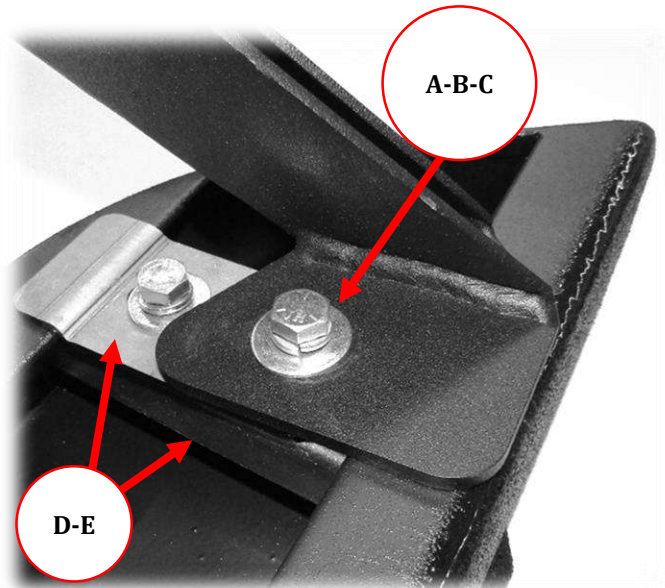
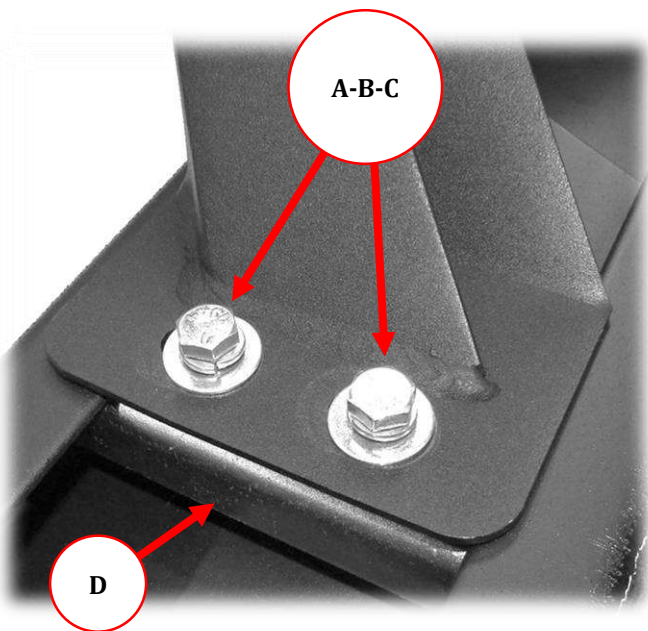
# GORRHINO®

## INSTALLATION INSTRUCTIONS

Typical RB Drop Step attachment to RB10 Running Board, Jeep Wrangler 4 door driver side rear door position.

**Step-3b** Attach the driver side RB Drop Step to the RB10 Running Board using the U-Brackets (3) 5/16" flat washers, (3) 5/16" lock washers and (3) 5/16" x 1" hex head screws, (FIGURE 4). Tighten all screws securing the RB Drop Step, U-Brackets and Auxiliary bracket to the R10 Running Board. Repeat steps for the passenger side.

FIGURE 4

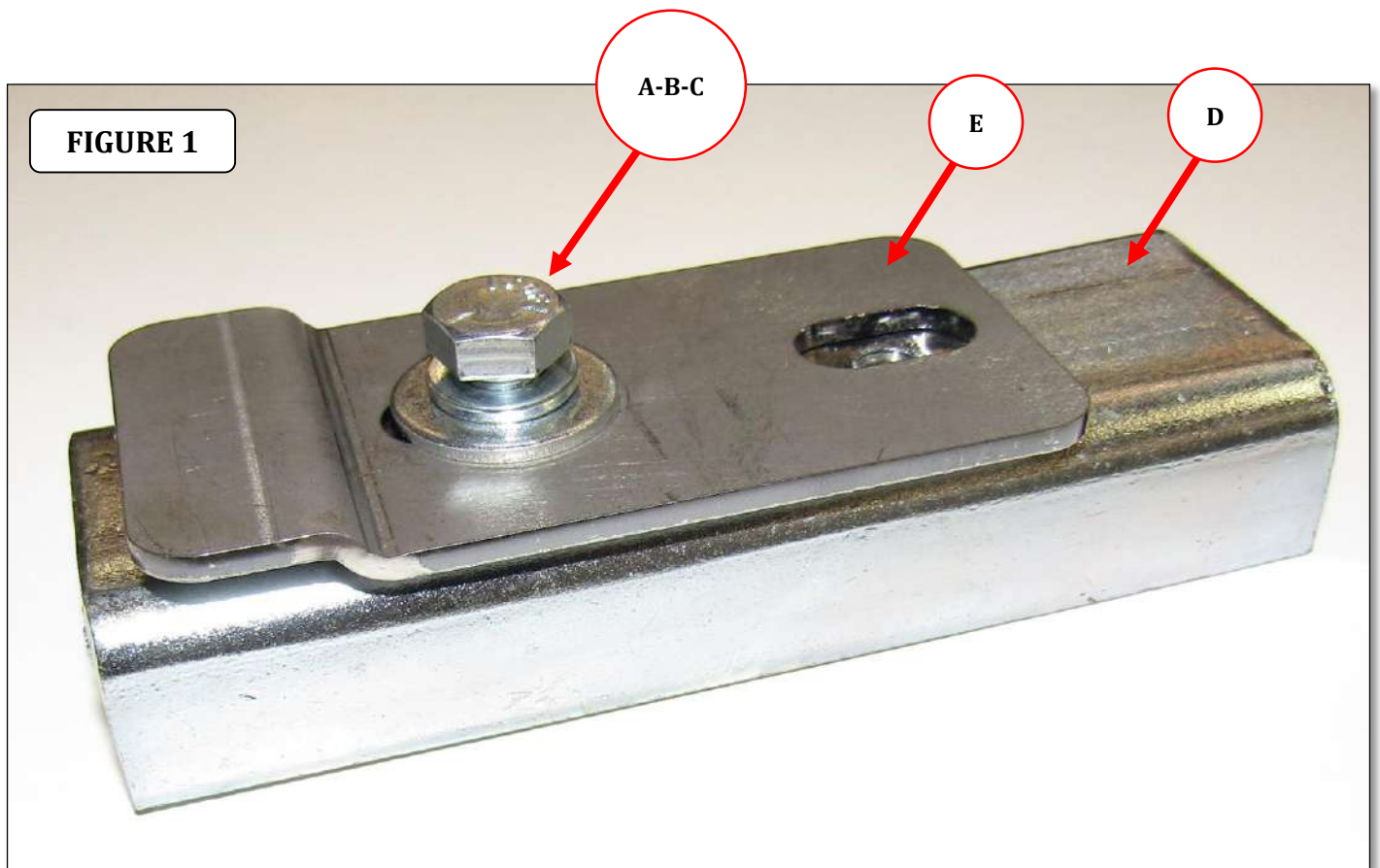


# GORRHINO®

## INSTALLATION INSTRUCTIONS

Typical RB Drop Step attachment to RB20 Running Board, driver side front or rear door position.

**Step-1** Attach the Auxiliary Bracket to the U-Bracket using (1) 5/16" x 1" hex head screw, (1) 5/16" lock washer and (1) 5/16" flat washer. Do not tighten the screw, (FIGURE 1).



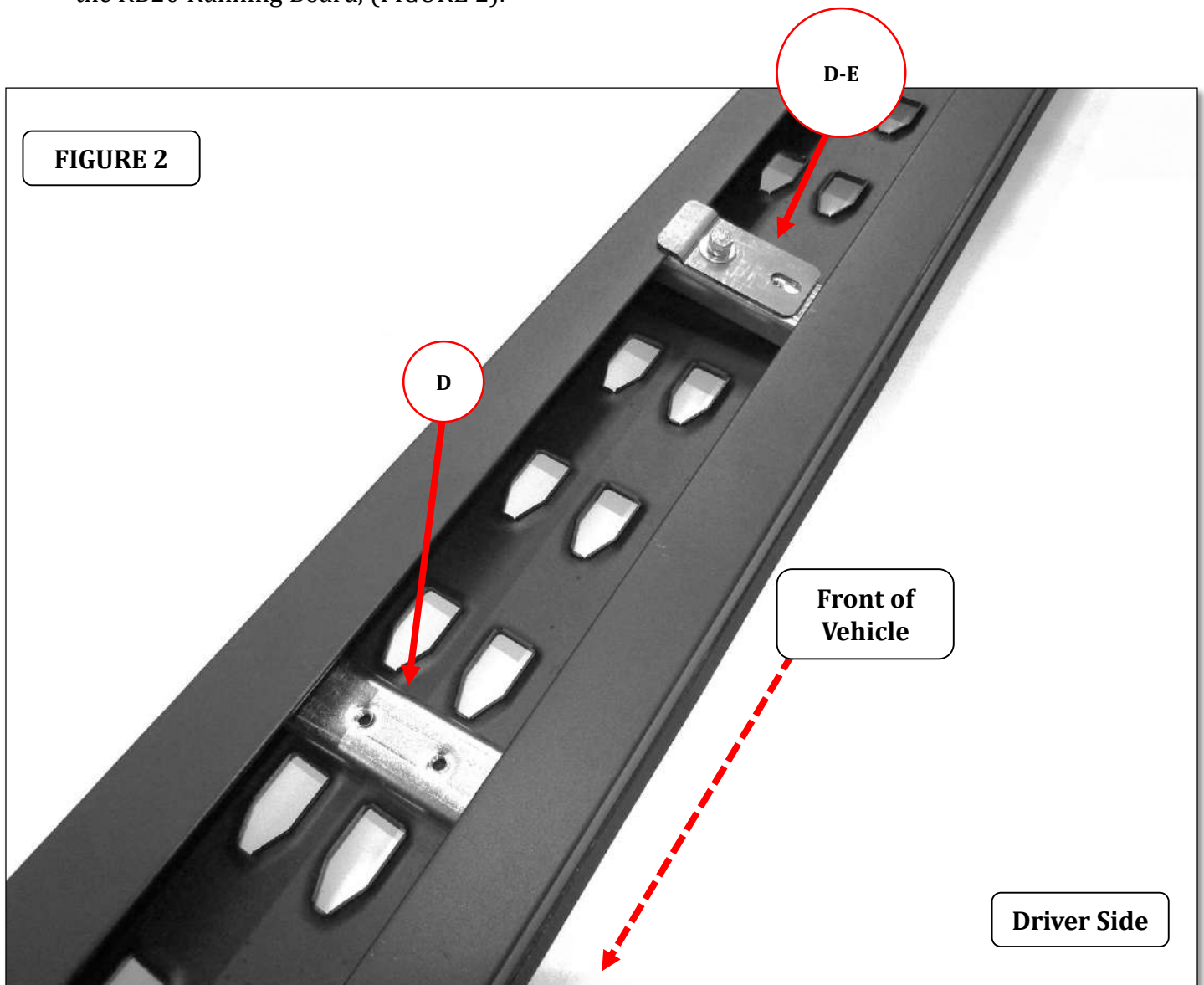


# GORRHINO®

## INSTALLATION INSTRUCTIONS

Typical RB Drop Step attachment to RB20 Running Board, driver side front or rear door position.

**Step-2** Determine the desired location of the driver side RB Drop Step on the RB20 Running Board, then position (1) U-Bracket toward the front of the vehicle and the Auxiliary Bracket and U-Bracket assembly toward the rear of the vehicle in the opening on the underside of the RB20 Running Board, (FIGURE 2).



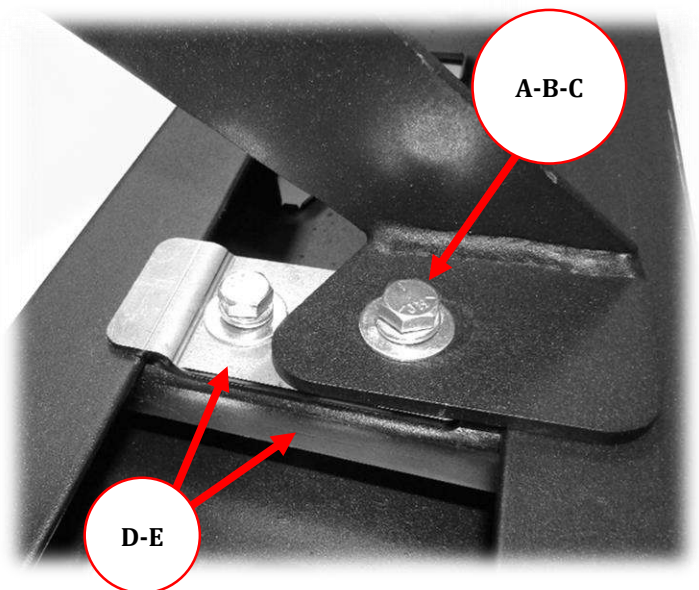
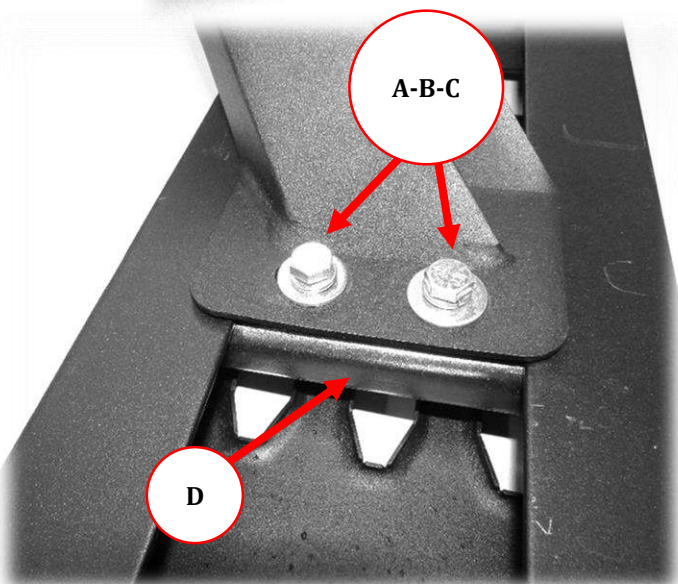
# GORRHINO<sup>®</sup>

## INSTALLATION INSTRUCTIONS

Typical RB Drop Step attachment to RB20 Running Board, driver side front or rear door position.

**Step-3a** Attach the driver side RB Drop Step to the RB20 Running Board using the U-Brackets (3) 5/16" flat washers, (3) 5/16" lock washers and (3) 5/16" x 1" hex head screws, (FIGURE 3). Tighten all screws securing the RB Drop Step, U-Brackets and Auxiliary bracket to the R20 Running Board. Repeat steps for the passenger side.

FIGURE 3



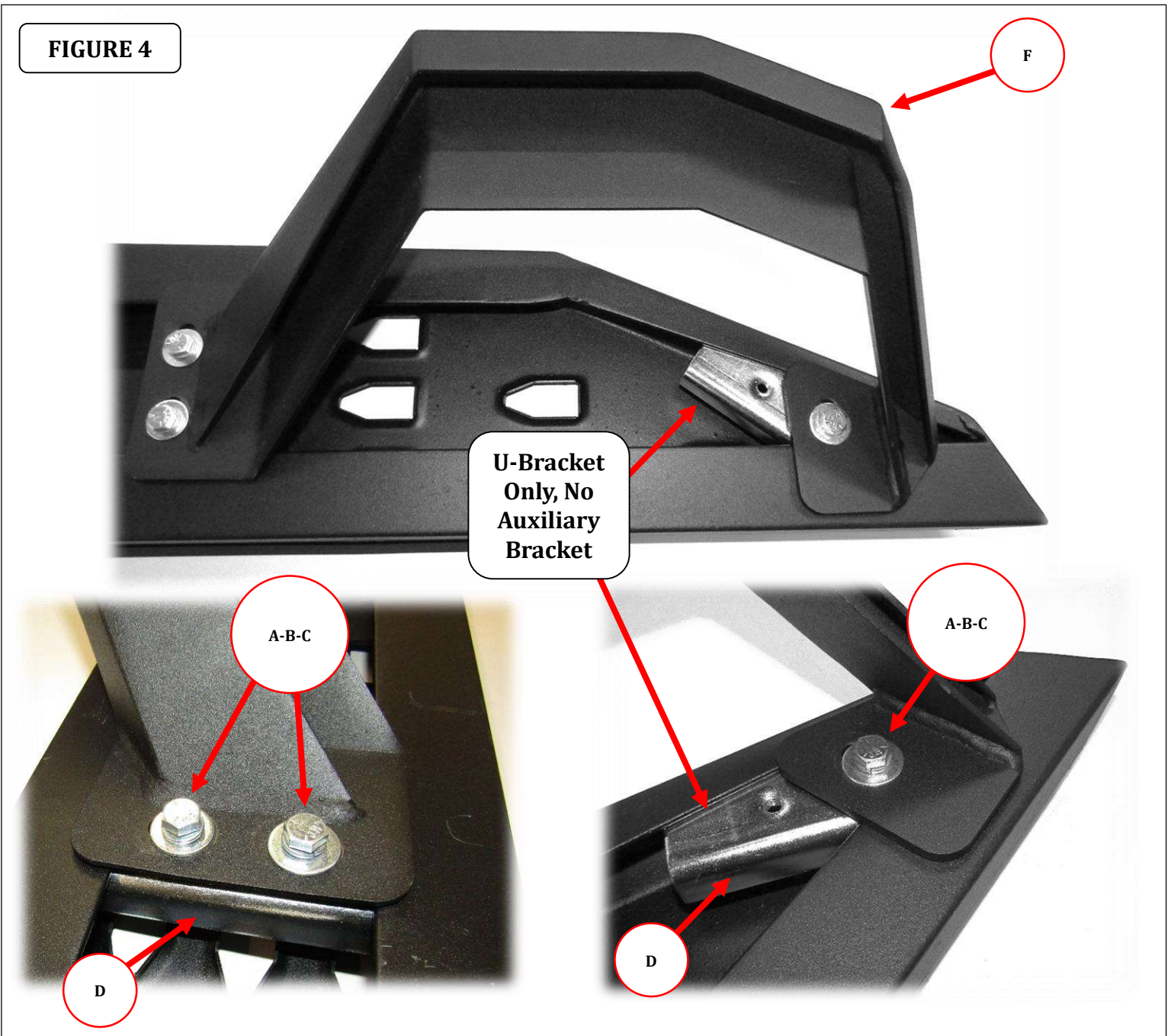
# GORRHINO<sup>®</sup>

## INSTALLATION INSTRUCTIONS

Typical RB Drop Step attachment to RB20 Running Board, Jeep Wrangler 4 door driver side rear door position.

**Step-3b** Attach the driver side RB Drop Step to the RB20 Running Board using the U-Brackets (3) 5/16" flat washers, (3) 5/16" lock washers and (3) 5/16" x 1" hex head screws, (FIGURE 4). Tighten all screws securing the RB Drop Step and U-Brackets to the R20 Running Board. Repeat steps for the passenger side.

FIGURE 4



# INSTALLATION INSTRUCTIONS

**RB10 SIDE STEPS PART # 63405880**

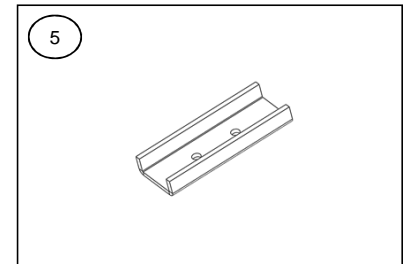
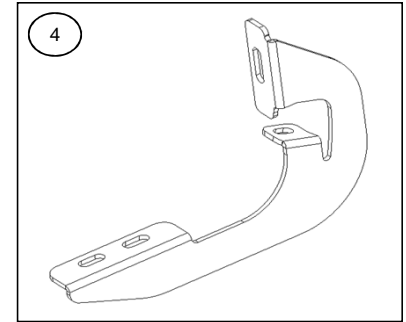
**RB20 SIDE STEPS PART # 69405880**

## CHEVROLET SILVERADO & GMC SIERRA DOUBLE CAB

**Do not attempt to install this product on any vehicle other than the one listed above!**

### PARTS LIST

ITEM	QTY.	PART #	DESCRIPTION	TORQUE
1	1	630080	RB10 Side Steps driver & passenger	-
1	1	6900080	RB20 Side Steps driver & passenger	-
2	1	BRK-6340475	Hardware brackets kit	-
3	8	6340474AA	Bracket	-
4	8	6300874AA/4BA	U bracket	-
5	1	KTE-634047B	Hardware kit	-
6	16	-	5/16 x 1" Hex head bolt black plated	11 Lb.ft
7	16	-	5/16" Flat washer black plated	-
8	16	-	5/16" Lock washer black plated	-
9	8	-	M8 Hex nut zinc plated	20 Lb.ft
10	16	-	M8 x 25mm Hex head bolt zinc plated	20 Lb.ft
11	8	-	M8 Clip nut zinc plated	20 Lb.ft
12	24	-	5/16" Flat washer zinc plated	-
13	16	-	5/16" Lock washer zinc plated	-



### ASSEMBLY & INSTALLATION TOOLS REQUIRED:

1/2" Socket & 1/2" Wrench  
 13mm Socket & 13mm Wrench  
 Ratchet  
 Extension.

**Approximate installation time: 40 min.**

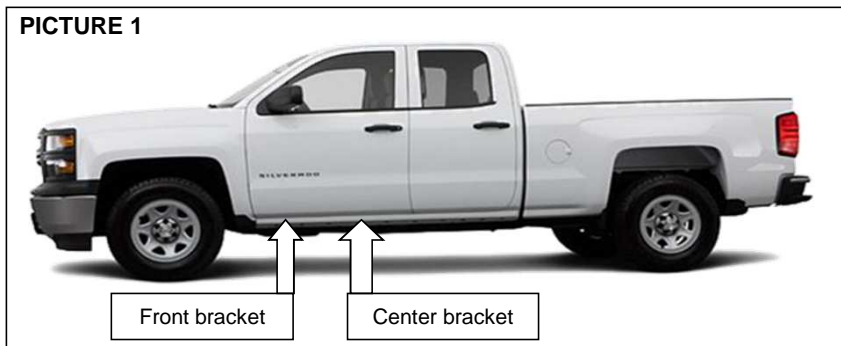
Read the assembly and installation instructions completely and verify that all of the parts listed are accounted for.

It is the customer's responsibility to protect the finish with a regular application of a nonabrasive polish compatible with the products finish. **NOTE: LOOK THE POSITION BEFORE INSTALLING THE BRACKETS.**

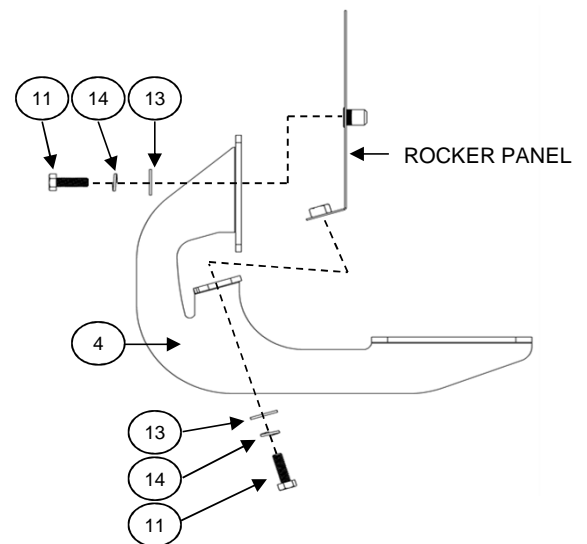
### INSTALLATION

**Step-1** Locate in the front and center in rocker panel of the vehicle the existing nut threaded hole. **SEE PICTURE 1 & 2.** Place the bracket and attach with: M8 hex head bolt, M8 flat and lock washers (zinc plated), according to the **ILLUSTRATION 1.** Leave loose. Repeat for the opposite side.

**PICTURE 1**

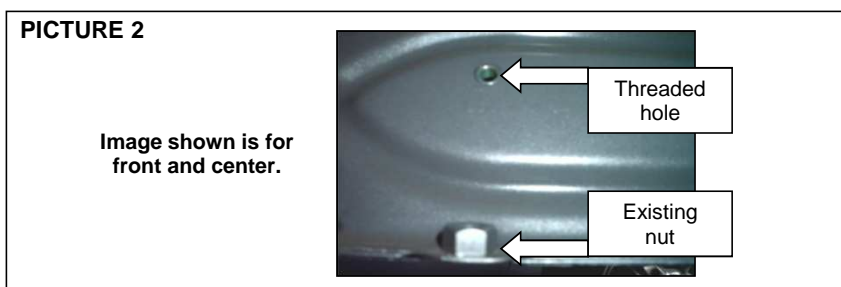


**ILLUSTRATION 1**

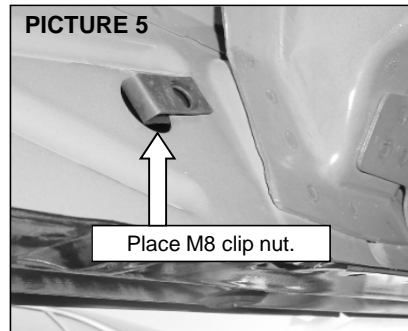
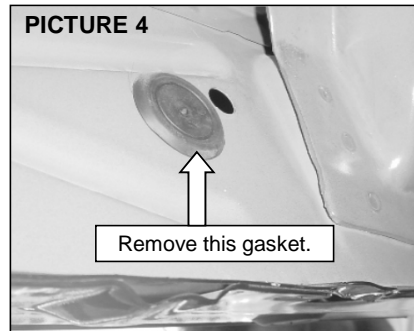
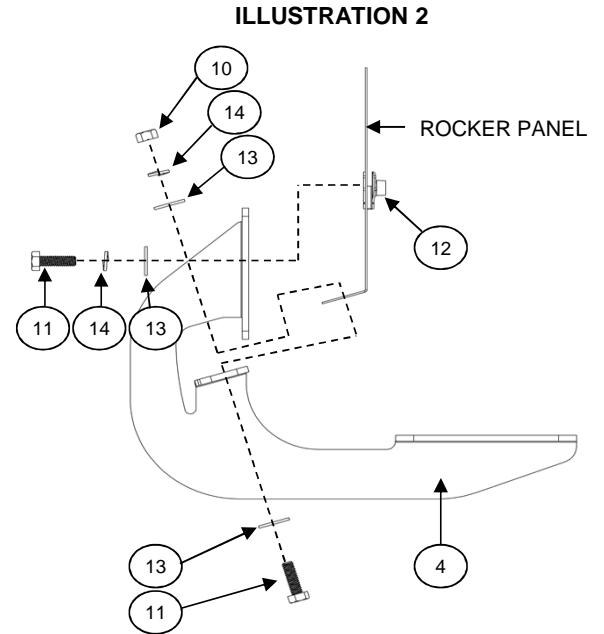
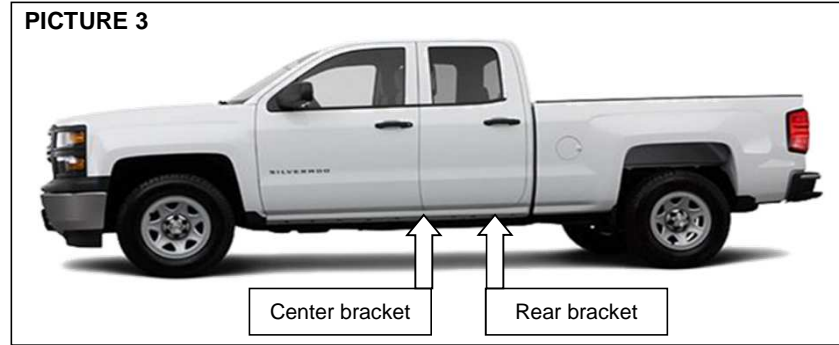


Use wrench, ratchet, hex socket 13mm.

**PICTURE 2**

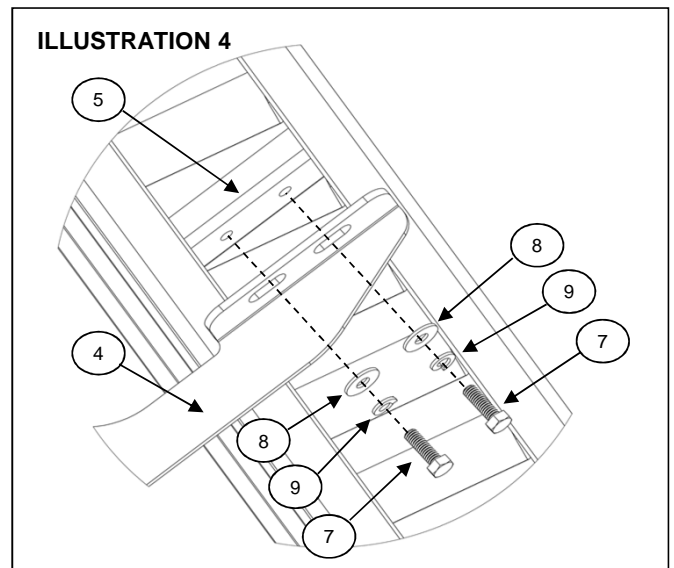
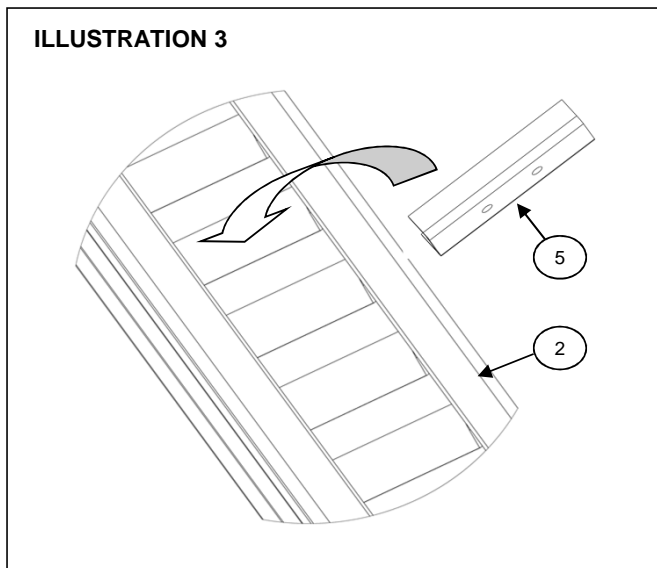


**Step-2** Locate in the center and rear in the rocker panel of the vehicle the hole and insert a M8 clip nut. **SEE PICTURE 3 & 4 & 5.** Place the bracket and attach with: M8 hex head bolt, M8 flat and lock washers, M8 hex nut (zinc plated), according to the **ILLUSTRATION 2.** Leave loose. Repeat for the opposite side.



Use wrench, ratchet, hex socket 13mm.

**Step-3** Place the U bracket and attach with: 5/16" hex head bolt, 5/16" Flat and lock washer (black plated), by each bracket. **SEE ILLUSTRATION 3 & 4.** Repeat for the opposite side. Leave loose.



Use ratchet & 1/2" hex socket.

**Step-4** Align the side bar and then tighten all bolts.

**Step-5** Periodically check your product because it may need a re-tighten of bolts.

**Step-6** Fill the warranty card and place it inside your vehicle's glove box.