

# GO RHINO®

## INSTALLATION INSTRUCTIONS

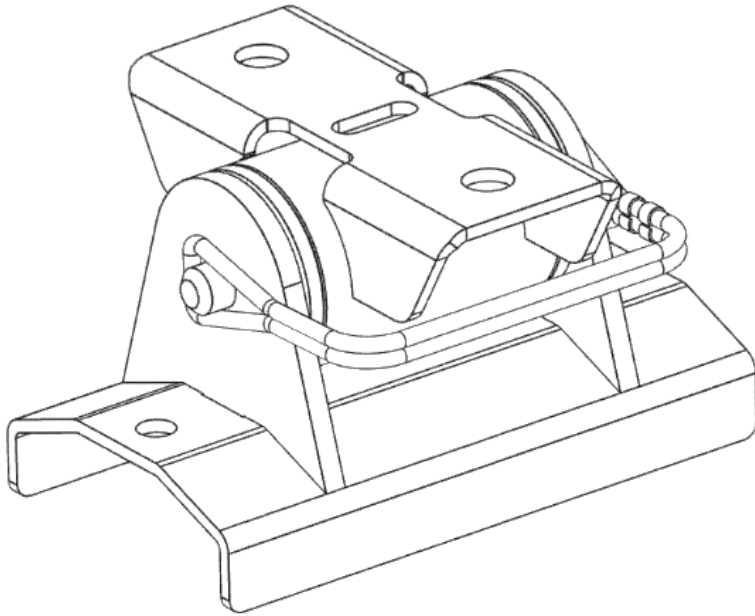

### PART NO.

- 5950030T

### PRODUCT DESCRIPTION:

- Quick Release Tent Bracket Kit

### APPLICATION:

- SRM400 Racks, SRM500 Racks & Overland Racks

## PRODUCT SAFETY & LEGAL DISCLAIMER

- **IMPORTANT READ ALL INSTRUCTIONS CAREFULLY BEFORE INSTALLING, FAILURE TO DO SO MAY CAUSE PERSONAL INJURY OR DAMAGE TO PRODUCT AND/OR PROPERTY.**
- **Review the product package and contents prior to beginning the installation.** Take care when opening the packaging and removing items. If a return is needed you will want to return the product in its original packaging if possible.
- This instruction guide is provided as a GENERAL installation guide, some vehicles vary dimensionally and may require additional steps.
- Test fit the product on the vehicle prior to any third party modifications and or finishing. The manufacturer and/or distributors do not accept responsibility for third party charges, labor and or third part replacement modifications. Some modifications may void the factory warranty.
- Exercise due-diligence when installing this product. The manufacturer and distributors of this product do not accept any responsibility for vehicle damage or personal injury resulting from the installation of this product. Careless installation and operation can result in serious injury or equipment damage.
- This product is for general off-road use. All liability for installation and use rests with the owner/operator.
- **INSTALLER:** Once installation is complete, please return this guide along with other documentation included in this product back to the consumer for future reference. The manufacturer/distributors of this product do not guarantee this particular version will be available at a later date.



## INSTALLATION INSTRUCTIONS

### INJURY HAZARD

Please complete a shop and tool inspection prior to beginning the installation.

- Always make sure you have a clean, dry and well lit work area.
- Always remove jewelry, loose fitting clothing and wear protective gloves and eye protection.
- Always use extreme caution when jacking or raising a vehicle for work. Set the emergency brake and use tire/wheel blocks and jack stands. Refer to the vehicle manufacturer hand book. Utilize the vehicle manufacturers designated lifting points.
- Always use appropriate and adequate care in lifting parts during disassembly and installation. Seek help in lifting heavy or large items into place. Utilize jacks and or lifting devices when available.
- Always insure products are secure during disassembly and installation.
- Always wear eye protection and take steps to protect any exposed skin during the installations. Drilling, cutting and grinding plastic and metal may create flying particles that can cause injury.
- Always use extreme caution when drilling, cutting and or grinding on a vehicle. Thoroughly inspect the area to be drilled, on both sides of material, prior to modification and relocate any objects that may become damaged.
- Always assemble and tighten all fasteners per the installation instructions.
- Always route electrical cables carefully. Avoid moving parts, parts that may become hot and rough or sharp edges.
- Always insulate and protect all exposed wiring and electrical connections.

### MAINTENANCE AND CARE

- Always perform regular inspections and maintenance on mounts and related fasteners.
- Periodically check and tighten all fasteners.
- Stripped, fractured, or bent fasteners must be replaced.
- After washing the vehicle make sure to fully dry all surfaces.
- In areas with cold temperatures make sure to wash the product often to remove harmful materials used on road ways.
- Never use abrasive cleaners or polish compounds. Clean with a gentle soap and water. If you use wax use a non-abrasive automotive wax such as pure carnauba wax.

### WARNING

Some products have been designed to work together with factory rear sensor systems, factory forward facing sensor systems and factory air bags.

- Installation of some of these products may alter the factory sensor system performance.
- Factory sensors may read shackles or hooks protruding from the fairlead and or tow hooks.
- All sensor testing is completed by Go Rhino Products and or third party testing labs on modified vehicles.
- Sensor sensitivity, factory sensor housing, orientation, and operating conditions are all variables that will influence functionality of the sensors.
- Installation of some product may effect the factory air bag systems.
- Some products allow the use of third party products such as winches, shackles, hooks, etc. Follow the respective manufacturers operating instructions for use with our products.
- Make sure to fully understand the product, it's intended use and operation prior to use.
- Above all... be safe!

# GO RHINO®

## INSTALLATION INSTRUCTIONS

### PARTS INCLUDED IN THIS LIST:

ITEM	QTY.	PART NUMBER	DESCRIPTION	TORQUE	ITEM	QTY.	PART NUMBER	DESCRIPTION
A	8	AST-T870G4	1/4" x 3/4" Hex Bolt	8 ft-lbs	D	8	AST-TU119G4	1/4" Hex Nut
B	8	AST-RPR70G4	1/4" Lock Washer		E	4	5950030AA	Quick Release Tent Bracket Assembly
C	8	AST-RP21G4	1/4" Flat Washer					

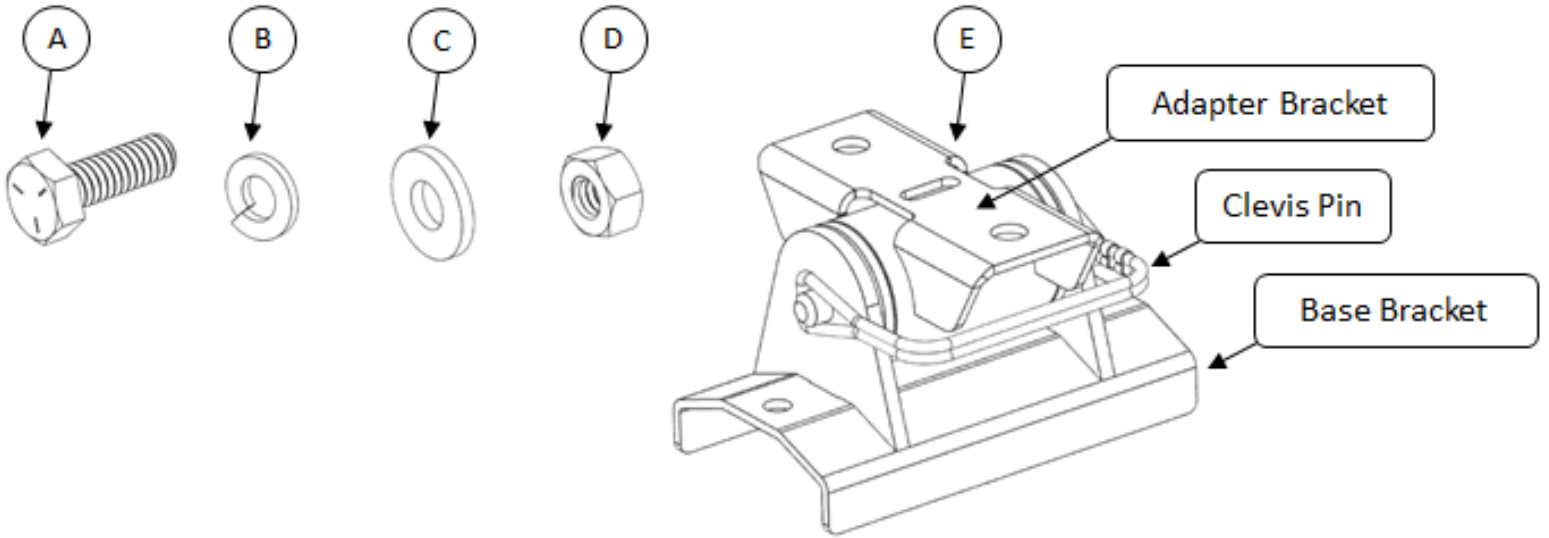

Go Rhino recommends you, the installer, read this installation instruction manual from front to back before installing the product.

### TOOLS NEEDED FOR INSTALLATION:

- 7/16" Wrench

ESTIMATED TIME FOR INSTALLATION:

1 Hour

# GORRHINO®

## INSTALLATION INSTRUCTIONS

**Step-1** Measure the length, and from center to center of aluminum track system rails on the underside of your tent, and note the measurements.

Fig 1

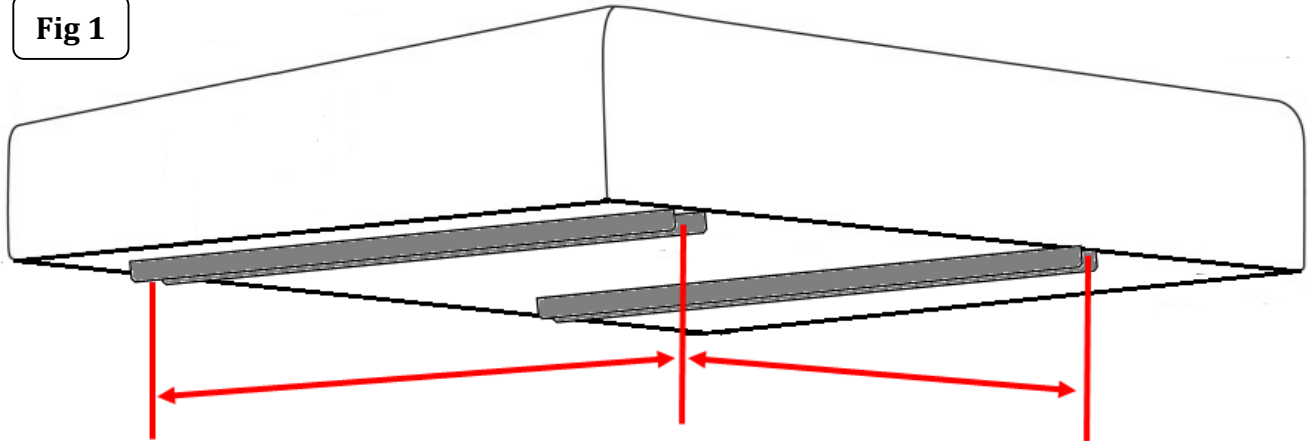

**Step-2** Using the noted measurements of the aluminum track system rails on the underside of your tent, determine the placement of the Quick Release Tent Bracket assembly on your SRM Rack crossbars or Overland Rack crossbars.

Fig 2

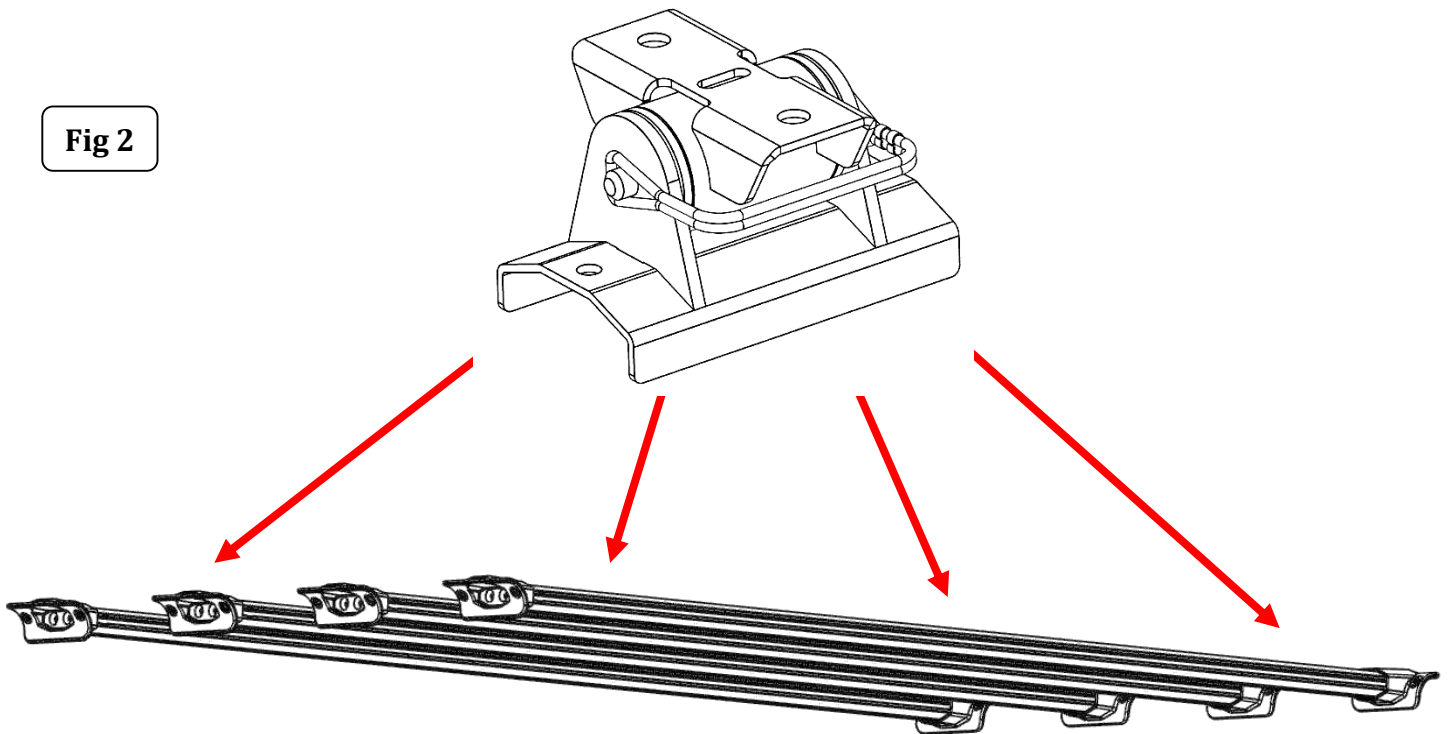

# GORRHINO®

## INSTALLATION INSTRUCTIONS

**Step-3** For each Quick Release Tent Bracket assembly, Install and position (2)  $\frac{1}{4}$ " x  $\frac{3}{4}$ " hex bolts in the center channel of the SRM Rack crossbar or Overland Rack crossbar, (Fig 3).

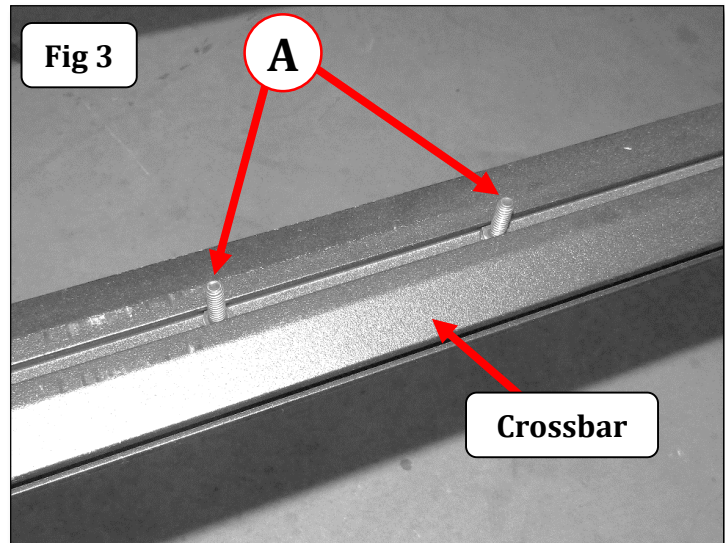

**Step-4** Align the (2)  $\frac{1}{4}$ " x  $\frac{3}{4}$ " hex bolts installed in the crossbar with the (2) holes in the base bracket of the Quick Release Tent Bracket assembly, and position the base bracket on the crossbar so the  $\frac{1}{4}$ " x  $\frac{3}{4}$ " hex bolts are protruding through the holes in the base bracket, (Fig 4).

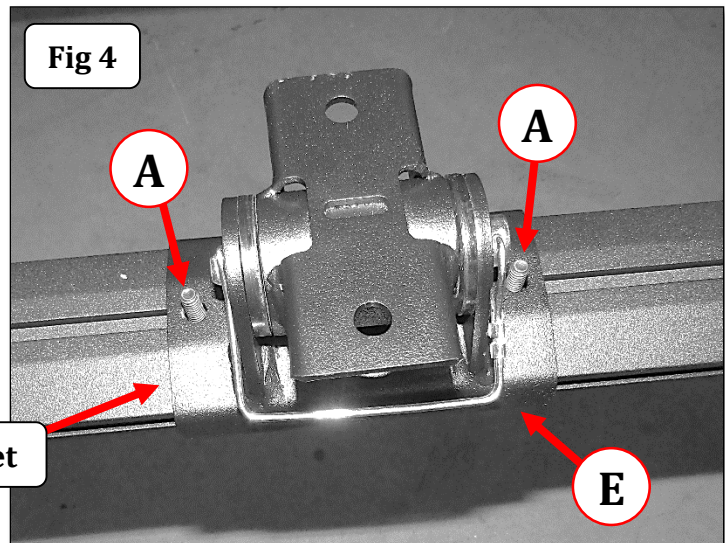

**Step-5** Secure the base bracket of the Quick Release Tent Bracket assembly to the crossbar using (2)  $\frac{1}{4}$ " flat washers, (2)  $\frac{1}{4}$ " lock washers and (2)  $\frac{1}{4}$ " hex nuts, (Fig 5). Sung but do not tighten the nuts and bolts. Repeat for the remaining Quick Release Tent Brackets assemblies.

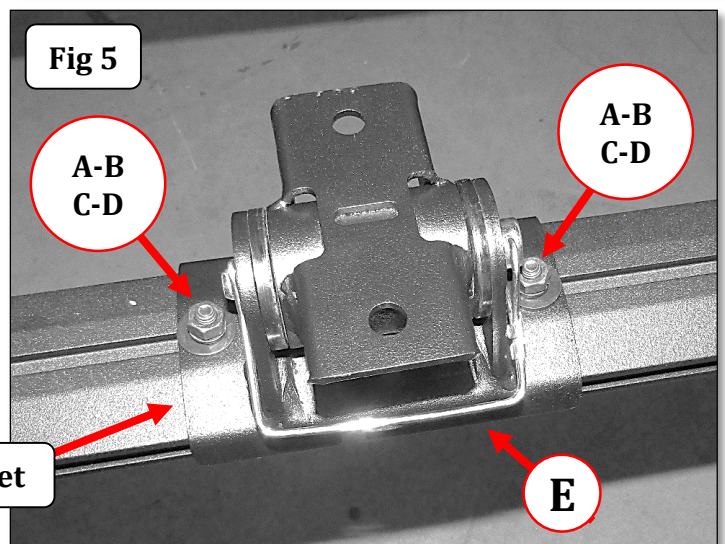

# GORRHINO®

## INSTALLATION INSTRUCTIONS

**Step-6** With assistance place the tent so the aluminum track system rails are resting on top of the adapter bracket of the Quick Release Tent Bracket assemblies, (Fig 6).

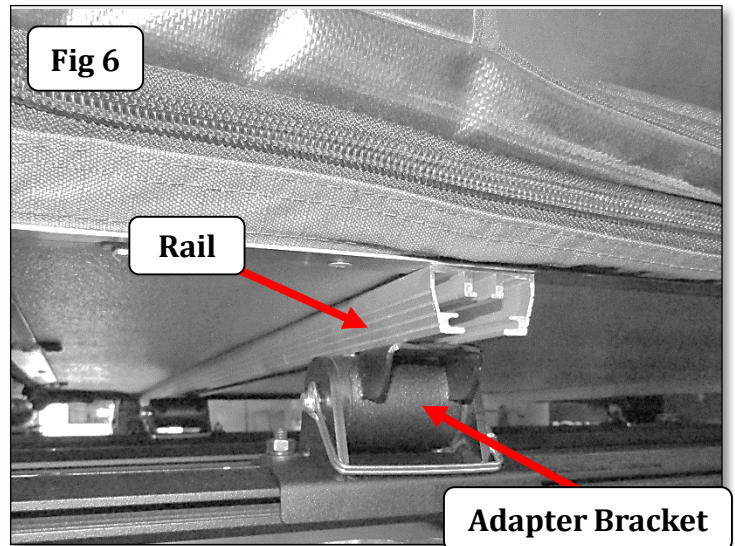

**Step-7** Lifting one corner of the tent at a time, attach the tent aluminum track system rails to the adapter bracket using the components and fasteners (bolts, washers and nuts) supplied with the tent, (Fig 7 & 8).

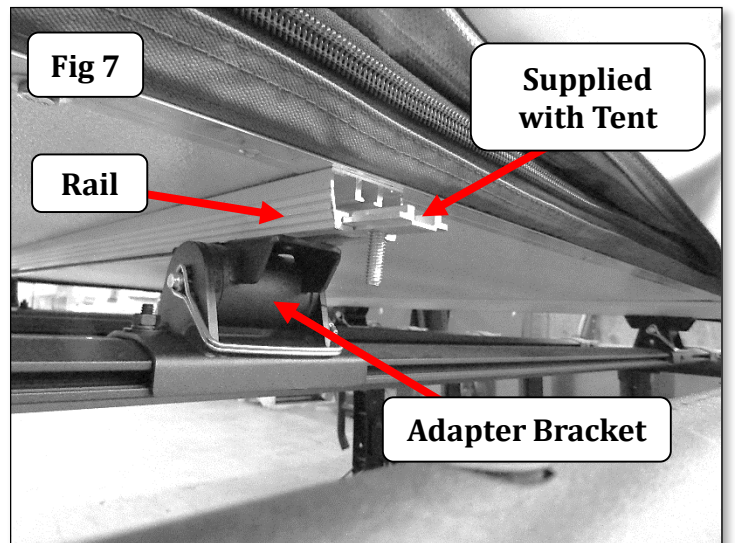

**Step-8** Align the tent and Quick Release Tent Bracket assemblies on the SRM Rack or Overland Rack. Tighten all nuts and bolts securing the track system rails to the adapter brackets then tighten the nuts and bolts securing the base brackets to SRM Rack crossbars or Overland Rack crossbars.

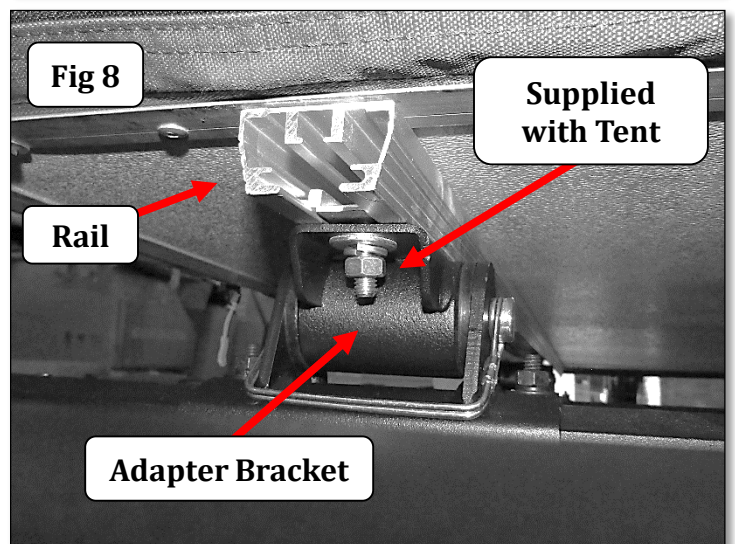

# GORRHINO<sup>®</sup>

## INSTALLATION INSTRUCTIONS

To remove the tent from the SRM Rack or Overland Rack, pull the wire loop away from the clevis pin. To remove the clevis pin, grasp the wire loop of the pin and pull it out of the base and adapter bracket it is inserted into. Resistance will be experienced due to the weight of the tent on the clevis pin and the Quick Release Tent Bracket assembly. Continue to pull the clevis pin until it is completely free from the base and adapter bracket. With assistance remove the tent from the SRM Rack or Overland Rack.

