

GO RHINO®

INSTALLATION INSTRUCTIONS

PART NO.

- 595000T

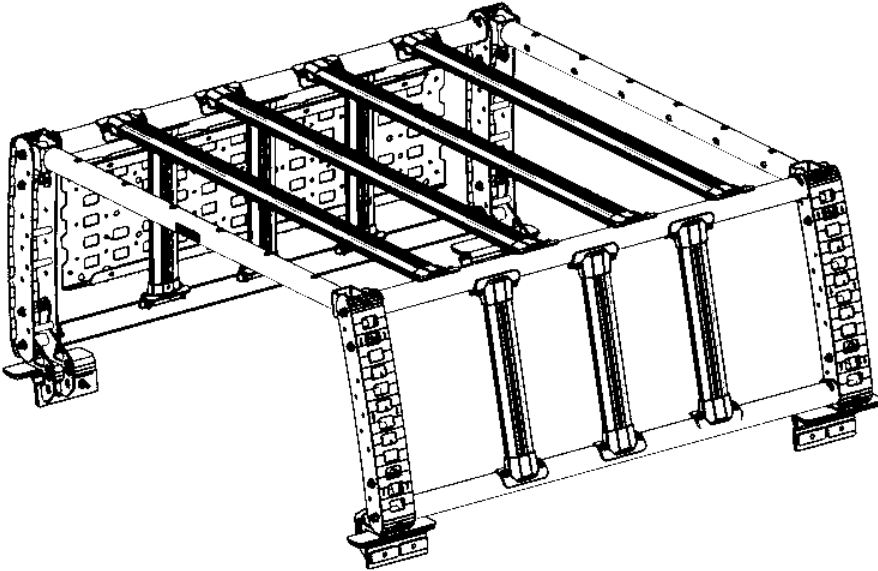

PRODUCT DESCRIPTION:

- Overland Truck Bed Rack

PRODUCT SAFETY & LEGAL DISCLAIMER

- **IMPORTANT READ ALL INSTRUCTIONS CAREFULLY BEFORE INSTALLING, FAILURE TO DO SO MAY CAUSE PERSONAL INJURY OR DAMAGE TO PRODUCT AND/OR PROPERTY.**
- **Review the product package and contents prior to beginning the installation.** Take care when opening the packaging and removing items. If a return is needed you will want to return the product in its original packaging if possible.
- This instruction guide is provided as a GENERAL installation guide, some vehicles vary dimensionally and may require additional steps.
- Test fit the product on the vehicle prior to any third party modifications and or finishing. The manufacturer and/or distributors do not accept responsibility for third party charges, labor and or third part replacement modifications. Some modifications may void the factory warranty.
- Exercise due-diligence when installing this product. The manufacturer and distributors of this product do not accept any responsibility for vehicle damage or personal injury resulting from the installation of this product. Careless installation and operation can result in serious injury or equipment damage.
- This product is for general off-road use. All liability for installation and use rests with the owner/operator.
- **INSTALLER:** Once installation is complete, please return this guide along with other documentation included in this product back to the consumer for future reference. The manufacturer/distributors of this product do not guarantee this particular version will be available at a later date.



INSTALLATION INSTRUCTIONS

INJURY HAZARD

Please complete a shop and tool inspection prior to beginning the installation.

- Always make sure you have a clean, dry and well lit work area.
- Always remove jewelry, loose fitting clothing and wear protective gloves and eye protection.
- Always use extreme caution when jacking or raising a vehicle for work. Set the emergency brake and use tire/wheel blocks and jack stands. Refer to the vehicle manufacturer hand book. Utilize the vehicle manufacturers designated lifting points.
- Always use appropriate and adequate care in lifting parts during disassembly and installation. Seek help in lifting heavy or large items into place. Utilize jacks and or lifting devices when available.
- Always insure products are secure during disassembly and installation.
- Always wear eye protection and take steps to protect any exposed skin during the installations. Drilling, cutting and grinding plastic and metal may create flying particles that can cause injury.
- Always use extreme caution when drilling, cutting and or grinding on a vehicle. Thoroughly inspect the area to be drilled, on both sides of material, prior to modification and relocate any objects that may become damaged.
- Always assemble and tighten all fasteners per the installation instructions.
- Always route electrical cables carefully. Avoid moving parts, parts that may become hot and rough or sharp edges.
- Always insulate and protect all exposed wiring and electrical connections.

MAINTENANCE AND CARE

- Always perform regular inspections and maintenance on mounts and related fasteners.
- Periodically check and tighten all fasteners.
- Stripped, fractured, or bent fasteners must be replaced.
- After washing the vehicle make sure to fully dry all surfaces.
- In areas with cold temperatures make sure to wash the product often to remove harmful materials used on road ways.
- Never use abrasive cleaners or polish compounds. Clean with a gentle soap and water. If you use wax use a non-abrasive automotive wax such as pure carnauba wax.

WARNING

Some products have been designed to work together with factory rear sensor systems, factory forward facing sensor systems and factory air bags.

- Installation of some of these products may alter the factory sensor system performance.
- Factory sensors may read shackles or hooks protruding from the fairlead and or tow hooks.
- All sensor testing is completed by Go Rhino Products and or third party testing labs on modified vehicles.
- Sensor sensitivity, factory sensor housing, orientation, and operating conditions are all variables that will influence functionality of the sensors.
- Installation of some product may effect the factory air bag systems.
- Some products allow the use of third party products such as winches, shackles, hooks, etc. Follow the respective manufacturers operating instructions for use with our products.
- Make sure to fully understand the product, it's intended use and operation prior to use.
- Above all... be safe!

GO RHINO®

INSTALLATION INSTRUCTIONS

PARTS INCLUDED IN THIS LIST:

ITEM	QTY	DESCRIPTION
1	2	Upper Connecting Tubes (w/ logo)
2	2	Top Connecting Tubes (single weep hole)
3	2	Bottom Connecting Tubes (two weep holes)
4	4	Vertical Upright
5	6	Upper Multi-Core Cross bars (long)
6	8	Side Multi-Core Cross bars (short)
7	8	Threaded Anchor Plates
8	1	Molly Accessory Plate
9	2	Bed Rail Mount (Pair)
10	8	Bed Track Mounting Plates
11	4	Bed Rail Clamp
12	8	16 Gauge Spacer (1 ¼")
13	16	4 Gauge Spacer (1 ¼")

HARDWARE INCLUDED IN THIS LIST:

ITEM	QTY	DESCRIPTION
14	6	¼" x ¾" Hex Head Bolt
15	6	¼" Hex Nut
16	8	3/8" x 4" Hex Head Bolt
17	40	¼"x1" Button Head Bolt
18	8	¼" x3/4" Button Head Bolt
19	54	¼" Flat Washer
20	54	¼" Lock Washer
21	16	3/8" x1" Hex Head Bolt
22	16	3/8" Hex Nut
23	40	3/8" Flat Washer
24	24	3/8 Lock Washer
25	8	5/16"x 1 ½" Carriage Bolt
26	8	5/16" Flat Washer
27	8	5/16" Lock Washer
28	8	5/16 Nut
29	4	5MM Adhesive Foam Pad
30	16	2 ¼" Vinyl Washer
31	16	1 ½" Vinyl Washer

Go Rhino recommends you, the installer, read this installation instruction manual from front to back before installing the product.

TOOLS NEEDED FOR INSTALLATION:

- ½ Wrench or Sockets
- 9/16 Wrench or Sockets
- 4MM Allen Key

ESTIMATED TIME FOR INSTALLATION:

3-4 Hours

GORRHINO®

INSTALLATION INSTRUCTIONS

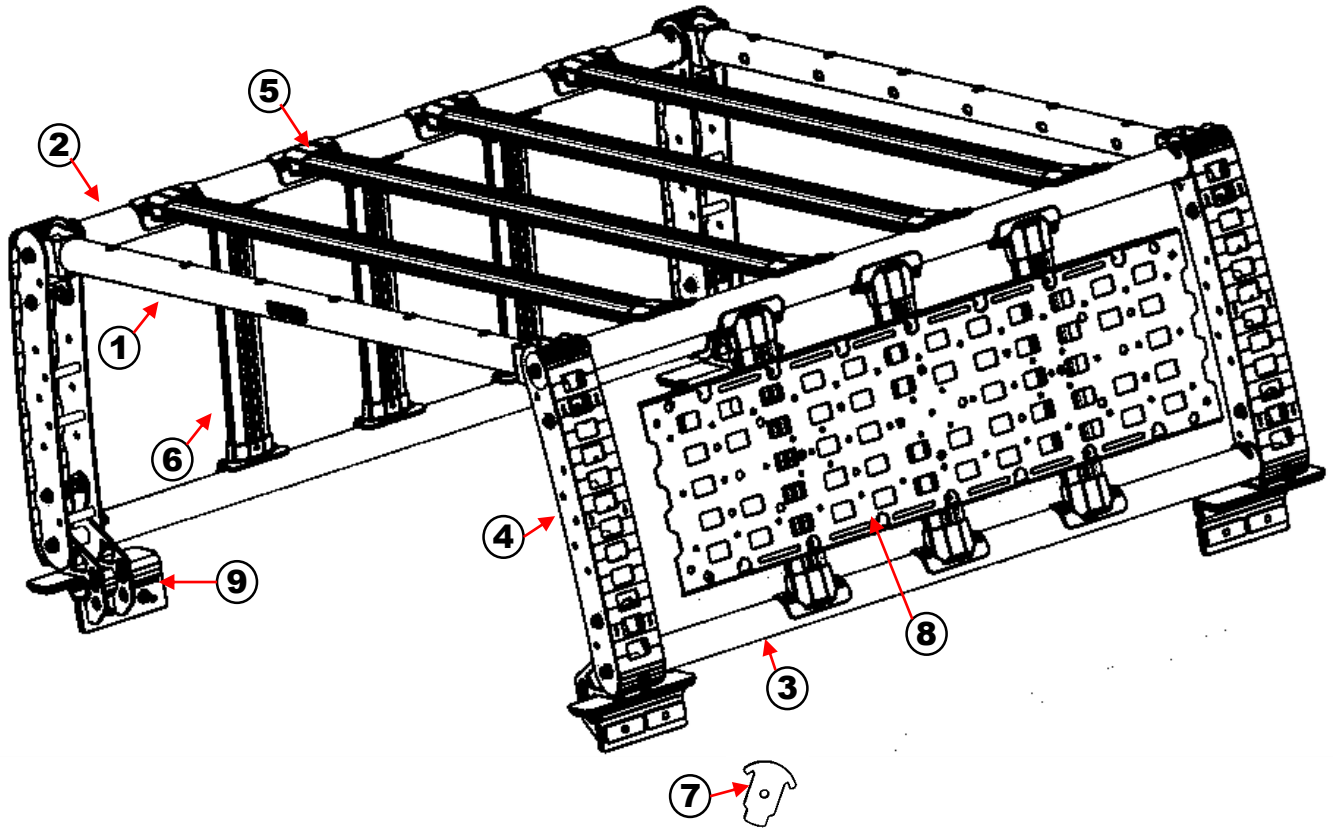

ITEM	QTY	DESCRIPTION
1	2	Upper Connecting Tubes (w/ logo)
2	2	Top Connecting Tubes (single weep hole)
3	2	Bottom Connecting Tubes (two weep holes)
4	4	Vertical Upright
5	4	Upper Multi-Core Cross bars (long)
6	6	Side Multi-Core Cross bars (short)
7	8	Threaded Anchor Plates
8	1	Molly Accessory Plate
9	2	Rack Mounting Feet (Pair)
10	4	Bed Track Mounting Plates
11	4	Bed Rail Clamp
12	8	16 Gauge Spacer (1 ¼")
13	16	4 Gauge Spacer (1 ¼")



INSTALLATION INSTRUCTIONS

Pre-assembly Tips

Layout the main components on a moving blanket or cardboard sheet. Doing so will help you identify all the parts and prevent any damage to the finish. To start the assembly, you're starting the top section of the rack in an upside down fashion. You'll be assembling one corner and repeat the steps 3 more times for each top corner. Parts and hardware needed for each upper corner are below.

Item	QTY	Description
1	1	Upper Connecting Tubes (w/ logo)
4	1	Vertical Upright
2	1	Upper Connecting Tube <small>**The top tubes can be identified by the single weep hole on the bottom**</small>
7	1	Threaded Anchor Plate
12	2	16 Gauge Round Spacer
13	1	14Gauge Round Spacer
16	1	3/8"x4" Hex Head bolt
21	2	3/8"x1" Hex Head bolt
22	2	3/8" Nut
23	3	3/8" Flat Washer
24	3	3/8" Lock Washer
31	2	1 1/2" Vinyl Washer
30	3	2 1/4 Vinyl Washer

GO RHINO®

INSTALLATION INSTRUCTIONS

Step 1

Connect vertical upright to logo plate, u-section of logo cross bar goes inside the upright. Install 3/8" x4" hex head bolt with 3/8" lock washer, 3/8" flat washer through upright. Before the bolt runs through, you will need to add 2 qty 2 1/4" Vinyl Washer in between (one per side) *****INSTALLATION TIP*** Use painters tape to hold the vinyl washer in place when assembling it.**

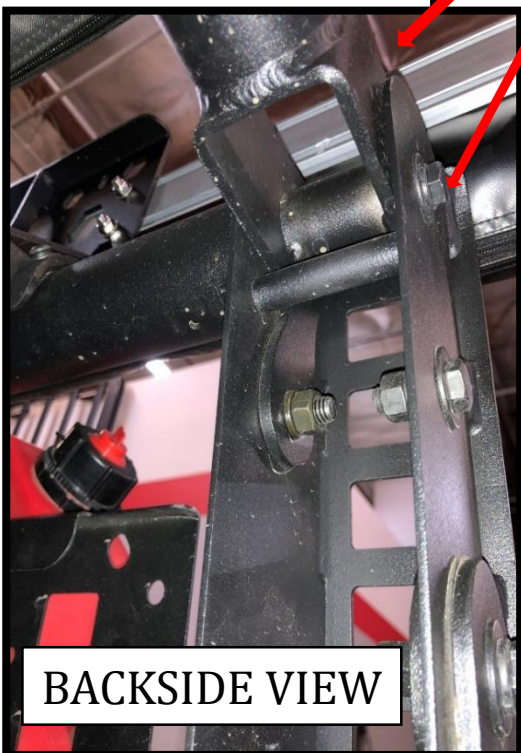
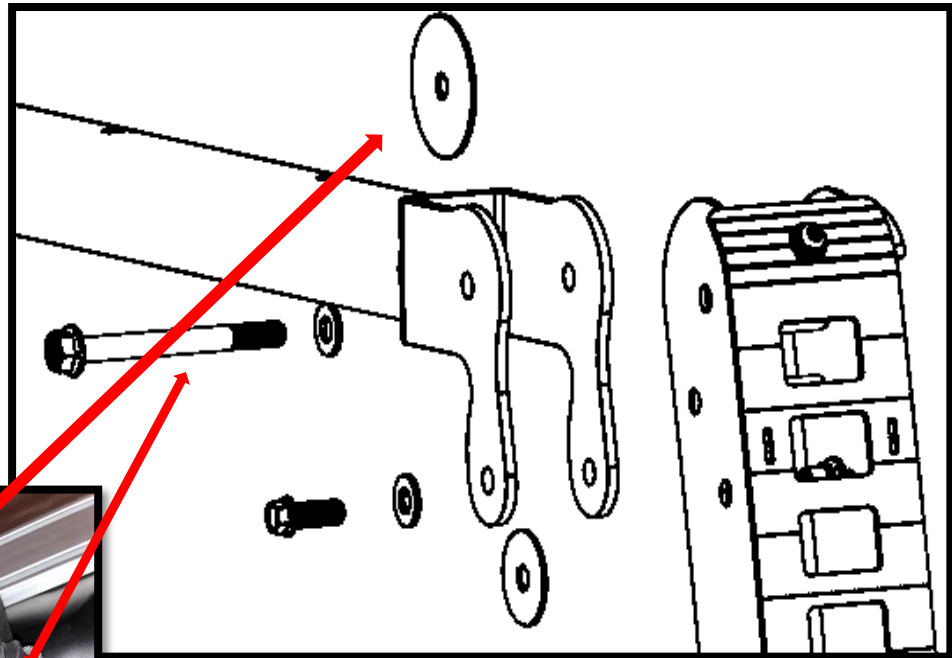

BACKSIDE VIEW

GO RHINO®

INSTALLATION INSTRUCTIONS

Step 2

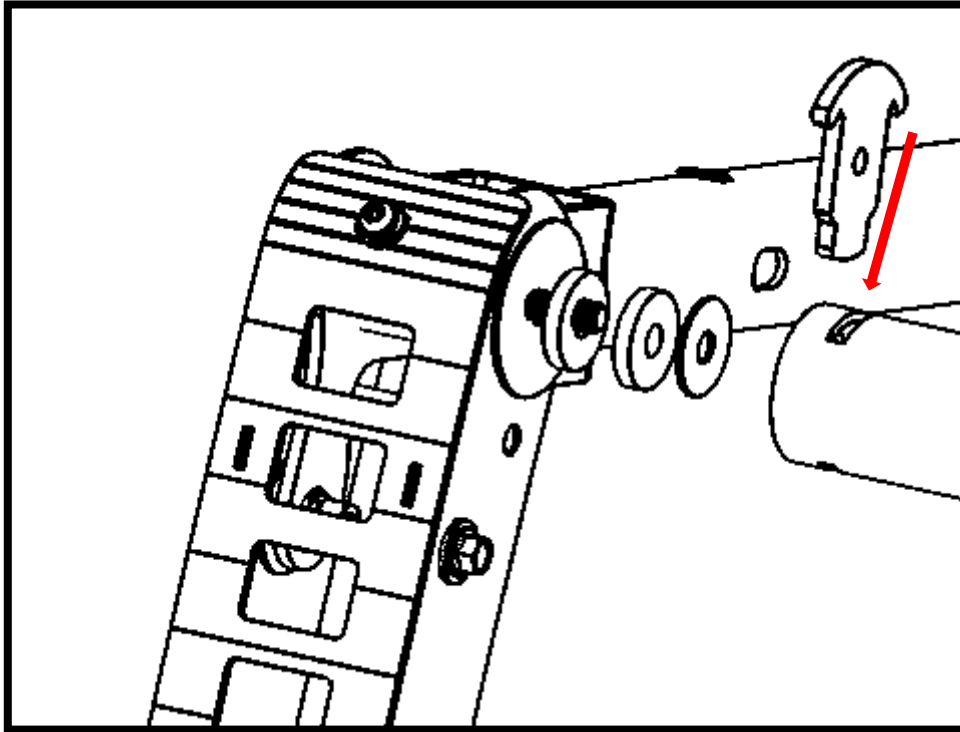

- Once the 3/8" bolt is run through, it should be only exposed thread. On the exposed thread, install one 2 1/4" vinyl washer, 2 qty 4 gauge spacers, and 1 qty 16 gauge spacer.
- Install threaded anchor plate on top connecting tubes (**single weep hole**). Connect upright to top connecting tubes and thread finger tight. Make sure the anchor plate all the way through the tube
- ****Identifying how the Top Tubes orientate. The tubes have a series of nutserts pressed into them. Once you identify top and bottom, the tube has to be positioned with the nutserts closest to the edge of the tube facing inwards. You can mock up a cross bar to make sure it facing the correct way. See page 8 for details.

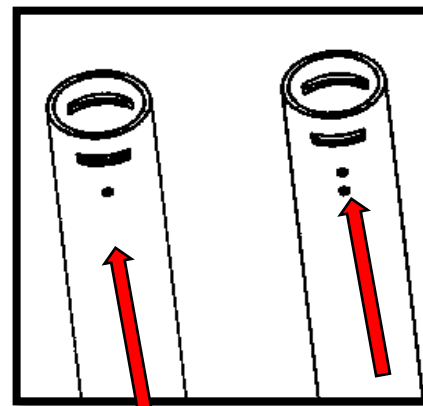
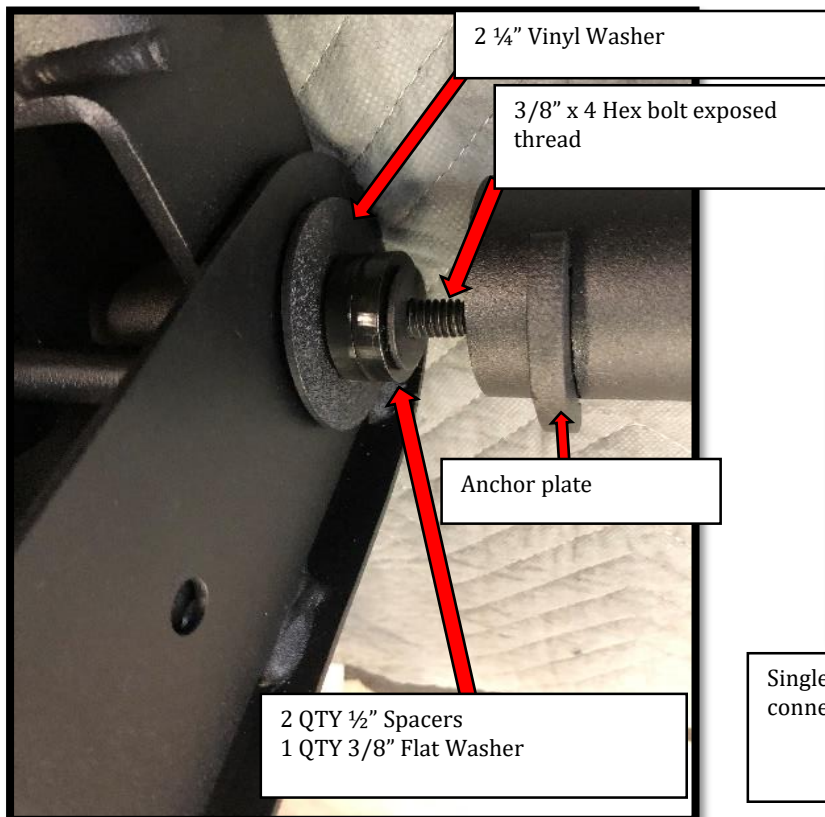

Single weep hole= top connecting tube

two weep holes= bottom connecting tube

GORRHINO®

INSTALLATION INSTRUCTIONS

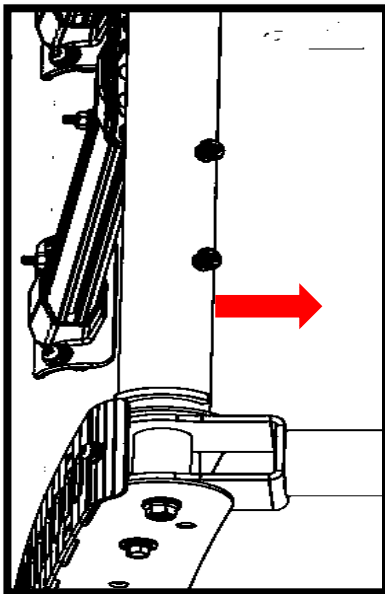
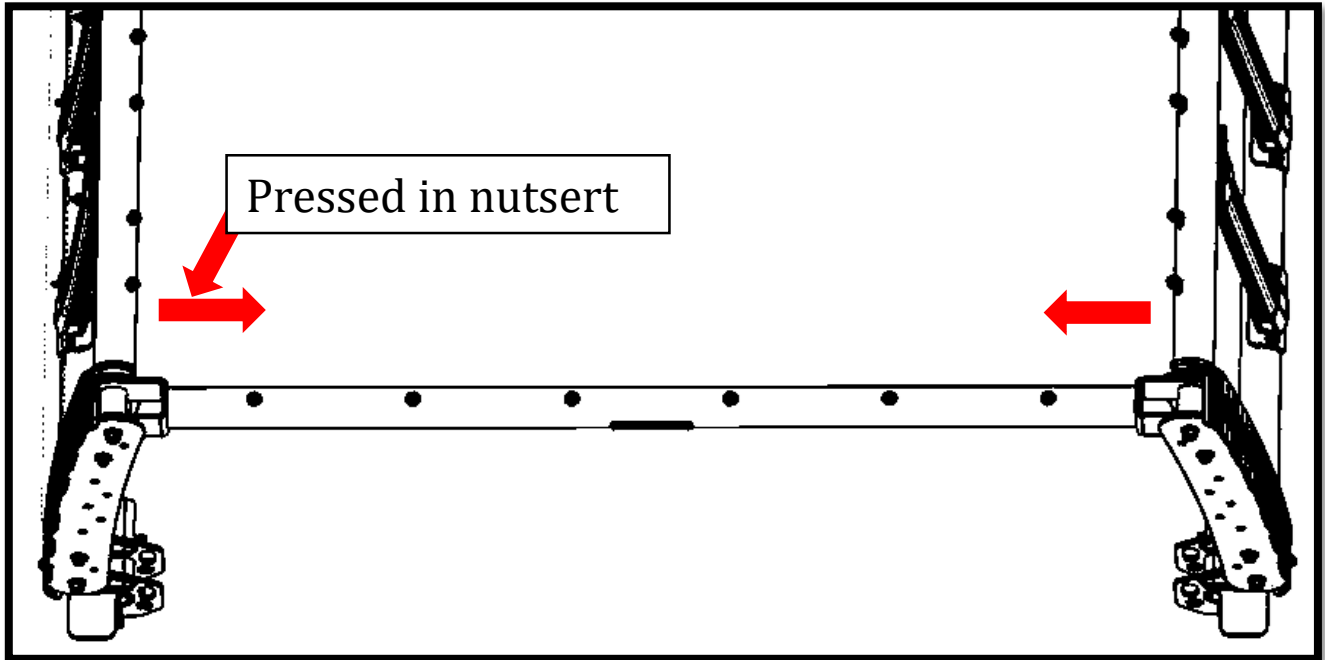

Once you identify the tubes, make sure the nutserts that are closest to the end of the tubes are facing inwards. If this step is skipped, the cross bars will not be able to be installed later in the installation process.

GORRHINO®

INSTALLATION INSTRUCTIONS

Step 3

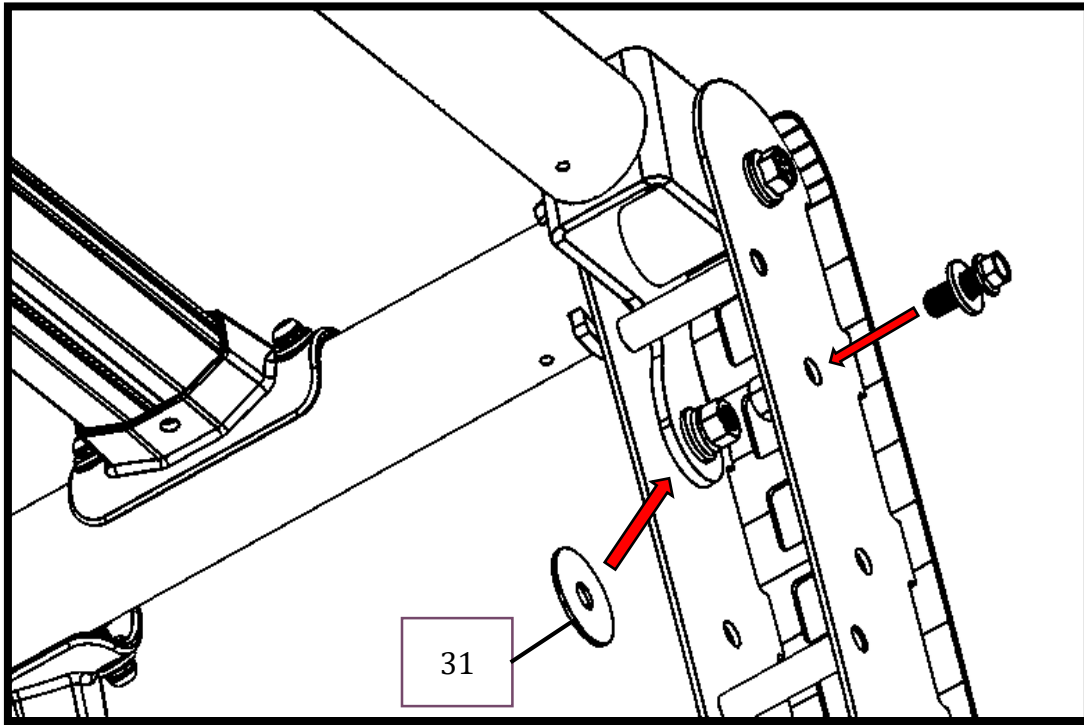

For the lower section of Upper Connecting Tube, each upright will take 2 qty 3/8x1" hex bolts, 4 qty 3/8" flat washers, 2 lock washers, 2 hex nuts. Leave finger tight and repeat process for the remaining three corners. Install the hex bolt from the outside of the upright with one flat washer. On the inside of the upright, you'll need to install the 1 1/2" vinyl spacers in between, then you can install one 3/8 flat washer, one 3/8 lock washer and one 3/8 hex nut. Repeat process for each upper corner.



Assembled top corner

GORRHINO®

INSTALLATION INSTRUCTIONS

Step 3

To assemble the bottom feet, you'll want to install the adhesive foam pad to the flat surface of the feet. Just like the top section, you'll need 3/8"x4" Hex bolt, 3/8" flat washer, 2 qty 2 1/4" vinyl washers, 2 qty 1 1/2" vinyl washers, 2 qty 1/4" spacer washers, 1 qty 3/8" flat washer. Identify what direction each foot orientates. Refer to image # to see the foot and upright orientates.

Install 3/8" x4" hex head bolt with 3/8" lock washer, 3/8 flat washer through the bottom hole of the upright. Before the bolt runs through, you will need to add 2 qty 2 1/4" Vinyl Washer in between (one per side) *****INSTALLATION TIP*** Use painters tape to hold the vinyl washer in place when assembling it.**

Install 3/8"x 1" hex bolt and 3/8" flat washer on the upper holes. Once assembled, install 3/8" flat washer, 3/8" lock washer and 3/8 hex nut. Repeat this process twice per bottom upright corner.

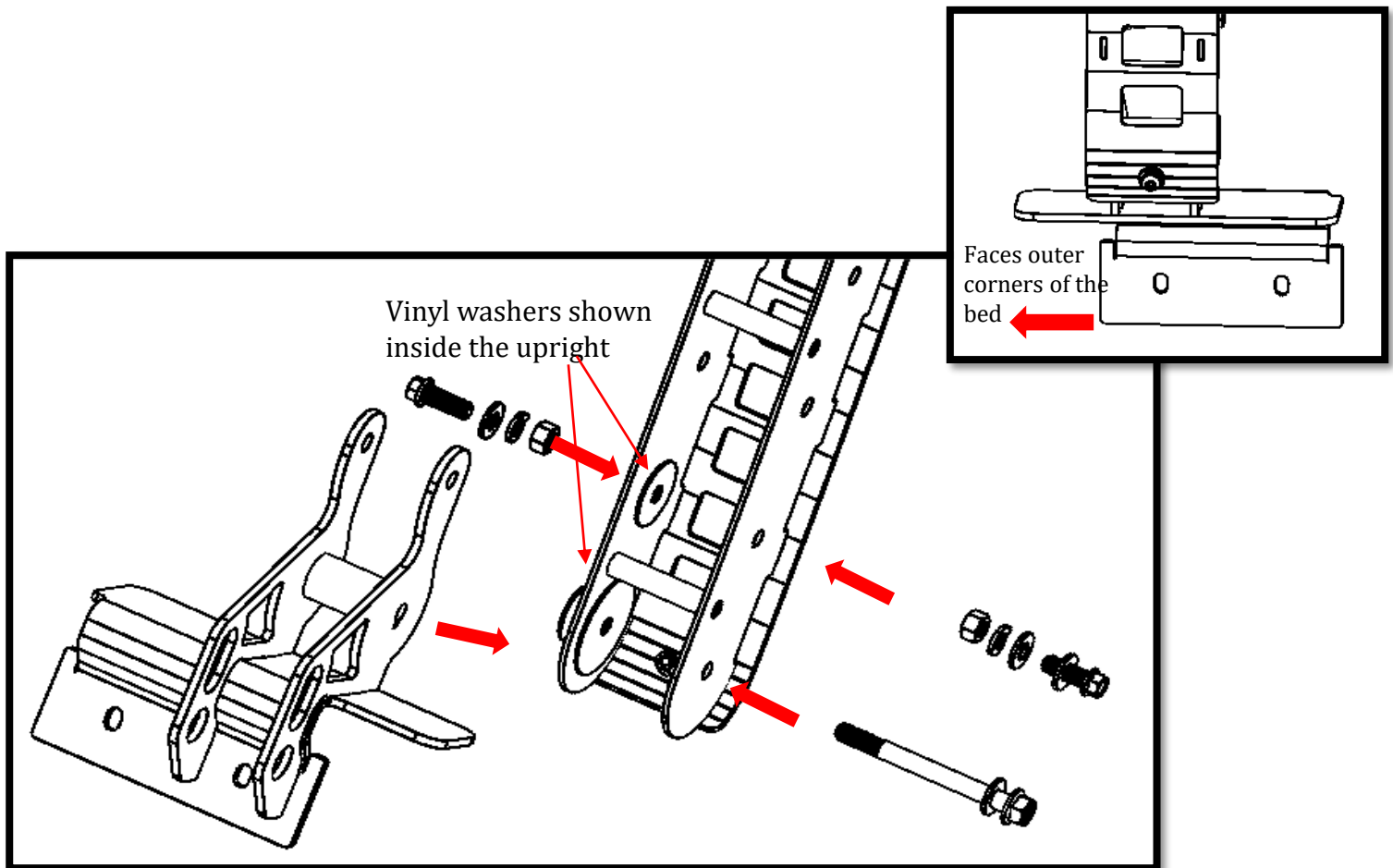

GO RHINO®

INSTALLATION INSTRUCTIONS

Step 4

Multi-Core Cross Bar Installation (long & short)

HARDWARE NEEDED	
QTY	ITEM
40	1/4"x1" Button Head Bolt
40	1/4" Flat Washer
40	1/4" Lock Washer

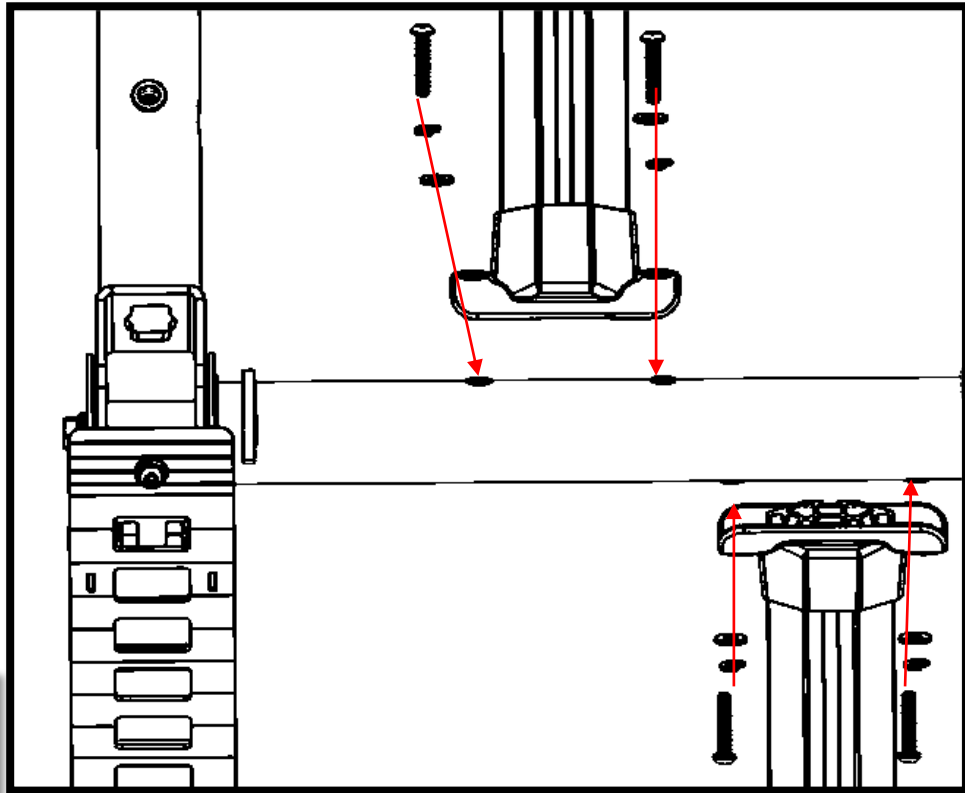

Install and seat each multi-core cross bar on the nutserts located on the connecting tubes. Long cross bars are installed on top, shorter cross bars are installed on the sides. Once installed, use 1/4" flat washer, 1/4" lock washer and 1/4" button head bolt to secure cross bar to the connecting tube (2qty per side). Follow the same steps for the remaining multi-core cross bars and leave finger tight.

GO RHINO®

INSTALLATION INSTRUCTIONS

Step 5

Accessory Moly Plate Installation.

HARDWARE NEEDED	
QTY	ITEM
6	¼ HEX HEAD BOLT
6	¼ FLAT WASHER
6	¼ HEX NUT

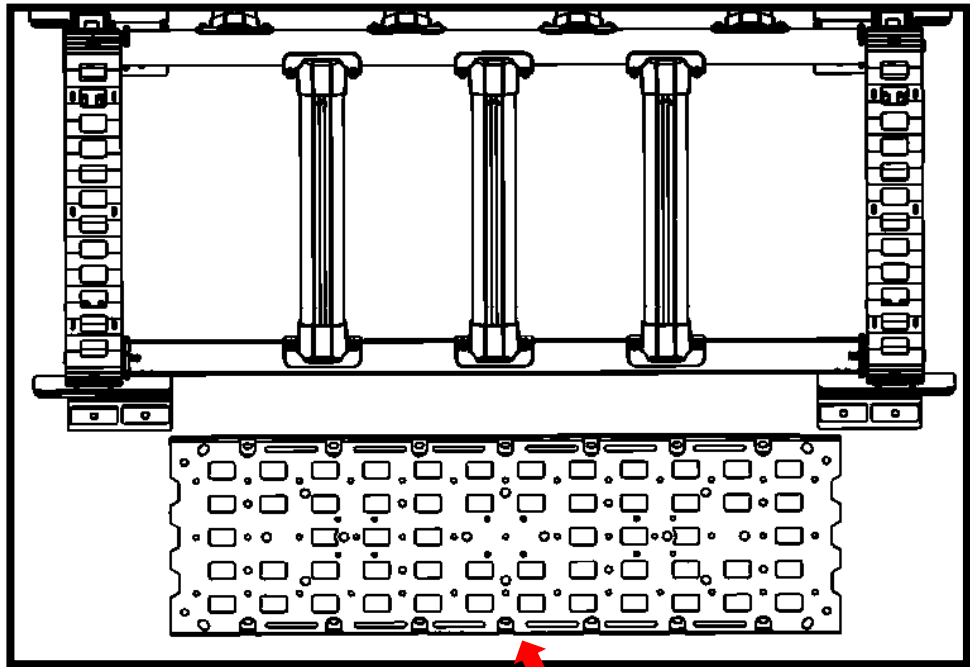

- The Accessory Moly Plate is optional to install. Due to the Xtreme Racks symmetrical design, the moly plate can be installed on either side of the Overland rack. Each side cross bar will need two hex bolts, two washers and two hex nuts. Introduce the hex bolt into the existing hole on the cross bar. Once all 6 hex bolts are on, install molly plate, fasten with flat washer and hex bolt



*** Installation Tip*** use painters tape to keep the bolt stationary and not sliding downwards during installation

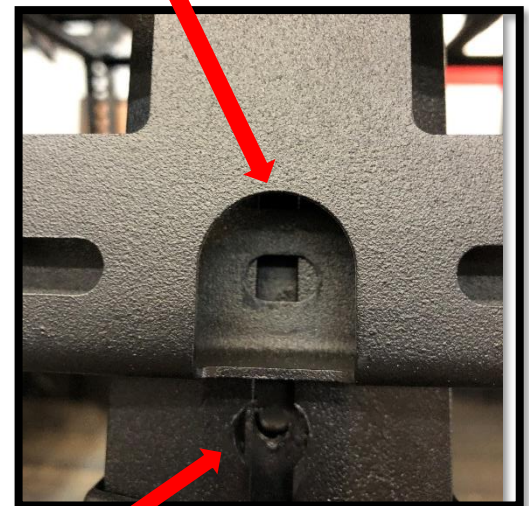

Introduce hex bolt through here.

GORRHINO®

INSTALLATION INSTRUCTIONS

Step 5

Installation on vehicles equipped with Mopar Bed Track System

*******Before you begin to install the threaded bolt plates onto Mopar Track System, you will need to remove any installed adjustable tie down cleats. Refer to your owners manual on removal process*******

HARDWARE NEEDED	
QTY	ITEM
8	Bed Track Mounting Plates
8	5/16 x 1 1/2" Carriage Bolts

With tie down cleats removed, install Bed Track Mounting Plate with 5/16" Carriage Bolt bolt plates onto bed track system, the opening is located at the front of the bed. Each side will use 4 bolt plate and carriage bolts.

*****if you are planning on reusing your tie down cleats, you will need to install them after the first threaded bolt plate is installed. You will not be able to reinstall them once the rack is on*******

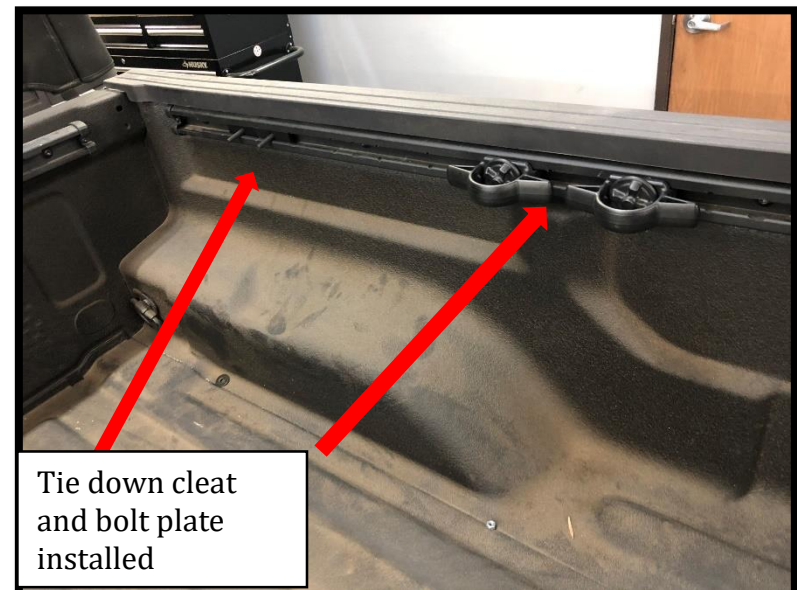

GO RHINO®

INSTALLATION INSTRUCTIONS

Step 5

With assistance, place rack system on to bed rail and align the rack mount with the bolt plates inside the Mopar track system. Bolt plates should be shown as exposed studs. Fasten each foot with 2 (qty) 5/16 Flat Washer, 5/16 Lock Washer and 5/16 Hex Nut. Repeat process for each foot.



HARDWARE NEEDED	
QTY	ITEM
8	5/16 Flat Washers
8	5/16 Lock Washers
8	5/16 Hex Nut

GO RHINO[®]

INSTALLATION INSTRUCTIONS

Step 6

Installation on vehicles equipped without Mopar Bed Track System

Use the provided bed rail clamp and install 5/16" carriage bolt from the backside. The teeth on the clamp should rest underneath the bed rail. Once the threads are exposed, use 5/16" flat washer, 5/16 lock washer, and 5/16 hex nut to secure the clamp. Repeat process for each corner.



HARDWARE NEEDED	
QTY	ITEM
8	5/16 Flat Washers
8	5/16 Lock Washers
8	5/16 Hex Nut
4	Bed Rail Clamp



GORRHINO®

INSTALLATION INSTRUCTIONS

Step 6

Once the feet are secured to the rail, adjust the rack to make it square with the cab and fasten all remaining loose hardware securely. Be sure to inspect all the hardware periodically and fasten as needed.

