

GO RHINO®

INSTALLATION INSTRUCTIONS

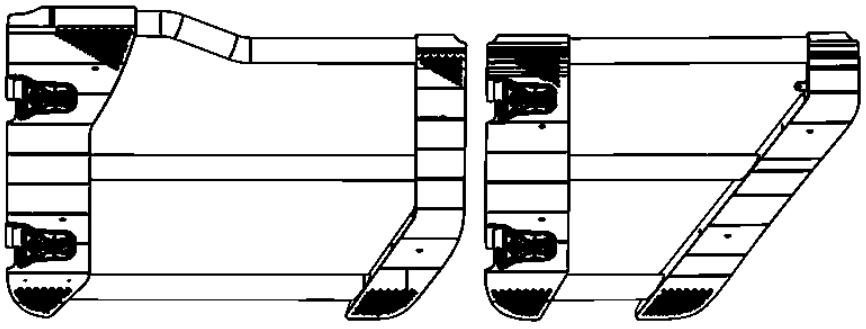

PART NO.

- 572501 Front Door Pair
- 572502 Rear Door Pair
- 572601 Front Door Pair
- 572602 Rear Door Pair

PRODUCT DESCRIPTION:

- Tube Door Replacement Set (Front and Rear) - Jeep Wrangler JKU.
- Tube Door Replacement Set (Front and Rear) - Jeep Wrangler JLU.

PRODUCT SAFETY & LEGAL DISCLAIMER

- **IMPORTANT READ ALL INSTRUCTIONS CAREFULLY BEFORE INSTALLING, FAILURE TO DO SO MAY CAUSE PERSONAL INJURY OR DAMAGE TO PRODUCT AND/OR PROPERTY.**
- **Review the product package and contents prior to beginning the installation.** Take care when opening the packaging and removing items. If a return is needed you will want to return the product in its original packaging if possible.
- This instruction guide is provided as a GENERAL installation guide, some vehicles vary dimensionally and may require additional steps.
- Test fit the product on the vehicle prior to any third party modifications and or finishing. The manufacturer and/or distributors do not accept responsibility for third party charges, labor and or third part replacement modifications. Some modifications may void the factory warranty.
- Exercise due-diligence when installing this product. The manufacturer and distributors of this product do not accept any responsibility for vehicle damage or personal injury resulting from the installation of this product. Careless installation and operation can result in serious injury or equipment damage.
- This product is for general off-road use. All liability for installation and use rests with the owner/operator.
- **INSTALLER:** Once installation is complete, please return this guide along with other documentation included in this product back to the consumer for future reference. The manufacturer/distributors of this product do not guarantee this particular version will be available at a later date.



INSTALLATION INSTRUCTIONS

INJURY HAZARD

Please complete a shop and tool inspection prior to beginning the installation.

- Always make sure you have a clean, dry and well lit work area.
- Always remove jewelry, loose fitting clothing and wear protective gloves and eye protection.
- Always use extreme caution when jacking or raising a vehicle for work. Set the emergency brake and use tire/wheel blocks and jack stands. Refer to the vehicle manufacturer hand book. Utilize the vehicle manufacturers designated lifting points.
- Always use appropriate and adequate care in lifting parts during disassembly and installation. Seek help in lifting heavy or large items into place. Utilize jacks and or lifting devices when available.
- Always insure products are secure during disassembly and installation.
- Always wear eye protection and take steps to protect any exposed skin during the installations. Drilling, cutting and grinding plastic and metal may create flying particles that can cause injury.
- Always use extreme caution when drilling, cutting and or grinding on a vehicle. Thoroughly inspect the area to be drilled, on both sides of material, prior to modification and relocate any objects that may become damaged.
- Always assemble and tighten all fasteners per the installation instructions.
- Always route electrical cables carefully. Avoid moving parts, parts that may become hot and rough or sharp edges.
- Always insulate and protect all exposed wiring and electrical connections.

MAINTENANCE AND CARE

- Always perform regular inspections and maintenance on mounts and related fasteners.
- Periodically check and tighten all fasteners.
- Stripped, fractured, or bent fasteners must be replaced.
- After washing the vehicle make sure to fully dry all surfaces.
- In areas with cold temperatures make sure to wash the product often to remove harmful materials used on road ways.
- Never use abrasive cleaners or polish compounds. Clean with a gentle soap and water. If you use wax use a non-abrasive automotive wax such as pure carnauba wax.

WARNING

Some products have been designed to work together with factory rear sensor systems, factory forward facing sensor systems and factory air bags.

- Installation of some of these products may alter the factory sensor system performance.
- Factory sensors may read shackles or hooks protruding from the fairlead and or tow hooks.
- All sensor testing is completed by Go Rhino Products and or third party testing labs on modified vehicles.
- Sensor sensitivity, factory sensor housing, orientation, and operating conditions are all variables that will influence functionality of the sensors.
- Installation of some product may effect the factory air bag systems.
- Some products allow the use of third party products such as winches, shackles, hooks, etc. Follow the respective manufacturers operating instructions for use with our products.
- Make sure to fully understand the product, it's intended use and operation prior to use.
- Above all... be safe!

GO RHINO®

INSTALLATION INSTRUCTIONS

PARTS INCLUDED IN THIS LIST:

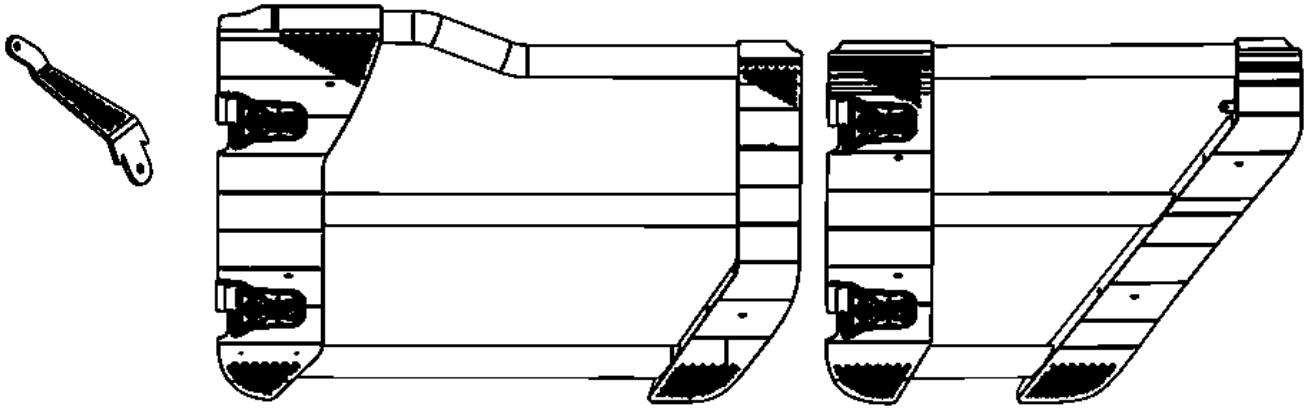

| PART | QTY | DESCRIPTION | HARDWARE | QTY | DESCRIPTION |
|------|-----|------------------------------|----------|-----|--------------------|
| 1 | 1 | FRONT DOORS (PAIR) | 1 | 2 | 3/8" X 1" HEX BOLT |
| 2 | 1 | REAR DOORS (PAIR) | 2 | 2 | 3/8" HEX NUT |
| 3 | 1 | DOOR MIRROR BRACKET (PAIR) | 3 | 2 | 3/8" LOCK WASHER |
| 4 | 1 | DOOR CHECK STRAPS (SET OF 4) | 4 | 2 | 3/8" FLAT WASHER |
| 5 | 2 | MIRROR (not pictured) | | | |

Go Rhino recommends you, the installer, read this installation instruction manual from front to back before installing the product.

TOOLS NEEDED FOR INSTALLATION:

- 5mm Hex key
- 13mm wrench or socket.
- 9/16 wrench or socket
- 10mm wrench

ESTIMATED TIME FOR INSTALLATION:

1.5 Hours

GO RHINO®

INSTALLATION INSTRUCTIONS

STEP # 1

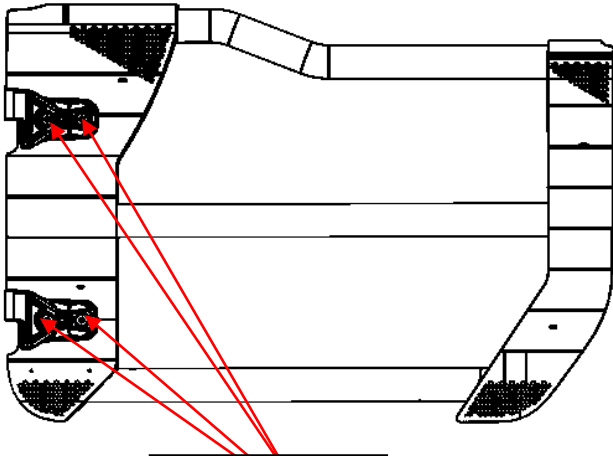

Loosen hinge fasteners

Start by removing your vehicle's factory doors. Refer to your vehicles owner manual. Retain the factory door retaining nuts for use with your tube doors.

Before you install the tube doors, start by locating the hinge fasteners. Loosen the fasteners on the upper and lower hinges slightly with a 5mm Hex key and a 13mm wrench or socket.

With assistance, align the hinge pins with the factory door hinges of your vehicle and gently lower the doors onto the hinges

Install the factory door retention nuts with a T50 Torx but do not fully tighten at this time.

With a 10 mm wrench loosen the jam nuts on the door stop and thread the door stop in as far as it will go.



factory door retention nuts

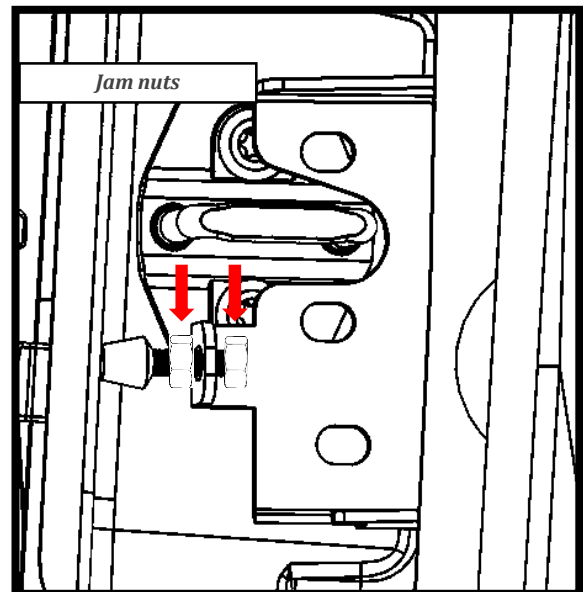

GO RHINO®

INSTALLATION INSTRUCTIONS

STEP # 2

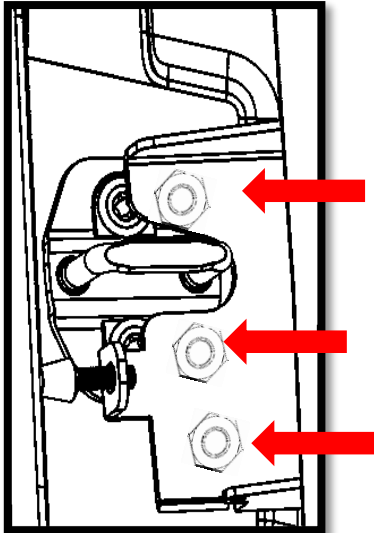

Next, close the door and align the latch on the vehicle striker pin. Push the door onto the striker until the latch fully engages with two clicks. The latch that is equipped with your tube doors are two stage latches; please make sure that both stages are engaging before proceeding.

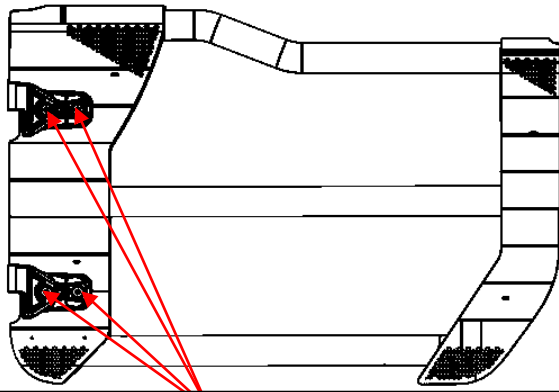

If the latch is not engaging properly you may need to loosen the latch with a 13mm wrench and a T40 torx bit. Adjust the position of the latch as needed. Tighten all fasteners after the adjustment is complete.

While the doors are still closed and the latch is engaged, tighten the hinge fasteners with a 5mm hex key and 13mm wrench

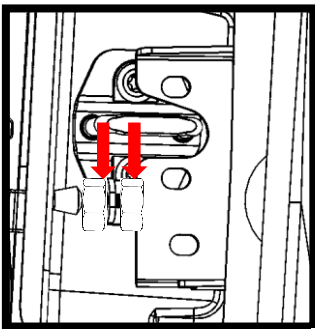

Adjust the door stop out until the rubber end firmly makes contact with the body of the vehicle. Tighten both the jam nuts with a 10mm wrench. Depending on your adjustment the jam nuts may be on opposite sides of the bracket as shown or both nuts may be installed on the inside of the bracket to provide proper clearance



GO RHINO®

INSTALLATION INSTRUCTIONS

STEP # 3

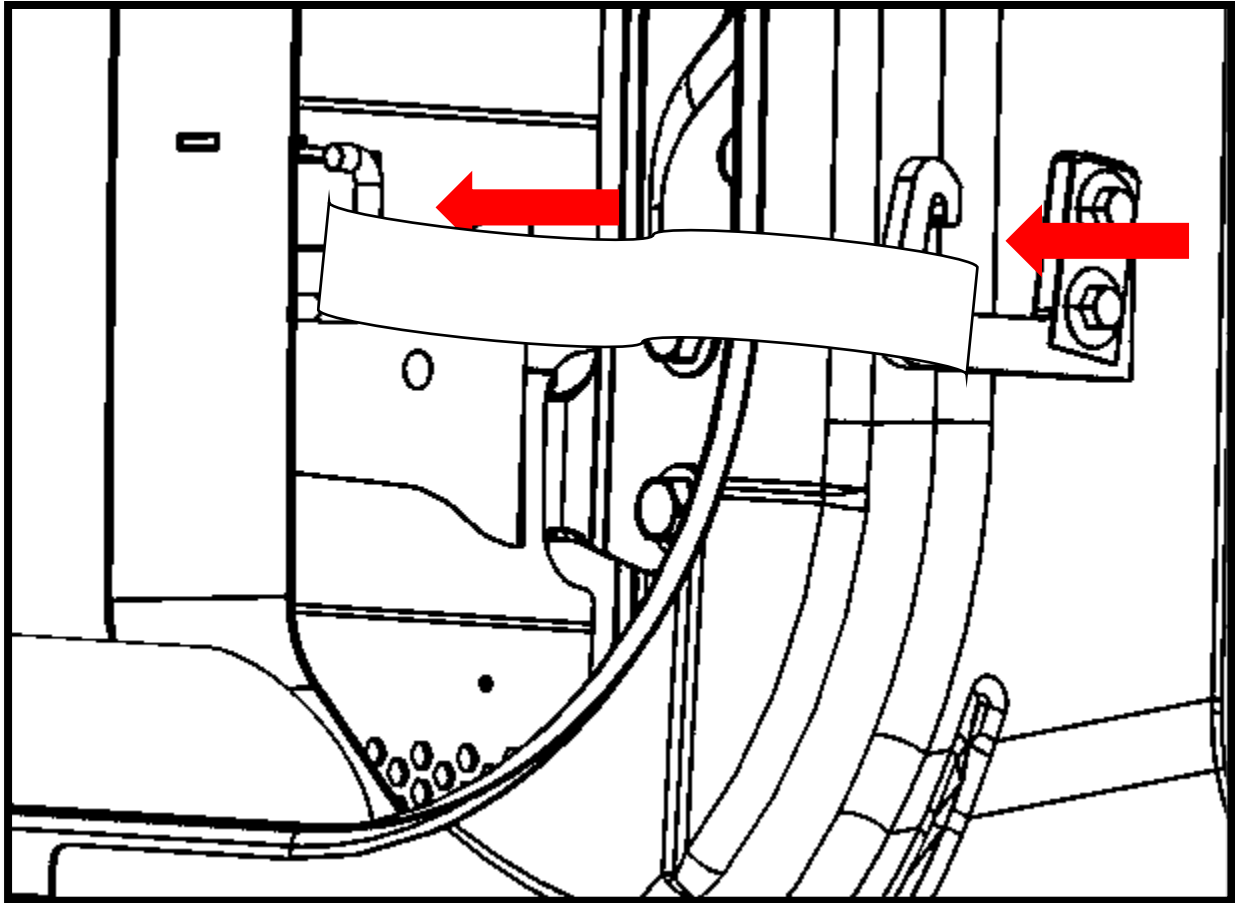

Adjust to your desired distance

Open the door by lifting up on the latch knob on the inside of the door. Gently swing the door open and loop the door check strap over the hook on the inside of the door. Attach the other end of the door check to the factory hook on the inside of the vehicle

The check the straps have multiple positions to allow for adjustment. Adjust the position of the straps so that the door will not open too far and come in contact with the body of the vehicle. This could cause damage to the door of the vehicle

Caution: IF DOORS SWING OPEN TOO FAR YOU CAN DAMAGE THE BODY OF THE VEHICLE. PLEASE USE CAUTION

GORRHINO®

INSTALLATION INSTRUCTIONS

STEP # 4

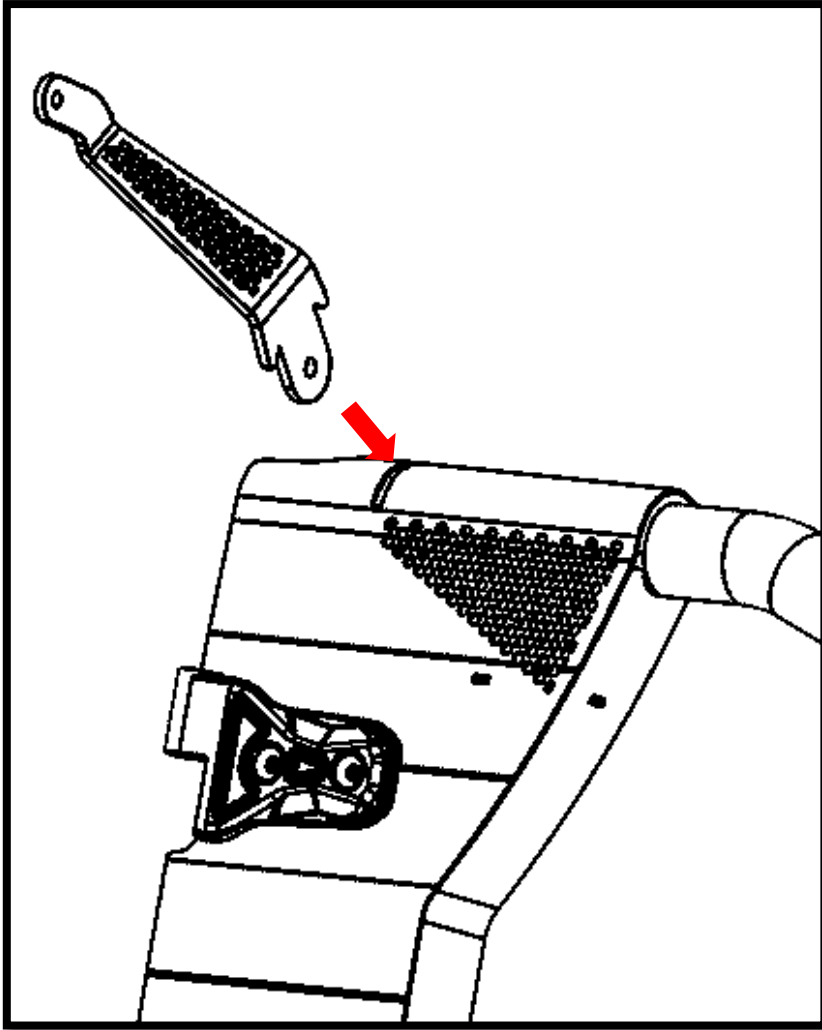

Install mirror bracket onto front door. Insert the bracket into the slot located on the top side and match it with the hole bracket located on the inside of the door. Fasten down using 3/8" x 1" hex bolt, 3/8" flat washer, 3/8" lock washer and 3/8" nut. Repeat process for both sides.

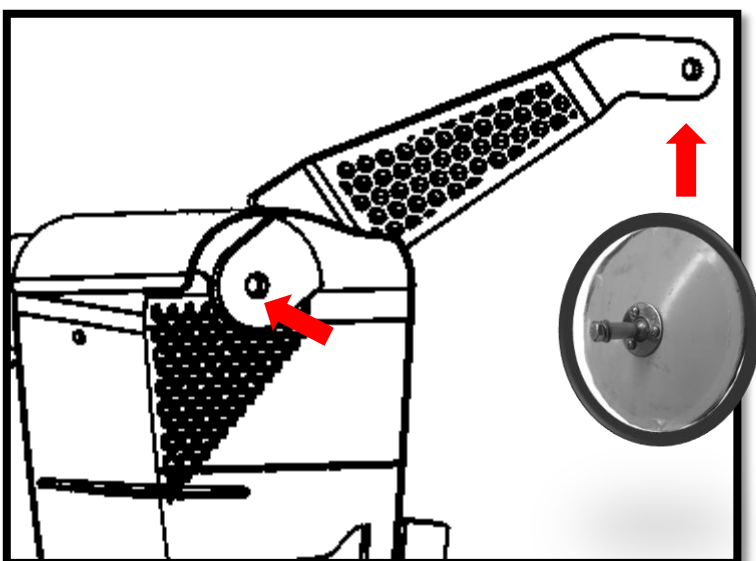

Install mirror onto the mirror bracket. Use the preassembled hardware that came with each mirror (5/16" flat washer, 5/16" lock washer, and 5/16" x 3/4" bolt). Repeat process for both sides.