

GO RHINO®

INSTALLATION INSTRUCTIONS

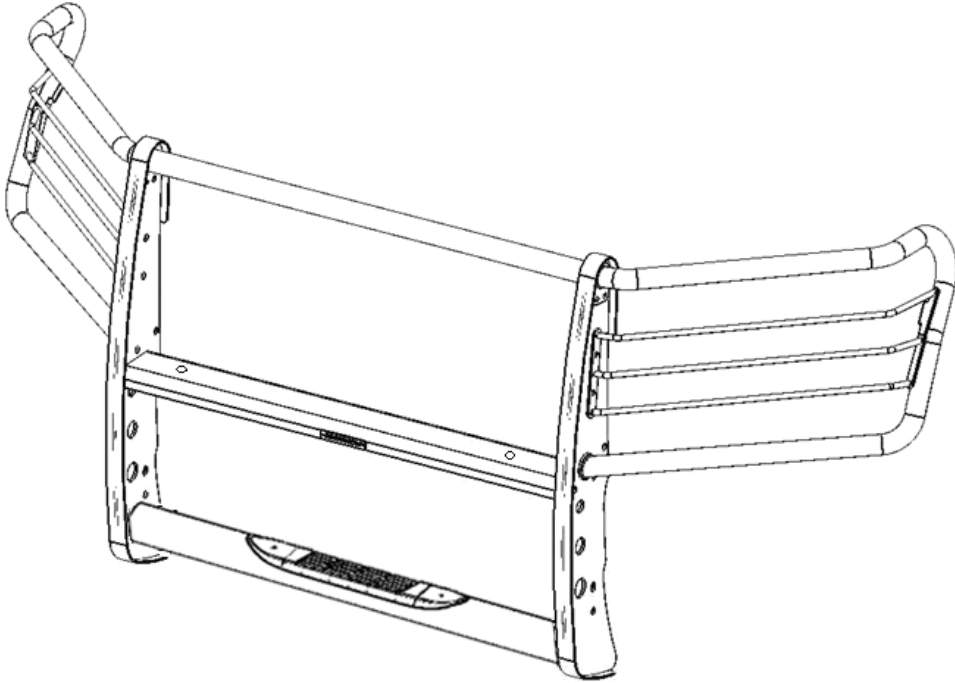

PART NO.

- 3176M

PRODUCT DESCRIPTION:

- 3000 Series Step Guard

APPLICATION:

- Chevrolet Silverado 1500 (Excludes models with Safety Package- Safety Package II)

PRODUCT SAFETY & LEGAL DISCLAIMER

- **IMPORTANT READ ALL INSTRUCTIONS CAREFULLY BEFORE INSTALLING, FAILURE TO DO SO MAY CAUSE PERSONAL INJURY OR DAMAGE TO PRODUCT AND/OR PROPERTY.**
- **Review the product package and contents prior to beginning the installation.** Take care when opening the packaging and removing items. If a return is needed you will want to return the product in its original packaging if possible.
- This instruction guide is provided as a GENERAL installation guide, some vehicles vary dimensionally and may require additional steps.
- Test fit the product on the vehicle prior to any third party modifications and or finishing. The manufacturer and/or distributors do not accept responsibility for third party charges, labor and or third part replacement modifications. Some modifications may void the factory warranty.
- Exercise due-diligence when installing this product. The manufacturer and distributors of this product do not accept any responsibility for vehicle damage or personal injury resulting from the installation of this product. Careless installation and operation can result in serious injury or equipment damage.
- This product is for general off-road use. All liability for installation and use rests with the owner/operator.
- **INSTALLER:** Once installation is complete, please return this guide along with other documentation included in this product back to the consumer for future reference. The manufacturer/distributors of this product do not guarantee this particular version will be available at a later date.



INSTALLATION INSTRUCTIONS

INJURY HAZARD

Please complete a shop and tool inspection prior to beginning the installation.

- Always make sure you have a clean, dry and well lit work area.
- Always remove jewelry, loose fitting clothing and wear protective gloves and eye protection.
- Always use extreme caution when jacking or raising a vehicle for work. Set the emergency brake and use tire/wheel blocks and jack stands. Refer to the vehicle manufacturer hand book. Utilize the vehicle manufacturers designated lifting points.
- Always use appropriate and adequate care in lifting parts during disassembly and installation. Seek help in lifting heavy or large items into place. Utilize jacks and or lifting devices when available.
- Always insure products are secure during disassembly and installation.
- Always wear eye protection and take steps to protect any exposed skin during the installations. Drilling, cutting and grinding plastic and metal may create flying particles that can cause injury.
- Always use extreme caution when drilling, cutting and or grinding on a vehicle. Thoroughly inspect the area to be drilled, on both sides of material, prior to modification and relocate any objects that may become damaged.
- Always assemble and tighten all fasteners per the installation instructions.
- Always route electrical cables carefully. Avoid moving parts, parts that may become hot and rough or sharp edges.
- Always insulate and protect all exposed wiring and electrical connections.

MAINTENANCE AND CARE

- Always perform regular inspections and maintenance on mounts and related fasteners.
- Periodically check and tighten all fasteners.
- Stripped, fractured, or bent fasteners must be replaced.
- After washing the vehicle make sure to fully dry all surfaces.
- In areas with cold temperatures make sure to wash the product often to remove harmful materials used on road ways.
- Never use abrasive cleaners or polish compounds. Clean with a gentle soap and water. If you use wax use a non-abrasive automotive wax such as pure carnauba wax.

WARNING

Some products have been designed to work together with factory rear sensor systems, factory forward facing sensor systems and factory air bags.

- Installation of some of these products may alter the factory sensor system performance.
- Factory sensors may read shackles or hooks protruding from the fairlead and or tow hooks.
- All sensor testing is completed by Go Rhino Products and or third party testing labs on modified vehicles.
- Sensor sensitivity, factory sensor housing, orientation, and operating conditions are all variables that will influence functionality of the sensors.
- Installation of some product may effect the factory air bag systems.
- Some products allow the use of third party products such as winches, shackles, hooks, etc. Follow the respective manufacturers operating instructions for use with our products.
- Make sure to fully understand the product, it's intended use and operation prior to use.
- Above all... be safe!

GO RHINO®

INSTALLATION INSTRUCTIONS

PARTS INCLUDED IN THIS LIST:

ITEM	QTY.	PART NUMBER	DESCRIPTION	TORQUE	ITEM	QTY.	PART NUMBER	DESCRIPTION	TORQUE
A	2	AST-T835G4	1/4" X 3/4" Button Head Bolt	8 ft.-lbs.	J	6	AST-T826G4	1/2" x 1 1/2" Hex Bolt	75 ft-lbs
B	8	AST-T187G4	5/16" x 1" Button Head Bolt	16 ft.-lbs.	K	10	AST-RPR05G4	1/2" Lock Washer	
C	8	AST-RP16G4	5/16" Flat Washer		L	10	AST-RP115G4	1/2" Flat Washer	
D	8	AST-TU14G4	5/16" Nylon Lock Nut		M	6	AST-TU120G4	1/2" Hex Nut	
E	4	AST-T861G4	3/8" x 1 1/4" Hex Bolt	31 ft-lbs	N	4		M12 T-Bolt	
F	8	AST-T194G4	3/8" x 1 1/4" Button Head Bolt	29 ft-lbs	O	4	AST-TU322G4	M12 Hex Nut	
G	12	AST-RPR07G4	3/8" Lock Washer		P	4	ASH-E57	Vinyl Gasket	
H	4	AST-RP120G4	3/8" Flat washer		Q	1	AST-TU68	Bolt Guide	
I	4	AST-TU105G4	3/8" Hex Nut						
OEM TOW HOOK BOLTS / TORQUE 92 ft-lbs									

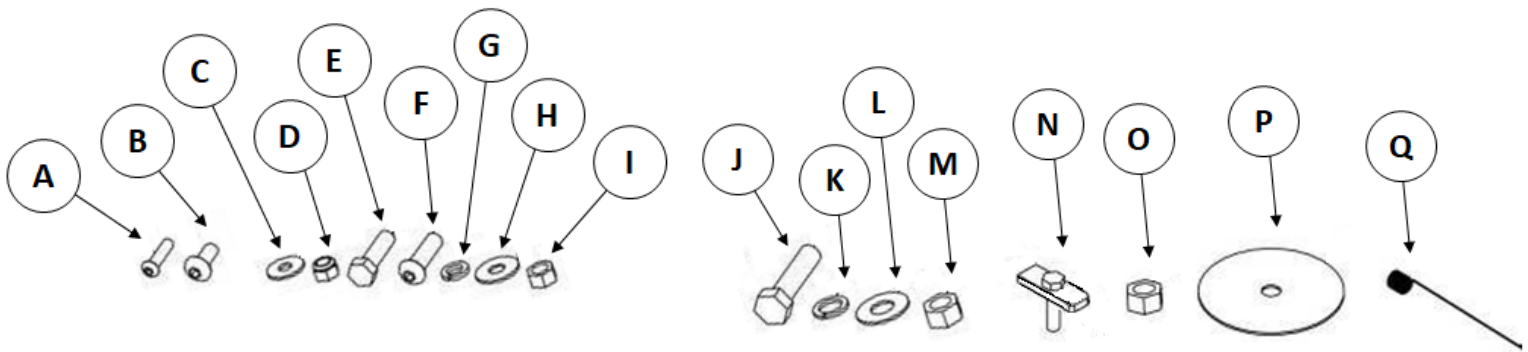

Go Rhino recommends you, the installer, read this installation instruction manual from front to back before installing the product.

TOOLS NEEDED FOR INSTALLATION:

- 10mm, 13mm, 18mm, 1/2", 9/16" & 3/4" Sockets
- 13mm, 18mm, 1/2", 9/16" & 3/4" Wrenches
- Ratchet, Ratchet Extensions & Swivel Joint Adapter
- T-10 Torx Bit Socket & 5/32", 3/16" & 7/32" Hex Bit Socket
- Utility Knife

ESTIMATED TIME FOR INSTALLATION:

90 min

GO RHINO®

INSTALLATION INSTRUCTIONS

PARTS INCLUDED IN THIS LIST:

ITEM	QTY.	PART NUMBER	DESCRIPTION	ITEM	QTY.	PART NUMBER	DESCRIPTION
1	1		Top Tube	7	1		Headlight Protector (Passenger)
2	1		Center Channel	8	1		Headlight Protector (Driver)
3	1		Step Tube	9	1		Upper Bracket (Passenger)
4	2		Side Plate	10	1		Upper Bracket (Driver)
5	1		Brush Guard (Passenger)	11	1		Lower Bracket (Passenger)
6	1		Brush Guard (Driver)	12	1		Lower Bracket (Driver)

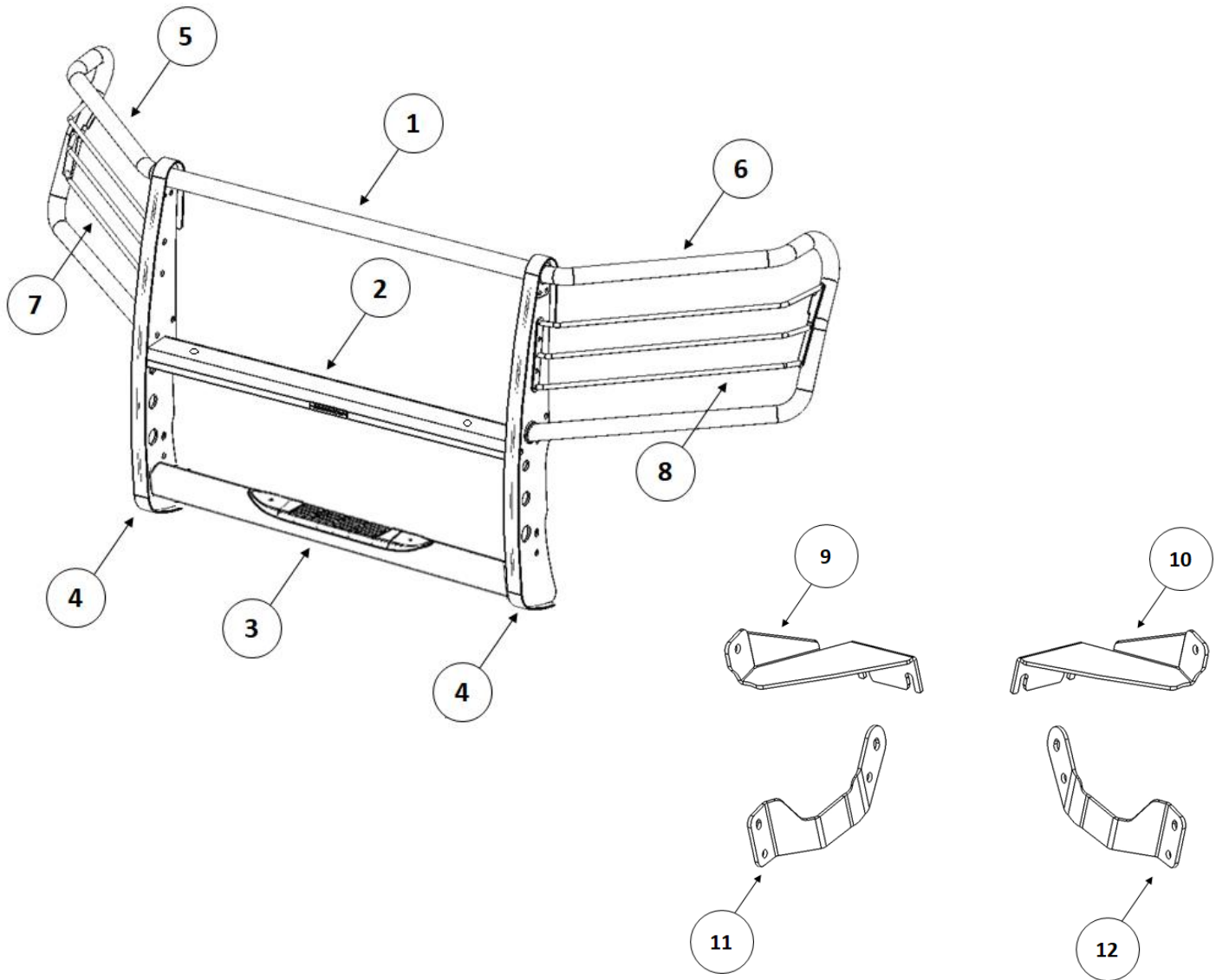



INSTALLATION INSTRUCTIONS

Step-1 Position the grille guard side plates with the front edge down and the top and bottom step tube between the side plates.

Step-2 Attach the top tube to the side plates using (2) 3/8" X 1 1/4" hex bolts and (2) 3/8" lock washers. Do not tighten.

Step-3 Attach the step tube to the side plates using (4) 3/8" X 1 1/4" button head bolts and (4) 3/8" lock washers. Do not tighten.

Step-4 Position the center plate between the grille guard side plates, with the slotted mounting holes in the center plate down. Attach the center plate to the side plates using (4) 3/8" X 1 1/4" button head bolts, (4) 3/8" flat washers, (4) 3/8" lock washers and (4) 3/8" hex nuts. Do not tighten.

Step-5 Position the driver side brush guard up to the grille guard assembly. Loosely attach the bottom of the brush guard to the grille guard side plate using (1) 3/8" X 1 1/4" hex bolt and (1) 3/8" lock washer. Attach the top of the brush guard to the side plate using (2) 5/16" X 1" button head bolts, (2) 5/16" flat washers and (2) 5/16" lock nuts. Do not tighten. Repeat for the passenger side brush guard.

Step-6 Attach the driver side headlight protector to the brush guard using (1) 1/4" x 3/4" button head bolt, and the opposite end to the side plate using (2) 5/16" x 1" button head bolts, (2) 5/16" flat washers and (2) 5/16" lock nuts. Repeat for the passenger side headlight protector. Align the grille and brush guard assembly, and tighten all nuts and bolts.

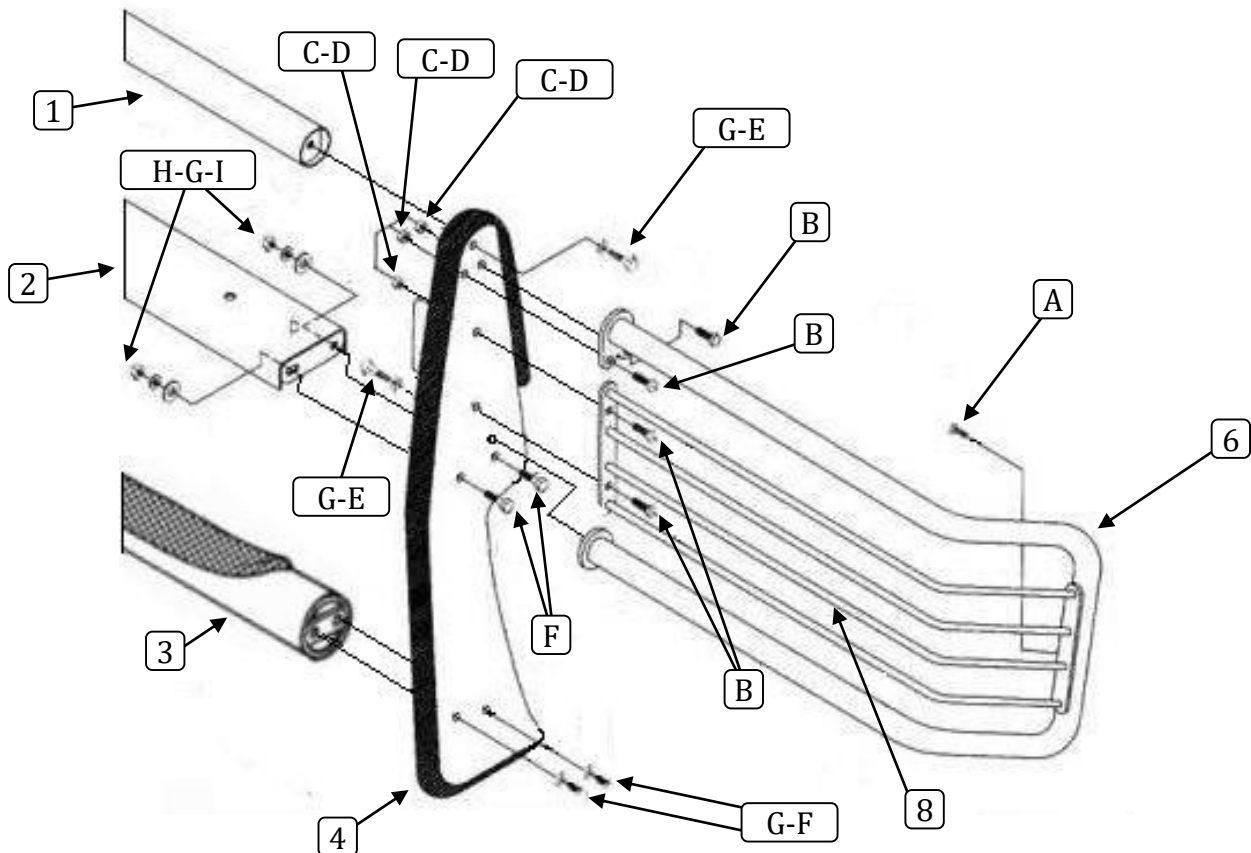

GO RHINO®

INSTALLATION INSTRUCTIONS

Vehicles equipped with factory tow hooks:

Step-1 From underneath the vehicle, remove (1) nut and (2) bolts securing the driver side tow hook to the frame rail using an 18mm socket and 18mm wrench, (Fig 1 & 2).

Step-2 Remove the tow hook by pulling the tow hook out of the frame from the front of the bumper, then remove the foam tow hook access cover from behind the bumper. Note: the foam access cover will not be reinstalled.

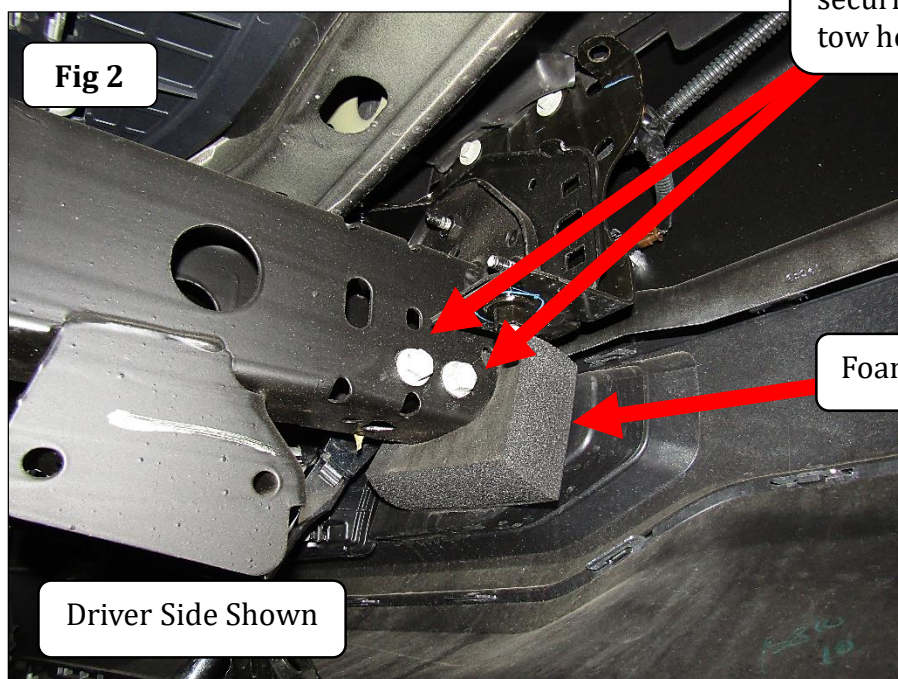
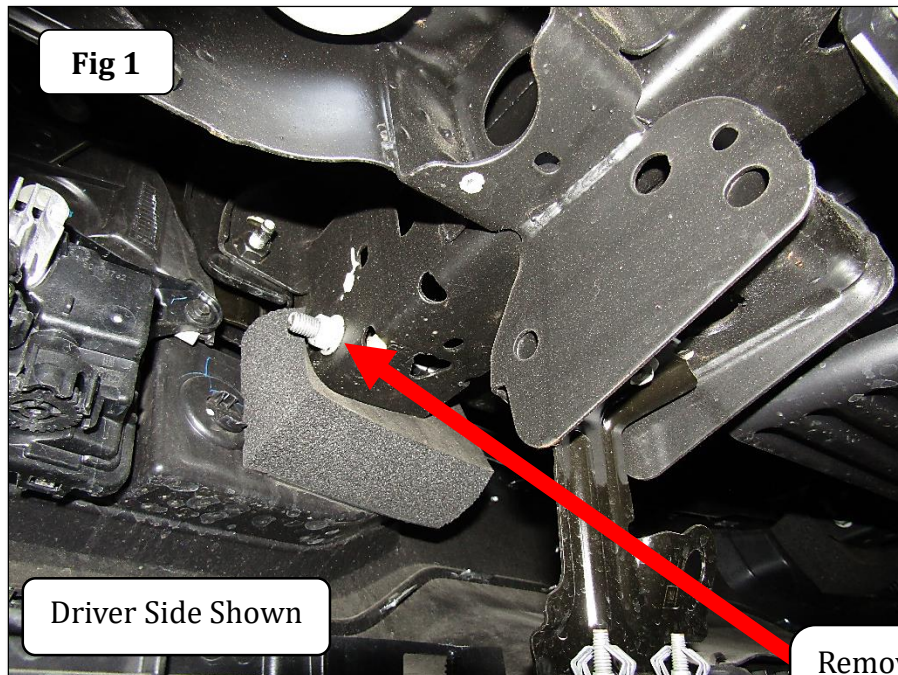

GO RHINO®

INSTALLATION INSTRUCTIONS

Vehicles equipped with factory tow hooks:

Step-3 Cut and remove the area of the bumper lower cover to clear the mounting bracket, (Fig 3). Repeat step 1 through 3 for the passenger side.

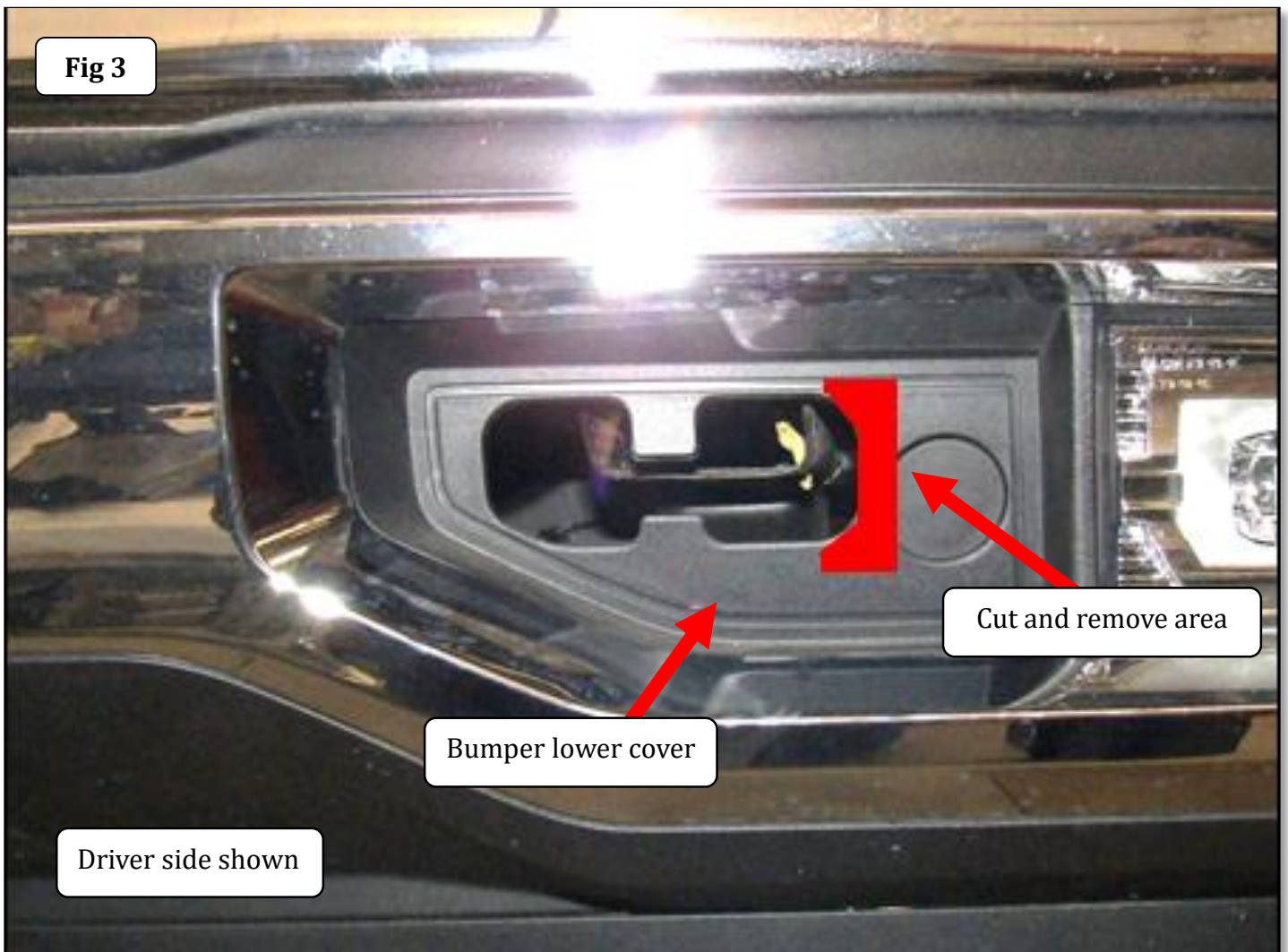

GO RHINO®

INSTALLATION INSTRUCTIONS

Vehicles equipped with factory tow hooks:

Step-4 From the opening at the end of the driver side frame, position (1) M12 t-bolt inside the frame with the bolt extending out through the obround shape hole on the side of the frame. Install (1) vinyl gasket on the bolt to keep the t-bolt from falling back into the frame. Note: To ease installation use the supplied pull wire to fish the t-bolt from the opening and out through hole in the frame.

Step-5 From the front of the bumper position the driver side mounting bracket through the opening in the bumper lower cover and up to the side of the frame, align the upper hole in the mounting bracket with the M12 t-bolt, then secure the mounting bracket to the side of the frame using the M12 t-bolt, (1) ½" flat washer, (1) ½" lock washer and (1) M12 hex nut. Leave the nut and t-bolt loose.

Step-6 Align the hole in the mounting bracket with the hole in the frame for the tow hook, and re-install the tow hook and tow hook bolts and nut to secure the mounting bracket and tow hook, (Fig 4). Snug but do not tighten the bolts and nuts. Repeat step 4 through 6 for the passenger side mounting bracket.

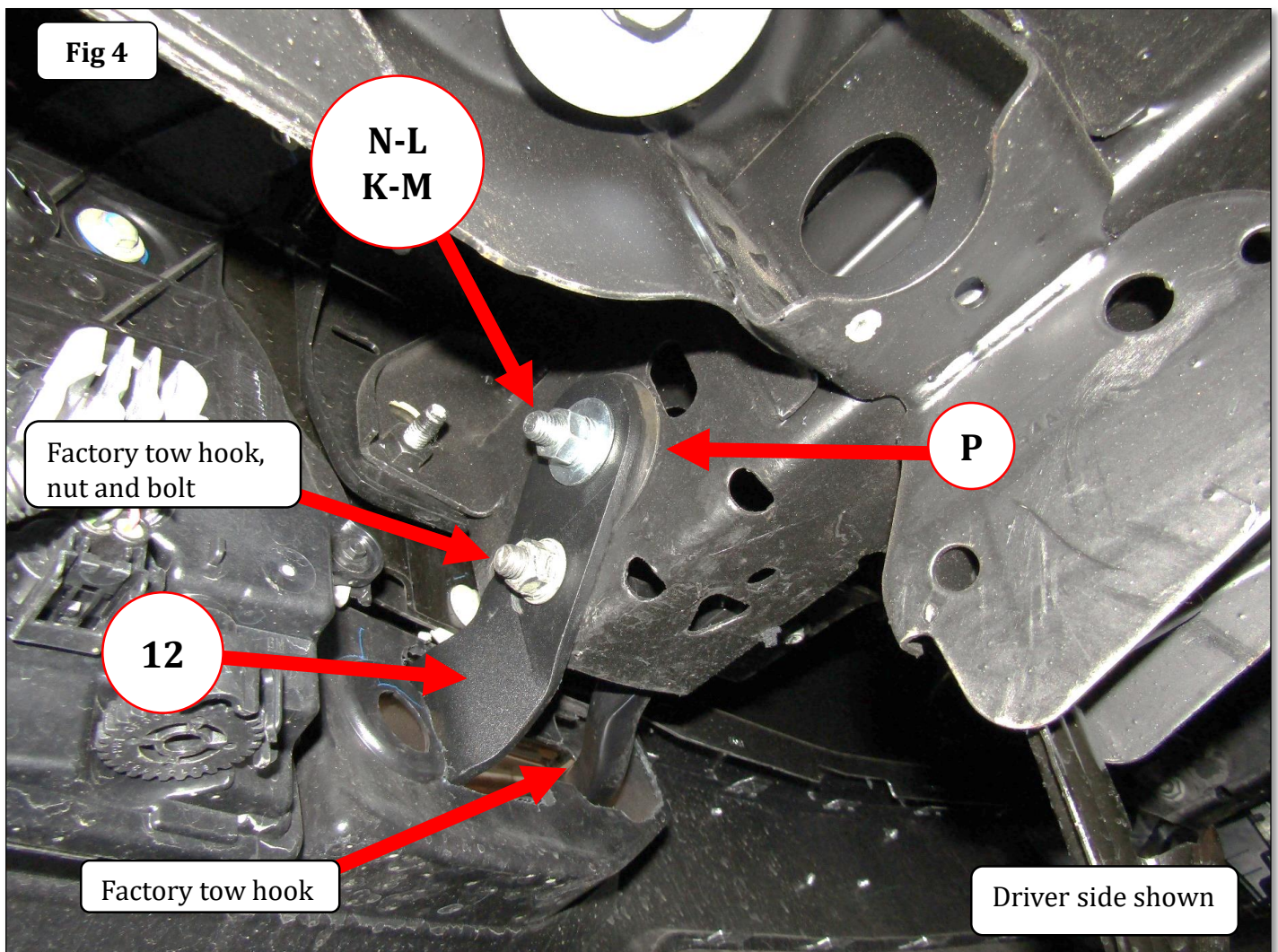

GO RHINO®

INSTALLATION INSTRUCTIONS

Vehicles without factory tow hooks:

Step-1.1 On each side of the vehicle, cut and remove the area of the bumper lower cover to clear the mounting brackets, (Fig 5). Repeat step 1.1 for the passenger side.

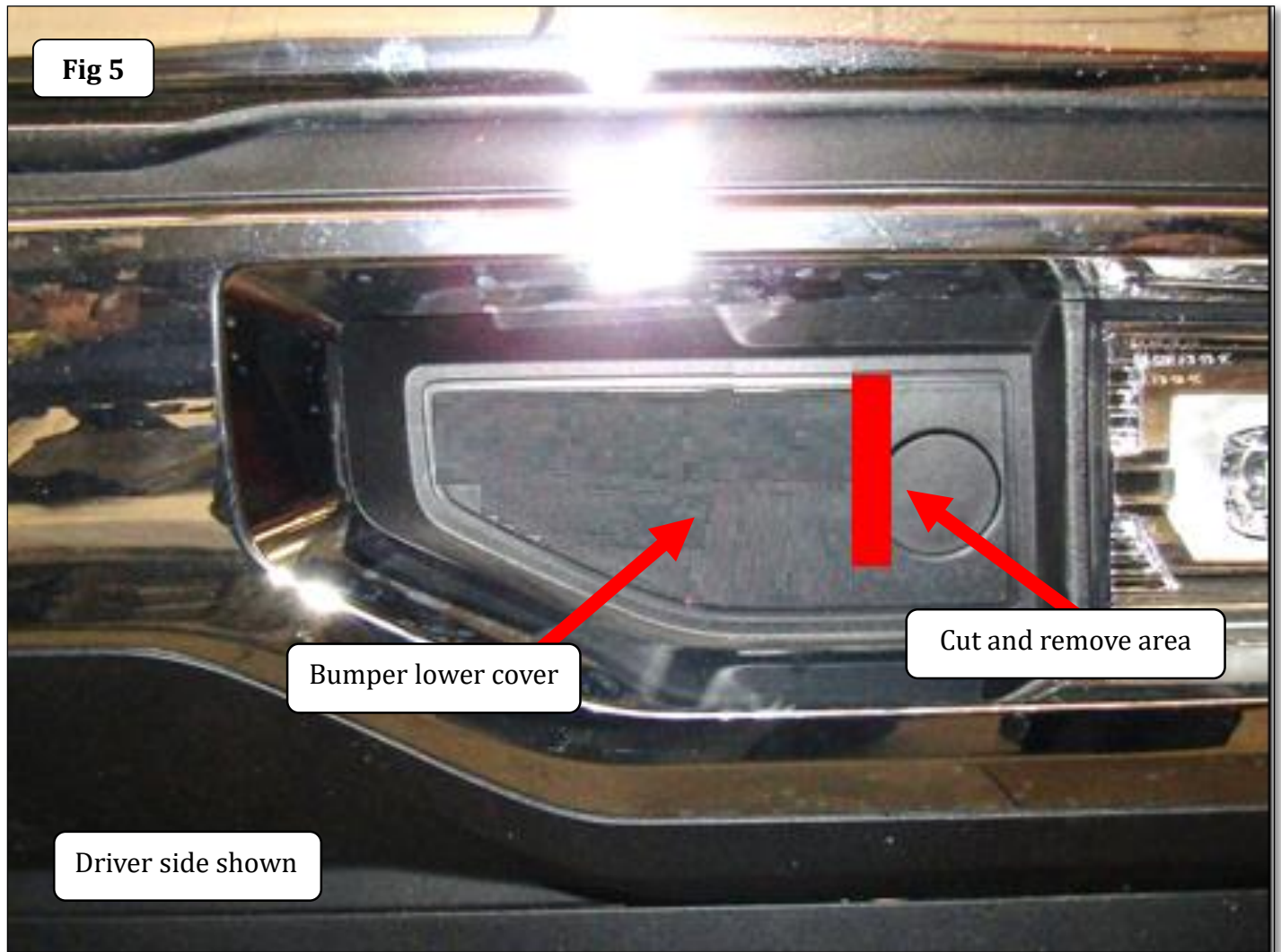

GO RHINO®

INSTALLATION INSTRUCTIONS

Vehicles without factory tow hooks:

Step-2.1 From the opening at the end of the driver side frame, position (1) M12 t-bolt inside the frame with the bolt extending out through the obround shape hole on the side of the frame. Install (1) vinyl gasket on the bolt to keep the t-bolt from falling back into the frame. Repeat to install (1) M12 t-bolt in the round hole on the side of the frame Note: To ease installation use the supplied pull wire to fish the t-bolts from the opening and out through holes in the frame.

Step-3.1 From the front of the bumper position the driver side mounting bracket through the opening in the bumper lower cover and up to the side of the frame, align the holes in the mounting bracket with the M12 t-bolts, then secure the mounting bracket to the side of the frame using the M12 t-bolts, (2) ½” flat washers, (2) ½” lock washers and (2) M12 hex nuts. Snug but do not tighten the nuts, (Fig 6). Repeat the step 2.1 and 3.1 for the passenger side mounting bracket.

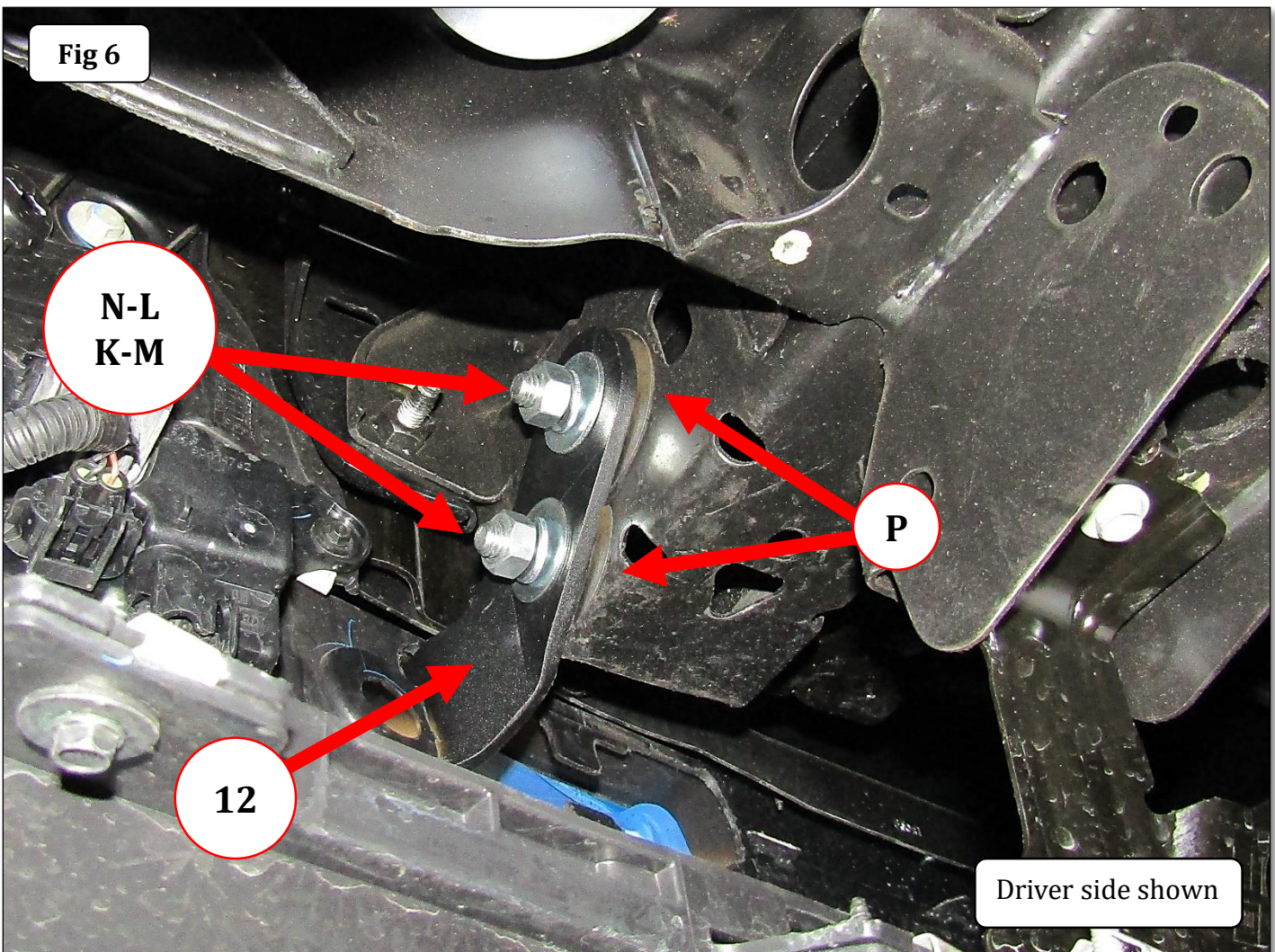

GO RHINO®

INSTALLATION INSTRUCTIONS

Step-7 Open the hood and locate the (10) plastic push pins securing the radiator cover. Using a flat blade screw driver, pry the head of the push pins up, remove push pins and lift radiator cover off. This will allow access to the bolts securing the top of the grille, (Fig 7).

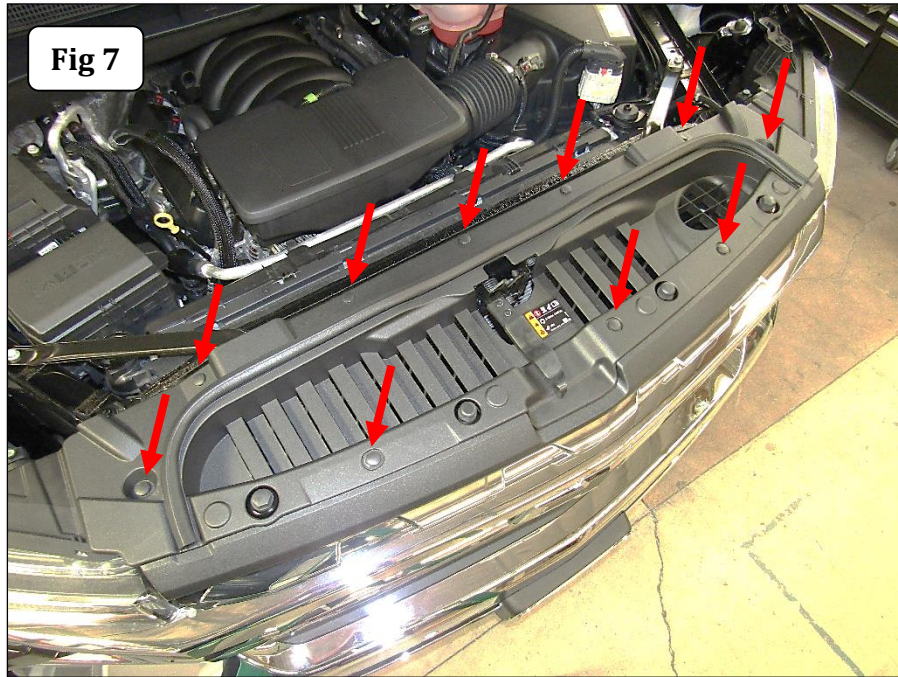

Step-8 Using a 10mm socket and ratchet, remove the (4) screws (2) per side securing the top of the grille, (Fig 8). Working from side to side, gently pull outward on the grille to unsnap the clips by the head lights, and from the sides and center of the grille. Remove the grille from the vehicle.

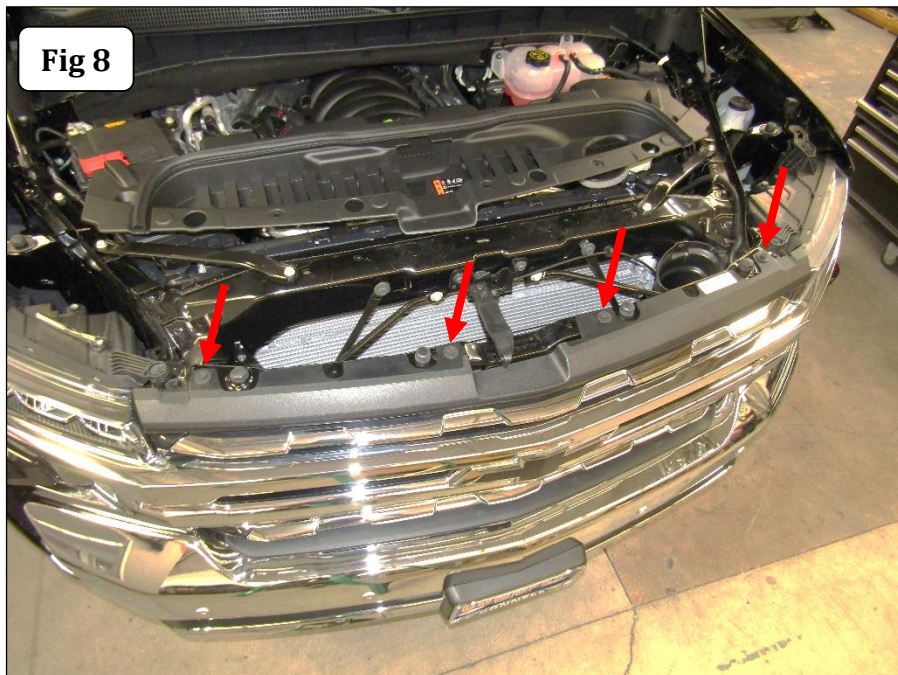

INSTALLATION INSTRUCTIONS

Step-9 On each side of the vehicle, locate the (2) hex bolts attaching the top of the bumper to the inner bumper bracket, (Fig 9). Using a 13mm socket remove the (2) hex bolts.

Step-10 Position the driver side upper bracket behind the inner bumper bracket, align the upper bracket with the holes in the inner bumper bracket and bumper then reinstall the factory hex bolts, (Fig 10). Leave the hex bolts loose. Repeat to install the passenger side upper bracket.

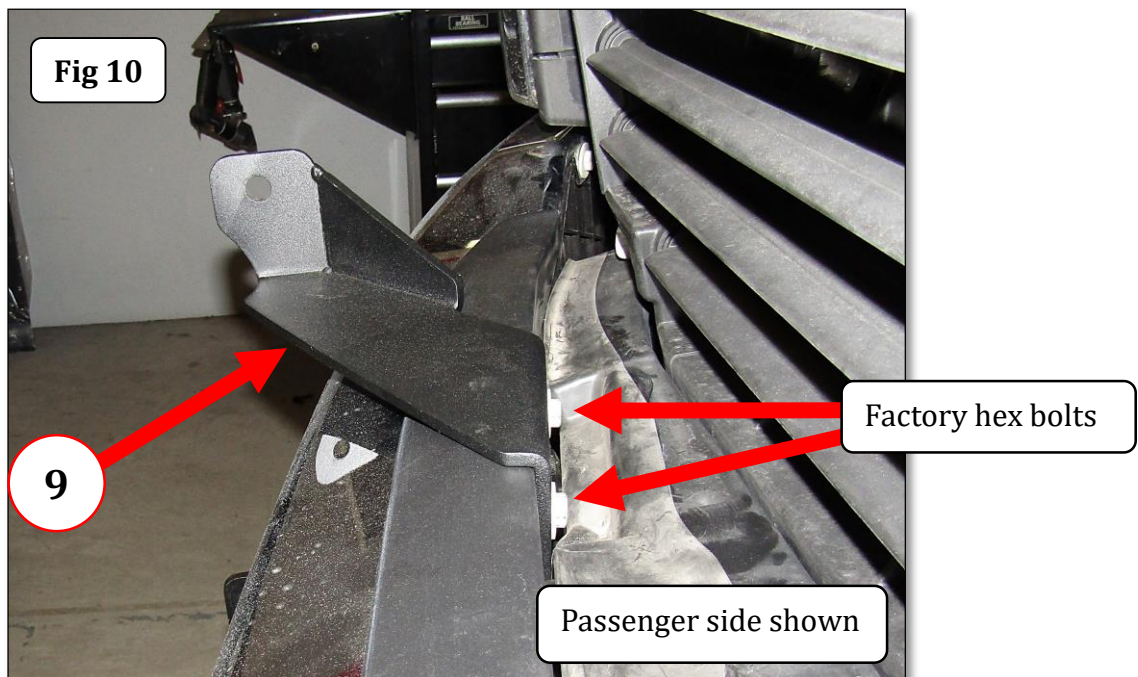
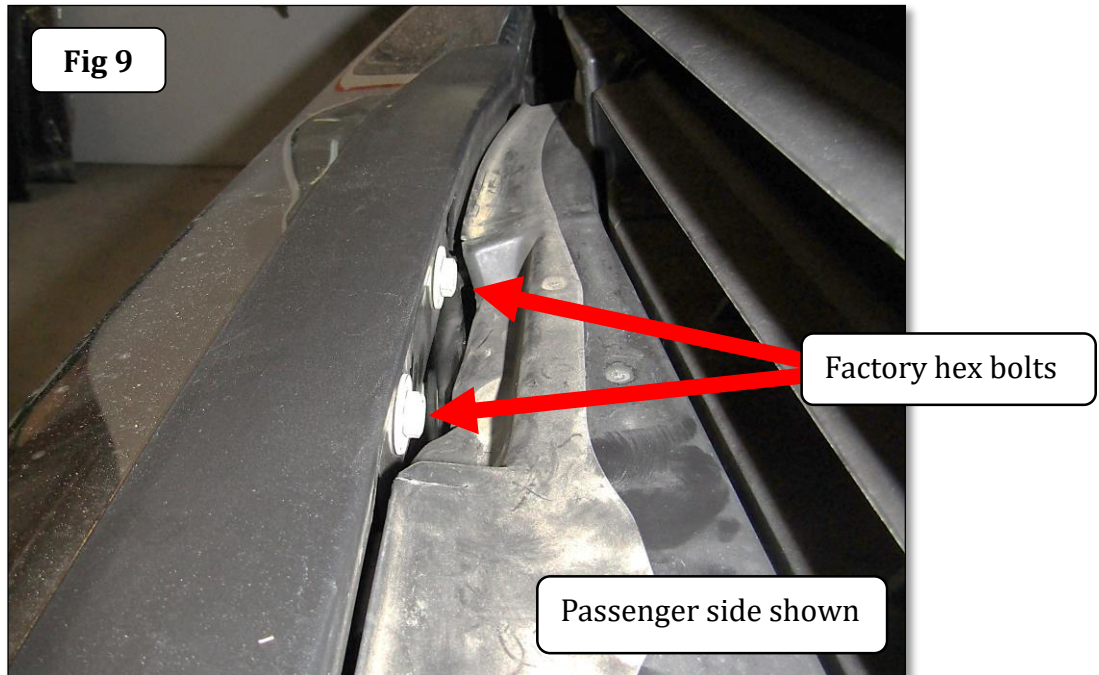

GO RHINO®

INSTALLATION INSTRUCTIONS

Step-11 Adjust the position of the upper brackets so the mounting surface of the upper brackets that attach to the grille guard are $39\frac{7}{16}$ " apart then tighten the factory hex bolts, (Fig 11).

Step-12 Reinstall the grille, radiator cover.

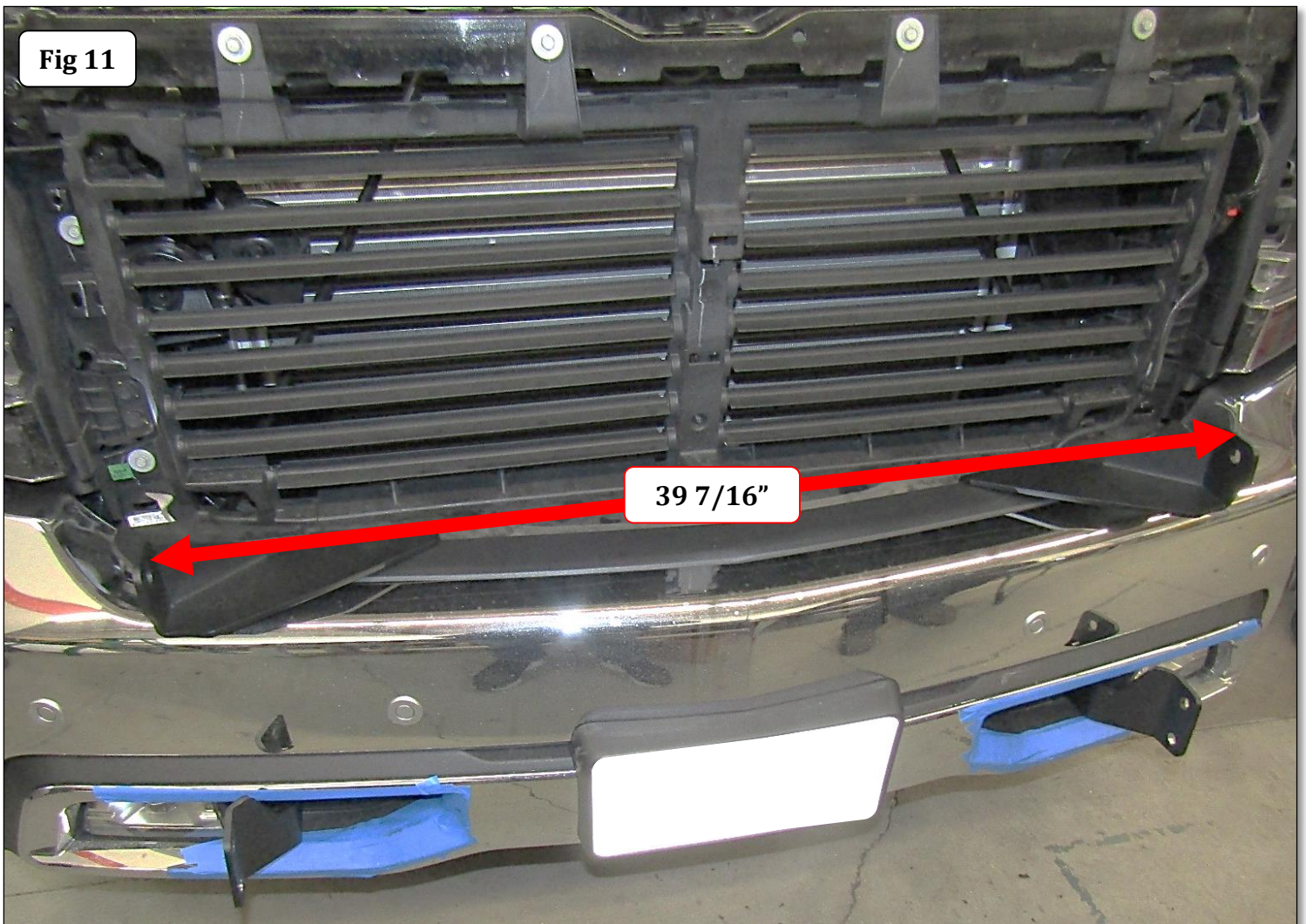

GO RHINO®

INSTALLATION INSTRUCTIONS

Step-13 With assistance, hold the grille guard up in position on the outside of the upper and lower mounting brackets.

Step-14 Align the holes in the grille guard with the holes in the upper and lower mounting brackets and attach the grille guard to the upper and lower mounting brackets using the supplied $\frac{1}{2}$ " x $1\frac{1}{2}$ " hex bolts, $\frac{1}{2}$ " flat washers, $\frac{1}{2}$ " lock washers and $\frac{1}{2}$ " hex nuts, (Fig 12).

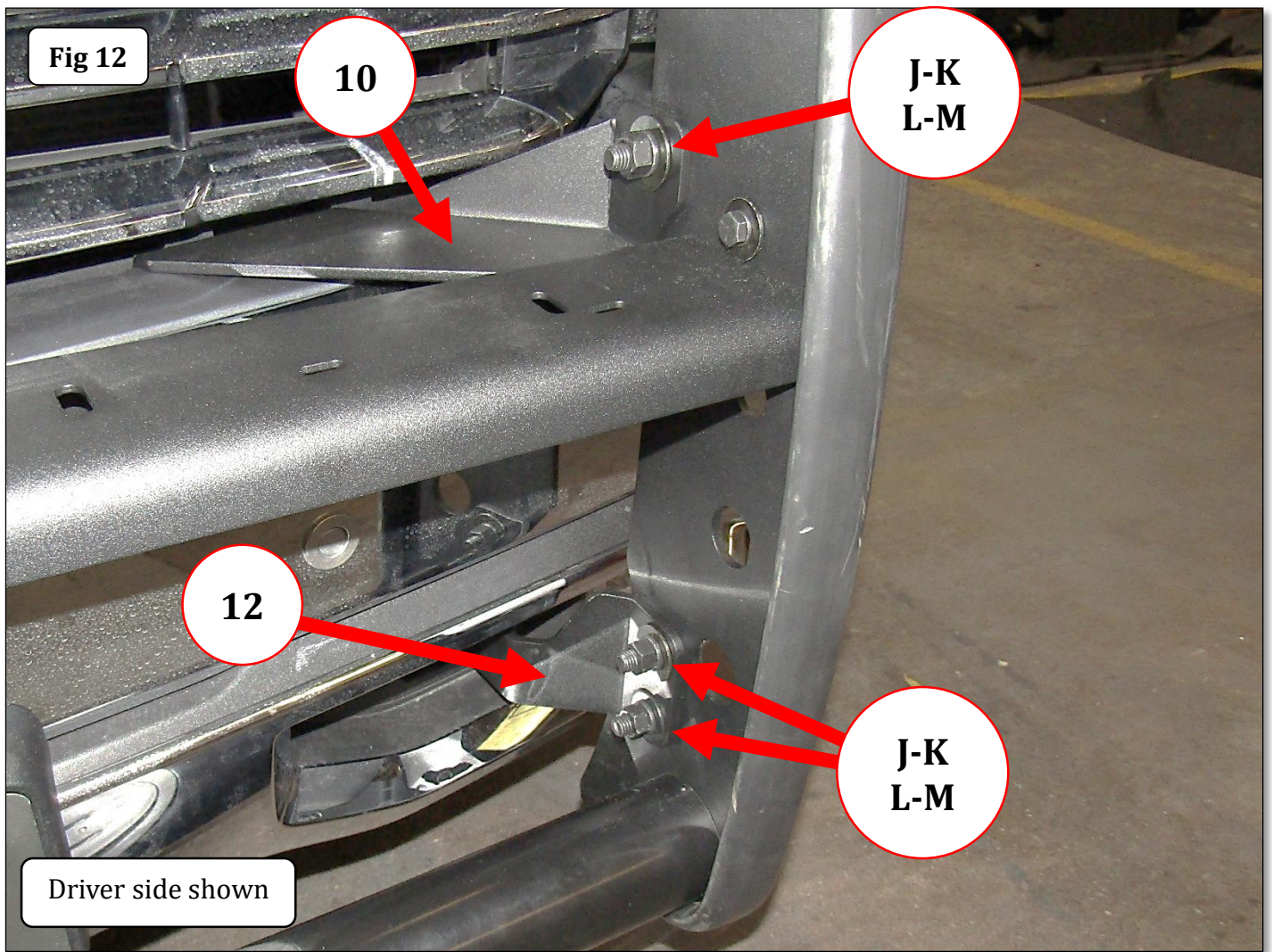

GORRHINO®

INSTALLATION INSTRUCTIONS

Step-15 Align the grille guard assembly with the vehicle and tighten all factory and or supplied nuts and bolts attaching the mounting brackets to the vehicle, and attaching the grille guard to the mounting brackets.

Fig 13



Learn more about grille guards and bull bars we have.