

# GO RHINO®

## INSTALLATION INSTRUCTIONS

### PART NO.

- 27215T

### PRODUCT DESCRIPTION:

- TRAILLINE STRAIGHT REAR BUMPER

### APPLICATION:

- JEEP WRANGLER JK

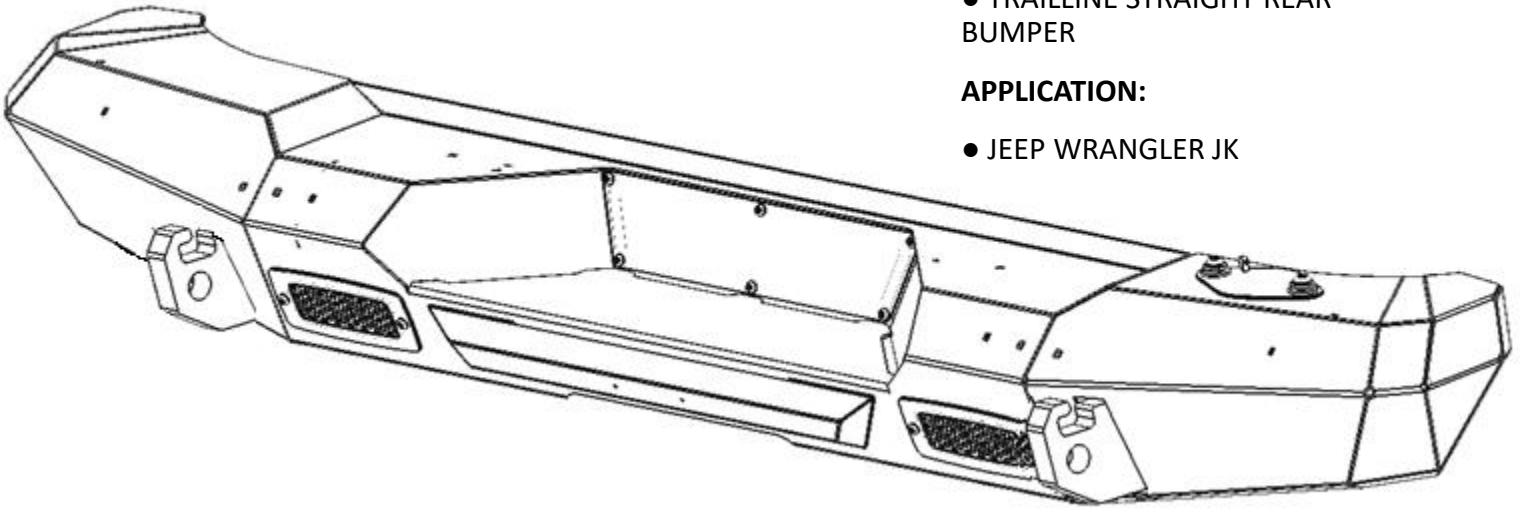

### PRODUCT SAFETY & LEGAL DISCLAIMER

- **IMPORTANT READ ALL INSTRUCTIONS CAREFULLY BEFORE INSTALLING, FAILURE TO DO SO MAY CAUSE PERSONAL INJURY OR DAMAGE TO PRODUCT AND/OR PROPERTY.**
- **Review the product package and contents prior to beginning the installation.** Take care when opening the packaging and removing items. If a return is needed you will want to return the product in its original packaging if possible.
- This instruction guide is provided as a GENERAL installation guide, some vehicles vary dimensionally and may require additional steps.
- Test fit the product on the vehicle prior to any third party modifications and or finishing. The manufacturer and/or distributors do not accept responsibility for third party charges, labor and or third part replacement modifications. Some modifications may void the factory warranty.
- Exercise due-diligence when installing this product. The manufacturer and distributors of this product do not accept any responsibility for vehicle damage or personal injury resulting from the installation of this product. Careless installation and operation can result in serious injury or equipment damage.
- This product is for general off-road use. All liability for installation and use rests with the owner/operator.
- **INSTALLER:** Once installation is complete, please return this guide along with other documentation included in this product back to the consumer for future reference. The manufacturer/distributors of this product do not guarantee this particular version will be available at a later date.



## INSTALLATION INSTRUCTIONS

### INJURY HAZARD

Please complete a shop and tool inspection prior to beginning the installation.

- Always make sure you have a clean, dry and well lit work area.
- Always remove jewelry, loose fitting clothing and wear protective gloves and eye protection.
- Always use extreme caution when jacking or raising a vehicle for work. Set the emergency brake and use tire/wheel blocks and jack stands. Refer to the vehicle manufacturer hand book. Utilize the vehicle manufacturers designated lifting points.
- Always use appropriate and adequate care in lifting parts during disassembly and installation. Seek help in lifting heavy or large items into place. Utilize jacks and or lifting devices when available.
- Always insure products are secure during disassembly and installation.
- Always wear eye protection and take steps to protect any exposed skin during the installations. Drilling, cutting and grinding plastic and metal may create flying particles that can cause injury.
- Always use extreme caution when drilling, cutting and or grinding on a vehicle. Thoroughly inspect the area to be drilled, on both sides of material, prior to modification and relocate any objects that may become damaged.
- Always assemble and tighten all fasteners per the installation instructions.
- Always route electrical cables carefully. Avoid moving parts, parts that may become hot and rough or sharp edges.
- Always insulate and protect all exposed wiring and electrical connections.

### MAINTENANCE AND CARE

- Always perform regular inspections and maintenance on mounts and related fasteners.
- Periodically check and tighten all fasteners.
- Stripped, fractured, or bent fasteners must be replaced.
- After washing the vehicle make sure to fully dry all surfaces.
- In areas with cold temperatures make sure to wash the product often to remove harmful materials used on road ways.
- Never use abrasive cleaners or polish compounds. Clean with a gentle soap and water. If you use wax use a non-abrasive automotive wax such as pure carnauba wax.

### WARNING

Some products have been designed to work together with factory rear sensor systems, factory forward facing sensor systems and factory air bags.

- Installation of some of these products may alter the factory sensor system performance.
- Factory sensors may read shackles or hooks protruding from the fairlead and or tow hooks.
- All sensor testing is completed by Go Rhino Products and or third party testing labs on modified vehicles.
- Sensor sensitivity, factory sensor housing, orientation, and operating conditions are all variables that will influence functionality of the sensors.
- Installation of some product may effect the factory air bag systems.
- Some products allow the use of third party products such as winches, shackles, hooks, etc. Follow the respective manufacturers operating instructions for use with our products.
- Make sure to fully understand the product, it's intended use and operation prior to use.
- Above all... be safe!

# GO RHINO®

## INSTALLATION INSTRUCTIONS

### PARTS INCLUDED IN THIS LIST:

ITEM	QTY.	DESCRIPTION	ITEM	QTY.	DESCRIPTION
A	6	3/8" x 1 1/4" Hex Head Bolt	F	4	M10 Flat Washer
B	6	3/8" Lock Washer	G	8	1/2" x 1 1/4" Hex Head Bolt
C	6	3/8" Flat Washer	H	8	1/2" Lock Washer
D	4	M10 x 35mm Hex Head Bolt	I	8	1/2" Flat Washer
E	4	M10 Lock Washer			

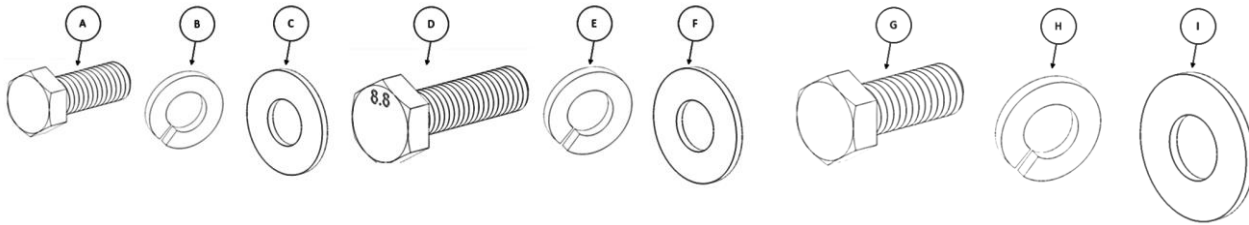

US Recommended Bolt Torque  
Bolt Diameter

Recommended Torque  
Grade 5      Grade 8      18-8 S/S

Bolt Diameter	Grade 5	Grade 8	18-8 S/S
1/4"	6.3	9	6.3
5/16"	13	18	11
3/8"	23	33	20
7/16"	37	52	31
1/2"	57	80	43
9/16"	82	115	57

Sizes from 1/4" up are in lb-ft.

Grade 5 and 8 values are for slightly lubricated bolts.

Metric Recommended Bolt Torque  
Bolt Diameter

Recommended Torque  
Class 8.8      Class 10.9

Bolt Diameter	Class 8.8	Class 10.9
5	7	9
6	12	16
8	30	40
10	55	75
12	100	135
14	160	215

Go Rhino recommends you, the installer, read this installation instruction manual from front to back before installing the product.

### TOOLS NEEDED FOR INSTALLATION:

- Inch & Metric Sockets
- Inch & Metric Wrenches
- Ratchet, Ratchet Extensions & Swivel Joint Adapter

ESTIMATED TIME FOR INSTALLATION:

2 Hour

# GORRHINO®

## INSTALLATION INSTRUCTIONS

PARTS INCLUDED IN THIS LIST:

ITEM	QTY.	DESCRIPTION	ITEM	QTY.	DESCRIPTION
J	1	Corner Bracket (Driver)	O	1	Frame Bracket (Passenger)
K	1	Frame Bracket (Driver)	P	1	Corner Bracket (Passenger)
L	1	Interior Frame Bracket (Driver)	Q	1	Trailline Rear Bumper
M	2	Center Bracket	R	2	Mesh vent Covers (Pre-Installed)
N	1	Interior Frame Bracket (Passenger)			

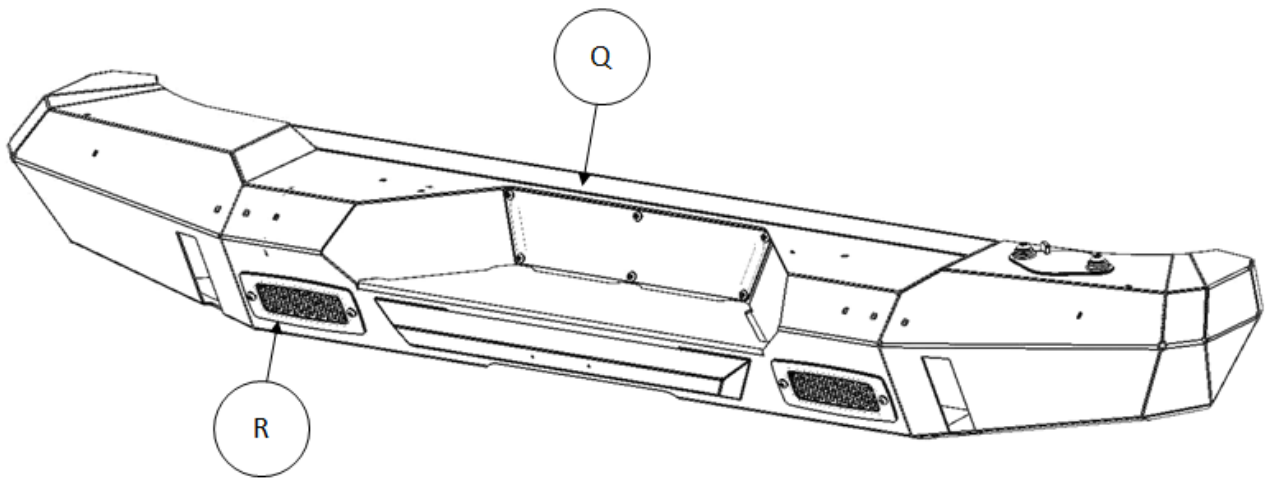
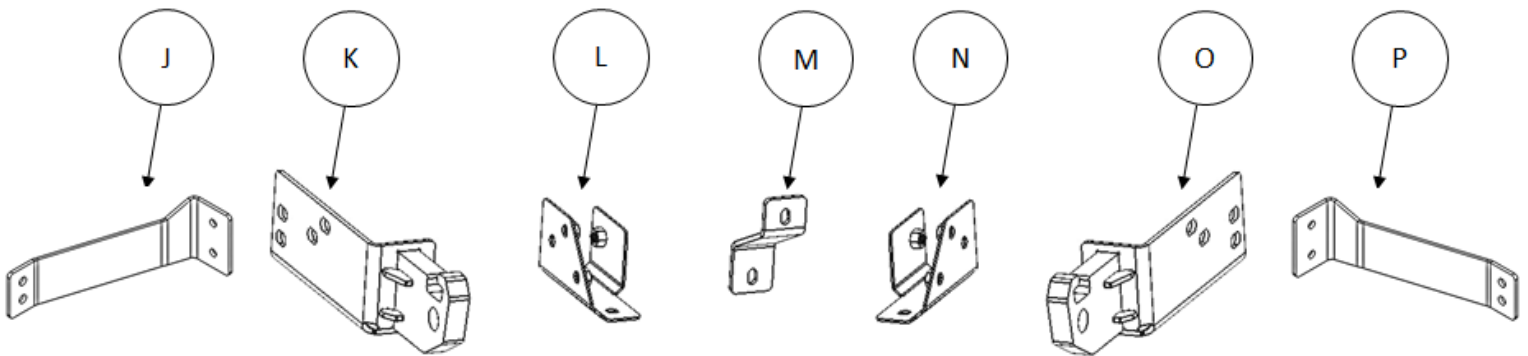

# GO RHINO®

## INSTALLATION INSTRUCTIONS

### OEM Rear Bumper Removal

**Step-1** Remove the spare tire from the spare tire mount, (FIGURE 1).



**Step-2** Beginning on the driver side, remove the (2) bolts securing the OEM bumper corner bracket to the side of the frame using an 16mm socket, (FIGURE 2). Repeat this step for the passenger side.

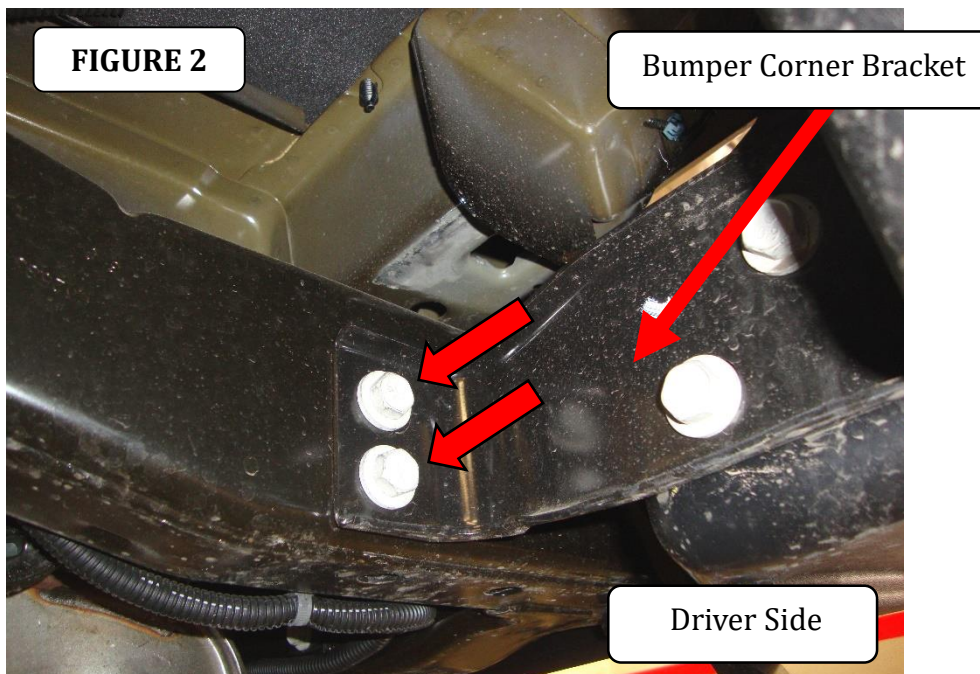

# GO RHINO®

## INSTALLATION INSTRUCTIONS

**Step-3** From behind the OEM bumper remove the (2) bolts securing the bumper center bracket to the back of the bumper and to the receiver hitch cross bar using an 16mm socket, (FIGURE 3). Repeat this step for the passenger side.

**Step-4** With assistance remove the OEM bumper from the vehicle and set aside.

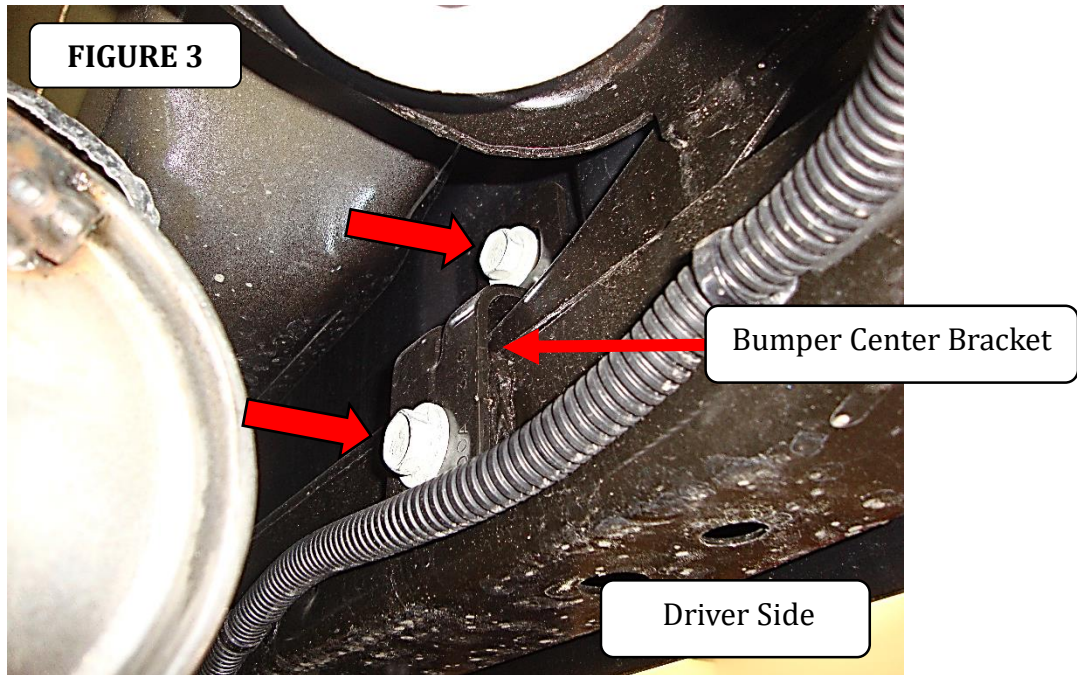

**Step-5** Remove the (3) bolts securing the OEM tow hook to the frame using an 18mm socket, (FIGURE 4). The tow hook will not be reinstalled.

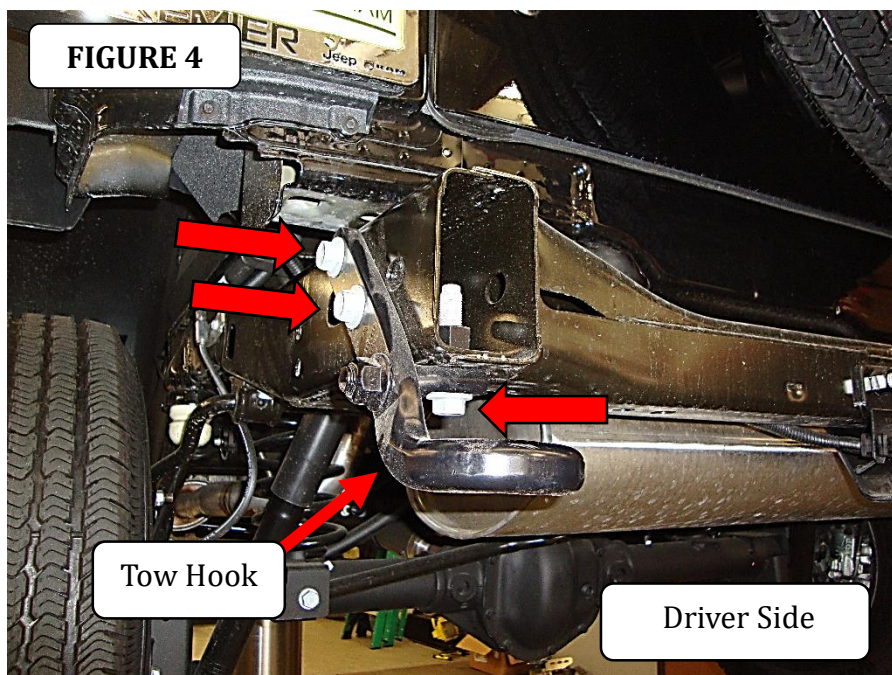

# GO RHINO®

## INSTALLATION INSTRUCTIONS

### Trailline Bumper Installation

**Step-1** From the opening in the end of the frame, position the driver side interior frame bracket inside the frame. Align the bracket weld nut with the hole in the side of the frame toward the center of the vehicle and secure the bracket to the frame using (1) ½" 1 ¼" hex head bolt, (1) ½" lock washer and (1) ½" flat washer, (FIGURE 1 & 2). Leave the bolt loose for final adjustment. Repeat this step for the passenger side.

FIGURE 1

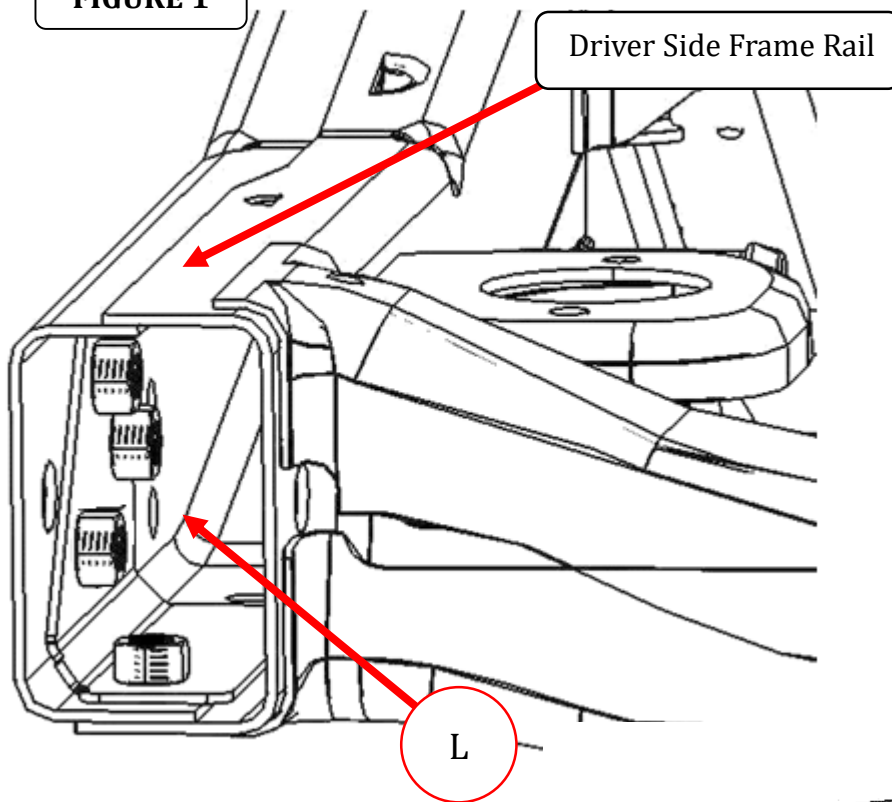
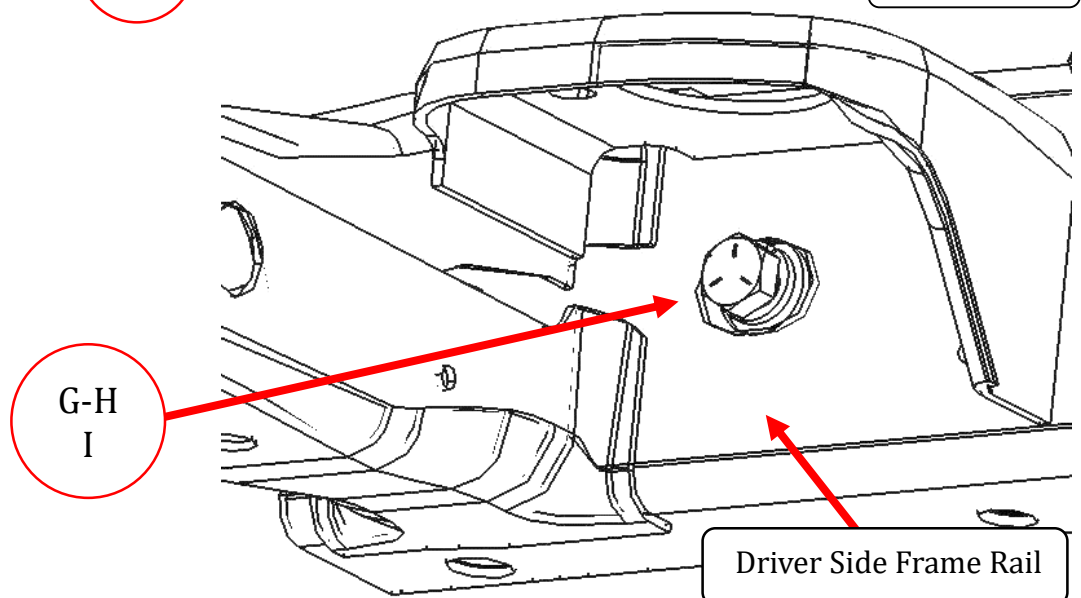

FIGURE 2



# GORRHINO®

## INSTALLATION INSTRUCTIONS

**Step-2** Position the driver side frame bracket up to the bottom and side of the frame. Align the holes in the frame bracket with the interior bracket weld nuts and secure the frame bracket to the frame using (3) ½" x 1 ¼" hex head bolts, (3) ½" lock washers and (3) ½" flat washers, (FIGURE 3 & 4). Leave the bolts loose for final adjustment. Repeat this step for the passenger side.

FIGURE 3

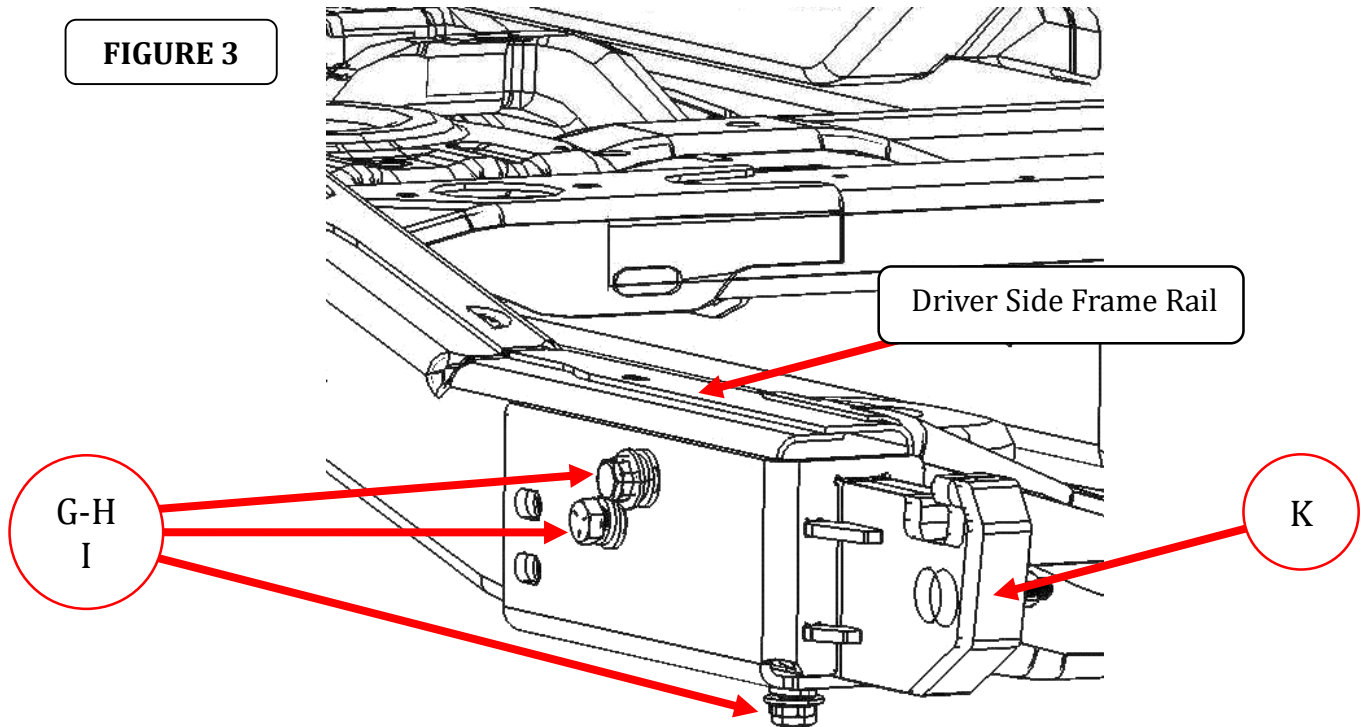

**Step-3** With assistance lift the bumper up to the vehicle, and position the bumper so the driver and passenger side frame bracket D-Shackle mounts protrude out through the rectangular openings in the bumper, (Photo 5).

FIGURE 4

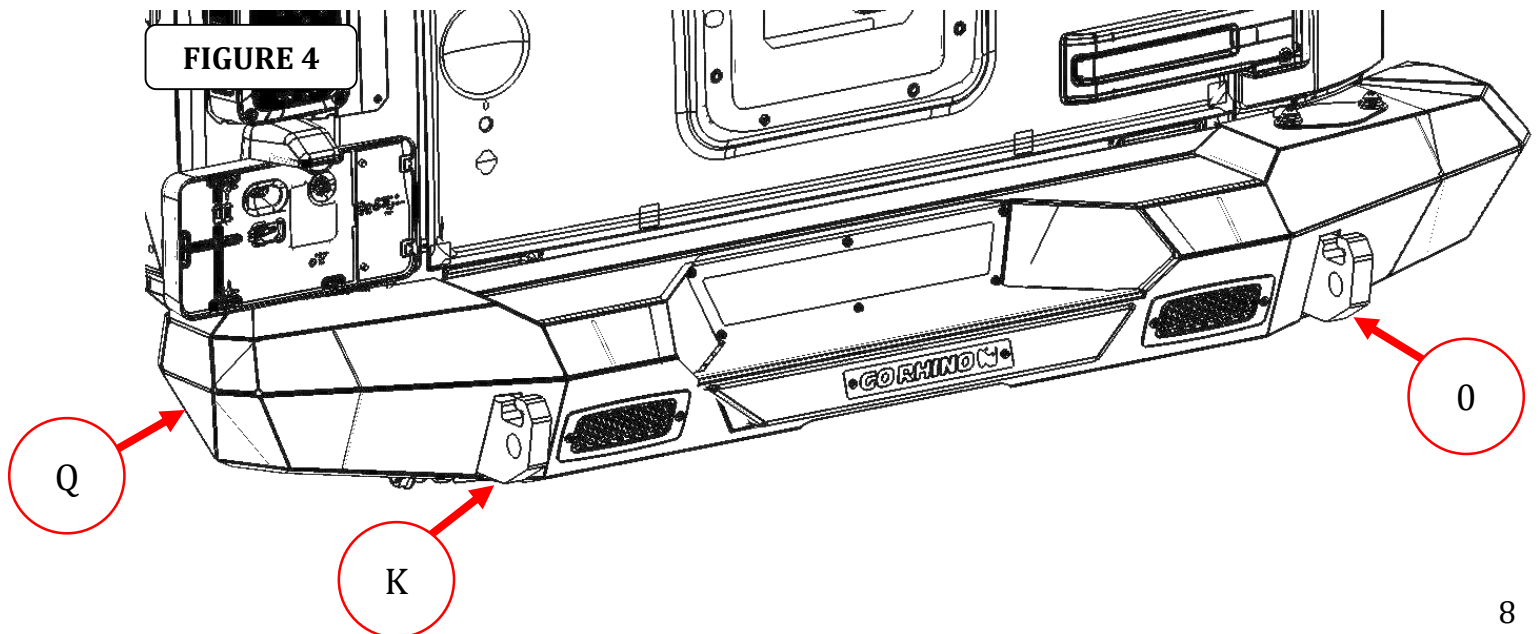



# GORRHINO<sup>®</sup>

## INSTALLATION INSTRUCTIONS

**Step-4** Position the driver side corner bracket up to the side of the frame bracket. Align the holes in the corner bracket with the holes in the frame bracket and the weld nuts inside the frame and secure the corner bracket to the frame using (2) ½" x 1 ¼" hex head bolts, (2) ½" lock washers and (2) ½" flat washers, (FIGURE 5). Leave the bolts loose for final adjustment.

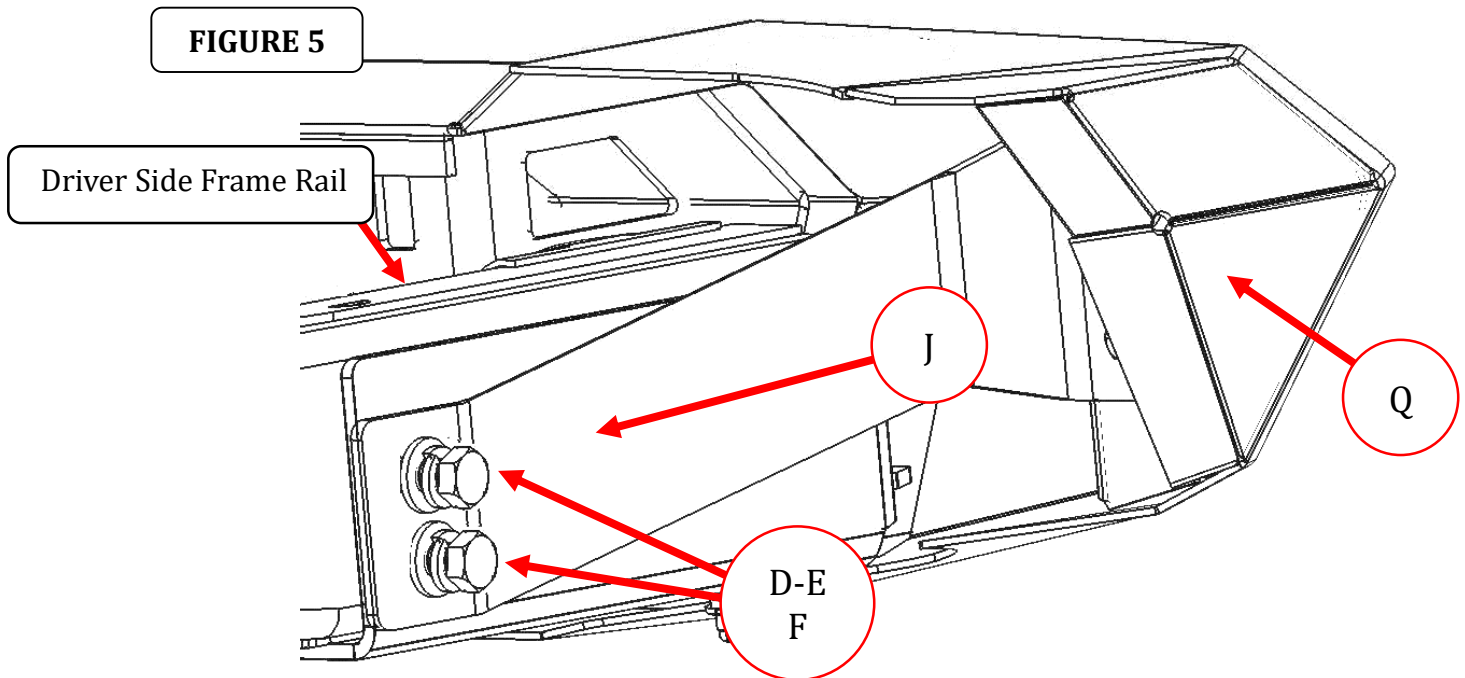

**Step-5** Align the holes in the corner bracket with the weld nuts in the Trailline bumper and secure the corner bracket to the bumper using (2) ½" x 1 ¼" hex head bolts, (2) ½" lock washers and (2) ½" flat washers, (FIGURE 6). Leave the bolts loose for final adjustment. Repeat step 4 and 5 for the passenger side.

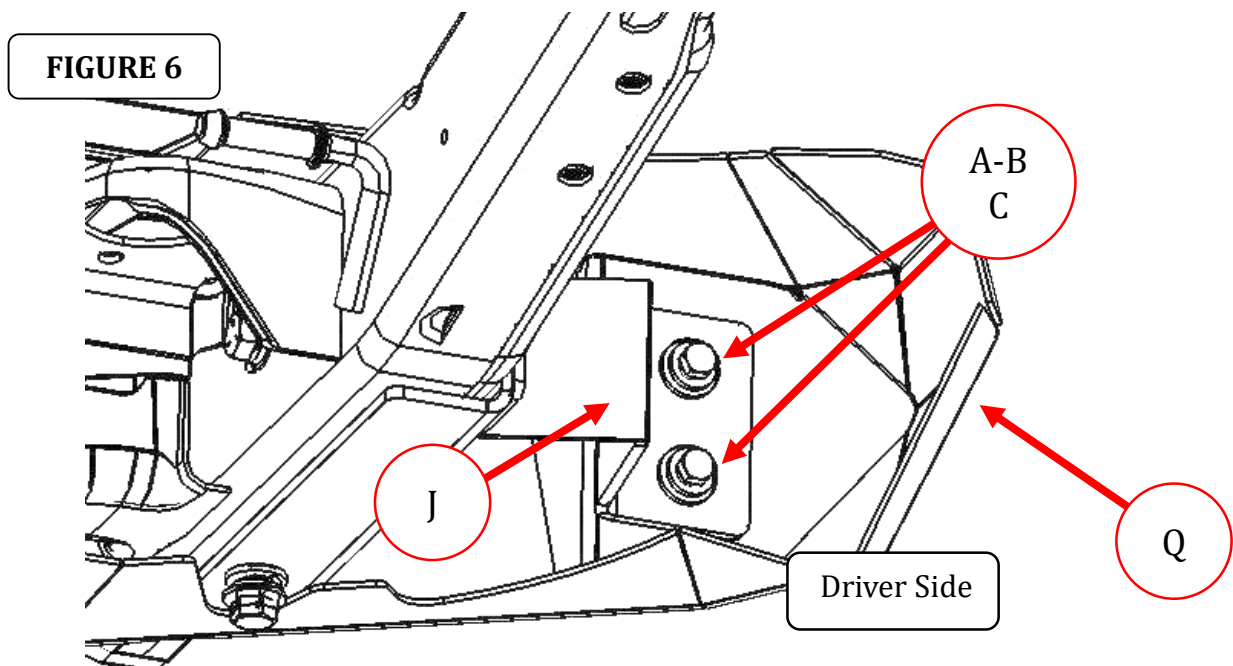

# GO RHINO®

## INSTALLATION INSTRUCTIONS

**Step-7** From under the Trailline bumper, position one of the center brackets lower leg over the receiver hitch cross bar, and attach the bracket to the receiver hitch cross bar using (1) M10 x 35mm hex head bolt, (1) M10 lock washer and (1) M10 flat washer. Attach the opposite end of the center bracket to the Trailline bumper bracket weld nut using (1) 3/8" x 1 1/4" hex head bolt, (1) 3/8" lock washer and (1) 3/8" flat washer and (FIGURE 7). Leave the bolts loose for final adjustment. Repeat to install the remaining center bracket.

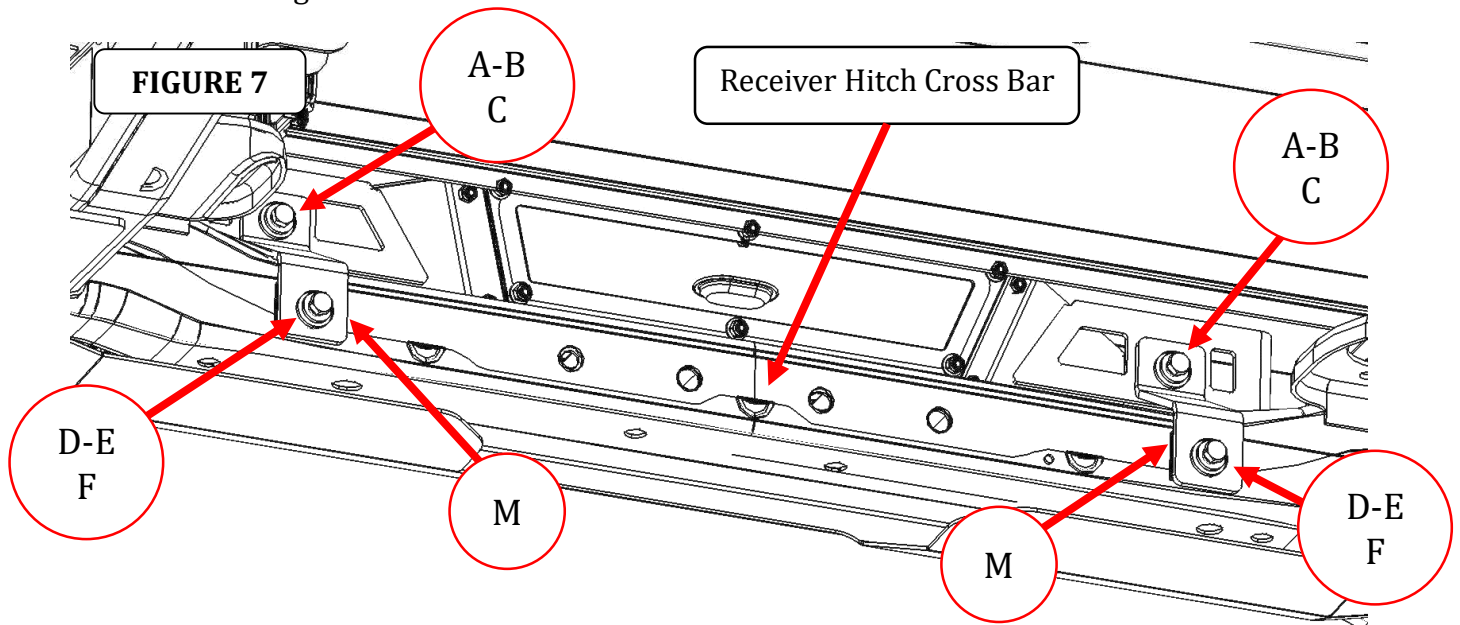

**Step-8** With assistance, adjust and hold the Trailline bumper visual alignment position, then tighten all bolts securing the brackets and Trailline bumper.

