



# INSTRUCTION MANUAL

## CAT-BACK DUAL SPORT EXHAUST

FORD F150 TRUCK, 4.9L, 5.0L  
 FORD F250/F350 TRUCK 5.8L  
 STANDARD CAB, LONG BED  
**PART # 9800**

CATALYTIC CONVERTER

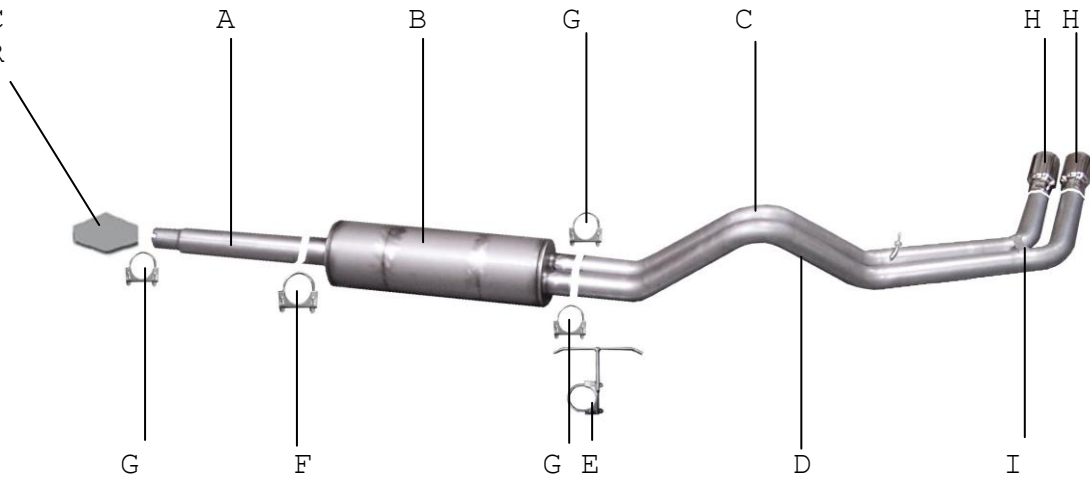

ITEM	PART #	QTY.	DESCRIPTION
A	700279	1	3" X 19 1/2" HEADPIPE
B	789800	1	SUPERFLOW DUAL OUTLET MUFFLER
C	700256	1	2-1/2" PASSENGER SIDE OVERAXLE PIPE
D	700255	1	2-1/2" DRIVER SIDE OVERAXLE PIPE
E	4141	1	O.E. REAR MUFFLER HANGER
F	ODH300	1	3" CLAMP
G	5757	3	2-1/2" CLAMP
H	500396	2	3-1/2" STAINLESS TIPS
I	BO-906	1	BOLT KIT FOR TAILPIPE

# INSTALLATION INSTRUCTIONS

WHEN INSTALLING THIS EXHAUST SYSTEM MAKE SURE TO USE ALL THE PROPER SAFETY PRECAUTIONS. USE JACK STANDS WHEN UNDER TRUCK, SET PARKING BRAKE, BLOCK TIRES AND USE SAFETY GLASSES.

**DO NOT WORK WITH HOT PIPES!**

## SUGGESTED TOOLS:

15MM SOCKET, 9/16" SOCKET, 1/2" SOCKET, 1/2" WRENCH, JACKSTAND, HACKSAW

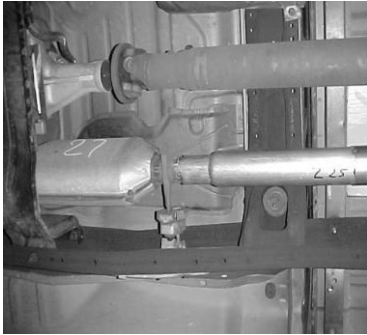

LAYOUT THE GIBSON EXHAUST SYSTEM ON THE FLOOR SO IT LOOKS LIKE THE DRAWING. THEN REMOVE THE STOCK EXHAUST SYSTEM, BUT LEAVE ALL RUBBER GROMMETS IN PLACE. START WITH INSTALLING HEADPIPE #A ONTO CATALYTIC CONVERTER AND CLAMP #G. **DO NOT TIGHTEN!**

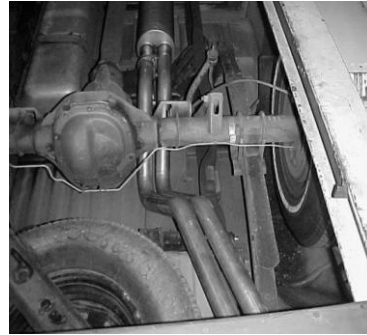

THEN USE SUPPLIED HARDWARE BOLT KIT #I TO BOLT TOGETHER THE OVERAXLE TAILPIPES. **DO NOT TIGHTEN!** THE TAB ON THE DRIVER SIDE TAILPIPE WILL BE ON TOP OF THE PASSENGER SIDE TAILPIPE.

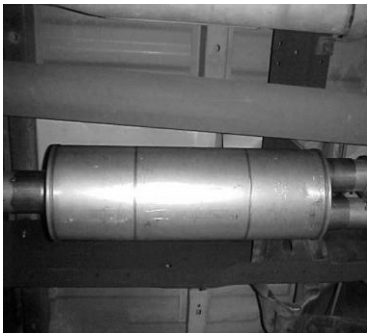

THEN INSTALL MUFFLER #B ONTO HEADPIPE #A AND CLAMP USING #F BUT DO NOT TIGHTEN. TO HELP SUPPORT YOUR MUFFLER, USE A JACK STAND. BEFORE INSTALLING OVERAXLE TAILPIPE, INSTALL REAR MUFFLER HANGER #E.



WHEN EVERYTHING IS IN PLACE, FIRMLY TIGHTEN ALL BOLTS AND CLAMPS.



THEN, INSTALL DRIVERSIDE TAILPIPE #D. SUPPORT THE MUFFLER WITH A JACK STAND. THEN INSTALL PASSENGER SIDE OVERAXLE #C. INSERT WELDED HANGER ON TAILPIPE INTO FACTORY RUBBER GROMMET. **NOTE: SPARE TIRE MAY HAVE TO BE LOOSENED AND MOVED FOR BETTER CLEARANCES.**



INSTALL STAINLESS TIPS. TO CLEAN TIPS, USE ANY ALUMINUM OR STAINLESS POLISH.

**MAKE SURE YOU HAVE AT LEAST 1" CLEARANCE ON ALL PIPES, RUBBER HOSES, TIRES, BRAKE LINES, ETC.**