



INSTRUCTION MANUAL

CAT-BACK DUAL SPORT STAINLESS EXHAUST

NISSAN TITAN 5.6L V8

CREW CAB, LONG BED

PART# 68400

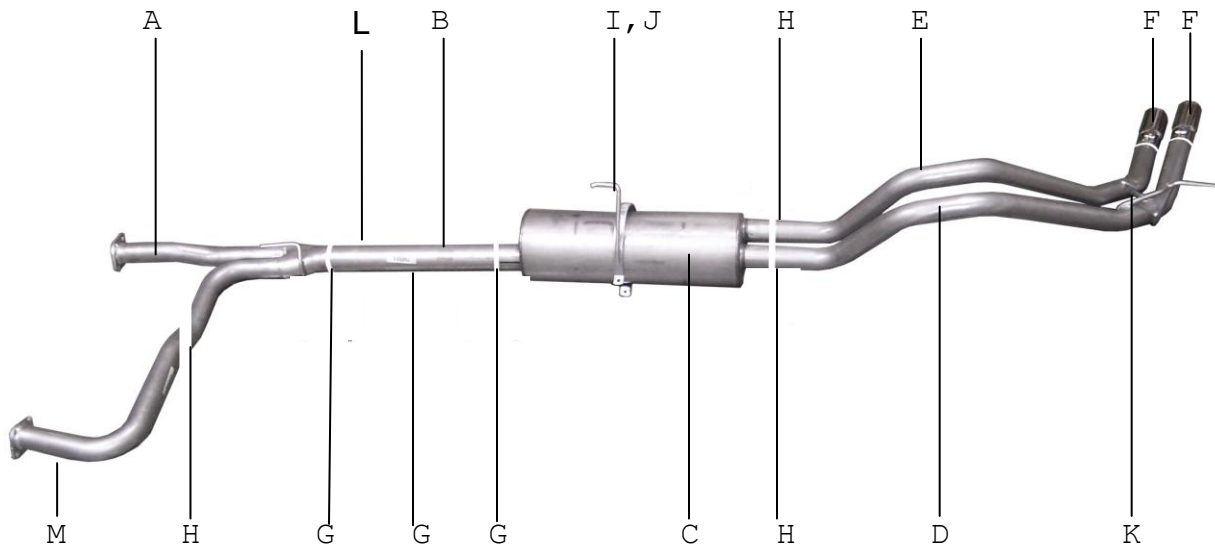

ITEM	PART #	QUANTITY	DESCRIPTION
A	794-700550S	1	2 ½" SS Y-PIPE W/GP-110 FLANGES
B	795-700551S	1	3" SS RESONATOR
C	758250S	1	SS SUPERFLOW MUFFLER
D	797-700552S	1	2-1/2" SS DRIVERS SIDE TAILPIPE
E	798-700553S	1	2-1/2" SS PASS. SIDE TAILPIPE
F	500374	2	3-1/2" STAINLESS TIPS
G	OHD300	3	3"CLAMPS
H	5757	3	2-1/2" CLAMPS
I	4322	1	BAND CLAMP
J	BO-1015	1	BOLT KIT FOR BAND CLAMP
K	BO-906	1	BOLT KIT FOR TAILPIPES
L	1335-701091S	1	3" SS EXTENSION PIPE
M	1336-700550S-1	1	SS HEAD PIPE WITH GP110 FLANGE

EXHAUST INSTALLATION #68400

When installing this exhaust system make sure to use proper safety precautions. Use jack stands when under the truck, set parking brake, block tires and use safety glasses and gloves.

DO NOT WORK WITH HOT PIPES!

SUGGESTED TOOLS:

1/2", 9/16", 12MM/14MM/15MM Socket, WD-40, Jack Stand, Hacksaw or Sawzall



LAY OUT THE GIBSON EXHAUST ON THE FLOOR AND COMPARE PART #'S TO THE DRAWING. TO REMOVE YOUR FACTORY EXHAUST UN-BOLT YOUR TAILPIPE AT THE 2-BOLT FLANGE LOCATED BEHIND YOUR STOCK MUFFLER USE WD-40 TO AID YOU IN REMOVAL OF HANGERS FROM RUBBER GROMMETS.



INSTALL BAND CLAMP # I ONTO MUFFLER, INSERT HANGER INTO RUBBER GROMMET, USE BOLT KIT PROVIDED, DO NOT TIGHTEN.

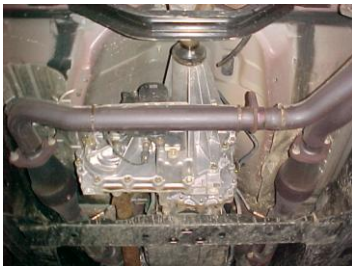

NEXT, UN-BOLT YOUR EXHAUST FROM THE 2-BOLT FLANGES LOCATED JUST BEHIND YOUR FACTORY CATALYTIC CONVERTERS, DO NOT DISGUARD YOUR FACTORY GASKETS AND HARDWARE YOU WILL RE-USE IT.



INSTALL PASS. SIDE TAILPIPE # E INTO MUFFLER 1 1/2"-2". USE CLAMP # H TO SECURE PIPE TO MUFFLER, DO NOT TIGHTEN.



INSTALL Y-PIPE # A & M ONTO STOCK FLANGES USE YOUR STOCK HARDWARE TO SECURE INSERT WELDED HANGER INTO RUBBER GROMMET, DO NOT TIGHTEN.



NEXT, INSTALL DRIVERS SIDE TAILPIPE # D INTO MUFFLER 1 1/2"-2". INSERT WELDED HANGER INTO RUBBER GROMMET, BOLT TAILPIPES TOGETHER WITH BOLT KIT # K. DRIVERS SIDE TAB WILL BE ON THE BOTTOM.



INSTALL EXTENSION PIPE #L ONTO HEADPIPE. INSERT WELDED HANGER INTO GROMMET. USE CLAMP # G TO SECURE. DO NOT TIGHTEN.

NEXT, INSTALL RESONATOR # B 1 1/2"-2" ONTO Y-PIPE USE CLAMP # G TO SECURE PIPES TOGETHER, DO NOT TIGHTEN.

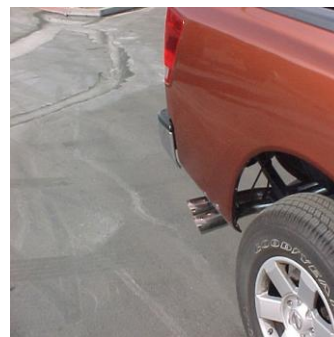

INSTALL YOUR STAINLESS TIP TO YOUR DESIRED LOOK. NOW GO BACK AND TIGHTEN ALL YOUR FLANGES, CLAMPS, ETC. STARTING FROM THE FRONT AND WORKING YOUR WAY BACK. TO CLEAN YOUR STAINLESS TIP USE A STAINLESS CLEANER AND A SCOTCH BRITE PAD.



INSTALL MUFFLER # C ONTO YOUR RESONATOR 1 1/2"-2". USE CLAMP # G TO SECURE MUFFLER TO THE PIPE, DO NOT TIGHTEN.

MAKE SURE YOU HAVE A 1" CLEARANCE ON ALL RUBBER BRAKE LINES, SHOCK BOOTS, TIRES, FUEL LINES, ETC...