



PERFORMANCE EXHAUST SYSTEMS

INSTRUCTION MANUAL

CAT-BACK STAINLESS EXTREME DUAL EXHAUST

DODGE DAKOTA TRUCK 3.9L- 5.2L-5.9L 2/4WD

DODGE DAKOTA TRUCK 5.9L RT 2WD

EXTENDED CAB, SHORT BED

PART # 66536

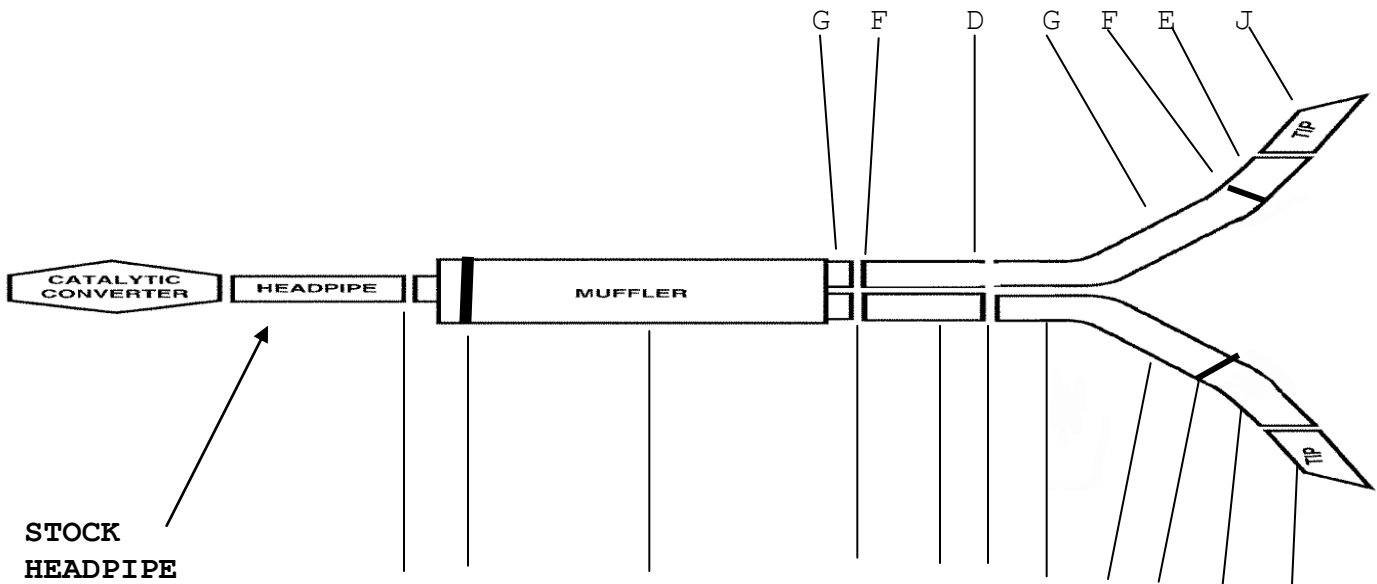

STOCK
HEADPIPE
DO NOT
REMOVE

F I,L A F B F C H F E J

ITEM	PART #	QTY	DESCRIPTION
A	789800S-3	1	STAINLESS SUPERFLOW DUAL OUTLET MUFFLER
B	263-700005S-A	1	2-1/2" SS FRONT DRIVERSIDE TAILPIPE
C	264-700005S-B	1	2-1/2" SS DRIVERSIDE OVERAXLE PIPE
D	265-700010S	1	2-1/2" SS PASSENGERSIDE OVERAXLE TAILPIPE
E	552-700413S	2	2.5" SS EXIT PIPE
F	5757	8	2-1/2" CLAMP
G	800005	1	O.E. HANGER
H	800006	2	O.E. STRAP HANGER
I	4150	1	BAND CLAMP
J	500374	2	3-1/2" STAINLESS TIPS
L	BO-1015	1	BAND CLAMP BOLT KIT
K	ZIP	2	ZIP TIES

EXHAUST INSTALLATION KIT# 66536

WHEN INSTALLING THIS EXHAUST SYSTEM MAKE SURE TO USE ALL THE PROPER SAFETY PRECAUTIONS. USE JACK STANDS WHEN UNDER TRUCK, SET PARKING BRAKE, BLOCK TIRES AND USE SAFETY GLASSES AND GLOVES. **DO NOT WORK WITH HOT PIPES!**

SUGGESTED TOOLS:

15mm Wrench, 9/16 Socket, 1/2 Wrench, Jack Stand, Hacksaw

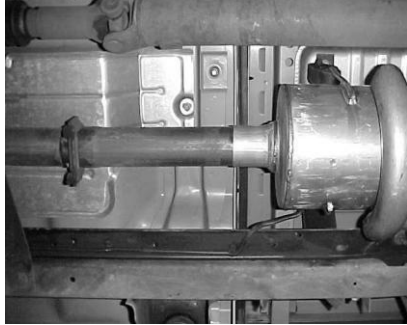

LAY OUT THE GIBSON EXHAUST AND COMPARE THE PART NUMBERS WITH THE MANUAL.

DO NOT REMOVE STOCK HEADPIPE

FOR 4WD- REMOVE STOCK MUFFLER AT SLIP JOINT 8" IN FRONT OF THE MUFFLER.

FOR 2WD- CUT 8" IN FRONT OF THE FACTORY MUFFLER AND REMOVE. FOR AN EASIER REMOVAL OF THE FACTORY EXHAUST, CUT JUST BEHIND THE REAR MUFFLER HANGER. LEAVE ALL THE FACTORY RUBBER GROMMETS IN PLACE.



UNBOLT AND REMOVE STOCK REAR HANGER ON THE PASSENGER SIDE OF THE FRAME RAIL. INSTALL HANGERS # H TO THE BOTTOM OF FRAME RAIL IN EXISTING HOLE APPROX. 22 .5" FROM THE REAR OF THE FRAME, USE NUT AND BOLT THAT ARE SUPPLIED. REPEAT THIS SAME PROCEDURE ON DRIVERSIDE. HANGER # H WILL AIM TOWARDS THE REAR OF THE VEHICLE.

INSTALL BAND CLAMP # I INTO RUBBER GROMMETS AND INSERT WELDED HANGER. ATTACH WITH BOLT KIT # L.

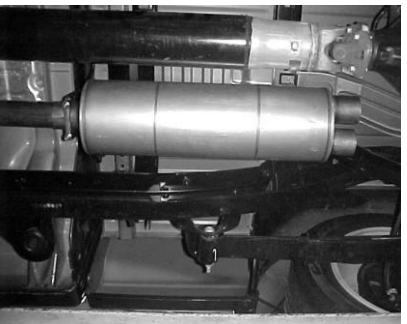

INSTALL MUFFLER # A WITH THE INLET TOWARDS THE MOTOR. INLET HAS LOUVERS INSIDE FACING TOWARDS THE MOTOR. USE A JACK STAND TO SUPPORT THE MUFFLER. USE CLAMP # F TO SECURE MUFFLER TO THE STOCK HEADPIPE. DO NOT TIGHTEN .



NEXT, INSTALL HANGER # G TO THE PASSENGER SIDE OF MUFFLER OUTLET WITH VERTICAL BAR OF THE HANGER TOWARDS PASSENGER SIDE. INSTALL PASSENGER SIDE OVERAXLE PIPE # D INTO MUFFLER AT LEAST 1 1/2" TO 2". AND USE CLAMP # F TO ATTACH.. DO NOT TIGHTEN



INSTALL DRIVERSIDE FRONT TAILPIPE # B INTO MUFFLER AT LEAST 1 1/2" TO 2". USING CLAMP # F. NEXT INSTALL DRIVERSIDE OVERAXLE PIPE # C TO FRONT TAILPIPE USING CLAMP # F. DO NOT TIGHTEN



INSTALL EXIT PIPES # E TO OVERAXLE PIPES USING CLAMP # F TO SECURE THEM. DO NOT TIGHTEN. INSTALL CLAMP # F TO HANGER # H ON BOTH SIDES TO HOLD UP YOUR TAILPIPES. ADJUST PIPES TO THE RIGHT ANGLE AND CUT IF NECESSARY TO LENGTH. IF YOUR VEHICLE HAS A SWAY BAR YOU MAY HAVE TO TRIM THE FACTORY BOLT ON THE PASSENGER SIDE



INSTALL STAINLESS TIPS. TIGHTEN ALL CLAMPS AND HANGERS STARTING FROM THE MUFFLER BACK.. USE ZIP TIES FOR BRAKE & VENT LINES.

MAKE SURE YOU HAVE A MINIMUM OF AT LEAST 1" OF CLEARANCE FROM ALL BRAKE LINES, SHOCKS, TIRES, ETC. SPARE TIRE MAY NEED TO BE LOOSENED AND PUSHED TO THE REAR OF THE TRUCK FOR BETTER CLEARANCE.