

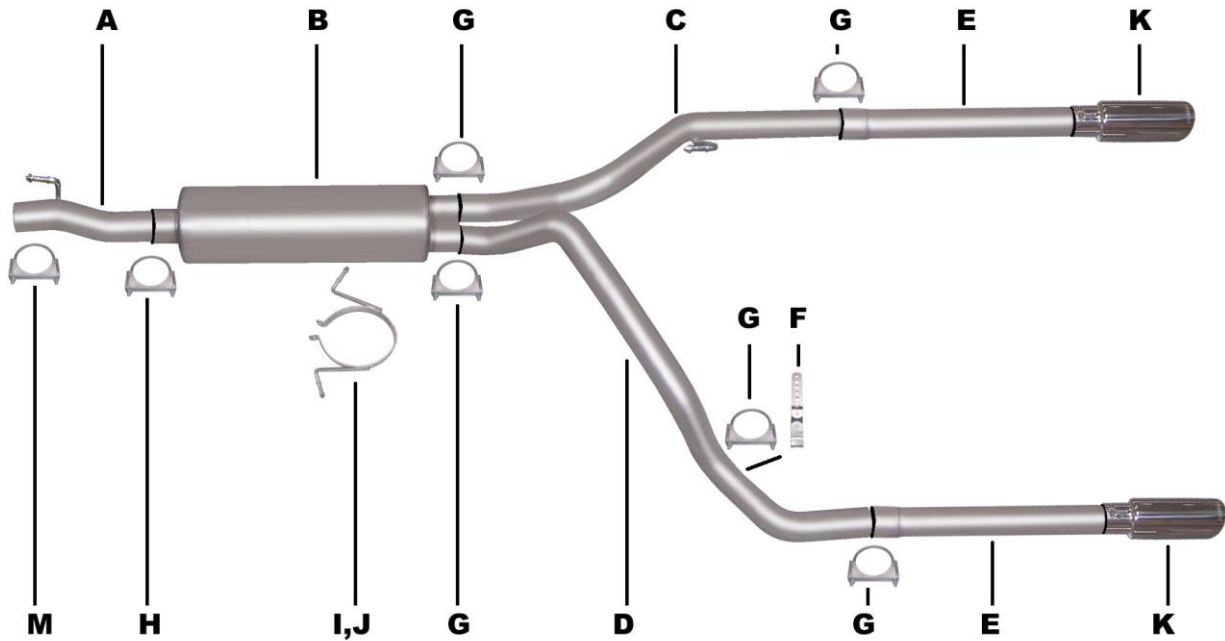

PERFORMANCE EXHAUST SYSTEMS

INSTRUCTION MANUAL
CAT-BACK STAINLESS SPLIT EXHAUST SYSTEM
DODGE RAM 1500 TRUCK 5.7L HEMI 2/4WD
QUAD CAB, SHORT BED 4DR
PART # 66524



ITEM	PART #	QTY.	DESCRIPTION
A	787-700546S	1	3" STAINLESS EXTENSION HEADPIPE
B	789800S	1	STAINLESS SUPERFLOW MUFFLER
C	550-700411S	1	2-1/2" STAINLESS PASSENGER SIDE OVERAXLE PIPE
D	612-700408S-1	1	2-1/2" STAINLESS DRIVERSIDE OVERAXLE PIPE
E	546-700346S	2	2-1/2" STAINLESS EXIT PIPE
F	08269	1	10" HANGER
F	BO-101	1	BOLT KIT FOR 10" HANGER
G	5757	5	2-1/2" CLAMP
H	OHD300	1	3" CLAMP
I	4188	1	BAND CLAMP
J	BO-1015	1	BAND CLAMP BOLT KIT
K	500374	2	3 1/2" STAINLESS TIPS
L	ZIP	2	ZIP TIES
M	5758	1	2.75" CLAMP

EXHAUST INSTALLATION #66524

WHEN INSTALLING THIS EXHAUST SYSTEM MAKE SURE TO USE ALL THE PROPER SAFETY PRECAUTIONS. USE JACK STANDS WHEN UNDER TRUCK, SET PARKING BRAKE, BLOCK TIRES AND USE SAFETY GLASSES AND GLOVES. **DO NOT WORK WITH HOT PIPES!**

SUGGESTED TOOLS:

9/16, 1/2, 15MM Wrench and Socket, Jack Stand, Hacksaw, WD-40

TO REMOVE STOCK EXHAUST UNCLAMP THE STOCK EXHAUST JUST IN FRONT OF THE MUFFLER



YOU MAY NEED TO HEAT IT UP FOR EASIER REMOVAL. LEAVE ALL RUBBER GROMMETS IN PLACE. USE WD-40 FOR REMOVAL OF HANGERS.



MEASURE 19 1/2" FROM THE REAR OF THE FRAME AND USE THIS HOLE AND BOLT ON HANGER #F. USE THE 3RD HOLE FROM THE TOP.



INSTALL HEADPIPE #A, YOU WILL NEED TO LINE UP THE TWO NOTCHES. INSERT HANGER INTO RUBBER GROMMET. DO NOT TIGHTEN. USE CLAMP #M TO SECURE HEADPIPE TO YOUR STOCK PIPE.

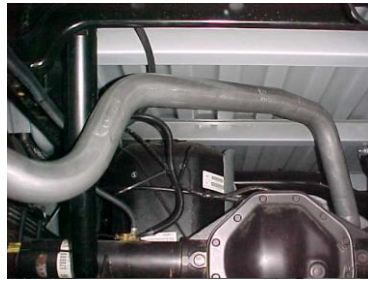

SPARE TIRE MAY NEED TO BE LOOSENED AND PUSHED TO THE REAR OF THE TRUCK FOR BETTER CLEARANCE.

INSTALL DRIVER SIDE TAILPIPE #D INTO MUFFLER 1-1/2" TO 2" AND USE CLAMP #G TO SECURE THE MUFFLER. DO NOT TIGHTEN. USE CLAMP #G TO HOLD PIPE UP TO THE HANGER #F. DO NOT TIGHTEN.

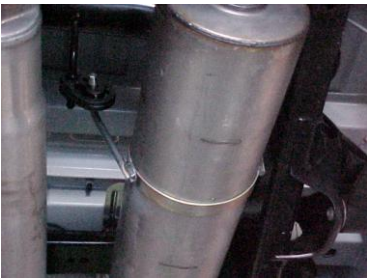

INSTALL MUFFLER #B ONTO HEADPIPE 1-1/2" TO 2". USE CLAMP #H TO SECURE THE MUFFLER TO THE HEADPIPE. DO NOT TIGHTEN. SLIDE BAND CLAMP #I ONTO THE MUFFLER AND INSERT THE WELDED HANGER INTO THE RUBBER GROMMET AND ATTACH WITH BOLT KIT #J.



INSTALL THE EXIT PIPES #E ONTO THE TAILPIPES USING CLAMPS #G. ROLL THE PIPES UNTIL YOU HAVE THEM AT THE ANGLE YOU DESIRE.



INSTALL PASSENGER SIDE TAILPIPE #C INTO MUFFLER 1-1/2" TO 2". USE CLAMP #G TO SECURE TAILPIPE TO MUFFLER. INSERT WELDED HANGER INTO RUBBER GROMMET. DO NOT TIGHTEN.



NOW GO BACK AND TIGHTEN ALL CLAMPS, NUTS AND BOLTS STARTING FROM THE FRONT AND WORKING BACK. INSTALL STAINLESS TIPS. USE ZIP TIES FOR BRAKE LINES, WIRES, ETC.

ADJUST KIT FOR PROPER EXIT PIPE ANGLE. DO NOT TIGHTEN ANY CLAMPS UNTIL ADJUSTMENT IS DONE!! MAKE SURE YOU HAVE A 1" CLEARANCE AWAY FROM ALL PIPES, BRAKE LINES. FUEL LINES. SHOCKS. TIRES. ETC...