

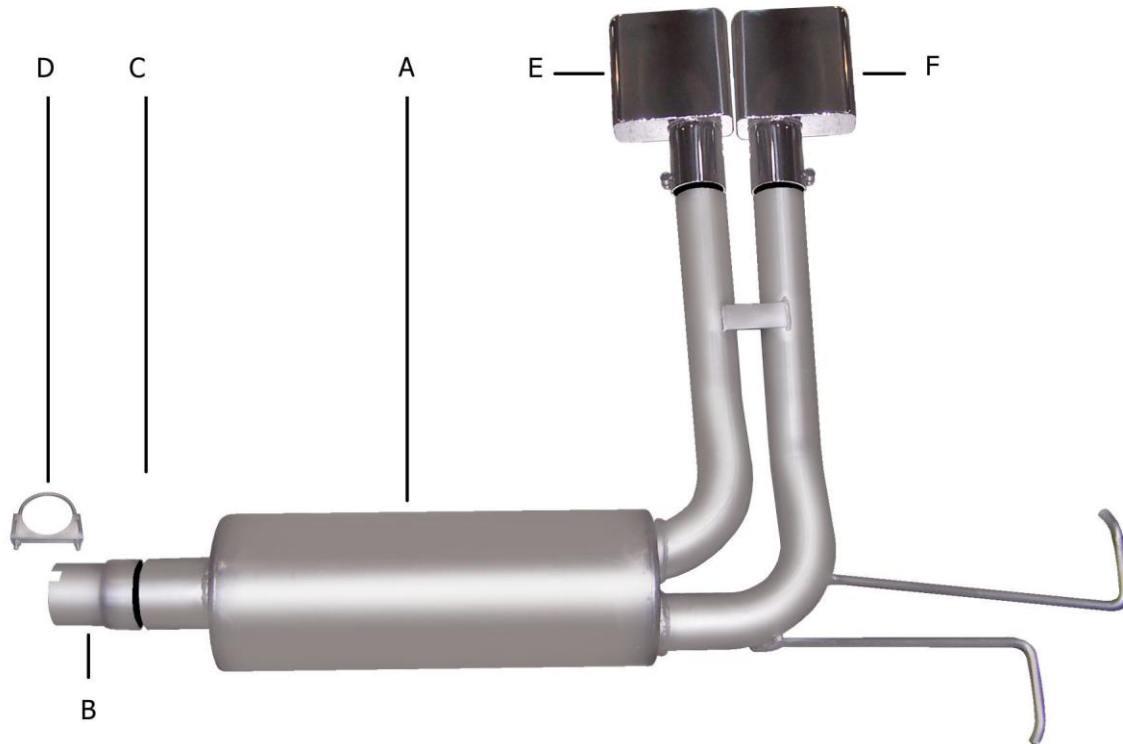

PERFORMANCE EXHAUST SYSTEMS

**INSTRUCTION MANUAL
SUPER TRUCK EXHAUST SYSTEM
DODGE TRUCK 3.9L, 5.2L, 5.9L 2/4WD
STANDARD CAB & EXTENDED CAB, SHORT & LONG BED
PART # 6510**



ITEM	PART #	QUANTITY	DESCRIPTION
A	700112	1	MUFFLER ASSEMBLY
B	30020	1	3" HEADPIPE
C	0HD300	1	3" CLAMP
D	5757	1	2-1/2" CLAMP
E	500365	1	SUPER TRUCK TIP
F	500366	1	SUPER TRUCK TIP

94'-97' WILL NOT FIT IF PSGR. SHOCK IS BEHIND THE REAR AXLE
98'-01' WILL NOT FIT WITH TWO CONVERTERS.

EXHAUST INSTALLATION SHEET #6510

WHEN INSTALLING THIS EXHAUST SYSTEM, MAKE SURE TO USE PROPER SAFETY PRECAUTIONS. USE JACK STANDS WHEN UNDER THE TRUCK, SET PARKING BRAKE, BLOCK TIRES, AND USE SAFETY GLASSES AND GLOVES. DO NOT WORK WITH HOT PIPES!

SUGGESTED TOOLS:

HACKSAW, 9/16" SOCKET, 1/2" SOCKET, 1/2" WRENCH, JACKSTAND, WD-40

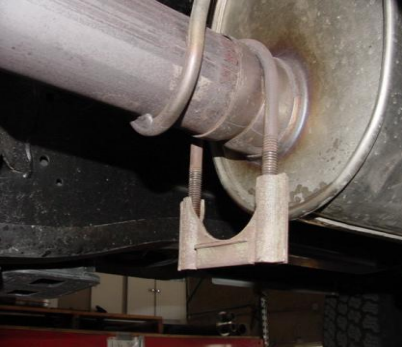

TO REMOVE STOCK EXHAUST UNCLAMP IT FROM THE CLAMP LOCATED JUST IN FRONT OF YOUR STOCK MUFFLER. YOU MAY NEED TO HEAT IT UP WITH A TORCH TO REMOVE IT. NOW CUT OFF YOUR STOCK TAILPIPE JUST BEHIND THE MUFFLER AND REMOVE. LEAVE ALL RUBBER GROMMETS ON THE HANGER. USE WD-40 TO AID IN REMOVAL OF EXHAUST AND HANGERS.

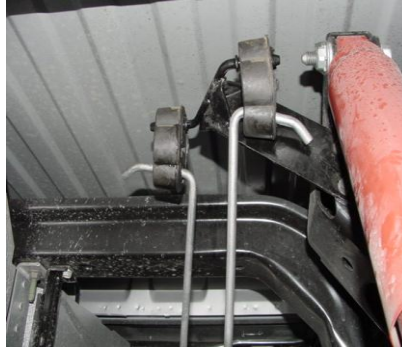

INSTALL MUFFLER ASSEMBLY #B ONTO HEADPIPE 1-1/2" TO 2". SLIDE WELDED HANGERS INTO RUBBER GROMMETS YOU MAY NEED TO ADJUST WELDED HANGERS TO FIT INTO YOUR GROMMETS. USE A JACKSTAND TO SUPPORT YOUR MUFFLER. USE CLAMP #C TO SECURE IT TO YOUR HEADPIPE. DO NOT TIGHTEN.



INSTALL HEADPIPE #A, LINE UP THE NOTCH USE CLAMP #D TO SECURE HEADPIPE TO YOUR FACTORY PIPE. DO NOT TIGHTEN.



INSTALL YOUR STAINLESS TIPS. TIGHTEN ALL CLAMPS AFTER YOU MAKE SURE YOUR TAILPIPES ARE LEVEL.