

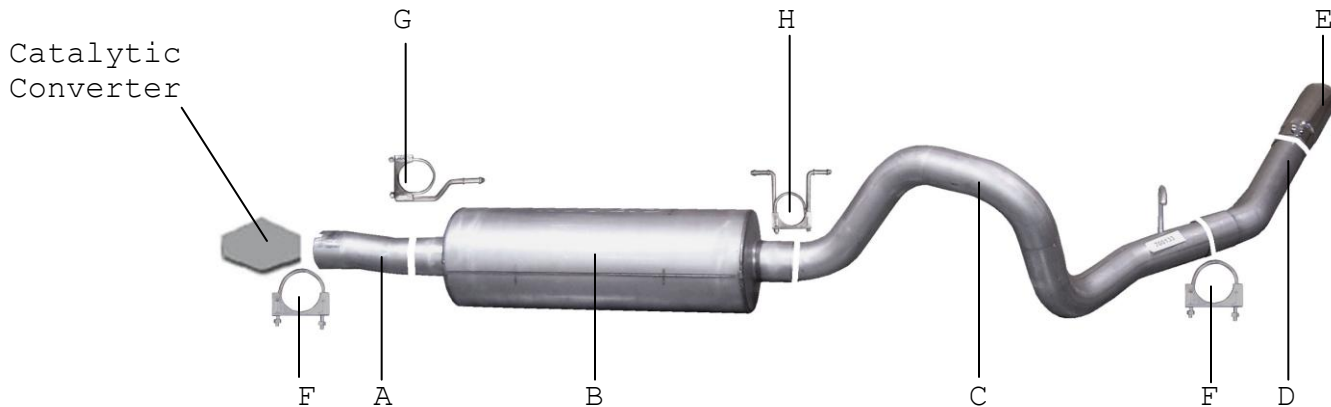

# INSTRUCTION MANUAL

CAT-BACK SINGLE STAINLESS EXHAUST  
FORD EXCURSION 5.4L, 6.8L 4DR 2/4WD  
PART # 619995



ITEM	PART#	QUANTITY	DESCRIPTION
A	398-700257S	1	3" STAINLESS HEADPIPE
B	420887	1	SUPERFLOW STAINLESS MUFFLER
C	233-700133S	1	3" STAINLESS TAILPIPE
D	114-500622S	1	3" STAINLESS TURNOUT PIPE
E	500360	1	3-1/2" STAINLESS TIP
F	OHD300	2	3" CLAMP
G	40096	1	O.E.FRONT MUFFLER HANGER
H	40097	1	O.E.REAR MUFFLER HANGER

# EXHAUST INSTALLATION PART #619995

WHEN INSTALLING THE EXHAUST SYSTEM, MAKE SURE TO USE PROPER SAFETY PRECAUTIONS. USE JACK STANDS WHEN UNDER VEHICLE, SET PARKING BRAKE, BLOCK TIRES AND USE SAFETY GLASSES AND GLOVES. DO NOT WORK WITH HOT PIPES !

## SUGGESTED TOOLS:

9/16" SOCKET, 1/2" SOCKET, 1/2" WRENCH, HACKSAW, JACKSTAND

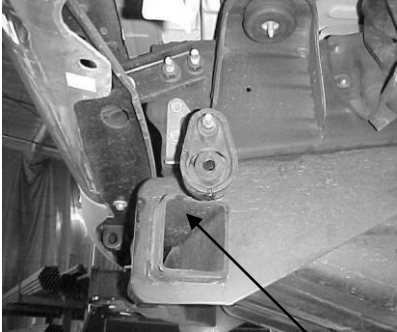

LAY OUT GIBSON EXHAUST ON THE FLOOR LIKE THE DRAWING. CHECK ALL PIPE NUMBERS TO MANUAL NUMBERS SO THEY MATCH. REMOVE OLD EXHAUST BY CUTTING THE TAILPIPE OFF AT THE OUT LET OF THE MUFFLER WITH A HACKSAW.

UNCLAMP THE MUFFLER ASSEMBLY JUST IN FRONT OF THE STOCK MUFFLER AND REMOVE. REMOVE THE FACTORY REAR HANGER UNDERNEATH THE REAR BUMPER. LEAVE FACTORY RUBBER GROMMETS IN PLACE.



INSTALL OVERAXLE #C INTO THE OUTLET OF THE MUFFLER NO LESS THEN 1-1/2" AND NO MORE THEN 2". USING CLAMP #H. INSERT WELDED HANGER INTO RUBBER GROMMET. SLIP TURNOUT PIPE #D ONTO OVERAXLE PIPE AND INSTALL WITH CLAMP #F. DO NOT TIGHTEN.

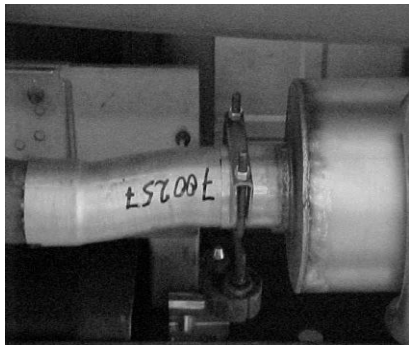

SLIP HEADPIPE #A ONTO THE STOCK EXTENSION PIPE BEHIND THE CONVERTER. ALIGN NOTCH WITH STOCK HEADPIPE PIN. SLIP MUFFLER WITH THE LOUVERS INSIDE OF THE MUFFLER FACING FORWARD ONTO HEADPIPE #A NO LESS THEN 1-1/2" AND NO MORE THEN 2". THEN INSTALL FRONT MUFFLER HANGER #G AND REAR MUFFLER HANGER # H. DO NOT TIGHTEN. USE A JACKSTAND TO SUPPORT THE MUFFLER. MUFFLER INLET IS LOOKING INTO THE LOUVERS.



INSTALL THE STAINLESS STEEL TIP TO YOUR DESIRED LOOK. USE ANY ALUMINUM OR STAINLESS STEEL CLEANER TO POLISH YOUR TIP. TURN VEHICLE ON AND CHECK FOR LEAKS. NOW TIGHTEN ALL CLAMPS AND MAKE SURE ALL HANGERS ARE IN THE CORRECT PLACE.

**MAKE SURE YOU HAVE AT LEAST A 1" CLEARANCE ON ALL PIPES FROM BRAKE LINES, FUEL LINES, TIRES, SHOCK BOOTS, ETC.**