



INSTRUCTION MANUAL

CAT-BACK SINGLE STAINLESS EXHAUST SYSTEM

CHEVY SUBURBAN 5.7L, 7.4L 2/4WD

PART # 615590

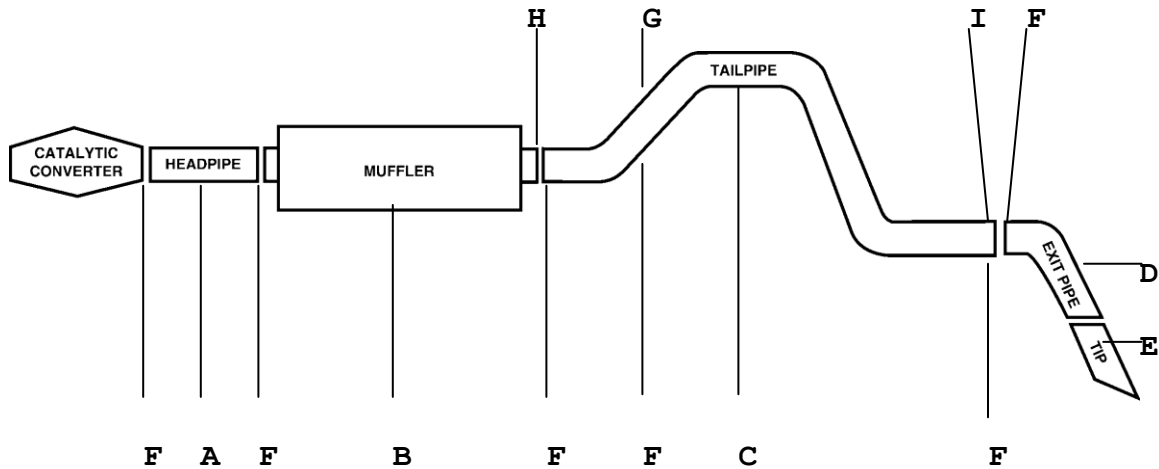

ITEM	PART #	QUANTITY	DESCRIPTION
A	201-42206S	1	3" FRONT STAINLESS EXTENSION PIPE
B	420887	1	GIBSON STAINLESS MUFFLER
C	141-50033LS	1	3" OVERAXLE STAINLESS TAILPIPE
D	117-50032RS	1	3" TURNOUT STAINLESS PIPE
E	500360	1	3-1/2" STAINLESS TIP
F	OHD300	6	3" CLAMP
G	BO-101	1	BOLT KIT FOR HANGER
G	08269	1	10" HANGER
H	500551*	1	REAR MUFFLER HANGER
I	500444*	1	REAR TAILPIPE HANGER

*** ON SOME MODELS, MAINLY 4WD, YOU WILL USE THESE HANGERS AS NEEDED. YOU MAY ALSO NEED TO CUT ITEM "B", TAILPIPE: CUT 6-1/2" OFF FRONT OF TAILPIPE, AND ITEM "F", HEADPIPE: CUT 6" OFF REAR.**

EXHAUST INSTALLATION #615590

WHEN INSTALLING THIS EXHAUST SYSTEM MAKE SURE TO USE PROPER SAFETY PRECAUTIONS. USE JACK STANDS WHEN UNDER THE TRUCK, SET PARKING BRAKE, BLOCK TIRES, AND USE SAFTEY GLASSES AND GLOVES. DO NOT WORK WITH HOT PIPES!

1. Raise vehicle and support with stands. Remove stock hangers leaving all rubber mounting grommets in place. Cut the stock tailpipe for easy removal.
2. Lay out the GIBSON EXHAUST SYSTEM on the floor so it looks like the drawing with hangers in the proper place.
3. Connect headpipe #A behind the stock converter. Use jack stands to support converter so it won't drop and connect with clamp # F.
4. Connect muffler # B with inlet towards the converter to the headpipe. Use a jack stand to support the muffler and connect with clamp # F. Attach rear muffler hanger # H. Muffler inlet is looking into the louvers.
5. Install the overaxle tailpipe # C, connect to the muffler and connect with clamp # F. Install hanger # G and # I tailpipe.
6. Connect turnout exit pipe # D to the rear of the overaxle pipe. Roll turnout pipe until you have it at the correct angle for your truck and connect with clamp # F.
7. Install stainless tip. Clamp down. To clean stainless tip use a scott brite pad and any stainless steel or aluminum cleaner.
8. When you have everything in place, firmly tighten all bolts and clamp down securely.

MAKE SURE YOU HAVE A 1" CLEARANCE ON ALL PIPES FROM ALL RUBBER BRAKE LINES, FUEL LINES, SHOCK BOOTS, TIRES, ETC.

LOWERED TRUCKS WITH A 4" DROP OR MORE MAY NEED TO NOTCH BOTTOM RAIL OF BED. SOME 88-89 CHEVY TRUCKS HAVE A REAR CONVERTER WHICH SHOULD BE RE-INSTALLED BACK INTO STOCK LOCATION.