



# INSTRUCTION MANUAL

## CAT-BACK DUAL SPORT EXHAUST

### SILVERADO, SIERRA 1500 TRUCK

EXTENDED CAB, SHORT BED 4.3L, 4.8L, 5.3L 2/4WD

EXTENDED CAB, SHORT BED QUAD STEER 5.3L 2WD

CREW CAB, SHORT BED 1500 NON-HD 5.3L 2/4WD

1500 CLASSIC, CREW CAB, SHORT BED 4.8L, 5.3L 2/4WD

1500 CLASSIC, EXT CAB, STANDARD BED 4.3L, 4.8L, 5.3L 2/4WD

## PART #5300

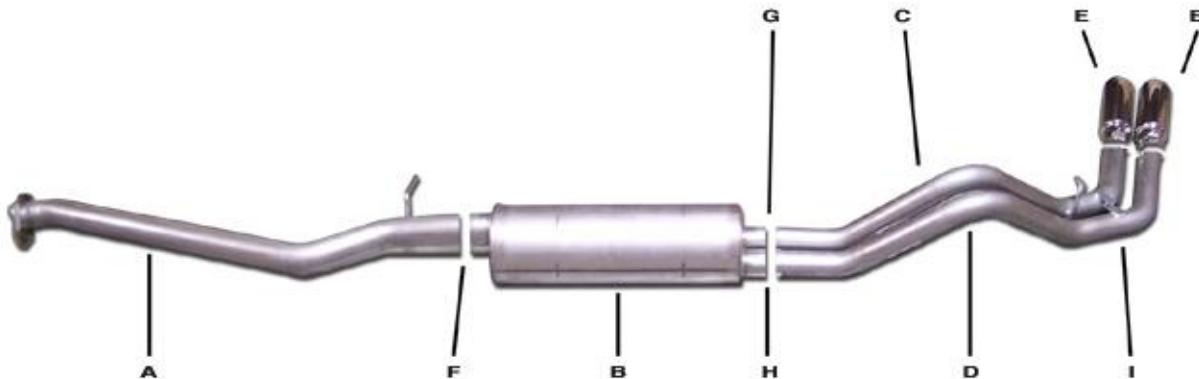

ITEM	PART #	QTY	DESCRIPTION
A	700394	1	3" HEADPIPE WITH FLANGE #GP-115
B	758250	1	SUPERFLOW MUFFLER
C	700395	1	2.5" PASSENGER SIDE OVERAXLE PIPE
D	700396	1	2.5" DRIVERSIDE OVERAXLE PIPE
E	500374	2	3 1/2" STAINLESS TIPS
F	OHD300	1	3" CLAMP
G	5757	1	2-1/2" CLAMP
H	4149	1	REAR MUFFLER HANGER
I	BO-906	1	BOLT KIT FOR TAILPIPE

# EXHAUST INSTALLATION

## PART# 5300

WHEN INSTALLING THIS EXHAUST SYSTEM MAKE SURE TO USE ALL THE PROPER SAFETY PRECAUTIONS. USE JACK STANDS WHEN UNDER TRUCK, SET PARKING BRAKE, BLOCK TIRES AND USE SAFETY GLASSES. **DO NOT WORK WITH HOT PIPES!!!**

### SUGGESTED TOOLS

15mm SOCKET, 9/16" SOCKET, 1/2" SOCKET, 1/2" WRENCH, JACK STAND, WD-40

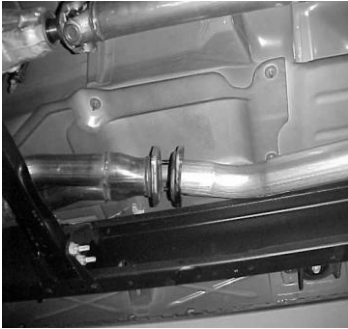

LAY OUT THE GIBSON EXHAUST ON THE FLOOR SO IT LOOKS LIKE THE DRAWING. AND COMPARE PARTS WITH MANUAL. UN-BOLT THE STOCK FLANGE BEHIND FACTORY Y-PIPE. **KEEP THE STOCK BOLTS,NUTS FOR YOU WILL RE-USE THEM.**

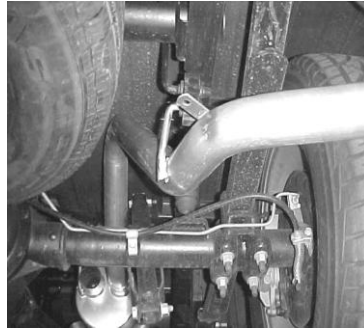

MAKE SURE MUFFLER OUTLETS ARE LEVEL BEFORE INSTALLING TAILPIPES. NOW INSTALL PASSENGER TAILPIPE #C. INSERT WELED HANGER INTO RUBBER GROMMET.

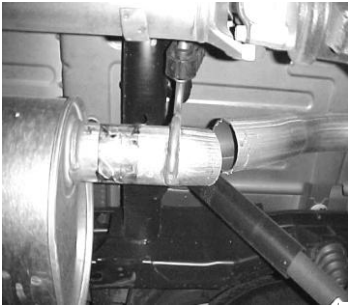

FOR EASIER REMOVAL OF THE STOCK EXHAUST CUT THE TAIL PIPE BEHIND YOUR MUFFLER. LUBE ALL RUBBER GROMMETS WITH WD-40. LEAVE ALL YOUR STOCK RUBBER GROMMETS IN PLACE.



NOW INSTALL DRIVERSIDE TAILPIPE #D. THE SPARE TIRE MAY NEED TO BE LOOSENED AND PUSHED TO THE DRIVER SIDE TO ALLOW FOR CLEARANCE. USE BOLT KIT # I TO ATTACH BOTH TAILPIPES TOGETHER. DRIVERSIDE TAILPIPE BRACKET WILL BE POSITIONED ON TOP OF PASSENGER TAILPIPE BRACKET.



BOLT HEADPIPE # A TO YOUR STOCK FLANGE RE-USING FACTORY BOLTS. AND NUTS. DO NOT TIGHTEN INSERT WELDED HANGER INTO RUBBER GROMMET.

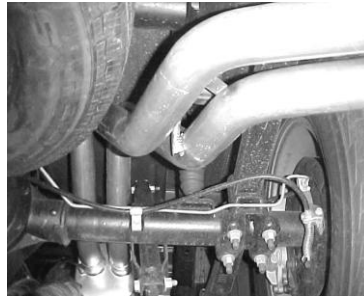

USING CLAMP #G & HANGER # H CONNECT BOTH TAILPIPES TO THE OUTLETS OF THE MUFFLER. ROTATE TAILPIPES TO BEST FIT YOUR TRUCK.



INSTALL MUFFLER # B WITH INLET TOWARDS Y-PIPE, WITH THE OUTLETS POSITIONED AT THE TOP OF THE MUFFLER. USE A JACK STAND TO SUPPORT THE MUFFLER. USE CLAMP #F TO CONNECT THE MUFFLER TO HEADPIPE. INSTALL HANGER # H ONTO THE DRIVERSIDE OUTLET OF THE MUFFLER. INSERT THE WELDED HANGER INTO THE RUBBER GROMMET FROM THE PASSENGER SIDE. DO NOT TIGHTEN.



INSTALL YOUR STAINLESS STEEL TIPS TO YOUR DESIRED LOOK. USE ANY STAINLESS OR ALIUMINUM CLEANER TO POLISH YOUR TIPS. NEXT GO BACK AND TIGHTHEN ALL BOLTS, CLAMPS, HANGERS AND FLANGE BOLTS.