

(12) **United States Patent**
Borkholder

(10) **Patent No.:** **US 9,505,281 B1**
(45) **Date of Patent:** **Nov. 29, 2016**

(54) **ADJUSTABLE TORSION HITCH RECEIVER**

(71) Applicant: **Carl Borkholder**, Bremen, IN (US)

(72) Inventor: **Carl Borkholder**, Bremen, IN (US)

(*) Notice: Subject to any disclaimer, the term of this patent is extended or adjusted under 35 U.S.C. 154(b) by 0 days.

(21) Appl. No.: **14/931,415**

(22) Filed: **Nov. 3, 2015**

(51) **Int. Cl.**
B60D 1/50 (2006.01)
B60D 1/24 (2006.01)
B60D 1/52 (2006.01)

(52) **U.S. Cl.**
CPC . **B60D 1/50** (2013.01); **B60D 1/24** (2013.01);
B60D 1/248 (2013.01); **B60D 1/52** (2013.01)

(58) **Field of Classification Search**
CPC B60D 1/50
See application file for complete search history.

(56) **References Cited**

U.S. PATENT DOCUMENTS

4,792,154 A *	12/1988	Kerst	B60D 1/50 280/489
6,494,478 B1 *	12/2002	MacKarvich	B60D 1/06 177/136
7,775,544 B2 *	8/2010	Bouwkamp	B60D 1/143 280/483
D682,751 S *	5/2013	Borkholder	D12/162
D697,838 S *	1/2014	Borkholder	D12/162
D727,803 S *	4/2015	Borkholder	D12/162
2003/0178811 A1	9/2003	Buckner	

* cited by examiner

Primary Examiner — Kevin Hurley

(74) *Attorney, Agent, or Firm* — Botkin & Hall, LLP

(57) **ABSTRACT**

A torsion hitch receiver is provided having a draw bar that is adapted to be received by a vehicle mounted receiver. The torsion hitch receiver has an upper and lower torsion assembly with arms that are linked to a receiver assembly. The receiver assembly has an array of receivers that are sized to receive an accessory draw bar. Applying a downward force to the receiver assembly causes rotation of the arms.

18 Claims, 5 Drawing Sheets

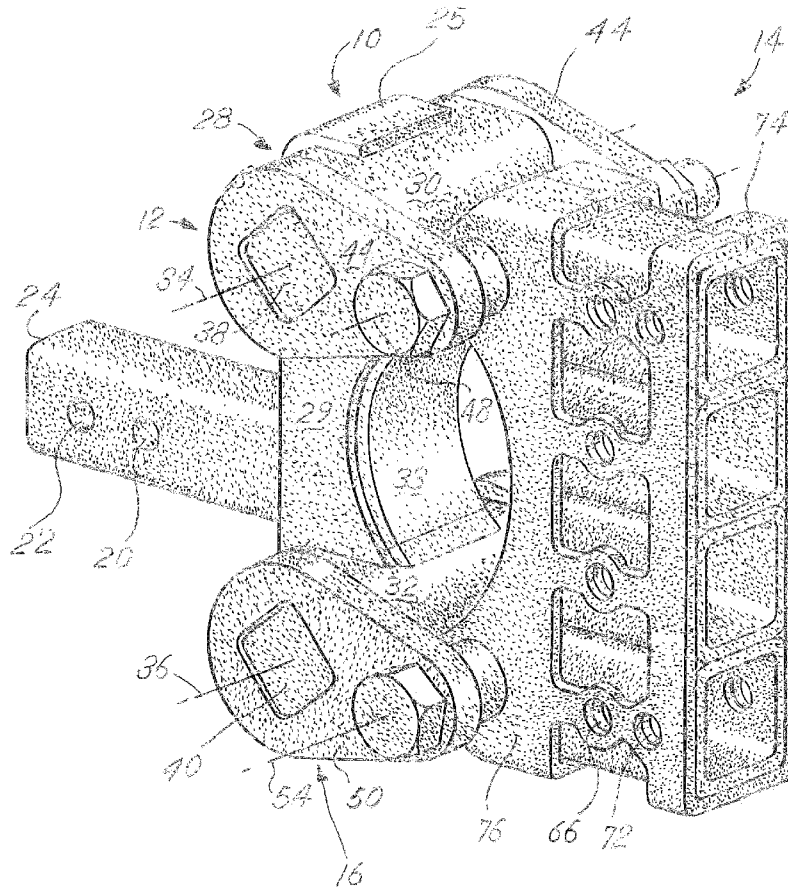
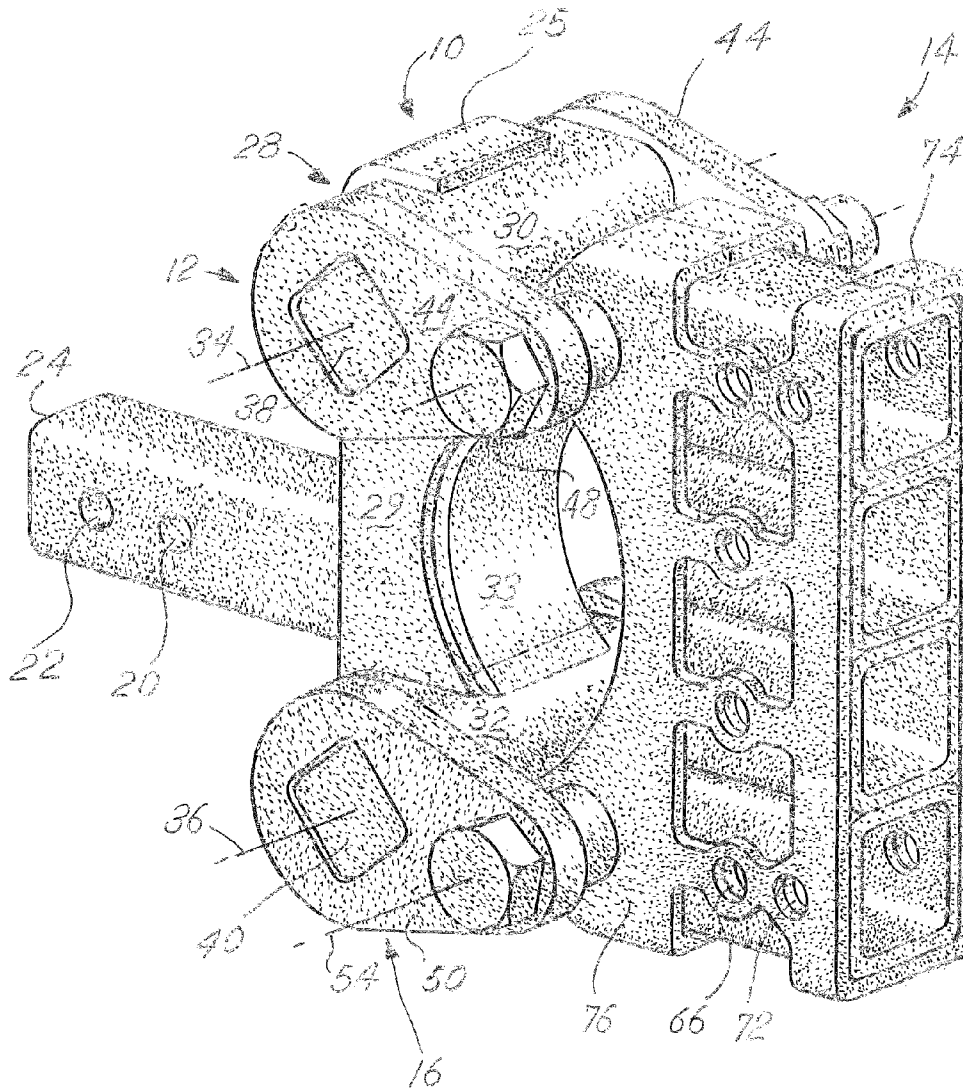

FIG 1



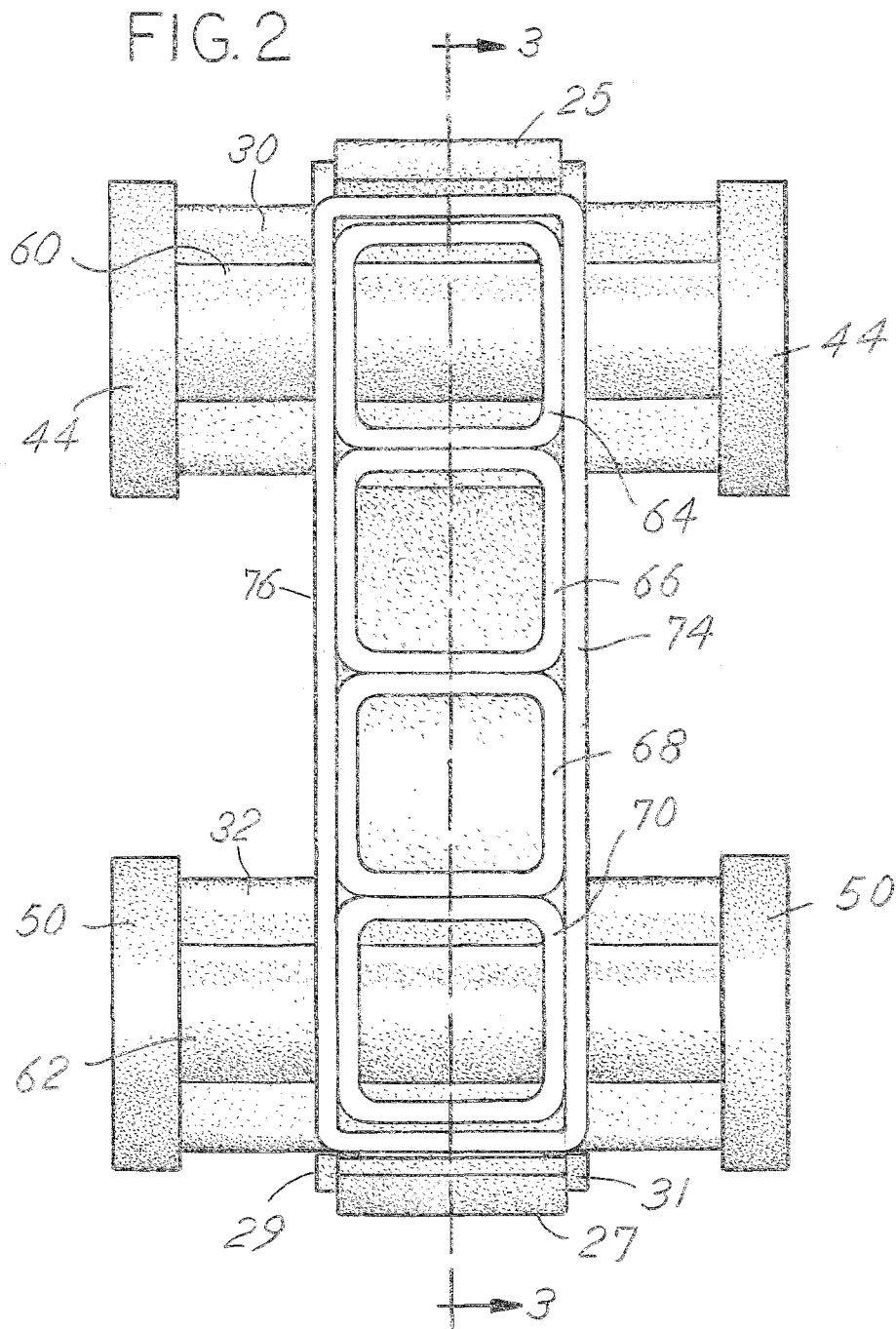
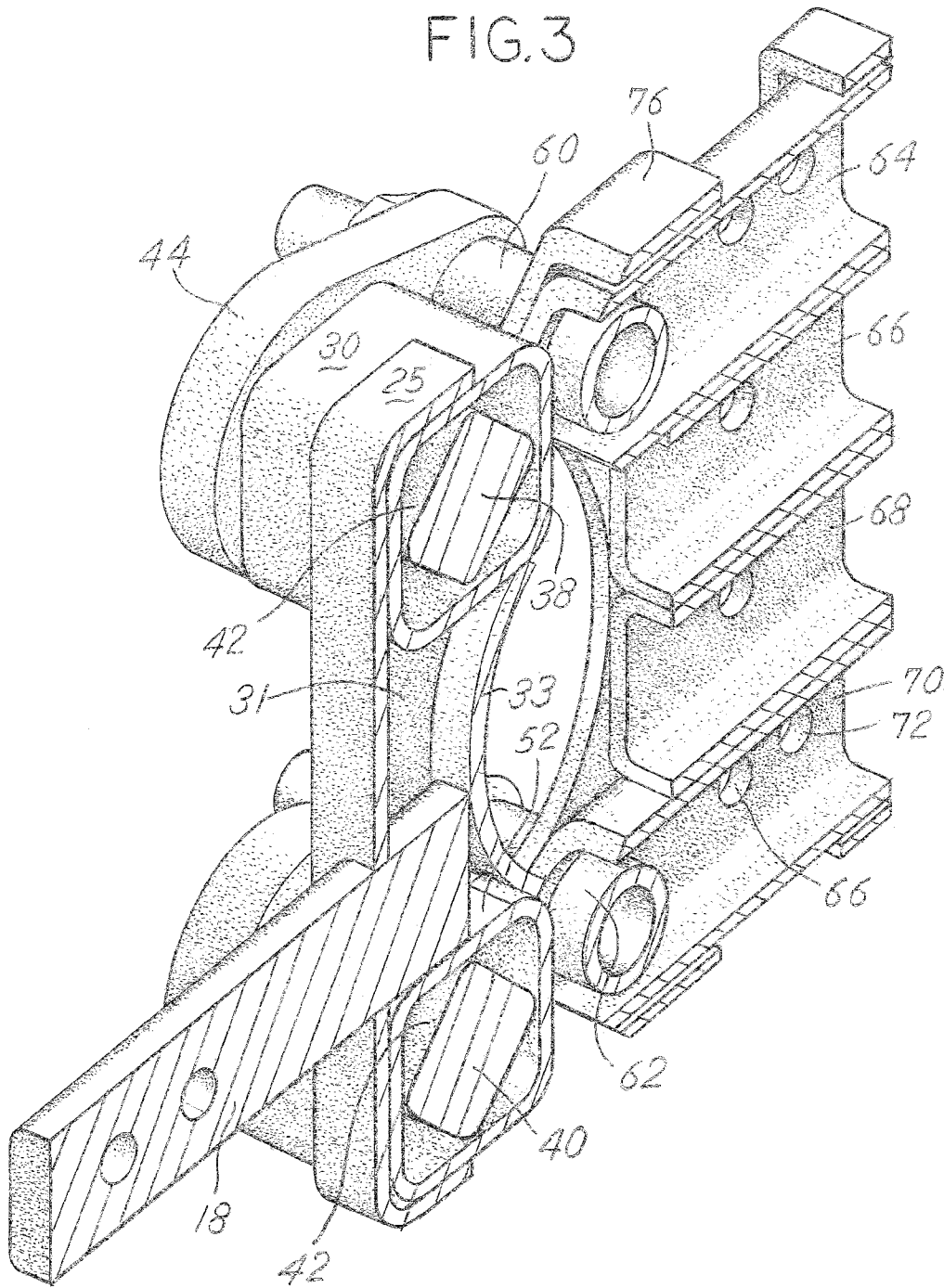

FIG. 3



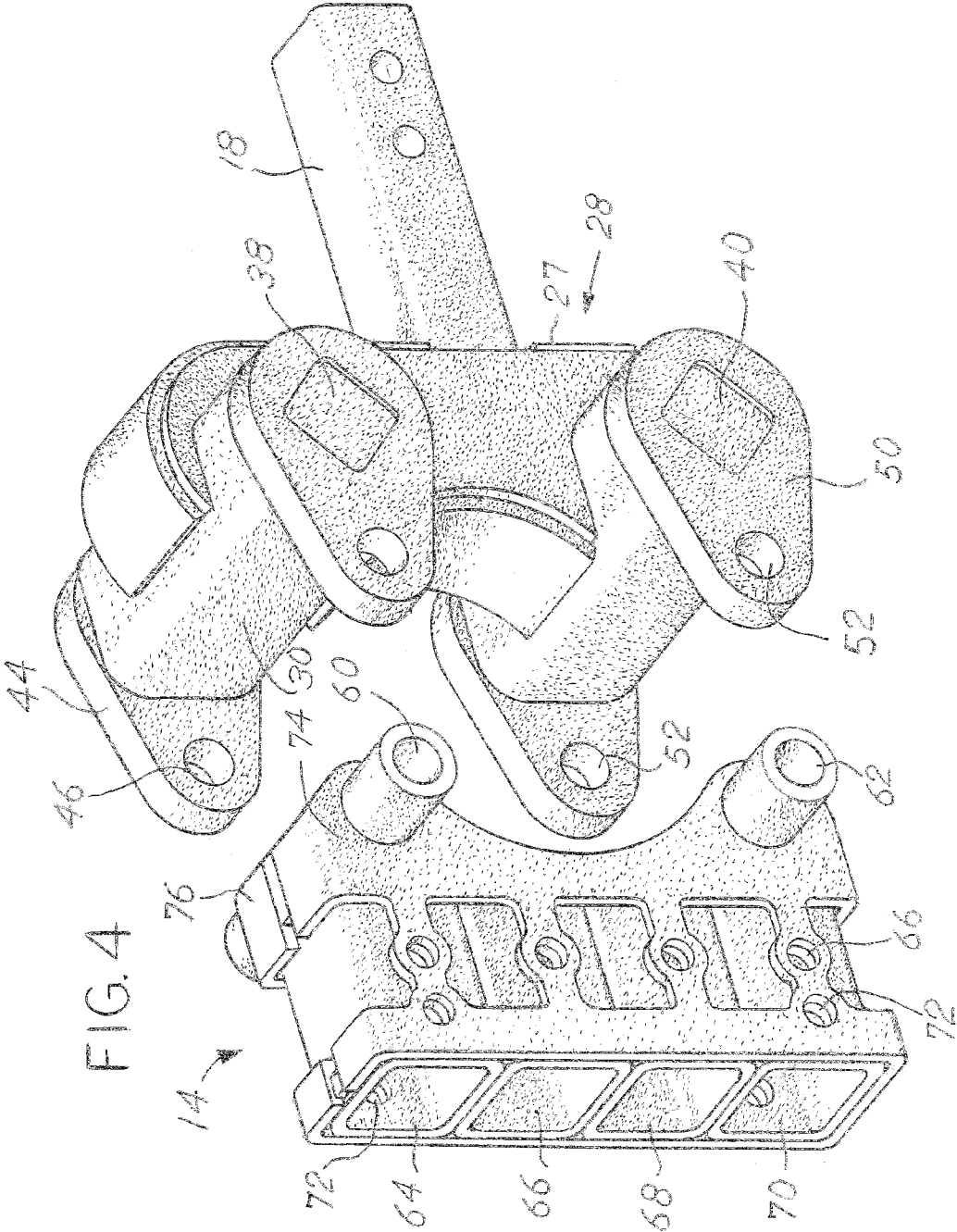
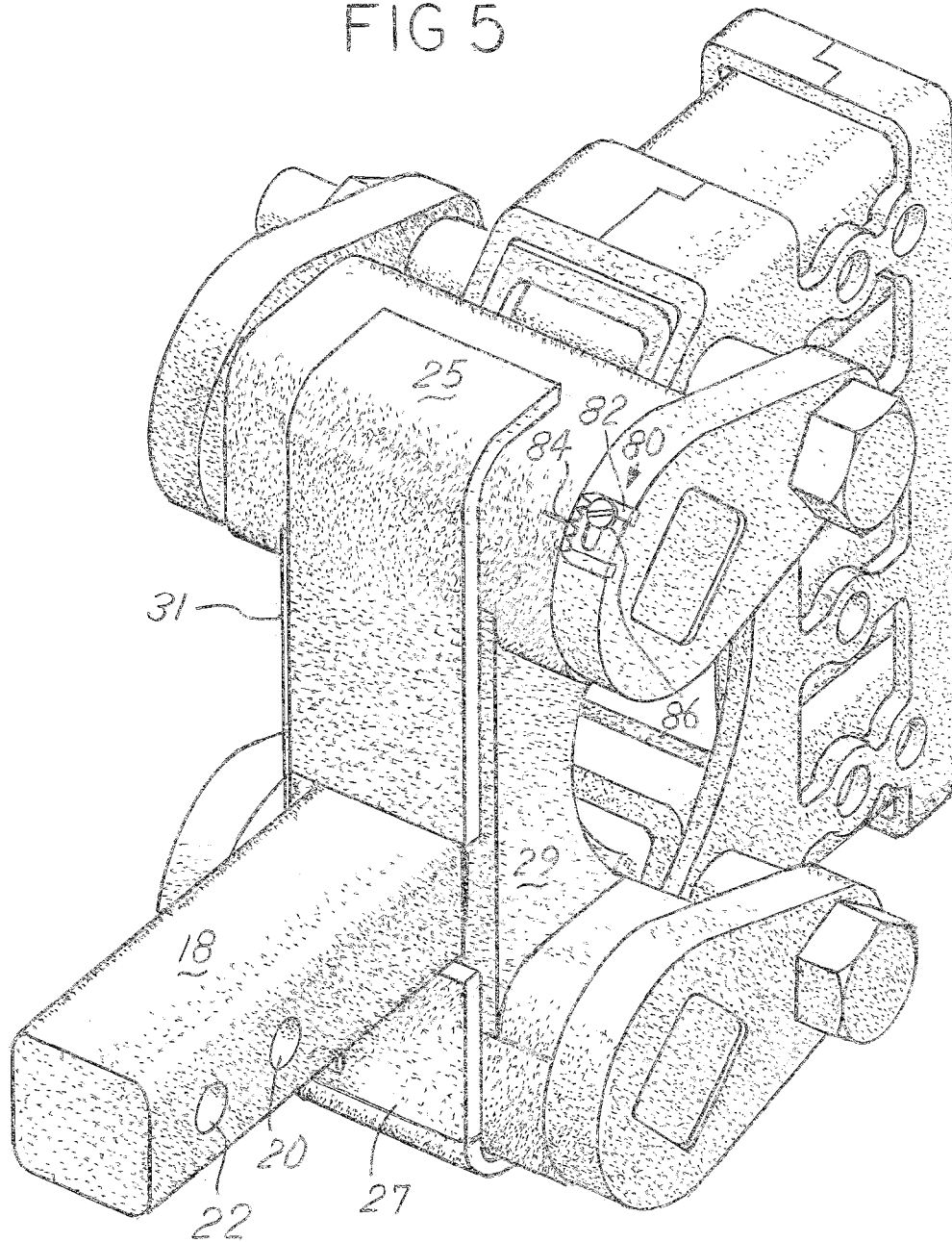

FIG 5



ADJUSTABLE TORSION HITCH RECEIVER

BACKGROUND OF THE INVENTION

This present disclosure relates to hitch receivers and the attachment between a trailer and a towing vehicle. Commonly, when being towed by a vehicle, the trailer is subject to transient forces as the towing vehicle pulls the trailer over various terrain or when loads are moved or placed on the trailer. Trailers have a tongue weight that is borne by the towing vehicle. Some tongue weight is necessary but it is desirable to limit the amount transmitted to the towing vehicle. The transient forces on the trailer can translate to transient tongue forces transmitted to the towing vehicle, at the very least, can be unsettling to the driver. In an extreme enough situation, the transient tongue forces can create a dangerous loss of control. An improved receiver that can be located between the trailer and the towing vehicle is necessary.

SUMMARY OF THE INVENTION

The present disclosure describes a torsion hitch receiver that will attach to a towing vehicle and absorb transient tongue loading either caused by the towing vehicle or the trailer. By implementing a torsion device, the hitch receiver allows for limited relative vertical motion between the towing vehicle and the trailer. The hitch receiver has multiple receiver holes that are vertically stacked to give the user several options of where to connect up a ball. The vertical stacking is frequently necessary when the trailer tongue height varies from trailer to trailer, and also the height of the receiver on different towing vehicles is different. An optional indicator measures the displacement between a loaded position and an unloaded position to allow the user to monitor tongue loading.

BRIEF DESCRIPTION OF THE DRAWINGS

A preferred embodiment of this invention has been chosen wherein:

- FIG. 1 is an isometric view of the receiver;
- FIG. 2 is a front view of the receiver;
- FIG. 3 is an isometric view 3-3 of the receiver in FIG. 2;
- FIG. 4 is a partially exploded isometric view of the receiver; and
- FIG. 5 is a rear isometric view of the receiver.

DESCRIPTION OF THE PREFERRED EMBODIMENT

A torsion hitch receiver 10, as shown in FIG. 1, has a fixed portion 12 and a moveable receiver portion 14. The two are connected to the fixed portion with a rotatable torsion portion 16.

The fixed portion 12 has an elongate draw bar 18 with a series of transverse holes 20, 22 near an end 24. The draw bar 18 has a central axis 19 and is sized to fit into a receiver in a towing vehicle (not shown). The draw bar 18 is affixed to the receiver on the towing vehicle with a pin that fits through existing holes in the receiver and one of the transverse holes 20, 22 in the draw bar 18. The use of a pin to connect to a receiver is well known in the art and the pin that fits through the receiver is not shown. A torsion housing 26 is affixed to the other end of the draw bar 18.

The torsion housing 26 has a main body portion 28 where it is affixed to the draw bar 18. The main body portion 28 is

an assembly of a series of flat or bent sheet metal that is welded or affixed together to form a single structural component. There is an upper back piece 25, a lower back piece 27, side pieces 29, 31, and a front curved piece 33. In addition to the bent and flat sheet metal are torsion tubes 30, 32. There is an upper torsion tube 30 and a lower torsion tube 32 affixed to the main body portion 28, as shown in FIG. 1. Each torsion tube 30, 32 is mostly square and has a central axis 34, 36 that is perpendicular to the draw bar 18. The central axis 34 of the upper tube 30 is parallel to the central axis 36 of the lower tube 32.

Residing inside the upper tube 30 is an upper square torsion bar 38 and inside the lower tube 32 is a lower torsion bar 40. The torsion bars 38, 40 can be seen in the cross section of FIG. 3. Surrounding the torsion bars 38, 40 are resilient cords 42. The resilient cord 42 supports the torsion bar 38, 40 and centers it about its corresponding axis 34, 36. As shown, the torsion bars 38, 40 are angled with respect to their corresponding tube 30, 32 with the flats facing corners of the tube. This creates a substantially triangular shaped cavity that receives the resilient cords 42. They fit in the corners of the tubes 30, 32 and overlay the flat surfaces of the torsion bars 38, 40. This setup of a torsion bar inside a torsion tube is commonly known in the suspension and spring art.

Attached to ends of the upper torsion bar 38 are upper torsion arms 44. The upper torsion arms 44 are not affixed to the upper torsion tube 30 and rotate with the upper torsion bar 38. The upper torsion arms 44 are affixed to the upper torsion bar 38 sufficiently close to the ends of the upper torsion tube 30 to prevent excessive axial movement of the upper torsion bar 38 and upper torsion arms 44 along the upper central axis 34. At the end of the upper torsion arm 44 is an upper pivot point 46. Both pivot points 46 align to form an upper pivot axis 48. The upper pivot axis 48 is parallel to and offset from the upper central axis 34.

Correspondingly, attached to ends of the lower torsion bar 40 are lower torsion arms 50. The lower torsion arms 50 are not affixed to the lower torsion tube 32 and rotate with the lower torsion bar 40 as shown in FIG. 1. The lower torsion arms 50 are affixed to the lower torsion bar 40 sufficiently close to the ends of the lower torsion tube 32 to prevent excessive axial movement of the lower torsion bar 40 and lower torsion arms 50 along the lower central axis 36. At the end of the lower torsion arm 50 is a lower pivot point 52. Both lower pivot points 52 align to form a lower pivot axis 54. The lower pivot axis 54 is parallel to and offset from the lower central axis 36.

The receiver portion 14 has an upper pivot tube 60 and a lower pivot tube 62 that are spaced similarly to the pivot points 46, 52. The receiver portion 14, as shown in all FIGS. has a series of receivers 64-70. Each receiver 64-70 is made from a rectangular tube and is sized to receive a slide-in ball hitch or similar device and has transverse holes 66, 72 that are adapted to receive a pin to affix the slide-in ball hitch (not shown). As shown in FIG. 4, the uppermost 64 and lowermost 70 receivers have an extra transverse hole 72 that allows the separate towing hook or ball to be affixed to the receiver portion 14 at a second position. The receiver portion 14 has sides 74, 76 that reinforce and align the receivers 64-70. The pivot tubes 60, 62 extend through the sides 74, 76 and the uppermost 64 and lowermost 70 receivers. The pivot tubes 60, 62 are long enough to fit between the pivot arms 44, 50 without allowing excessive axial movement along the pivot axes 48, 54.

Due to the resilient nature of the cords 42, the torsion bars 38, 40 are held in a neutral or resting position (as shown in

all FIGS) where all of the cords **42** equally apply pressure to the outside flat surfaces of the torsion bar **38, 40**. When a load is applied and the torsion bar **38, 40** begins to rotate, the torsion bar **38, 40** is urged toward the neutral position by the cords **42**.

As weight is added to the receiver portion **14** (by the separate towing hook or ball), the entire receiver portion **14** moves down, causing the pivot arms **44, 50** to rotate. The cords **42** become distorted by the flat surfaces of the torsion bars **38, 40** as they rotate. The resiliency of the cord **42** resists the distortion. The more the torsion bar **38, 40** rotates, the more the cords **42** resist. The spacing of the pivot arms **44, 50**, pivot points **46, 52** and central axis **34, 36** causes the receiver portion **14** to move substantially vertical with minimal to no rotation or angular change with respect to the draw bar **18**.

An optional displacement or load indicator **80** can be implemented to show the user the amount of tongue weight or displacement of the receiver portion **14** with respect to the fixed portion **12**. As shown in FIG. **5**, the indicator **80** has a needle **82** that is fixed to one of the pivot arms **44**. As the weight on the receiver portion **14** increases, the displacement indicator **80** shows the user how much load is present. The upper torsion tube **30** has a reference line or feature **84**. As the pivot arm **44** rotates, the needle **82** moves with respect to the feature **84**, showing the user the amount of load on the hitch receiver **10**. As shown in FIG. **5**, a fastener **86** holds the needle **82** and allows adjustment of the needle **82** to set a desired number or zero reference.

It is understood that while certain aspects of the disclosed subject matter have been shown and described, the disclosed subject matter is not limited thereto and encompasses various other embodiments and aspects. No specific limitation with respect to the specific embodiments disclosed herein is intended or should be inferred. Modifications may be made to the disclosed subject matter as set forth in the following claims.

What is claimed is:

1. A torsion hitch adapted to be affixed between a towing vehicle and a trailer, said towing vehicle having a vehicle-mounted receiver, said torsion hitch comprising:

a draw bar having a draw bar axis and affixed to a torsion housing, said draw bar being an elongate member adapted to be received by said vehicle-mounted receiver and having a transverse hole adapted to receive a pin to affix said draw bar to said vehicle-mounted receiver, said torsion housing having an upper torsion tube with an upper central axis and a lower torsion tube with a lower central axis, said upper and lower central axes being substantially perpendicular to said draw bar axis, said upper and lower central axis being substantially parallel, said draw bar axis passing between said upper and lower central axes;

an upper torsion arm affixed to a terminal end of an upper torsion bar being held within said upper torsion tube to resist rotation with respect to said upper torsion tube, said upper torsion arm having an upper pivot point spaced from said upper torsion bar, a lower torsion arm affixed to a terminal end of a lower torsion bar being held within said lower torsion tube to resist rotation with respect to said lower torsion tube, said lower torsion arm having a lower pivot point spaced from said lower torsion bar;

a receiver assembly having an upper pivot point with a central axis and a lower pivot point with a central axis, said receiver assembly having at least two receivers affixed to said receiver assembly and adapted to receive

an accessory draw bar, each receiver containing a transverse hole adapted to affix said accessory draw bar to said receiver;

said pivot points of said upper and lower arms rotatably affixed to said pivot points of said receiver assembly; said upper and lower torsion arms rotatable between an unloaded position and a loaded position and being biased toward said unloaded position; said receivers of said receiver assembly remaining substantially parallel to said draw bar when said torsion arms move from said unloaded position to said loaded position; and

a load indicator affixed to said upper torsion arm to measure an angle of said torsion arm with respect to said torsion housing.

2. The torsion hitch of claim **1**, said receiver assembly having a second transverse hole extending through one of said receivers to affix said accessory draw bar.

3. The torsion hitch of claim **2**, said load indicator adjustably affixed to said torsion housing, said load indicator having a pointer overlaying a portion of said upper arm.

4. The torsion hitch of claim **2**, said load indicator adjustably affixed to one of said torsion arms, said load indicator having a pointer adapted to indicate said angle of said arm with respect to said housing.

5. The torsion hitch of claim **2**, said receiver assembly having four vertically stacked receivers, one of said receivers being an uppermost, one of said receivers being lowest, two of said receivers located between said uppermost and said lowest.

6. The torsion hitch of claim **5**, said uppermost receiver intersecting an upper pivot axis aligned with said pivot points of said upper arms, said lowest receiver intersecting a lower pivot axis aligned with said pivot points of said lower pivot arms.

7. A torsion hitch adapted to be affixed between a towing vehicle and a trailer, said towing vehicle having a vehicle-mounted receiver, said torsion hitch comprising:

a draw bar having a draw bar axis and affixed to a torsion housing, said draw bar being an elongate member adapted to be received by said vehicle-mounted receiver and having a transverse hole adapted to receive a pin to affix said draw bar to said vehicle-mounted receiver, said torsion housing having an upper torsion tube with an upper central axis and a lower torsion tube with a lower central axis, said upper and lower central axes being substantially perpendicular to said draw bar axis, said upper and lower central axis being substantially parallel, said draw bar axis passing between said upper and lower central axes;

an upper torsion arm affixed to a terminal end of an upper torsion bar being held within said upper torsion tube to resist rotation with respect to said upper torsion tube, said upper torsion arm having an upper pivot point spaced from said upper torsion bar, a lower torsion arm affixed to a terminal end of a lower torsion bar being held within said lower torsion tube to resist rotation with respect to said lower torsion tube, said lower torsion arm having a lower pivot point spaced from said lower torsion bar;

a receiver assembly having an upper pivot point with a central axis and a lower pivot point with a central axis, said receiver assembly having at least two receivers affixed to said receiver assembly and adapted to receive an accessory draw bar, each receiver containing a transverse hole adapted to affix said accessory draw bar to said receiver;

5

a resilient cord being held within one of said torsion housings and directly contacting an inside surface of said torsion housing and an outside surface of said torsion bar;

said pivot points of said upper and lower arms rotatably affixed to said pivot points of said receiver assembly; and

said upper and lower torsion arms rotatable between an unloaded position and a loaded position and being biased toward said unloaded position; said receivers of said receiver assembly remaining substantially parallel to said draw bar when said torsion arms move from said unloaded position to said loaded position.

8. The torsion hitch of claim 7, a load indicator adjustably affixed to said torsion housing and adjacent to one of said arms, said load indicator having a pointer indicating an angular position of said arm with respect to said housing.

9. The torsion hitch of claim 7, said receiver assembly having a second transverse hole extending through one of said receivers to affix said accessory draw bar.

10. The torsion hitch of claim 9, said receiver assembly having four vertically stacked receivers, one of said receivers being an uppermost, one of said receivers being lowest, two of said receivers located between said uppermost and said lowest.

11. The torsion hitch of claim 10, said load indicator adjustably affixed to one of said torsion arms, said load indicator having a pointer adapted to indicate said angle of said arm with respect to said housing.

12. A torsion hitch adapted to be affixed between a towing vehicle and a trailer, said towing vehicle having a vehicle-mounted receiver, said torsion hitch comprising:

a draw bar having a draw bar axis and affixed to a torsion housing, said draw bar being an elongate member adapted to be received by said vehicle-mounted receiver and having a transverse hole adapted to receive a pin to affix said draw bar to said vehicle-mounted receiver, said torsion housing having an upper torsion tube with an upper central axis and a lower torsion tube with a lower central axis, said upper and lower central axes being substantially perpendicular to said draw bar axis, said upper and lower central axis being substantially parallel, said draw bar axis passing between said upper and lower central axes;

an upper torsion arm affixed to a terminal end of an upper torsion bar being held within said upper torsion tube to resist rotation with respect to said upper torsion tube, said upper torsion arm having an upper pivot point

6

spaced from said upper torsion bar, a lower torsion arm affixed to a terminal end of a lower torsion bar being held within said lower torsion tube to resist rotation with respect to said lower torsion tube, said lower torsion arm having a lower pivot point spaced from said lower torsion bar;

a receiver assembly having an upper pivot point with a central axis and a lower pivot point with a central axis, said receiver assembly having at least two receivers affixed to said receiver assembly and adapted to receive an accessory draw bar, each receiver containing a transverse hole adapted to affix said accessory draw bar to said receiver;

a resilient cord being held within one of said torsion housings and directly contacting an inside surface of said torsion housing and an outside surface of said torsion bar; and

said pivot points of said upper and lower arms rotatably affixed to said pivot points of said receiver assembly.

13. The torsion hitch of claim 12, said upper and lower torsion arms rotatable between an unloaded position and a loaded position and being biased toward said unloaded position; said receivers of said receiver assembly remaining substantially parallel to said draw bar when said torsion arms move from said unloaded position to said loaded position.

14. The torsion hitch of claim 13, said torsion member being a torsion axle having a torsion bar affixed to one of said torsion arms and a torsion tube affixed to said receiver assembly, said torsion axle urging said first and second torsion arms toward said unloaded position.

15. The torsion hitch of claim 14, said receiver assembly having a second transverse hole extending through one of said receivers to affix said accessory draw bar.

16. The torsion hitch of claim 12, said receiver assembly having four vertically stacked receivers, one of said receivers being an uppermost, one of said receivers being lowest, two of said receivers located between said uppermost and said lowest.

17. The torsion hitch of claim 16, said load indicator adjustably affixed to one of said torsion arms, said load indicator having a pointer adapted to indicate said angle of said arm with respect to said housing.

18. The torsion hitch of claim 12, a load indicator adjustably affixed to said torsion housing and adjacent to one of said arms, said load indicator having a pointer indicating an angular position of said arm with respect to said housing.

* * * * *

(12) **United States Patent**
Borkholder

(10) **Patent No.:** **US 9,868,327 B1**
(45) **Date of Patent:** **Jan. 16, 2018**

- (54) **TORSION HITCH RECEIVER**
(71) Applicant: **Carl Borkholder**, Bremen, IN (US)
(72) Inventor: **Carl Borkholder**, Bremen, IN (US)
(*) Notice: Subject to any disclaimer, the term of this patent is extended or adjusted under 35 U.S.C. 154(b) by 0 days.

6,957,825 B2 *	10/2005	Peters	B60D 1/07
				280/483
7,775,544 B2 *	8/2010	Bouwkamp	B60D 1/143
				280/483
9,505,281 B1 *	11/2016	Borkholder	B60D 1/248
2003/0178811 A1 *	9/2003	Buckner	B60D 1/50
				280/483
2005/0263984 A1 *	12/2005	Gurtler	B60D 1/485
				280/489

- (21) Appl. No.: **15/286,111**
(22) Filed: **Oct. 5, 2016**

* cited by examiner

Primary Examiner — Tony H Winner
Assistant Examiner — Michael R Stabley
(74) *Attorney, Agent, or Firm* — Botkin & Hall, LLP

- (51) **Int. Cl.**
B60D 1/24 (2006.01)
B60D 1/50 (2006.01)
B60D 1/06 (2006.01)
(52) **U.S. Cl.**
CPC **B60D 1/24** (2013.01); **B60D 1/065** (2013.01); **B60D 1/50** (2013.01); **B60D 1/248** (2013.01)
(58) **Field of Classification Search**
CPC B60D 1/24; B60D 1/50; B60D 1/065
See application file for complete search history.

(57) **ABSTRACT**

A torsion hitch receiver is provided having a frame that has a portion that mounts to a vehicle. The frame includes an upper torsion tube that carries an upper torsion bar. Attached to the upper torsion tube is a torsion housing that affixes a lower torsion tube. The upper torsion bar has an upper torsion arm that rotates with the upper torsion bar, and a lower torsion bar, carried within the lower torsion tube, the lower torsion bar has lower torsion arms. Both upper and lower torsion arms attach to a receiver housing that can receive a draw bar. As weight is applied to the receiver housing, the torsion bars allow rotation. As the torsion bars rotate, the receiver housing moves up and down.

- (56) **References Cited**
U.S. PATENT DOCUMENTS
4,792,154 A * 12/1988 Kerst B60D 1/50
280/489
6,698,785 B2 * 3/2004 Peters B60D 1/07
280/489

14 Claims, 7 Drawing Sheets

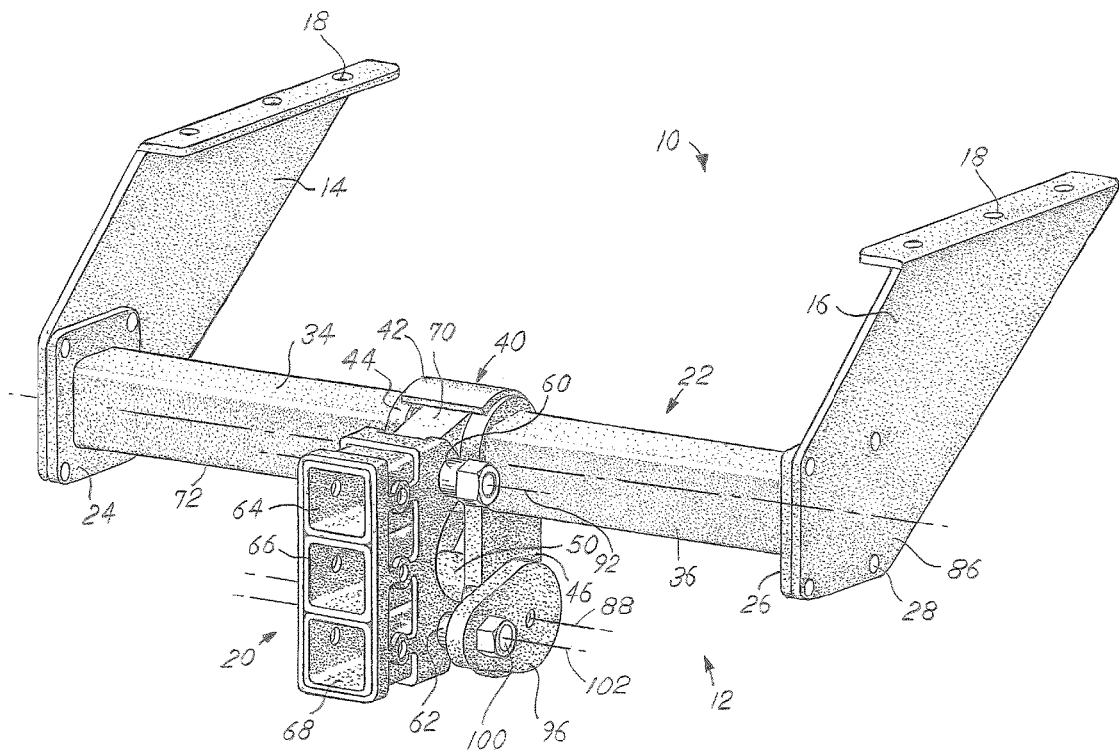

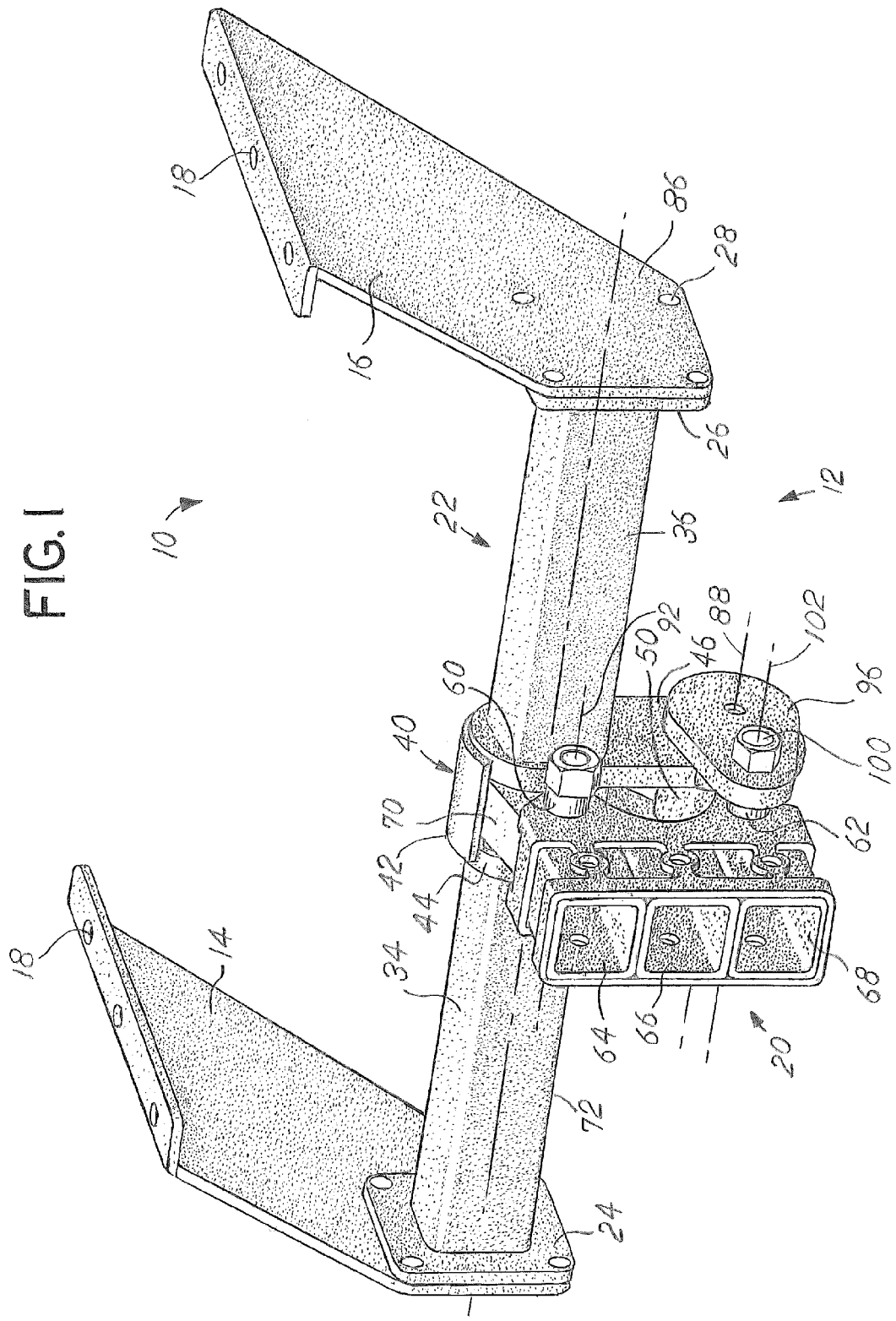
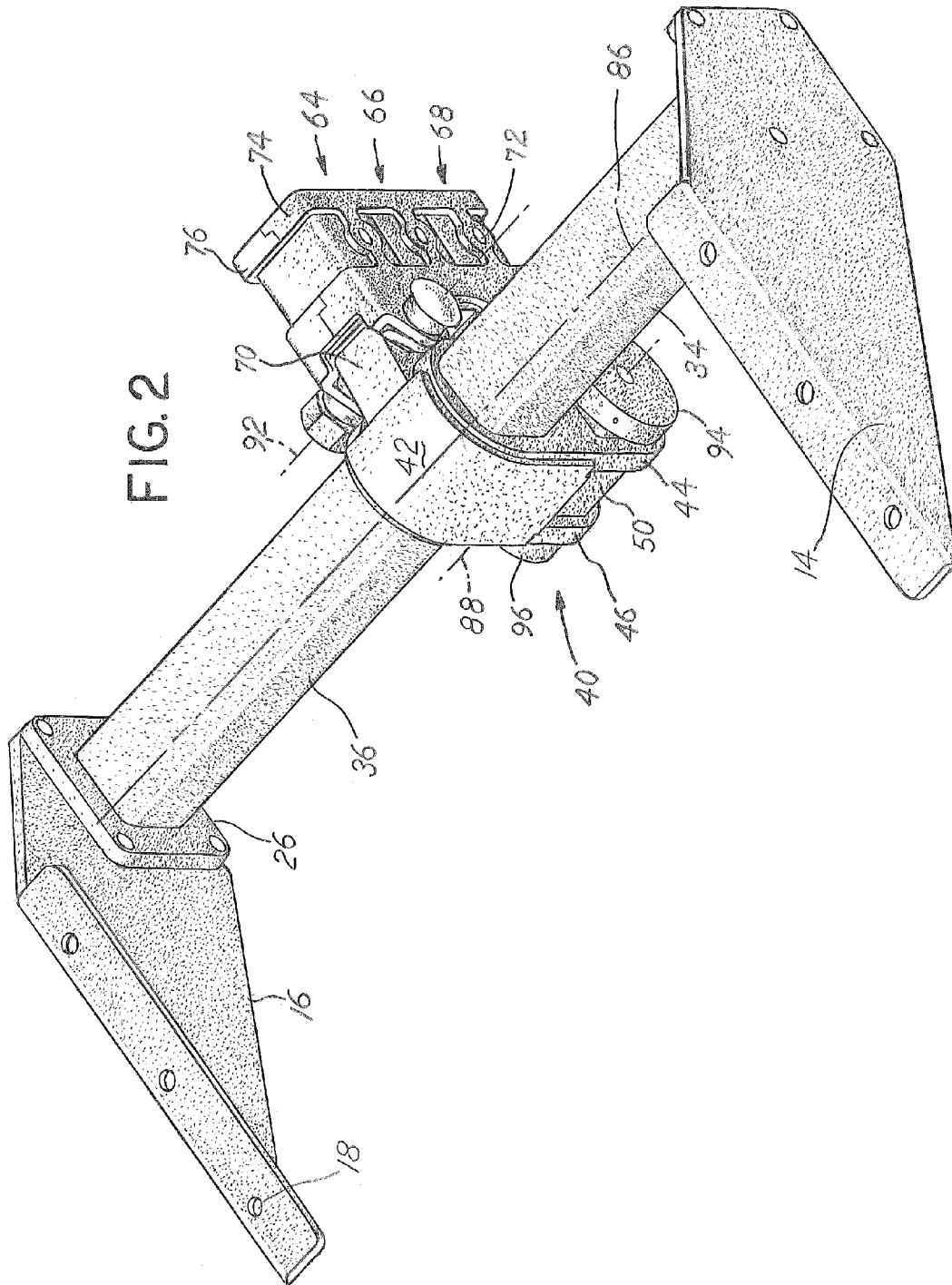

FIG. 1



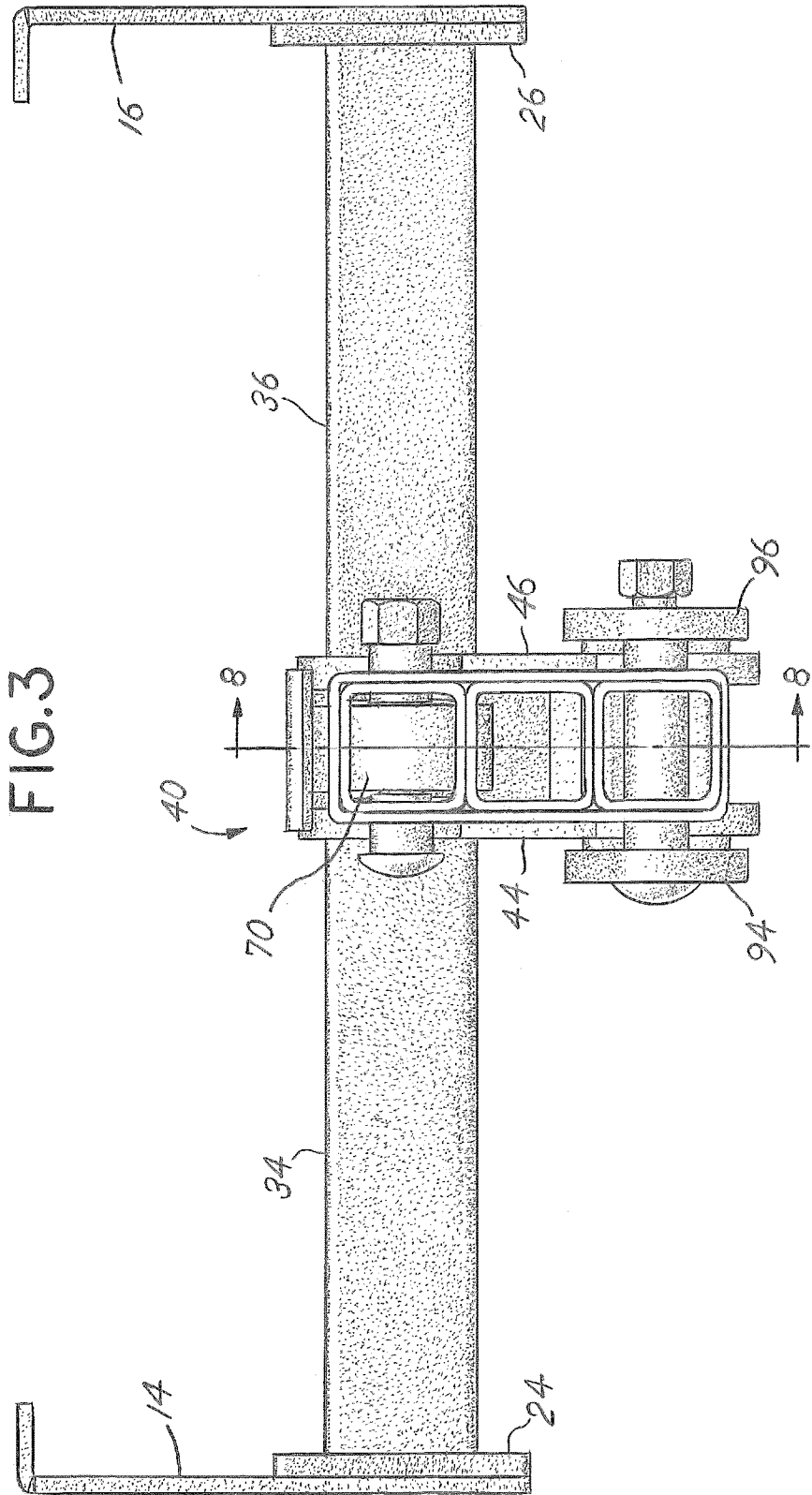
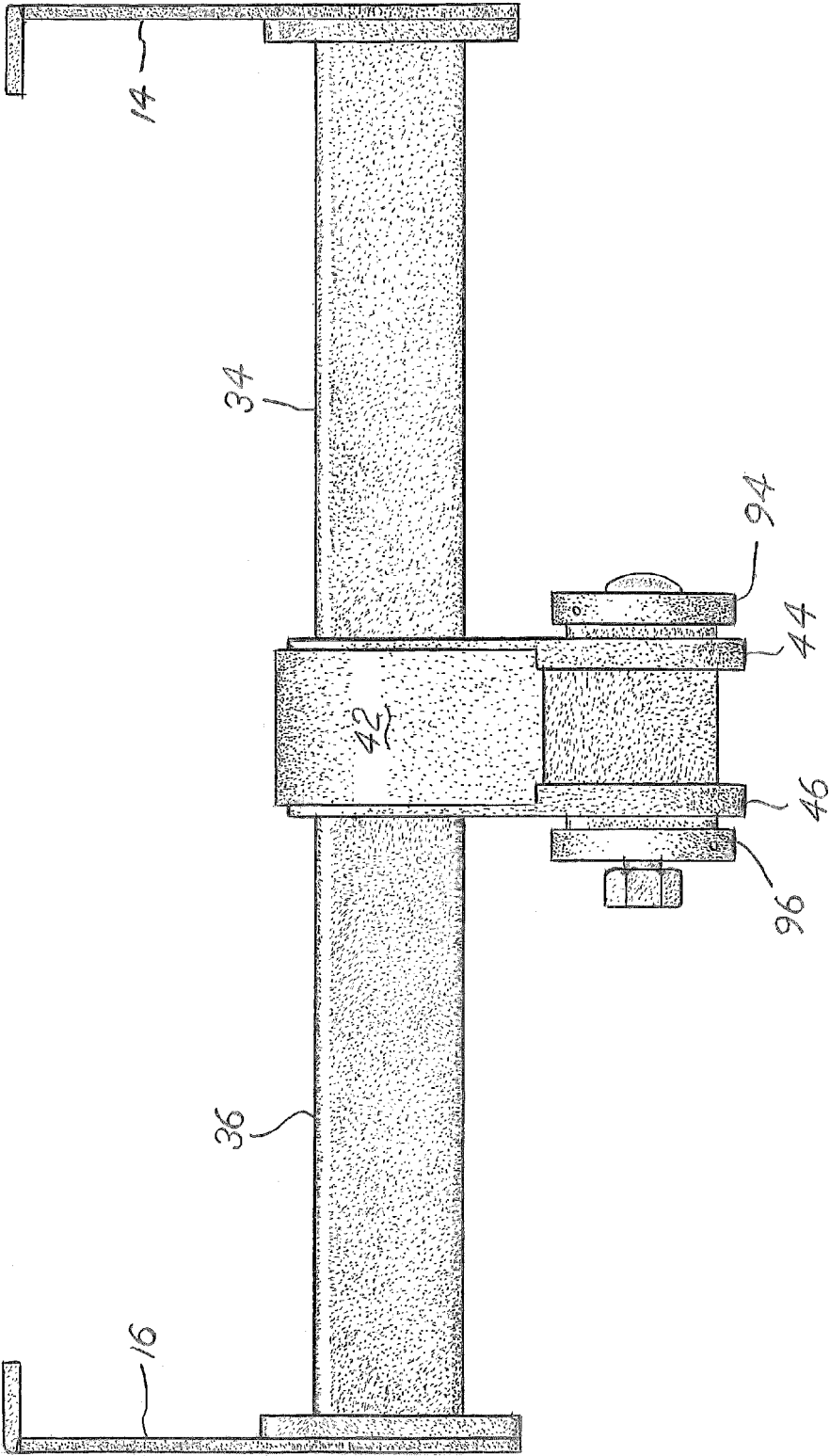

FIG. 4



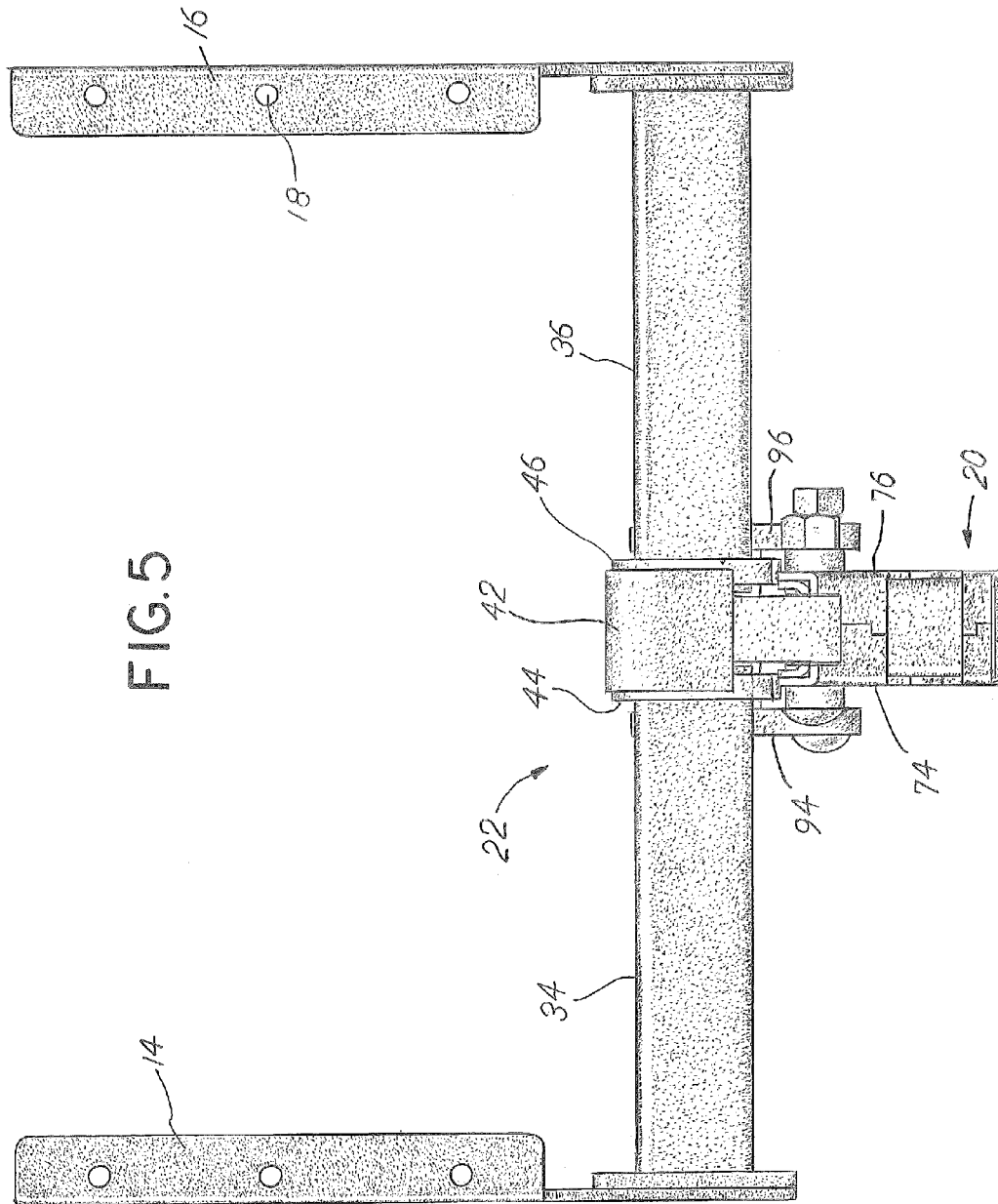

FIG. 5

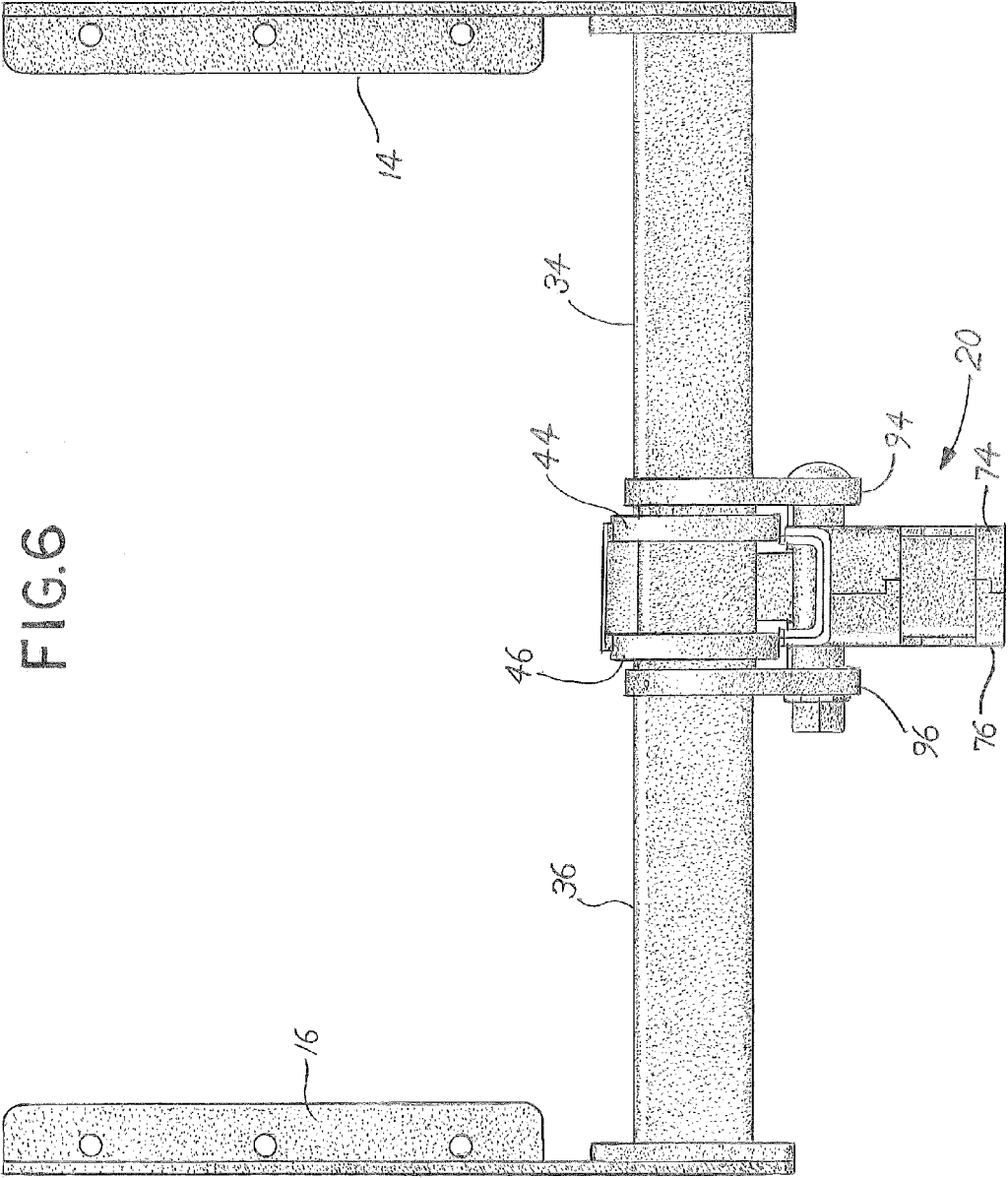
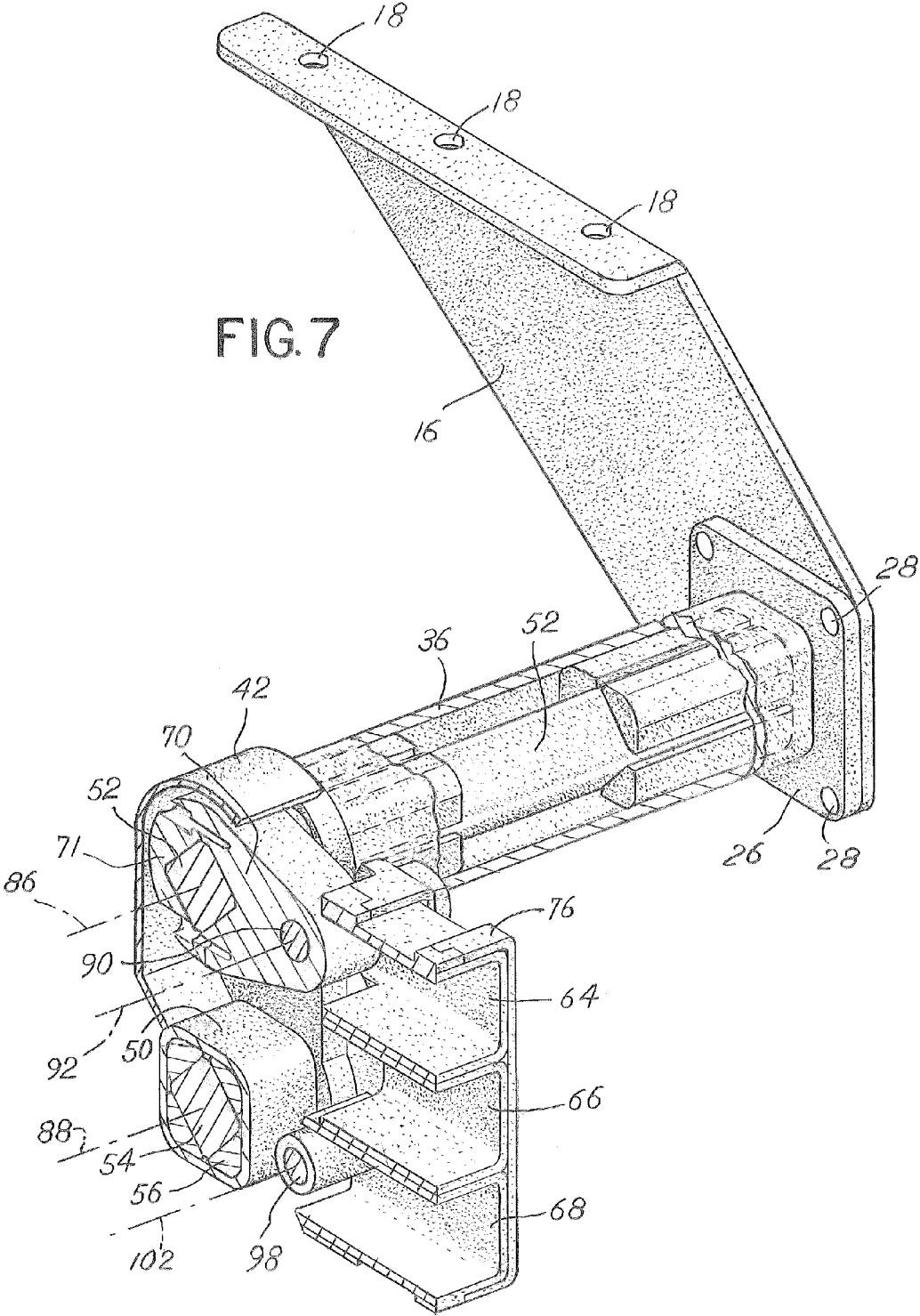

FIG.6



1

TORSION HITCH RECEIVER

BACKGROUND OF THE INVENTION

This present disclosure relates to vehicle mounted hitch receivers and the attachment between a trailer and a towing vehicle. Commonly, when being towed by a vehicle, the trailer is subject to transient forces as the towing vehicle pulls the trailer over various terrain or when loads are moved or placed on the trailer. Trailers have a tongue weight that is borne by the towing vehicle. Some tongue weight is necessary but it is desirable to limit the amount transmitted to the towing vehicle. The transient forces on the trailer can translate to transient tongue forces transmitted to the towing vehicle, at the very least, can be unsettling to the driver. In an extreme situation, the transient tongue forces can create a dangerous loss of control. One option is to use a receiver adapter that can be located between the trailer and the towing vehicle, but the adapter increases the distance between the vehicle and the trailer. An improved receiver is needed.

SUMMARY OF THE INVENTION

The present disclosure describes a vehicle mounted torsion hitch receiver that will permanently attach to a towing vehicle and absorb transient tongue loading either caused by the towing vehicle or the trailer. By implementing a torsion device, the hitch receiver allows for limited relative vertical motion between the towing vehicle and the trailer tongue. The hitch receiver has multiple receiver holes that are vertically stacked to give the user several height options of where to connect up a ball. The vertical stacking is frequently necessary when the trailer tongue height varies from trailer to trailer, and also the height of the receiver on different towing vehicles is different. An optional indicator measures the displacement between a loaded position and an unloaded position to allow the user to monitor tongue loading.

BRIEF DESCRIPTION OF THE DRAWINGS

A preferred embodiment of this invention has been chosen wherein:

- FIG. 1 is a front isometric view of the hitch receiver;
- FIG. 2 is a rear isometric view of the hitch receiver;
- FIG. 3 is a front view of the hitch receiver;
- FIG. 4 is a rear view of the hitch receiver;
- FIG. 5 is a top view of the hitch receiver;
- FIG. 6 is a bottom view of the hitch receiver; and
- FIG. 7 is a section view 8-8 of the hitch receiver in FIG. 3.

DESCRIPTION OF THE PREFERRED EMBODIMENT

A vehicle mounted hitch receiver 10 is shown in FIGS. 1-7 that has a frame 12 with a first mounting portion 14 and a second mounting portion 16. The mounting portions 14, 16 are designed to affix the receiver 10 to a structurally sound part of a vehicle (not shown), commonly a frame or reinforced area of a vehicle's body. Holes 18 are drilled or stamped into the mounting portions 14, 16 to allow the attachment. Typically, the hitch receiver 10 is permanently affixed to the vehicle but it is contemplated the receiver 10 is removable. The location, size, and shape of the holes 18 and mounting portions 14, 16 will vary from vehicle to

2

vehicle. Some embodiments can further include tapped holes in addition to or where holes 18 are currently shown. The mounting portions 14, 16 are shown as a formed stamping, but other shapes and materials are contemplated. A receiver portion 20 is designed to receive a draw bar with a towing hitch ball (not shown). The draw bar is then affixed to the receiver portion 20 through a pin or other locking feature. Locking draw bars to hitch receivers is well-known in the art.

Located between the mounting portions 14, 16 is a center section 22 that is attached to the mounting portions 14, 16 by flanges 24, 26. The flanges 24, 26 attach to their respective mounting portions 14, 16 through fasteners 28 or welding. A first upper torsion tube 34 is affixed to flange 24 and a second upper torsion tube 36 is affixed to flange 26. The torsion tubes 34, 36 are coaxial and mechanically connected by a torsion housing 40. The center section 22 shows torsion tubes 34, 36 extending completely between the mounting portions 14, 16, but it is contemplated that the torsion tubes 34, 36 only extends partially. For example, some vehicles have obstructions that are not movable, such as exhaust pipes, bumper features, or other frame protrusions that prevent a straight torsion tube from extending across. In this event, the mounting portions 14, 16 may further contain a structural piece that connects its respective torsion tube 34, 36. The torsion housing 40 is made up of a curved back 42, a first side 44, and a second side 46, shown in FIGS. 4-6. The back 42, first side 44, and second side 46 are all mechanically fixed together, typically through welding or fasteners. First side 44 is affixed to torsion tube 34 and second side 46 is affixed to torsion tube 36. Also located in the torsion housing 40 is a lower torsion tube 50. The lower torsion tube 50 is affixed to side 44 at a terminal end and affixed to side 46 at the opposite terminal end.

The torsion housing 40 is an assembly of a series of parts made from flat or bent sheet metal that is welded or affixed together to the torsion tubes 34, 36 to form a single structural component. In addition to the bent and flat sheet metal is a lower torsion tube 50. Each torsion tube 34, 36, 50 is mostly square and has a corresponding central axis 86, 88. A section view of the torsion housing is shown in FIG. 7. The central axis 86 of the upper tubes 34, 36 is parallel to the central axis 88 of the lower tube 32. The central axes 86, 88 do not have to be exactly parallel, only sufficiently parallel for the mechanism to move without binding. The torsion housing 40 and upper tubes 34, 36 are fixed with respect to the mounting portions 14, 16.

Residing inside the upper tubes 34, 36 is an upper torsion bar 52 and inside the lower tube 50 is a lower torsion bar 54. As shown, the upper torsion bar 52 extends outwardly to the outer ends of the upper torsion tubes 34, 36. The lower torsion bar 54 extends beyond the ends of the lower torsion tube 50. The torsion bars 52, 54 can be seen in the cross section of FIG. 7. Surrounding the torsion bars 52, 54 are resilient cords 56. The resilient cord 56 supports the torsion bars 52, 54 and centers them about their corresponding axis 86, 88. As shown, the torsion bars 52, 54 are angled with respect to their corresponding tube 34, 36, 50 with the flats facing corners of the tube. This creates substantially triangular shaped cavities that receive the resilient cords 56. They fit in the corners of the tubes and overlay the flat surfaces of the torsion bars 52, 54. A torsion bar located inside a torsion tube and surrounded by resilient cords is commonly known in the suspension and spring art.

The upper torsion arm 70 is fixed to and rotates with the upper torsion bar 52. The upper torsion arm 70 is affixed in the middle and is wide enough to be close to both sides 44,

3

46 to prevent excessive axial movement of the upper torsion bar 52 and upper torsion arm 70 along the upper central axis 86. At the end of the upper torsion arm 70 is an upper pivot point 90. The upper pivot point 90 forms an upper pivot axis 92. The upper pivot axis 92 is parallel to and offset from the upper central axis 86, shown in FIG. 1. The axes 92, 86 do not have to be exactly parallel, only sufficiently parallel for the mechanism to move without binding. As shown in FIG. 7, the upper torsion arm 70 has a rear piece 71 that attaches to the upper torsion arm 70 and the two affix around the upper torsion bar 52.

Attached to ends of the lower torsion bar 54 are lower torsion arms 94, 96. The lower torsion arms 94, 96 overlay a portion of the sides 44, 46 and rotate with the lower torsion bar 54 as shown in FIG. 1. The lower torsion arms 94, 96 are affixed to the terminal ends of the lower torsion bar 54 sufficiently close to the sides 44, 46 to prevent excessive axial movement of the lower torsion bar 54 and lower torsion arms 94, 96 along the lower central axis 88. At the end of each lower torsion arm 94, 96 is a corresponding lower pivot point 98, 100. Both lower pivot points 98, 100 align to form a lower pivot axis 102. The lower pivot axis 102 is parallel to and offset from the lower central axis 88. The axes 88, 102 do not have to be exactly parallel, only sufficiently parallel for the mechanism to move without binding.

The receiver portion 20 has an upper pivot tube 60 and a lower pivot tube 62 that are spaced similarly to the pivot points. The receiver portion 20, as shown in all FIGS. shows a series of receivers 64-68 for example. Each receiver 64-68 is made from a rectangular tube, visible in FIG. 3, and is sized to receive a slide-in ball hitch or similar device and has transverse holes 72 that are adapted to receive a pin to affix the slide-in ball hitch (not shown). While three receivers are shown, it is contemplated that a single receiver or several receivers are affixed to the receiver portion 20. The receiver portion 20 has sides 74, 76 that reinforce and align the receivers 64-68. The pivot tubes 60, 62 extend through the sides 74, 76 and the uppermost 64 and lowermost 68 receivers. The pivot tubes 60, 62 are long enough to fit between the pivot arms without allowing excessive axial movement along the pivot axes 92, 102.

Due to the resilient nature of the cords 56, the torsion bars 52, 54 are held in a neutral or resting position (as shown in all FIGS) where all of the cords 56 equally apply pressure to the outside flat surfaces of the torsion bar 52, 54. The cords 56 are shown in FIG. 7. When a load is applied and the torsion bar 52, 54 begins to rotate, the torsion bar 52, 54 is urged toward the neutral position by the cords 56.

As weight is added to the receiver portion 20 (by the separate towing hook or ball), the entire receiver portion 20 moves down and the pivot arms rotate. The cords 56 become distorted by the flat surfaces of the torsion bars 52, 54 as they rotate. The resiliency of the cord 56 resists the distortion. The more the torsion bar rotates, the more the cords resist. The spacing of the pivot arms, pivot points 90, 98, 100 and central axis 86, 88 causes the receiver portion 20 to move vertically with minimal to no rotation or angular change with respect to the mounting portions 14, 16.

An optional displacement or load indicator (not shown) can be implemented to show the user the amount of tongue weight or displacement of the receiver portion 20 with respect to the fixed portion 12. The indicator has a needle that is fixed to one of the pivot arms. As the weight on the receiver portion 20 increases, the displacement indicator shows the user how much load is present. The torsion housing 40 may have a reference line or feature. As the pivot

4

arm rotates, the needle moves with respect to the feature, showing the user the amount of load on the hitch receiver 10. A fastener holds the needle and allows adjustment of the needle to set a desired number or zero reference.

It is understood that while certain aspects of the disclosed subject matter have been shown and described, the disclosed subject matter is not limited thereto and encompasses various other embodiments and aspects. No specific limitation with respect to the specific embodiments disclosed herein is intended or should be inferred. Modifications may be made to the disclosed subject matter as set forth in the following claims.

What is claimed is:

1. A torsion hitch receiver adapted to be permanently affixed to a towing vehicle, said torsion hitch receiver adapted to receive an accessory draw bar, said receiver comprising:

a frame having a first and second vehicle attaching portion adapted to be affixed to a portion of said towing vehicle, said frame having a center portion affixed to and located between said vehicle attaching portions, said center portion having a first and second upper torsion tube carrying an upper torsion bar on an upper central axis, said first upper torsion tube affixed to said first vehicle attaching portion, said second upper torsion tube affixed to said second vehicle attaching portion, said upper torsion bar resisting rotation with respect to said upper torsion tubes;

said center portion having a torsion housing affixed to and located between said first and second upper torsion tubes, said torsion housing having a lower torsion tube with a lower central axis, said torsion housing having a first side and a second side, said lower torsion tube being spaced from said first and second upper torsion tubes, said upper and lower central axes being substantially parallel, said upper torsion bar extending through said torsion housing;

an upper torsion arm affixed to said upper torsion bar and extending outwardly from said torsion housing, a portion of said upper torsion bar located between said first side and said second side of said torsion housing, said upper torsion arm having an upper pivot point spaced from said upper torsion bar;

lower torsion arms affixed to terminal ends of a lower torsion bar, said lower torsion bar being held within said lower torsion tube to resist rotation with respect to said lower torsion tube, one of said lower torsion arms adjacent said first side of said torsion housing, the other of said lower torsion arms adjacent said second side of said torsion housing, each said torsion arm having a lower pivot point spaced from said lower torsion bar; a receiver assembly connected to and movable with respect to said torsion housing and having an upper pivot point with a central axis and a lower pivot point with a central axis, said receiver assembly having at least two receivers affixed to said receiver assembly, each said receivers adapted to receive and affix said accessory draw bar;

said pivot points of said upper and lower arms rotatably affixed to said pivot points of said receiver assembly; and

said upper and lower torsion arms rotatable between an unloaded position and a loaded position and being biased toward said unloaded position, said receivers of said receiver assembly remaining substantially parallel to said draw bar when said torsion arms move from said unloaded position to said loaded position.

5

2. The torsion hitch receiver of claim 1, wherein said first and second upper torsion tubes are directly affixed to said first and second vehicle attaching portions.

3. The torsion hitch receiver of claim 1, wherein a curved back affixes said first side to said second side of said torsion housing.

4. The torsion hitch receiver of claim 1, wherein said upper pivot point spacing from said upper torsion bar is equal to said lower pivot point spacing from said lower torsion bar.

5. A torsion hitch receiver adapted to be affixed to a towing vehicle, said torsion hitch receiver adapted to receive an accessory draw bar, said receiver comprising:

a frame having a first and second vehicle attaching portion adapted to be affixed to a portion of said towing vehicle, said frame having an upper torsion tube affixed to said vehicle attaching portions, said upper torsion tube carrying an upper torsion bar on an upper central axis, said upper torsion bar resisting rotation with respect to said upper torsion tube;

a torsion housing affixed to said upper torsion tube and having a lower torsion tube with a lower central axis, said torsion housing having a first side and a second side, said lower torsion tube affixed to said torsion housing and being spaced from said upper torsion tube, said upper and lower central axes being substantially parallel;

an upper torsion arm affixed to said upper torsion bar and extending outwardly from said torsion housing, a portion of said upper torsion bar located between said first side and said second side of said torsion housing, said upper torsion arm having an upper pivot point spaced from said upper torsion bar;

lower torsion arms affixed to terminal ends of a lower torsion bar, said lower torsion bar being held within said lower torsion tube to resist rotation with respect to said lower torsion tube, one of said lower torsion arms adjacent said first side of said torsion housing, the other of said lower torsion arms adjacent said second side of said torsion housing, each said torsion arm having a lower pivot point spaced from said lower torsion bar;

a receiver assembly connected to and movable with respect to said torsion housing and having an upper pivot point with a central axis and a lower pivot point with a central axis, said receiver assembly adapted to receive and affix said accessory draw bar;

said pivot points of said upper and lower arms rotatably affixed to said pivot points of said receiver assembly; and

said upper and lower torsion arms rotatable between an unloaded position and a loaded position and being biased toward said unloaded position, said receiver of said receiver assembly remaining substantially parallel to said draw bar when said torsion arms move from said unloaded position to said loaded position.

6. The torsion hitch receiver of claim 5, wherein said upper torsion tube is directly affixed to said first and second vehicle attaching portions.

7. The torsion hitch receiver of claim 5, wherein a curved back affixes said first side to said second side of said torsion housing.

6

8. The torsion hitch receiver of claim 5, wherein said upper pivot point spacing from said upper torsion bar is equal to said lower pivot point spacing from said lower torsion bar.

9. The torsion hitch receiver of claim 5, said upper torsion tube separated into a first and second torsion tube by said torsion housing, said upper torsion bar extending through said torsion housing.

10. A torsion hitch receiver adapted to be affixed to a towing vehicle, said torsion hitch receiver adapted to receive an accessory draw bar, said receiver comprising:

an upper torsion tube carrying an upper torsion bar on an upper central axis, said upper torsion bar resisting rotation with respect to said upper torsion tube;

a torsion housing affixed to said upper torsion tube and having a lower torsion tube with a lower central axis, said lower torsion tube affixed to said torsion housing and being spaced from said upper torsion tube, said upper and lower central axes being substantially parallel;

an upper torsion arm affixed to said upper torsion bar, a portion of said upper torsion arm located inside said torsion housing, said upper torsion arm having an upper pivot point spaced from said upper torsion bar;

lower torsion arms affixed to terminal ends of a lower torsion bar, said lower torsion bar being held within said lower torsion tube to resist rotation with respect to said lower torsion tube, said lower torsion arms located outside said torsion housing, each said torsion arm having a lower pivot point spaced from said lower torsion bar;

a receiver assembly connected to and movable with respect to said torsion housing and having an upper pivot point with a central axis and a lower pivot point with a central axis, said receiver assembly adapted to receive and affix said accessory draw bar;

said pivot points of said upper and lower arms rotatably affixed to said pivot points of said receiver assembly; and

said upper and lower torsion arms rotatable between an unloaded position and a loaded position and being biased toward said unloaded position, said receiver of said receiver assembly remaining substantially parallel to said draw bar when said torsion arms move from said unloaded position to said loaded position.

11. The torsion hitch receiver of claim 10, said receiver further comprising first and second vehicle attaching portions, said upper torsion tube is directly affixed to said first and second vehicle attaching portions.

12. The torsion hitch receiver of claim 10, wherein said torsion housing having a curved back that affixes a first side to a second side of said torsion housing.

13. The torsion hitch receiver of claim 10, wherein said upper pivot point spacing from said upper torsion bar is equal to said lower pivot point spacing from said lower torsion bar.

14. The torsion hitch receiver of claim 10, said upper torsion tube separated into a first and second torsion tube by said torsion housing, said upper torsion bar extending through said torsion housing.

(12) **United States Design Patent**
Borkholder

(10) **Patent No.:** **US D773,345 S**
(45) **Date of Patent:** **** Dec. 6, 2016**

(54) **ADJUSTABLE TORSION HITCH**
(71) Applicant: **Carl J. Borkholder**, Bremen, IN (US)
(72) Inventor: **Carl J. Borkholder**, Bremen, IN (US)
(**) Term: **15 Years**

Primary Examiner — Katrina A Betton
(74) *Attorney, Agent, or Firm* — Botkin & Hall, LLP

(21) Appl. No.: **29/536,732**
(22) Filed: **Aug. 19, 2015**
(51) **LOC (10) Cl.** **12-16**
(52) **U.S. Cl.**
USPC **D12/162**
(58) **Field of Classification Search**
USPC D12/162, 159, 160, 161
CPC B60D 1/60; B60D 1/065; B60D 1/00;
B60D 1/06
See application file for complete search history.

(57) **CLAIM**
The ornamental design for an adjustable torsion hitch, as shown and described.

(56) **References Cited**
U.S. PATENT DOCUMENTS
D326,834 S * 6/1992 Kuhlemeier D12/162
D576,085 S * 9/2008 Devlin D12/162
7,455,313 B2 * 11/2008 Yokosh B60D 1/60
150/166
D591,208 S * 4/2009 Wubker, Jr. D12/162
D620,403 S * 7/2010 Blankenship D12/162
D628,128 S * 11/2010 Sanders D12/162
2012/0049484 A1 * 3/2012 Brass B60D 1/60
280/507

DESCRIPTION

FIG. 1 is a rear isometric view of the adjustable torsion hitch;
FIG. 2 is a front isometric view of the adjustable torsion hitch of FIG. 1;
FIG. 3 is a top view of the adjustable torsion hitch of FIG. 1;
FIG. 4 is a bottom view of the adjustable torsion hitch of FIG. 1;
FIG. 5 is a left view of the adjustable torsion hitch of FIG. 1;
FIG. 6 is a right view of the adjustable torsion hitch of FIG. 1;
FIG. 7 is a front view of the adjustable torsion hitch of FIG. 1; and,
FIG. 8 is a back view of the adjustable torsion hitch of FIG. 1.

* cited by examiner

1 Claim, 4 Drawing Sheets

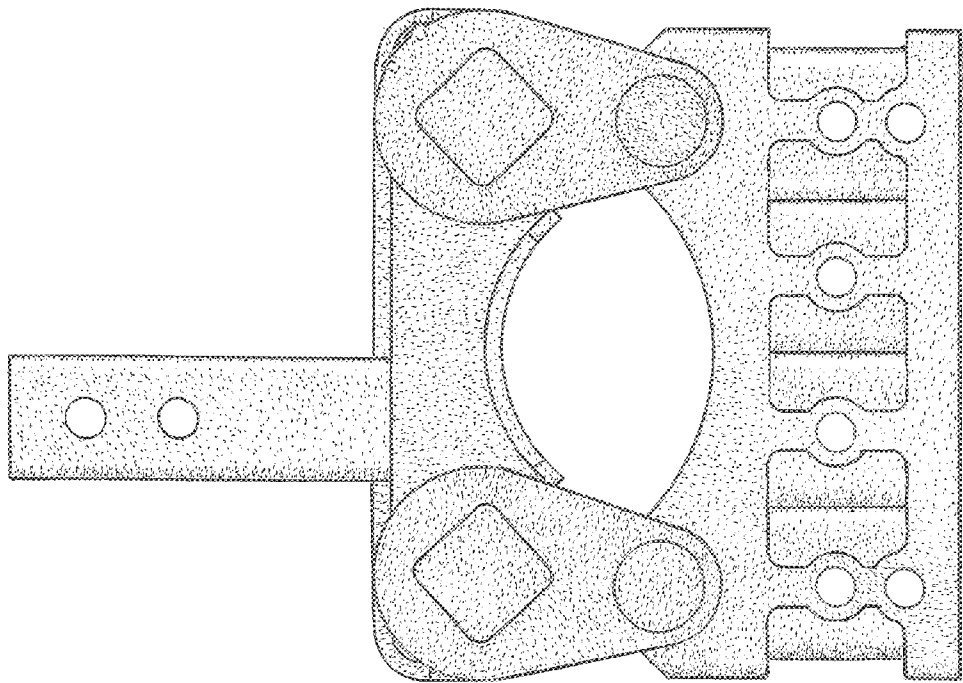

FIG. 1

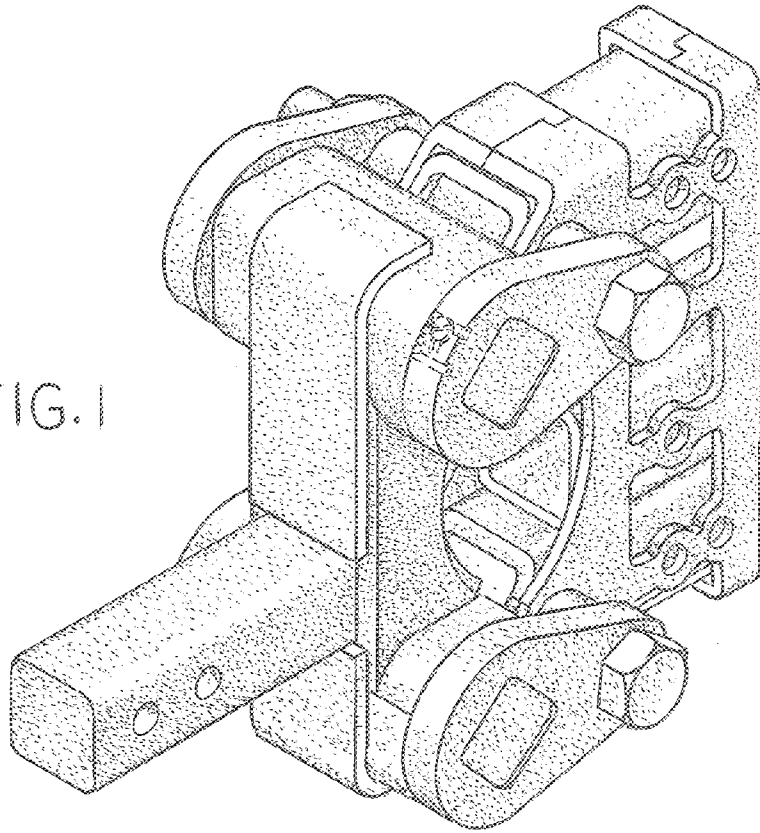

FIG. 2

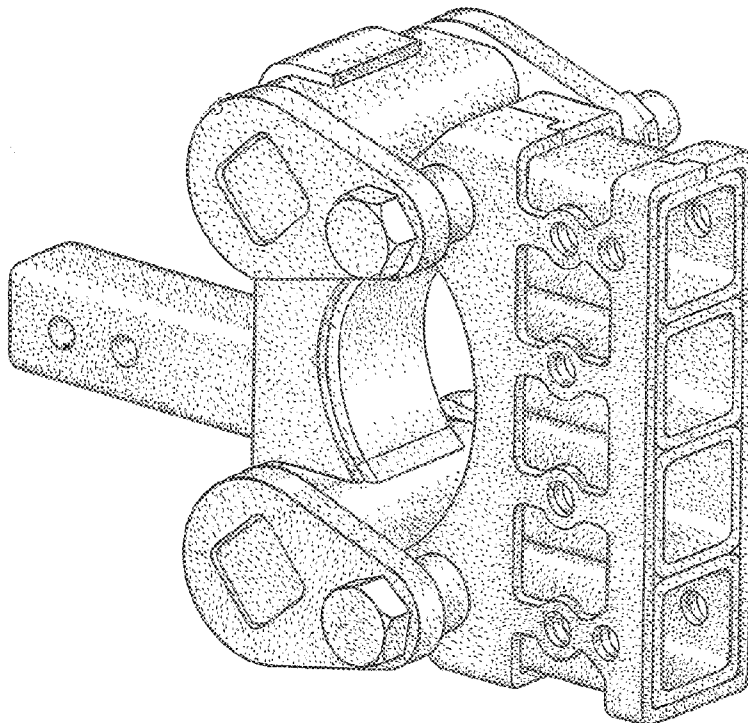

FIG 3

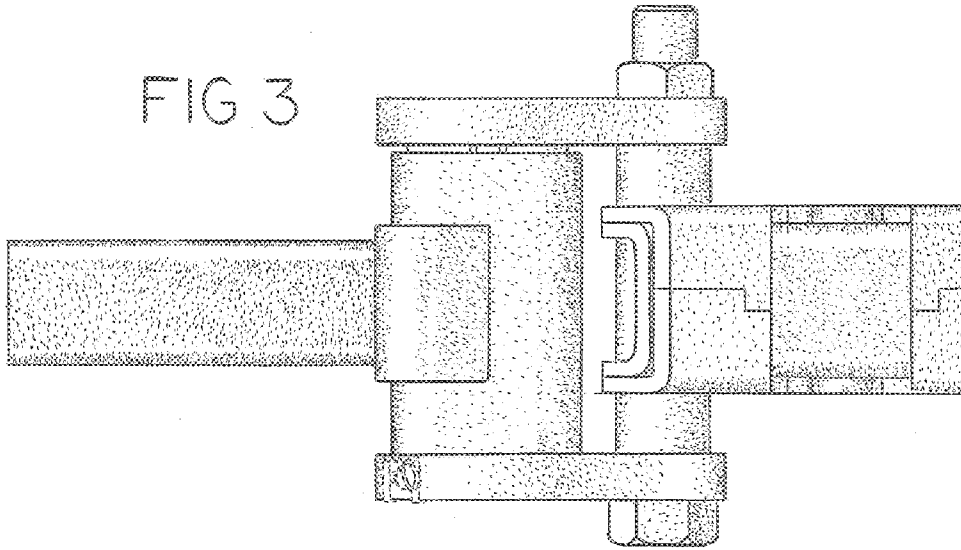
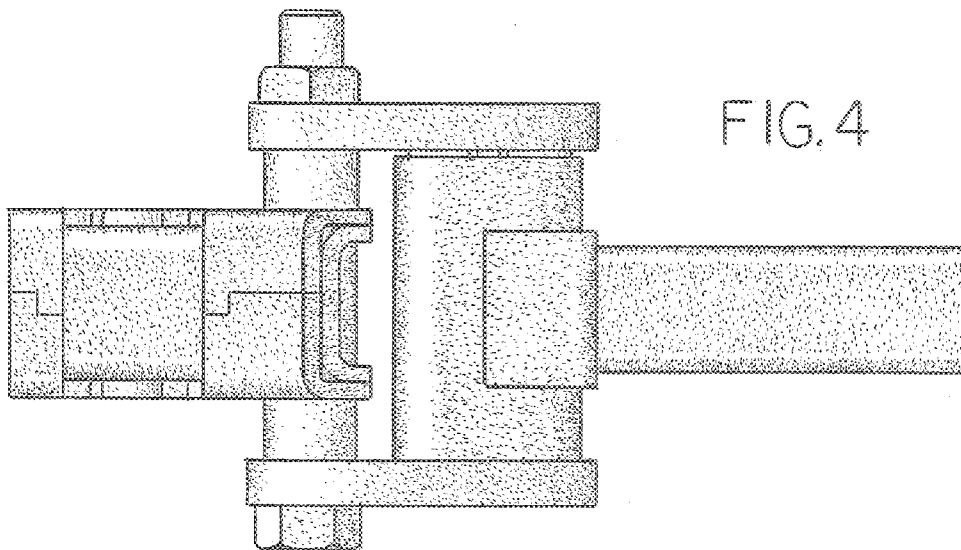

FIG. 4



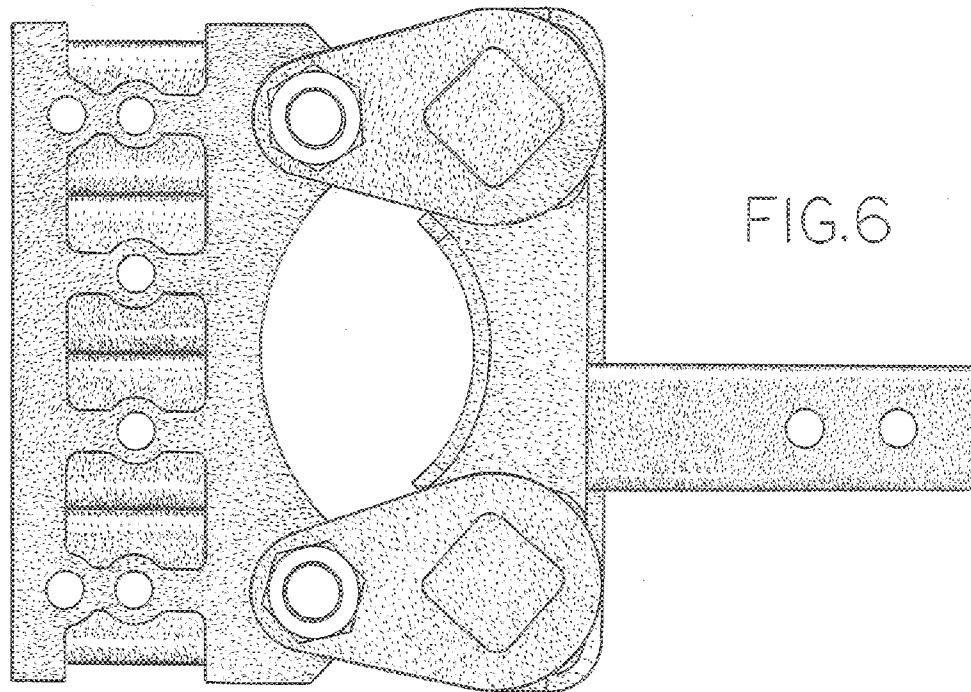
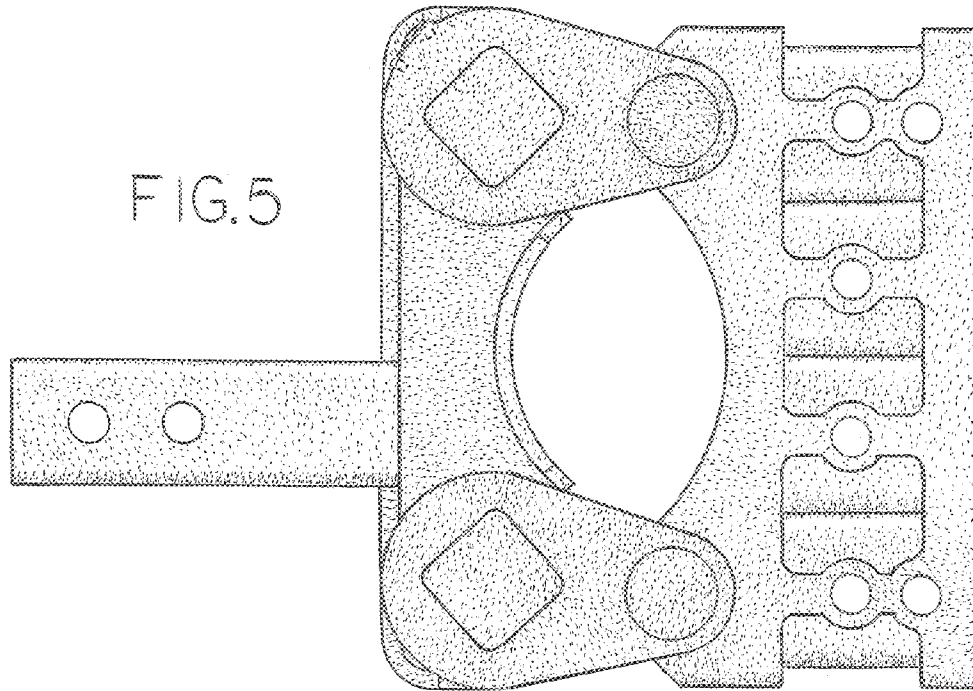

FIG.7

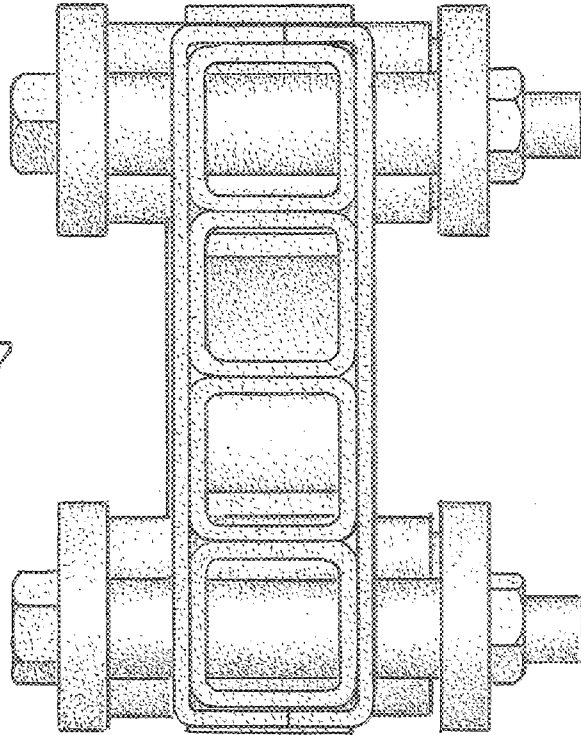

FIG 8

