

TROUBLESHOOTING GUIDE

[COOLING SYSTEM](#)

TROUBLESHOOTING GUIDE



TABLE OF CONTENTS

WHAT YOU SHOULD KNOW BEFORE YOU START

Selecting the correct replacement part is easy	6
Specialist tools make your job easier	6
The right training gives you the right know-how	6
Introduction to the cooling system and to understanding failure of the system	7

DIAGNOSING COOLING SYSTEM PROBLEMS

Always start by determining the correct part application	9
Using the proper cooling agent	10
Inspecting the hoses	12
Hose failure patterns	14
Inspecting the thermostat.....	18
Thermostat failure patterns.....	20
Inspecting the water pump	24
Water pump failure patterns.....	26
Inspecting the radiator, the expansion tank and their caps	32
Cap function check.....	36

REPLACE WORN PARTS WITH PREMIUM PRODUCTS BY GATES

Gates coolant hoses	39
Guidelines for replacing hoses	41
Stant® thermostats.....	43
Guidelines for replacing thermostats.....	44
Gates Timing Component Kits with Water Pumps.....	45
Guidelines for replacing water pumps	46
Gates radiator and expansion tank caps	47
Gates Power Clean™ Flush Tool	49
Special case: How to properly drain, flush and refill the cooling system	50

LET'S RECAP

The importance of the system	53
A reputation depends on satisfied customers	53
Review quiz	55

**A ROADSIDE FAILURE IS THE LAST THING
YOU OR YOUR CUSTOMERS NEED...**

**...ESPECIALLY WHEN THE CAR HAS JUST
BEEN IN THE WORKSHOP FOR A SERVICE.**

The information Gates has included in this troubleshooting guide will help you detect cooling system component weaknesses on liquid-cooled engines before failure, so you can keep your customers on the road.



TROUBLESHOOTING GUIDE



ID	NAME	STATUS	DATE	TIME	LOCATION	REMARKS
001	John Doe	Active	2023-10-27	08:00	Workshop A	Oil change
002	Jane Smith	Completed	2023-10-26	14:30	Workshop B	Brake pads
003	Mike Johnson	On Hold	2023-10-25	09:15	Workshop A	Engine repair
004	Sarah Brown	Active	2023-10-27	10:45	Workshop B	Tire rotation
005	David Wilson	Completed	2023-10-24	16:00	Workshop A	Wash & wax
006	Emily Davis	On Hold	2023-10-23	11:30	Workshop B	Alignment
007	Chris Miller	Active	2023-10-27	13:00	Workshop A	Fluid top-up
008	Alexander Lee	Completed	2023-10-22	07:45	Workshop B	Spark plug
009	Mia Garcia	On Hold	2023-10-21	15:15	Workshop A	Transmission
010	Noah Hernandez	Active	2023-10-27	09:30	Workshop B	Wheel bearings

WHY PROFESSIONALS CHOOSE GATES

THE ONLY THING MISSING WILL BE THAT NEW CAR SMELL

No matter where you travel around the globe, chances are when you look under the bonnet, Gates is there. Gates is one of the world's largest manufacturers and suppliers of original equipment (OE) belts and metal parts. With a century of global innovation and technology in every component, you can feel confident that Gates products will restore your customers' vehicles to factory-original condition.

Gates is the world's largest supplier of OE belts. The world's leader in OE drive design technology.

Global manufacturers that Gates supplies to includes:

- Alfa Romeo • Audi • BMW • Chrysler • Citroën • Fiat • Ford • Holden • Honda
- Hyundai • Jaguar • Kia • Land Rover • Lexus • Mazda • Mercedes • Mitsubishi
- Nissan • Opel • Peugeot • Porsche • Renault • Saab • Seat • Subaru • Suzuki
- Toyota • Lada • Volkswagen • Volvo

If all major car manufacturers use Gates parts, why shouldn't you?

TIPS AND TRICKS FROM YOUR AUTOMOTIVE SPECIALIST

So Gates provides the aftermarket with products that are of original equipment (OE) quality. But that's not all. Drawing upon our OE knowledge we anticipate the needs of the aftermarket and offer true customer support: superior cataloging, specialist tools, hands-on training seminars, comprehensive technical bulletins, detailed fitting instructions and so on.



LET US SHOW YOU HOW WE ARE THERE TO HELP YOU.

TROUBLESHOOTING GUIDE



WHAT YOU SHOULD KNOW BEFORE YOU START

GATES IS THERE TO GUIDE YOU ... EVERY STEP OF THE WAY

Correct installation of the right replacement part. That's where it all begins...

Selecting the right replacement part is easy thanks to superior cataloguing

Gates offers a better market coverage than any other automotive market player. By constantly scanning the market for new developments, our specialised application research team ensures we have the widest range. What's more, our team also provides up-to-date application data on virtually every car on the road.

All this information is freely and readily available in the Gates application catalogue range, including catalogues for Drive Belts & Components, Water Pumps, Timing Belts & Timing Component Kits and Radiator Hose.

Specialist tools ensure perfect installation and easy maintenance

In order to ensure that installation can be achieved correctly and according to the vehicle manufacturer's recommendations you also need the right tools. Without these tools, installation errors can occur. Consequences include premature component failure, damaged components or even the complete destruction of the engine itself. The last thing you want is your customer left stranded on the roadside with a vehicle failure... So, rely on our wide range of professional tools for proper installation, tensioning, alignment and maintenance.

The right training gives you the right know-how

You aim to keep your customers satisfied and eliminate costly comebacks. To do this you need more than just quality products and specialist tools. With ever-changing technology, proper training has never been more important in the automotive industry. Our technical team develops training initiatives and technical service bulletins to help keep you up to speed with the latest changes and to deal with complex problems.

WHAT YOU SHOULD KNOW BEFORE YOU START

INTRODUCTION TO THE COOLING SYSTEM

Modern engines produce more horsepower per cubic inch than they ever have in the past. The thousands of explosions in the engine each minute generate tremendous heat. In most engines however, thermal efficiency is only about 35%. Thermal efficiency is the percentage of fuel energy taken from the combustion that is actually converted into mechanical energy to power the vehicle. The rest of the energy is lost, primarily as combustion heat. About 70% of that waste heat exits through the exhaust system. The remaining 30% must be controlled by the engine's cooling system. So the primary job of the cooling system is to prevent the engine from overheating and thus avoid catastrophic engine damage. But that's not all. Engines are designed to operate within a specific temperature range for optimum efficiency. In the time it takes to reach this optimum operating temperature a car consumes more fuel, therefore emitting more CO₂ and engine parts ultimately endure more wear. Therefore, another important job of the cooling system is to make sure the optimum engine operating temperature is obtained as rapidly as possible and is then kept constant. All the parts that make up the cooling system serve both purposes and ensure the system properly absorbs, transports and dissipates heat:

- 1 The **heater core:** uses the hot coolant to generate hot air to heat the car interior.
- 2 The **radiator:** cools off the hot coolant through the process of heat dissipation.
- 3 The **expansion tank:** stores the coolant reserve and accommodates the changes in coolant volume as the coolant goes through its cycle of heating up (expanding in volume) and cooling down (reducing in volume) by holding expanded coolant from the cooling circuit.
- 4 The **fan:** draws external fresh air onto the radiator as necessary to assist in heat dissipation (e.g. during idling time in traffic).
- 5 The **thermal switch:** operates with the coolant temperature variation and switches on the fan as necessary to support the cooling by airflow.
- 6 The **cooling system hoses:** carry the coolant through the entire cooling circuit. The coolant acts as either an engine-cooling or interior-heating source, depending on the part of the circuit it is in.
- 7 The **thermostat:** regulates the coolant flow to obtain and maintain the optimum engine operating temperature.
- 8 The **water pump:** constantly circulates the coolant throughout the entire cooling circuit, regulating the coolant flow rate.
- 9 The **radiator cap** and the **expansion tank cap:** seal off the filling hole of the radiator/expansion tank gastight; ensure that the prescribed pressure on the system is maintained at all times during operation by allowing air to escape in case of overpressure.

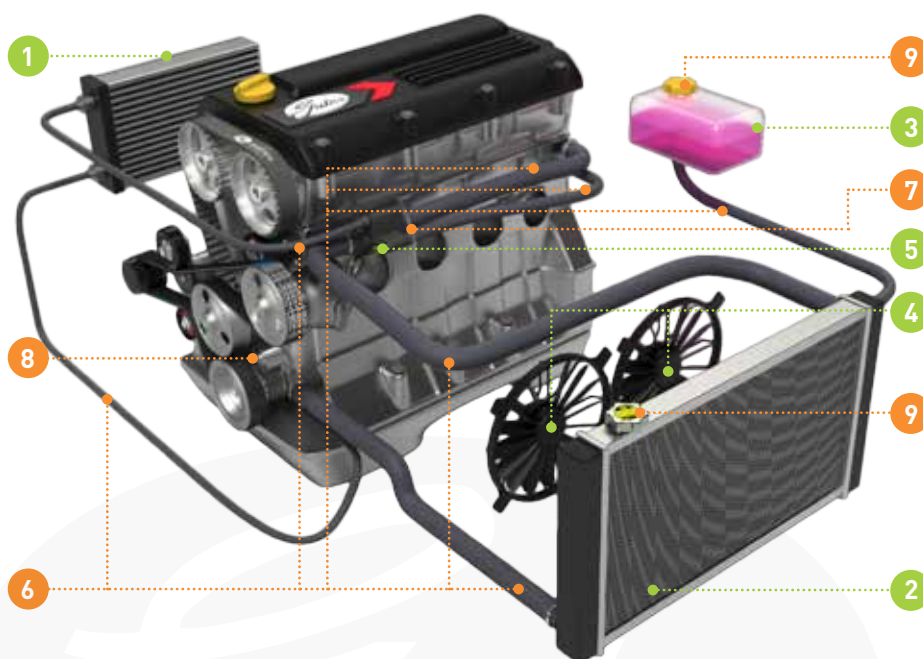

WEAR PARTS / HARD PARTS

UNDERSTANDING FAILURE OF THE COOLING SYSTEM

Anything that decreases the system's ability to absorb, transport and dissipate heat can cause the engine to operate at reduced efficiency or even overheat: a low coolant level, kinked hose, defective thermostat, corroded water pump, worn pressure cap... In other words, the engine can only be kept safe from overcooling or overheating when every single cooling system component functions perfectly. The coolant has to get rid of the heat it absorbs while passing through the hot engine block. This requires a well-functioning radiator to make sure the heat absorbed by the coolant is dissipated to the outside air. But also the hoses, thermostat and water pump are essential. A kinked hose will reduce the flow of coolant. A defective thermostat can block the coolant circulation. A corroded water pump will be ineffective in moving the coolant. Even a component as small as the pressure cap is critical. A worn pressure cap will not properly pressurise the system which can compromise the proper functioning of the entire system.

The main objective of this guide is to identify cooling system component weaknesses before failure, so you can prevent your customers from suffering troubles such as poor cabin heater power on a freezing winter morning, bad fuel mileage or even worse... a roadside breakdown on a hot summer day.

Expensive, inconvenient repairs can be avoided as Gates tells you where and how to look for potential issues!

All of which is good news for you, since this improves the customer satisfaction levels for your garage.



DIAGNOSING COOLING SYSTEM PROBLEMS

DIAGNOSING COOLING SERVICE PART RELATED PROBLEMS

Now we are ready to go into more detail.

When experiencing any operational issues, use the following troubleshooting methods to resolve the problem.

Always start by determining the correct part application

Always double-check all parts to ensure that the proper coolant hoses, thermostat, water pump etc. are installed for the particular vehicle and engine in question. Parts which are not made to the proper specifications may cause the entire system to malfunction. Be certain that all parts are designed for the specific application and installed properly. If any component within the cooling system has been recently replaced, check that part for correct installation. Any component installed improperly can result in less than optimum performance.

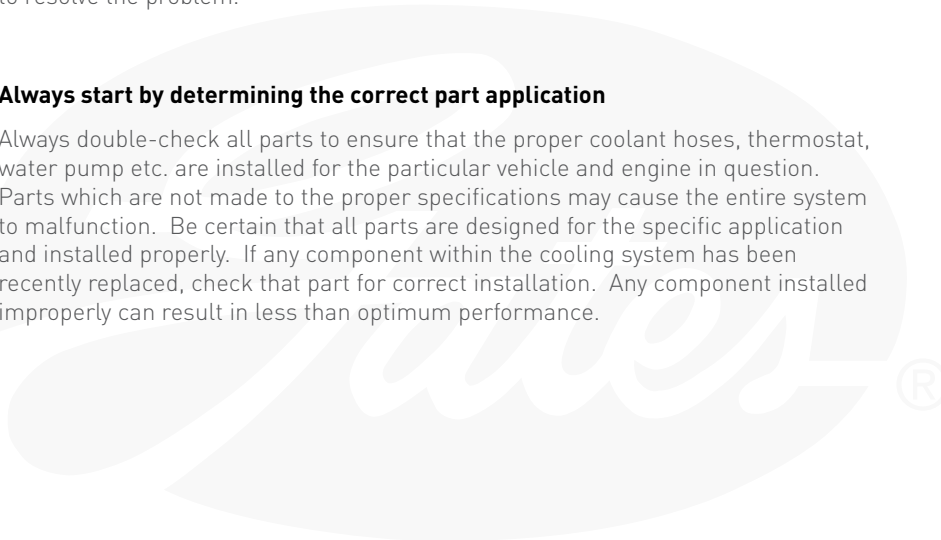

Using the proper cooling agent

As the cooling agent is the “fluid connection” between the cooling system components, it is to be considered as a vital “part” of the system deserving your full attention. Engine coolant has several functions: absorb engine heat, provide freeze protection, and help raise the boiling point (engine cooling is based on the principle that pressurised fluid starts to boil at higher temperatures than non-pressurised fluid, see also page 34). In addition to protecting the engine from extreme temperatures, the coolant protects the cooling system from rust and corrosion as it contains anti-rust agents, corrosion inhibitors and a lubricant for the water pump, all of which keep the cooling system components operating smoothly.

Understanding coolant technology and selection

As with engine oils, modern vehicles now require vehicle-manufacturer-specific coolants. The cooling system is considerably more complex than it once was, and incorporates components made from many different materials. The need to protect these components from rust and corrosion is the key reason behind the growth of vehicle-manufacturer-approved coolants.

Coolants fall into four non-interchangeable types, as each type is designed to work differently:

TYPE		PROTECTION TECHNOLOGY
Inorganic Additive Technology	IAT	silicate / phosphate
Organic Acid Technology	OAT	organic acid
Hybrid Organic Acid Technology	HOAT	organic acid with silicate
Phosphate Hybrid Organic Acid Technology	PHOAT	organic acid with phosphate

Inorganic additives are used to plate cooling system surfaces as they form a thick protective layer but deplete over time. They are not very selective, which means they cover all surfaces regardless of what these surfaces are made of. Organic additives form chemical bonds with vulnerable surfaces, making a thin though extremely stable protective layer offering longer protection. They are selective, targeting only the areas that need protection.

Coolant selection would be easy if all vehicle manufacturers developed their systems with the same materials. But as that is not the case, each manufacturer develops a factory fill coolant based on the cooling system component materials it contacts.

So, choosing the proper replacement coolant is impacted by the cooling system design. That is why Gates recommends to always replace the vehicle’s coolant with the coolant recommended by the vehicle manufacturer.

One coolant cannot work for all vehicles!

DIAGNOSING COOLING SYSTEM PROBLEMS

Coolant level check and change

Check the coolant level whenever a car comes in for service. A low coolant level has a harmful effect on the cooling system components, and can result in engine-damaging temperatures. The level should be filled between the "maximum" and "minimum" marks on the side of the reservoir. If the level is near or at the marked minimum level, top up the system with the vehicle manufacturer's recommended coolant, or if not available, distilled water (max. 2% of the total coolant volume). Don't top up with tap water or non-compatible coolant. Tap water varies in pH and mineral content; it throws the coolant chemistry out of balance and, when heated, percolates out and forms deposits that block cooling system passages. Non-compatible coolant reduces the original protection level. Also, always look for the root cause of coolant loss (see also pages 15, 20, 26-27 and 33).

When doing a coolant change, Gates recommends a complete change with the vehicle manufacturer's recommended coolant. Mixing different types of coolants or putting the wrong type of coolant in the system may void car warranties. Always drain and flush the system – using an approved flush tool (see also page 50) – before refilling. Use pre-mix coolant or mix new coolant with distilled water in the ratio recommended by the vehicle manufacturer.

And last but not least, coolant should be changed at least every two years or 50,000 km (31,000 miles) as a good preventive maintenance procedure, or it will lose effectiveness. Also, if you are unsure of the coolant in the system, drain and flush the system and refill with new coolant.

Special note: Looks can be deceiving

Sometimes coolant may look clean, but if the system has never been flushed and mileage is high, it is probably contaminated. Not all contaminants make the coolant look dirty. Sand and other abrasive debris particles, aluminium corrosion particles and mineral content in the water, to cite three examples, won't be obvious. Also, do not rely on the coolant colouring to make your pick. Coolants may have the same colour, even though ingredients are different. The function of the dye is to help you spot a coolant leak. The right answer to what coolant to use when, is: always use the vehicle manufacturer's recommended coolant.

Keep in mind that a cooling system drain, flush and refill is meant to prevent problems, not to fix them!

Changing the coolant is good preventive maintenance but will not be sufficient. Gates advises a thorough inspection of all cooling system components at each service interval to identify component weaknesses before failure.

Refractometer

Ensures adequate freeze and boil-over protection by accurately testing glycol concentrations of radiator coolant. Maintains effective cooling system performance and eliminates risks of engine damage from electrolysis, cavitation and corrosion. Also measures state of charge and specific gravity for electrolyte in lead-acid batteries.

Part # 91001



Inspecting the hoses

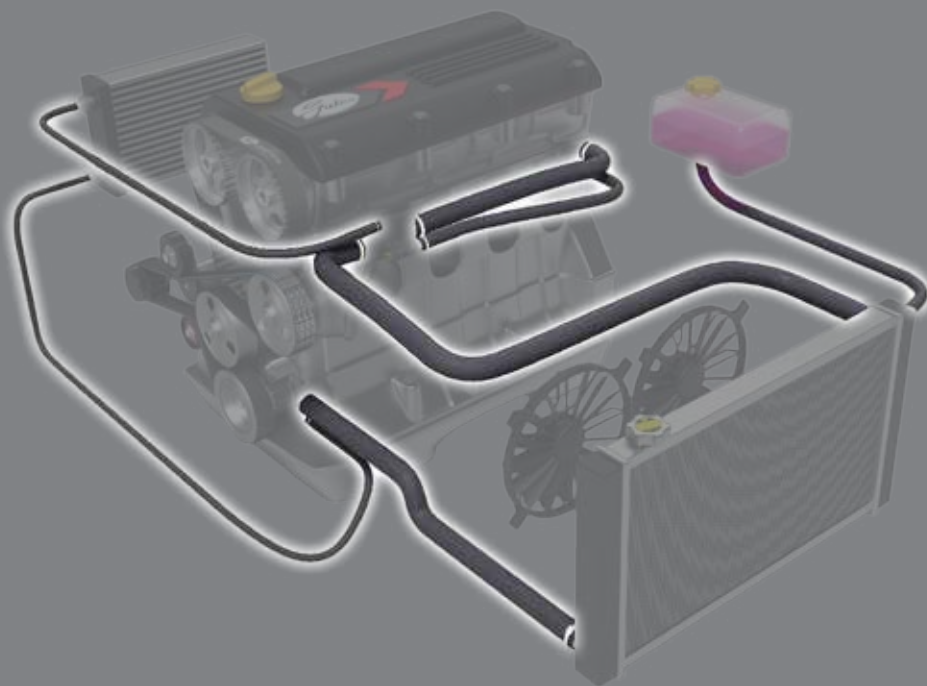

When engines used to be less complicated, a typical workshop had to carry only a few sizes and types of coolant hoses. But with today's smaller engine compartments, coolant hoses come in all shapes and sizes to fit specific applications and tight engine spaces. They carry coolant to a variety of under-bonnet equipment and not just to the radiator, thermostat, water pump and heater core. In addition to the traditional upper, lower, by-pass and heater hoses, vehicles are also equipped with small coolant hoses that carry coolant to the fuel injection throttle body, turbocharger, oil cooler and other components.

Although coolant hose applications have changed over the years, basic hose design has not. Hoses consist of three parts: the tube, reinforcement and cover. The tube conveys the coolant, and the reinforcement prevents the tube from rupturing under pressure. The outer cover protects the entire hose assembly from harsh external environments and contaminants. These three components are bonded together by special adhesives.

DIAGNOSING COOLING SYSTEM PROBLEMS

Expected hose life

While basic hose design has remained relatively unchanged over the years, hose materials have improved substantially. Thanks to these improvements hoses last longer today than before. Yet, their harsh working environment will inevitably affect them and over time even the best hoses will wear. And when they do so, they usually fail from the inside due to electrochemical degradation (see also page 14). As there is no way to tell from a simple visual inspection if a coolant hose has internal damage and statistics show that failures increase dramatically after the fourth year of service, Gates recommends that coolant hoses be replaced at least every four years or 100,000 km (62,000 miles).

Hoses can fail faster

While the four-year replacement interval is a basic rule of thumb, it is not exact. Vehicles operating under severe conditions or vehicles that are not driven often may require more frequent replacements. Therefore, it is imperative to periodically inspect hoses – even hoses less than four years old – for damage from the major hose enemies electrochemical degradation, leakage, heat, ozone, abrasion, and oil contamination whenever a vehicle comes in for service. If the hose exhibits any of the tell-tale signs of wear, it should be replaced immediately. See pages 14-17 for failure patterns.

Don't forget the clamps and connectors

Check each clamp and connector, and replace any that are defective. Gates recommends replacing clamps and connectors each time a new coolant hose is installed. Hose clamps come in very different types, each designed to meet different hose specifications. It is important to make sure you have the correct style and size of hose clamps at hand when you install new hoses.

Gates has coolant hoses in its range that are electrochemical resistant (ECR), delivering longer-lasting service for your customers and building a reputation of reliability for your shop!

Not all OE manufacturers use ECR hose, so if you choose a Gates ECR hose as a replacement you are using the highest quality product on the market. This will strengthen your reputation with your customers.

Read more about Gates extensive line-up of coolant hoses on pages 39-40.

Cooling System Pressure Tester

The Stant™ Cooling System and Cap Pressure Tester is a precision instrument designed to locate leaks and pressure cooling system problems. It has the ability to test up to 30 pound cooling systems and pressure caps. Adapters for most vehicles and trucks are also available separately.

Part # 12270



Hose failure patterns

Some general guidelines to start your hose inspection:

- › **Always check for kinking**
When inspecting a coolant hose for damage, make sure that it is not kinked, and is not touching hot or moving engine parts or sharp edges. A kink can reduce the flow of coolant and cause the engine to overheat. A sharp surface may eventually cut or abrade through the hose, resulting in a loss of coolant.
- › **Additional tip: checking the hose temperature can reveal if the system is functioning properly**
Let us give you some examples. Use an infrared thermometer to read the hose temperature. If the heater is on, both the ingoing and outgoing heater hoses should be close to the same temperature. If not, it might be time for a repair. If the upper radiator hose already gets hot before the engine has properly warmed up, it means the thermostat is not closing properly or even is constantly open. If it does not get hot at all, it means the thermostat is blocked. In both cases, the thermostat should be replaced immediately.

The following signs indicate that a hose needs to be replaced:

The engine should be cool before any repair work is started!

1. Electrochemical degradation (ECD) – internal damage



Appearance: Electrochemical degradation is the **number one cause of hose failure**. ECD weakens the hose from the inside and is therefore not obvious by visual inspection. Do the “squeeze test”: ECD initially attacks the hose 5 to 10 cm (2 to 4 inches) from the ends so first squeeze both end sections using your thumb and one or two fingers. Then squeeze the middle straight section of the hose, checking for a detectable difference between the ends and the middle. If the ends feel more soft and mushy or if you feel gaps or channels inside the hose, the hose is most likely under attack by ECD.

Cause: ECD occurs when different kinds of metals in the cooling system generate an electrical charge, which is carried from one component to another by the coolant. In case of high concentration, this electrical charge will affect the hose tube, creating tiny internal cracks, which weaken the hose.

Solution: Replace the damaged hose immediately. The best way to avoid ECD failure is to install a hose that fights ECD. Gates electrochemical resistant hoses are your best protection against electrochemical degradation.

DIAGNOSING COOLING SYSTEM PROBLEMS

2. Leakage



Appearance: Moisture, drips or coolant bleed marks on or around the hose clamps, connectors or on the hose itself.

Cause: Leakage is usually caused by insufficient clamp torque or a deteriorated connector. Heat causes metal to expand. If a new hose is installed while the engine is still warm, the expanded diameter of the inlet or outlet tubes prevents the clamp from tightening as much as it needs to. Heat also causes the rubber hose to expand – about 20 times more than the metal. The clamp holds the hose on the tube, but the hose “sets” in this expanded state. Then when the engine cools off, a gap appears between the “set” ID of the hose and the contracted OD of the metal tube, and the coolant leaks. Other than clamp or connector failure, leakage can be caused by a deteriorated hose itself.

Solution: Hose suggestions: Replace with the recommended Gates hose. Gates uses compounds that offer better resistance to the negative effects of compression set.

Clamp torque suggestions: To avoid cold water leaks, adjustable tension clamps must be retightened after a brief run-in period. Another solution is to use constant-tension clamps, which automatically adjust with the heating and cooling of the system.

Connector suggestions: A beaded connector offers better sealing and retention characteristics. The smoother the finish of the connector, the less tendency to leak under the clamp. Brass and cast iron fittings adhere to common rubber compounds after time, which reduces possibility of leaks, as does the use of sealants and viscous gels.

3. Heat damage



Appearance: Heat damage can occur both internally and externally. Slight swelling is one sign of internal damage. If the interior yarn has been severely damaged by the heat, the hose will feel soft and may even bulge in places. External heat damage is easier to detect since heat-damaged hoses typically have a hardened, glossy cover that is covered with cracks.

Cause: As engine compartments become smaller and more compact, temperatures under the bonnet increase. Ambient temperature from nearby hot engine parts, low coolant levels and/or temperature spikes also contribute to deterioration.

Solution: Replace with the recommended Gates hose. Gates hoses are specially designed to resist deterioration from heat. ®

4. Ozone damage



Appearance: Tiny, parallel cracks in the cover, usually at hose bends.

Cause: Increased concentrations of ozone, caused by pollution, attack the bonds in certain rubber compounds. Tiny cracks occur, primarily where the hose experiences stress: curves, bends and at clamping surface areas. These cracks allow contaminants to invade and destroy the hose.

Solution: Replace with the recommended Gates hose. Gates hoses are made of EPDM and are unaffected by ozone.

DIAGNOSING COOLING SYSTEM PROBLEMS

5. Abrasion damage



Appearance: Abrasion can be identified by rubbing marks on, or damage to, the hose cover.

Cause: Abrasion damage is caused by hose rubbing against other engine parts or against objects in the environment. A hose can, for example, be abraded by coming into contact with a part that was accidentally moved during maintenance or repair, or after hitting a speed bump. In other cases, abrasion occurs after the OE hose guiders have broken or after a hose is no longer properly seated in the guider.

Solution: Replace the hose. If the hose is resting on or will come into contact with a sharp surface, or is near a heat source, try one of the following:

1. Reroute the hose away from the point of contact or replace/repair the hose guiders if needed
2. If that is not possible, slightly twist the hose on one or both spouts to reroute the hose away from the surface
3. As a last resource, wrap a protective sleeve around the new hose at the point of contact – Gates advises against using a slit piece of an old hose, as this will negatively influence the system's overall temperature.

6. Oil contamination



Appearance: The hose feels soft or spongy to the touch. Bulges and swelling are readily apparent.

Cause: Oil reacts chemically with the hose compounds and weakens the molecular bonds. This causes the hose to soften, swell and separate, layer by layer, leading to failure.

Solution: Replace the hose and eliminate any source of oil. If this is not possible, reroute the hose.

Inspecting the thermostat

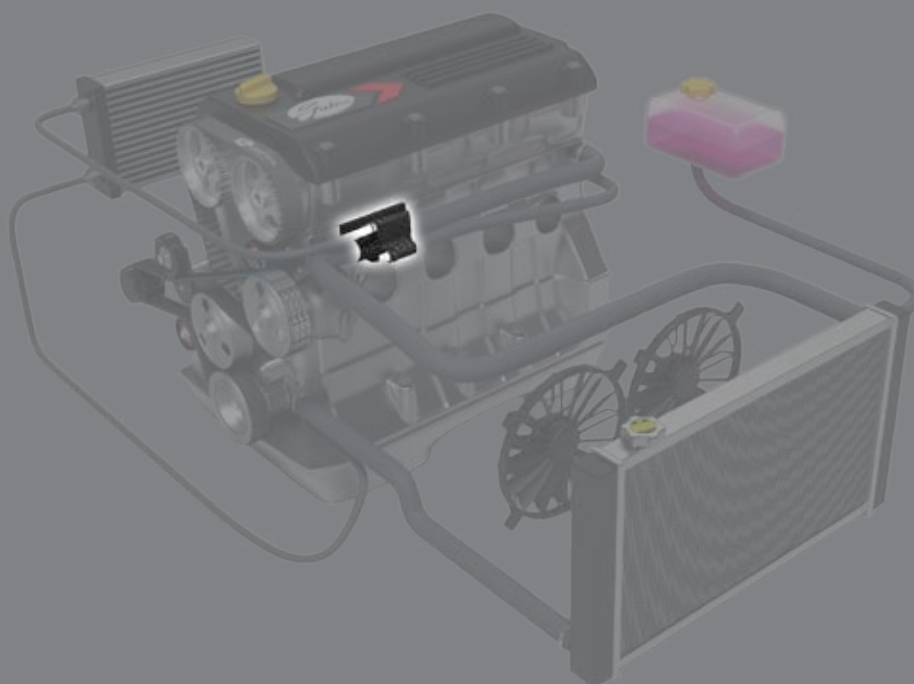

Different combustion engine technologies call for different thermostat types, but basically all thermostats do the same thing. They are the watchdog of the engine's cooling system, as they constantly monitor the temperature of the coolant and accurately regulate the coolant flow through the radiator to obtain and maintain the optimum engine operating temperature.

In its starting position, the thermostat is closed and blocks the flow of coolant to the radiator until the engine has warmed up. Once the engine rises to running temperature and the coolant reaches the thermostat's activation temperature, the thermostat opens, allowing the hot coolant out of the engine and starting the circulation loop to and from the radiator. The hot coolant passes to the radiator and the cool coolant enters the engine to absorb more heat. The thermostat continues this opening and closing as long as the engine requires.

DIAGNOSING COOLING SYSTEM PROBLEMS

Scenarios for thermostat failure

Thermostats, like any other part, don't last forever. There are two scenarios for failing thermostats:

1. If the thermostat becomes stuck in the open position, there is continuous flow of coolant into the radiator causing the engine to run cold. Overcooled engines run inefficiently, which leads to increased fuel consumption and higher emission levels and engine parts enduring more wear. In addition, the car interior will not heat up properly.
2. If the thermostat becomes stuck in the closed position, the circulation of the coolant is blocked so the coolant cannot get to the radiator to be cooled which causes the engine to overheat.

In this context, map-controlled thermostats deserve a special mention. Map-controlled thermostats are a growing trend in OE (see also page 22). In standard operation they function like traditional thermostats but in the event of specific engine load conditions electrical heating of their wax element is triggered by the engine electronics control unit, pro-actively opening the cooling circuit towards the radiator even though the temperature has not actually risen yet. In that respect, map-controlled thermostats can not only suffer a "traditional open or closed failure" (as described above) but can also dysfunction because of a damaged connection to or an electronic malfunction of the engine electronics control unit.

It is difficult to tell if a thermostat is ready to fail by visually inspecting it so it is best practice to service it preventively. See pages 20-23 for failure patterns.

Facts to know about thermostat replacement

Replacing the thermostat when you replace related faulty parts in the cooling system is good preventive maintenance for several reasons. Firstly, not every case of thermostat ageing is clearly evident in the form of an obvious failure pattern. Secondly, thermostat failure is usually age- and mileage-related, and it is a given that normal failure may occur differently on different applications. And thirdly, it should be clear by now that a thermostat which must be replaced may not have failed completely. The consequences of an "open failure" may be less catastrophic than those of a "closed failure" but are nevertheless undesirable for your customer.

That's why Gates recommends replacing the thermostat when you replace related parts in the cooling system, because any loss of functionality or even complete failure can have severe consequences.

Don't forget the gaskets and seals

Old gaskets and seals should be replaced by new ones. Carefully follow installation instructions. Only apply sealant if specifically recommended by the vehicle manufacturer. Put an even bead of sealant along the edge of the part, but don't use too much sealant. If you do get too much sealant on the part, wipe off the excess before mounting the new thermostat. Too much sealant compromises the correct installation and will break off within the cooling system, contaminating it. Sealants are also made with different drying rates, so respect the sealant's printed instructions.

Thermostat failure patterns

The following signs indicate that a thermostat needs to be replaced:

If an engine has overheated because of another problem, the thermostat should always be replaced!

1. Leakage from the mounting surface



Appearance: Seepage, drips or large coolant bleed marks on or around the mounting surface or on the housing.

Cause: Improper thermostat installation, e.g. wrong torque of the mounting bolts. Improper use of seals/gaskets or sealant, e.g. unevenly applied sealant.

Solution: In case of a recently installed new thermostat: carefully remove, check and re-install the thermostat (see also page 44). Strictly follow the torque specifications. Make sure seals/gaskets are in perfect condition and are installed correctly. When sealant is prescribed, clean the rims of the part and the mounting surface from old sealant remains and apply new sealant evenly along the edge of the part (see also page 19). If the leakage is not the consequence of an improperly installed new thermostat, the thermostat must be replaced immediately.

DIAGNOSING COOLING SYSTEM PROBLEMS

2. Rust and corrosion



Appearance: Rust and corrosion on the surfaces of the thermostat. Chemical reactions eat away at the thermostat, leaving small holes and/or creating particles that act as an abrasive agent in the cooling circuit (particularly at spots where the flow is redirected and in narrow channels), destroying the thermostat's individual components.

Cause: Contaminated coolant, non-compatible coolant or mixing coolants of different chemistries. Other possible cause may be a defective pressure cap: if the system is not properly pressurised coolant might start to boil, causing air bubbles. Any air that gets in accelerates the rust process.

Solution: Replace the thermostat. Thoroughly flush the cooling system before installing the new thermostat and refill the system with the correct vehicle manufacturer's recommended coolant (see also pages 10-11 and 50-52). Inspect the pressure cap (see also pages 35-36) and replace if defective.

3. Deposit build-up



Appearance: Deposits, sludge and scale build up on the inside, clogging the thermostat and hampering proper functioning of its individual components.

Cause: Contaminated coolant, non-compatible coolant or mixing coolants of different chemistries.

Solution: Replace the thermostat. Thoroughly flush the cooling system before installing the new thermostat and refill the system with the correct vehicle manufacturer's recommended coolant (see also pages 10-11 and 50-52).

4. Map-controlled thermostats – a growing trend in OE



Appearance: Map-controlled thermostats have an electric heating resistor integrated into their wax element. Electrical heating of the wax element is triggered when the engine is exposed to specific load conditions and the engine management system anticipates an increase in waste heat. Map-controlled thermostats can dysfunction because of a “traditional open or closed failure” (as described on page 19) but also because of a damaged connection to or an electronic malfunction of the engine electronics control unit.

Solution: Check the plug for damage or corrosion and replace if defective. If this does not solve the problem, check the fault codes of the engine management system. Also check the thermostat for the traditional failure patterns mentioned previously and replace where necessary.

DIAGNOSING COOLING SYSTEM PROBLEMS

How can you test a thermostat to see if it is working properly?

.....

On-vehicle testing

- › The engine should be at ambient temperature (not running temperature) before starting the test.
 - › Start the engine.
 - › Have someone keeping an eye on the temperature gauge in the dashboard while you use an infrared thermometer to read the temperature of the upper radiator hose.
 - › Before the temperature gauge reaches its normal position (= during the engine warm-up phase), the temperature of the upper radiator hose should only show a slow temperature increase due to the rising radiant heat. If the hose gets considerably hot before that (15°C-20°C above ambient temperature), it means that the thermostat is either not closing properly or is constantly open.
 - › When the temperature gauge reaches its normal position (= when the engine has properly warmed up), the temperature of the same hose should rise rapidly ($\pm 45^\circ\text{C}$ above ambient temperature). If this is not the case, it means the thermostat is blocked.
 - › A thermostat that is stuck in the open or in the closed position should be replaced immediately.
 - › If there is no temperature gauge in the dashboard, use the infrared thermometer to monitor the change in temperature right before and after the thermostat housing. The temperature difference between those two locations should first rise rapidly and then disappear completely once the engine is at running temperature.
-

Off-vehicle testing

- › Check the thermostat specifications to know its proper opening temperature.
 - › Put the thermostat in a pot of water, along with a thermometer able to withstand $+120^\circ\text{C}$, and heat up the water. The maximum allowable water temperature is the thermostat's opening temperature plus 10°C .
Special note for map-controlled thermostats: make sure that the contact surface remains dry.
 - › The thermostat should fully open. If not, it needs replacement.
 - › Afterwards put the thermostat in a pot with cold water and check if the thermostat fully closes again. If not, it needs replacement.
-

Inspecting the water pump

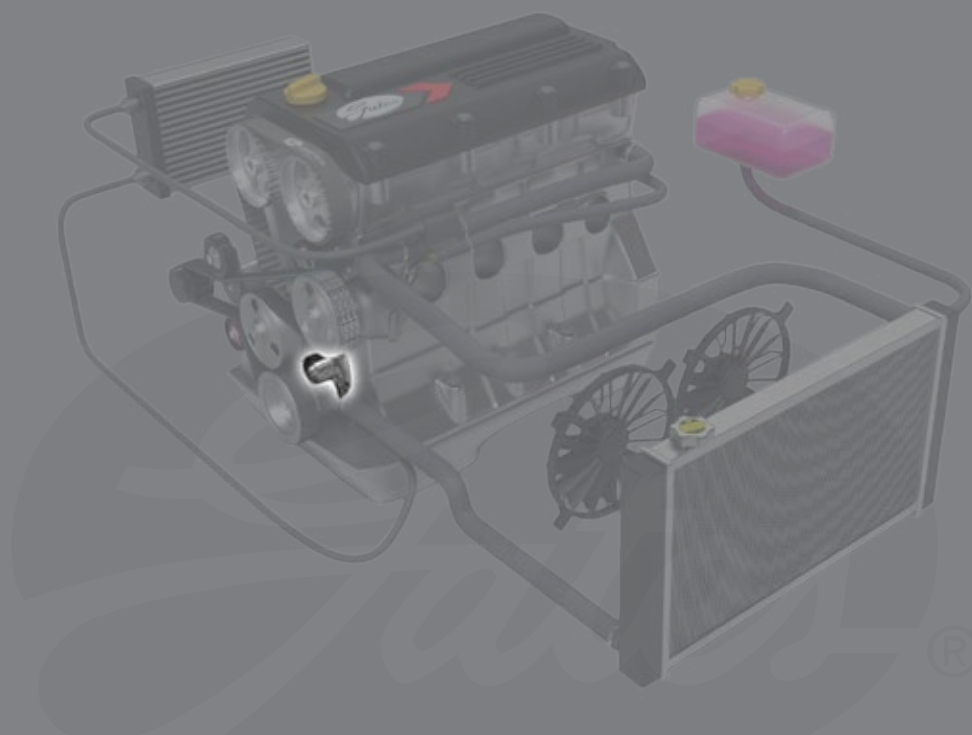

The water pump is the heart of the engine's cooling system. It is the water pump's job to constantly circulate the coolant throughout the entire cooling circuit and thus regulate the coolant flow rate.

A paddle-style impeller rotating on a bearing-supported shaft is responsible for moving the coolant. The impeller shaft is most commonly driven externally by a pulley/belt combination.

DIAGNOSING COOLING SYSTEM PROBLEMS

Identifying a worn water pump

Wear affects not only the hoses and thermostat but also the water pump. Water pump failure can be the result of a worn bearing, which will manifest itself through abnormal noise. Another cause of failure is leakage. When this happens, you can see evidence of a leak coming from the weep hole or the mounting surface of the water pump. Minor seepage from the weep hole is normal during the pump's break-in period (see also page 26) but should stop soon after. Water pumps can also fail internally due to deposit build-up, or severe corrosion wearing away the impeller fins, or the shaft itself may break. See pages 26-31 for failure patterns.

Facts to know about water pump replacement

The average water pump handles 1.7 million litres of coolant in about four years or 100,000 km (62,000 miles) of driving. But pumps can fail faster, and a failing pump can cause an engine to overheat. Therefore, it is important to check the water pump at each service interval. But it is equally important to inspect the belt drive system that is driving the water pump. A malfunctioning belt and tensioner cause premature bearing and shaft failure and as such drastically reduce pump life. Conversely, a leaking water pump inevitably affects the belt and tensioner. That is why Gates recommends changing the water pump, belt and other drive components at the same time as good preventive maintenance.

Don't forget the gaskets and seals

Old gaskets and seals should be replaced by new ones. Carefully follow installation instructions. Only apply sealant if specifically recommended by the vehicle manufacturer. Put an even bead of sealant along the edge of the part, but don't use too much sealant. If you do get too much sealant on the part, wipe off the excess before mounting the new water pump. Too much sealant compromises the correct installation and will break off within the cooling system, contaminating it. Sealants are also made with different drying rates, so respect the sealant's printed instructions.

Special note: Don't use coolant additives

Use a premium-grade coolant (see also page 10). It contains everything the engine needs. Adding an additional lubricant does not improve pump performance. It does just the opposite. The chemical balance of a premium-grade coolant offers all the lubrication the water pump needs.

Be safe! Replace the water pump, belt and other drive components at the same time!

Gates water pumps are included in the all-in-one Gates Timing Component Kit with Water Pump – kits that come complete with all the parts necessary for a complete overhaul of the synchronous belt drive system. Why? To do the job right the first time and avoid comebacks! Because you simply cannot guarantee that the old water pump will last the life of the new belt and tensioner. Plus, it takes about 2-4 hours to overhaul the system regardless of whether or not the water pump is replaced, so why tear the engine apart twice if you can do both jobs at once?

Read more about Gates Timing Component Kits with Water Pumps on page 45.

Water pump failure patterns

The following signs indicate that a water pump needs to be replaced:

1. Weep hole leakage



Appearance: The pump's internal mechanical seal seals the shaft towards the cooling circuit, protecting the bearings by preventing coolant from passing into the bearing assembly. When a water pump is new, some seepage from the weep hole is normal as it takes about ten minutes of operation for the mechanical seal to properly seat itself (break-in period). More pronounced seepage and drips from the weep hole after this break-in period or a large coolant bleed mark around the weep hole are abnormal and indicate impending water pump failure.

Cause: Contaminated coolant is the main cause of leakage: any contaminant (abrasive particles, engine oil...) present in the coolant that scratches the mechanical seal or affects its wear resistance creates a path for coolant leakage. Also, never dry run a water pump, not even for a few seconds. Dry running of the pump ruins its mechanical seal (see also page 46).

Solution: Any leakage from the weep hole after the break-in period means the water pump must be replaced immediately. It is very important to thoroughly flush the cooling system before installing the new pump and to refill the system with the correct vehicle manufacturer's recommended coolant (see also pages 10-11 and 50-52).

DIAGNOSING COOLING SYSTEM PROBLEMS

2. Leakage from the mounting surface



Appearance: Seepage, drips or large coolant bleed marks on or around the mounting surface or on the housing.

Cause: Improper water pump installation, e.g. wrong torque of the mounting bolts. Improper use of seals/gaskets or sealant, e.g. unevenly applied sealant.

Solution: In case of a recently installed new water pump: carefully remove, check and re-install the water pump (see also pages 46-47). Strictly follow the torque specifications. Make sure seals/gaskets are in perfect condition and are installed correctly. When sealant is prescribed, clean the rims of the part and the mounting surface from old sealant remains and apply new sealant evenly along the edge of the part (see also page 25). If the leakage is not the consequence of an improperly installed new water pump, the pump must be replaced immediately.

3. Rust and corrosion



Appearance: Rust and corrosion on the surfaces of the water pump. Chemical reactions eat away at the water pump, leaving small holes and/or creating particles that act as an abrasive agent in the cooling circuit (particularly at spots where the flow is redirected and in narrow channels), destroying the pump's individual components. A typical example here is corrosion that attacks the impeller fins and makes the pump ineffective in moving the coolant.

Cause: Contaminated coolant, non-compatible coolant or mixing coolants of different chemistries. Other possible cause may be a defective pressure cap: if the system is not properly pressurised coolant might start to boil, causing air bubbles. Any air that gets in accelerates the rust process.

Solution: Replace the water pump. Thoroughly flush the cooling system before installing the new pump and refill the system with the correct vehicle manufacturer's recommended coolant (see also pages 10-11 and 50-52). Inspect the pressure cap (see also pages 35-36) and replace if defective.

DIAGNOSING COOLING SYSTEM PROBLEMS

4. Deposit build-up



Appearance: Deposits, sludge and scale build up on the inside, clogging the water pump and hampering proper functioning of its individual components.

Cause: Contaminated coolant, non-compatible coolant or mixing coolants of different chemistries.

Solution: Replace the water pump. Thoroughly flush the cooling system before installing the new pump and refill the system with the correct vehicle manufacturer's recommended coolant (see also pages 10-11 and 50-52).

5. Cavitation



Appearance: Vapour cavities ("bubbles") in the coolant collapse with explosive force, pockmarking the pump's individual components. The pockmarked areas then corrode away.

Cause: Cavitation occurs depending on the thermodynamic conditions of temperature and pressure encountered. These conditions can lead to the formation of bubbles at the coolant inlet of the pump. As the pressure increases in the system, the bubbles implode and cause harm.

Solution: Replace the water pump. Thoroughly flush the cooling system before installing the new pump and refill the system with the correct vehicle manufacturer's recommended coolant (see also pages 10-11 and 50-52).

6. Damaged bearing



Appearance: With the engine off, check the condition of the bearing by looking for any side-to-side play at the shaft. Apply hand pressure – there should be no play at all. Also, rumbling or screeching noises coming from the water pump indicate a worn bearing.

Cause: Misalignment: a misaligned belt causes excessive wear. Excessive belt tension: an over-tensioned belt causes overload on the bearing which accelerates wear. Failed mechanical seal: when the seal is damaged, it allows coolant to leak through the bearings and wash away the lubricator. Also, never compromise on water pump quality. Cheap water pumps do not follow the OE prescriptions in terms of mechanical seal and bearing quality.

Solution: Replace the water pump and make sure to inspect the belt drive system: belt, tensioner, pulleys, belt tension and alignment.



DIAGNOSING COOLING SYSTEM PROBLEMS

7. Damaged or broken shaft



Appearance: The shaft is bent or in some cases even broken. A clean fracture through the front bearing race part of the shaft means the water pump was subjected to a sudden overload or imbalance caused by heavy vibration. If the broken shaft is discoloured (usually blue), the damage was gradual, indicating excessive heat build-up before the shaft broke.

Cause: Misalignment: a misaligned belt causes excessive wear. Excessive belt tension: an over-tensioned belt imposes a powerful bending force on the shaft causing it to deflect substantially from true centre rotation resulting in shaft bending or early shaft fracture. Excessive vibrations due to lack of maintenance.

Solution: Replace the water pump and make sure to inspect the belt drive system: belt, tensioner, pulleys, belt tension and alignment. If equipped with a water pump mounted fan, inspect the fan/fan clutch assembly. The fan may not be squarely mounted on the shaft. A bent or damaged fan, a worn spacer, or a worn or damaged fan clutch could also be factors contributing to the break.

Inspecting the radiator, the expansion tank and their caps

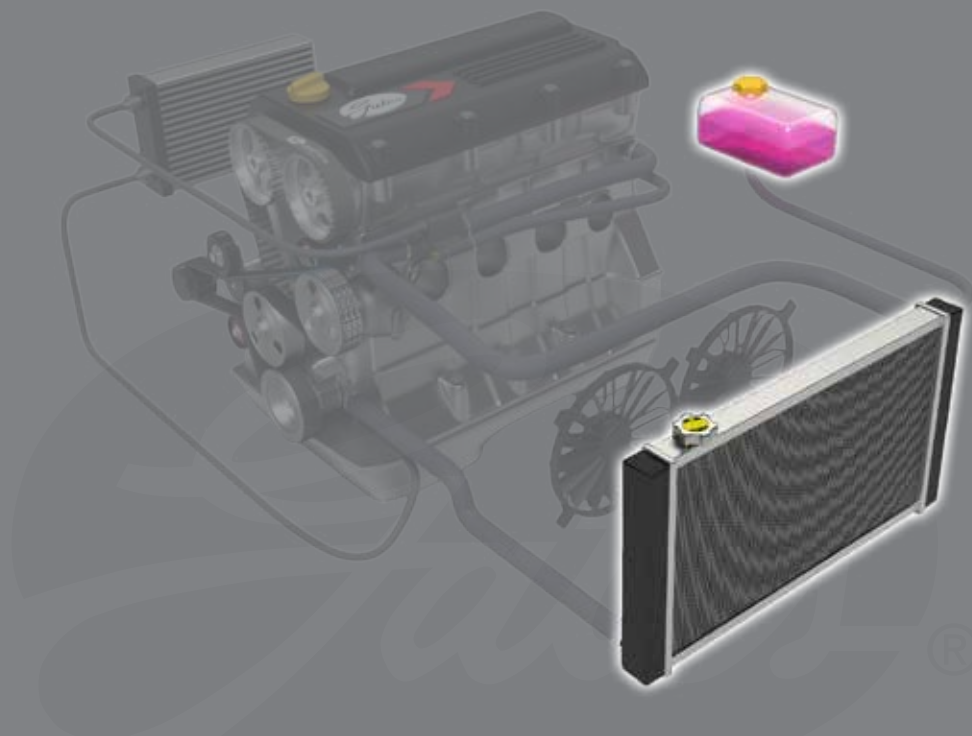

With this troubleshooting guide, Gates aim is to advise how to properly inspect and replace the cooling system's wear parts. Although focus is not on the system's hard parts, some general troubleshooting information on both the radiator and expansion tank is included, as these parts form a unit with the radiator cap and the expansion tank cap. In terms of system design, a distinction is made between systems that are equipped with a conventional radiator with a coolant box on one or on both ends and systems that have an individual expansion tank which is the most common in modern vehicles. For more detailed instructions pertaining to your specific radiator/expansion tank, consult the vehicle manufacturer's recommended procedures.

DIAGNOSING COOLING SYSTEM PROBLEMS



Some basics on the radiator

The radiator is installed in the air flow at the front of the vehicle. Its role in the cooling system is to release the combustion waste heat absorbed by the coolant to the outside air. Radiators are constructed with small metal tubes to carry the coolant and small fins to increase the surface area for air to flow over and optimise heat dissipation.

It is important that the radiator is free of debris to maintain a free flow of air across the fins. A radiator can also become clogged internally with deposits, reducing or even blocking the coolant flow. Corrosion and vibrations are other enemies of the radiator, damaging its individual components or causing leaks. The following list will help you troubleshoot radiator problems:

- › Changing the coolant every two years is the best preventive maintenance for the radiator.
- › Check the radiator after every, even the smallest, impact on the front of the car.
- › Pressure test the radiator for leaks. (Use the Cooling System Pressure Tester Part #: 12270 available from Gates).
- › Check the radiator for exterior soiling and clean it if necessary. Do not get too close to the radiator lamellas and fins when using pressurised liquid.
- › Check the radiator for external damage and corrosion.
- › Check the coolant flow (blockage through foreign materials).
- › Check the radiator cap (see next page for more detailed information).



Some basics on the expansion tank

There are two types of expansion tanks found on modern vehicles. Some are connected to the cooling circuit via a single hose, others are placed in the circuit with one hose leading into the tank and one hose leading out from the tank. Their location under the bonnet also varies: in some cases they are built in next to the radiator, in others they are more remotely located. Although expansion tanks differ in design and location, they all do the same thing. They store the coolant reserve and hold expanded coolant from the cooling circuit. High coolant temperature results in a rising pressure in the cooling system, because hot coolant expands in volume. Coolant is pressed into the tank. When coolant temperature drops again, coolant is recovered from the tank. In other words, the expansion tank accommodates the changes in coolant volume as the coolant goes through its cycle of heating up (expanding in volume) and cooling down (reducing in volume). Expansion tanks are typically made of transparent plastic to allow the coolant level to be checked, and commonly have 'minimum' and 'maximum' marks.

Expansion tank failures are usually a result of cracks, bursts or leaks in the tank itself or of a failed expansion tank cap (see next page for more detailed information).



Hardly noticed, but important: the radiator cap and the expansion tank cap

The radiator cap is a very important part of the engine's cooling system, yet it is often overlooked when troubleshooting the system. If an individual expansion tank is installed, which is mostly the case today, the expansion tank cap is equally important. The radiator cap and expansion tank cap make sure the filling hole of the radiator and expansion tank are sealed off gastight. But they do a lot more than just that.

Understanding cap technology

Caps are designed to ensure that the prescribed pressure on the cooling system is maintained at all times during operation by allowing air to escape in case of overpressure. They should therefore be considered "the safety valve" of the cooling system. The cooling system is pressurised because adding pressure on the coolant raises the boiling point of the coolant, or in other words, makes the system more resistant to boiling and therefore perform better. Boiling is to be avoided at all times because it creates air bubbles in the circuit. Air bubbles considerably reduce the circulation of the coolant and may lead to engine overheating.

Let us clarify how a cap functions exactly. When coolant heats up, it expands in volume. The expanding fluid gets "pressed" causing the pressure in the cooling circuit to rise. For this purpose, the cap is equipped with a pressure relief valve. When the pressure reaches a set value (bar/psi), the pressure relief valve in the cap opens, relieving the excessive pressure by letting air vent through the cap. The expansion tank traps the expanded coolant. When coolant cools down, it contracts, which would create a vacuum in hermetically sealed systems. For this purpose, the cap is equipped with a vacuum relief valve. Coolant is sucked back into the cooling circuit to maintain the proper coolant level. This also generates a vacuum in the expansion tank. Consequently, the vacuum relief valve opens, allowing air to flow into the tank until the pressure is equalised. ®

Understanding cap terminology: vented versus non-vented

There are only two basic types of caps but many ways to describe them. Caps that are equipped with a pressure relief and a vacuum relief valve are most commonly described as "vented caps" whereas "non-vented caps" are plain and simple caps without special functionality valves. Some vehicles have a vented cap on the radiator to ensure the system pressure is kept at a safe set value, or the maximum allowable pressure, at all times. In that case, the cap on the expansion tank will be non-vented. In other vehicles the expansion tank serves as a pressurised part of the cooling system, e.g. in the case where the radiator lacks a coolant filling hole and the expansion tank serves as the filling point. In that case, the vented cap will be on the expansion tank instead of on the radiator.

Special note: A lever on the top of the cap does not make it a vented cap

Under the top of the shell, every cap has an upper main seal that seals against the filling hole or the top of the filler neck. But only a vented cap will have two additional seals at the bottom of the cap: the pressure relief valve with pressure seal against the base of the filler neck, and the vacuum relief valve (brass or stainless circle plate) with return seal centred in the pressure relief valve.

DIAGNOSING COOLING SYSTEM PROBLEMS

Identifying a worn cap

Caps consist of many different small parts that can fail independently of each other. The main seal must be in excellent condition for the cap to seal tightly. If cracked, age-hardened or damaged, pressure and coolant can escape. A failed pressure relief valve will cause the coolant to boil at a lower temperature. If the pressure valve spring fails, the pressure seal won't be pushed back into place. A failed vacuum relief valve will leave a vacuum in the system that will attack the weakest point in the circuit – in this case the hose – which will collapse. Even a new hose can go flat with a bad cap. See page 36 for tips on a cap function check.

Facts to know about cap replacement

A damaged cap cannot effectively seal off the system nor keep it properly pressurised which will compromise the proper functioning of the cooling system. So, when performing routine cooling system maintenance or repairs or troubleshooting an overheating or loss of coolant problem, make sure to inspect the caps and replace any that are defective.

If there is ever any doubt, best practice is to replace the cap. It doesn't cost you a lot in labour and time, but will keep your customer's car in the best shape, raising the customer satisfaction levels for your garage.

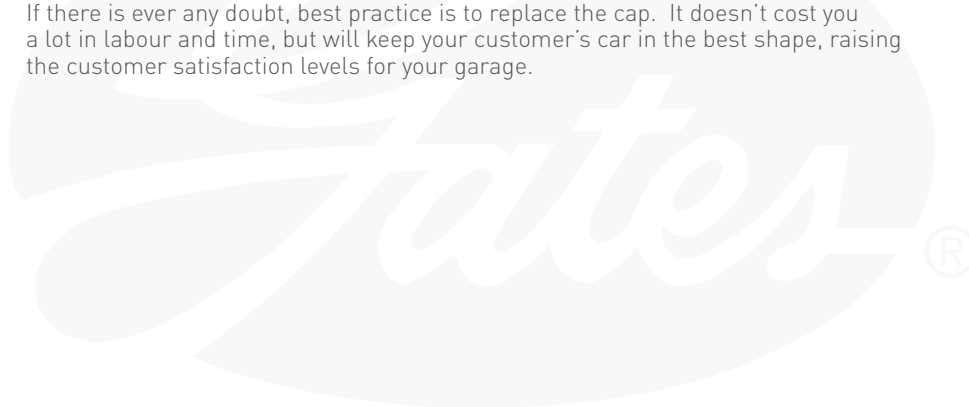

Cap function check

Follow these steps to help you identify a faulty cap:

Never remove a cap when the engine is still hot!



- > Look up the pressure rating specified for the vehicle and compare it with the pressure rating printed on the cap. If incorrect, replace the cap.
- > Visually inspect the condition of the main seal, pressure seal and return seal. Replace the cap if the seals are cracked, hardened or damaged.
- > Both the pressure relief and vacuum relief valve must be easy to lift and spring back after release. If not, replace the cap.
- > There must be resistance on the spring. If there is none, the spring has lost its force and the cap needs to be replaced.
- > Pressure test the cap with a professional pressure testing device (follow manufacturer's instruction). If the cap fails to hold the rated pressure, replace the cap. (Use the Cooling System Pressure Tester Part #: 12270 available from Gates)
- > Always check the radiator/expansion tank when replacing a faulty cap. It may have caused a dangerous build-up of overpressure causing bursts or cracks which ultimately lead to leakage.

TROUBLESHOOTING GUIDE



REPLACE WORN PARTS WITH PREMIUM PRODUCTS BY GATES

GATES, YOUR ONE-STOP-SHOP FOR ALL COOLING SYSTEM SERVICE PARTS

You know Gates as the drive system specialist. But it should be clear by now that Gates is in fact also one of Australia and New Zealand's leading suppliers of cooling system components and a true cooling system expert.

You can rely on Gates cooling system parts for OE quality and a perfect fit and adding to that we supply unrivalled aftermarket support. Offering you the biggest added value through superior, reliable products, full service, specialist tools and in-depth expert training, Gates has everything you need to tackle the challenges you are faced with.

Gates gives you top-quality cooling system components to service your customers' cars. And we back up every product we sell with the most up-to-date cataloguing, technical support and training, warranty programmes you will find anywhere!

REPLACE WORN PARTS WITH PREMIUM PRODUCTS BY GATES



Gates coolant hoses are exactly what hot, tight engines spaces need

Today's smaller engines are increasingly more powerful, creating more heat and leaving less space under the bonnet. With the reduction in engine compartment size, coolant hoses must fight ever-higher temperatures and come in ever-more shapes and sizes to fit specific applications and tight engine spaces. In addition to that, electrochemical degradation (the electrochemical attack on the tube compound on the inside of the hose, see also page 14) has been identified as the number one cause of hose failure. This demonstrates the importance of choosing coolant hoses that are electrochemical resistant.

Facts about Gates coolant hoses

Gates customers appreciate the wide variety of choices our OE-quality coolant hose range offers. It includes curved, flexible, straight and small ID (inside diameter) hoses covering upper, lower, by-pass, heater and other coolant transfer applications. Plus, Gates has coolant hoses in its range that are electrochemical resistant (ECR), resisting the negative effects of electrochemical degradation.

The benefits of Gates coolant hoses include:

Radiator hose

Curved (factory-moulded) hose

- › Engineered to resist electrochemical degradation
- › Pre-shaped to fit specific applications (application-based)
- › Also available in symmetrical 90° curved hose
- › Easy to install and to cut to size: pre-printed cut-off marks show where to cut the hose so it can fit more than just one application
- › Resistant to heat and ozone
- › Meets SAE 20R4 class D2 and DIN 73411 class A specifications

Vulco-Flex® II hose

- › Highly flexible to be bent into various shapes and fit many applications
- › With built-in reinforcing helical wire preventing the hose from collapsing when bent
- › Resistant to heat and ozone
- › Meets SAE 20R5 class D2 specifications

Wire-inserted Green Stripe® hose

- › Engineered to resist electrochemical degradation
- › Medium flexible (allows bending to medium bend radius)
- › With built-in reinforcing helical wire preventing the hose from collapsing when bent
- › With heavy-duty fabric reinforcement
- › Resistant to heat, ozone, grease and oil
- › Meets SAE 20R5 class C specifications

Heater hose

- › Engineered to resist electrochemical degradation
- › Medium flexible (allows bending to medium bend radius)
- › Resistant to heat and ozone
- › Meets DIN 73411 class A specifications

Silicone hose

- › On top of that, Gates offers several radiator and heater hoses made of first grade silicone material for outstanding resistance to extreme temperatures

Heater hose connectors

- › 36 different straight, elbow, "T" and reducer hose connectors
- › All in one handy plastic case

Remember that not all hoses are created equal. Quality is determined by the resistance properties built into it!

REPLACE WORN PARTS WITH PREMIUM PRODUCTS BY GATES

Guidelines for replacing hoses

Remember! These are only general guidelines. Always refer to the vehicle manufacturer's recommended procedures for replacement and maintenance of coolant hoses. Failure to follow these instructions could result in injury or property damage. Gates disclaims all liability due to failure to follow these instructions.

.....

STEP 1 - Safety first

Always wait until the engine is cool before working on any part of the cooling system.

.....

STEP 2 - Loosen the clamp and remove the old hose

Use tool for removing and installing hose clamps and clips.

Most hoses should gently twist off the fitting once the clamp is loosened.

A rusted clamp can be carefully cut and removed with tin snips.

If the hose is stuck to the fitting, do not force or pry it off. Doing so could damage the fitting. Instead, carefully cut the hose lengthwise, then peel the hose off the fitting.

.....

STEP 3 - Check the nipple for sharp edges or burrs

It is best to clean the fitting with a wire brush to make sure it is clean and smooth.

.....

STEP 4 - Inspect the thermostat, water pump and pressure cap(s)

Before installing the new hose, inspect the other cooling system service parts – as described earlier in this manual.

.....

STEP 5 - Install a new Gates hose

Slip the new clamp onto the hose and then push the hose onto the fitting, installing the engine end first. Lubricating the nipple with a small amount of washing-up liquid will make it easier to push the hose onto the fitting, without affecting the hose quality.

Check that the hose is shouldered well beyond the edge of the fitting.

Caution: hose clamps come in very different types, each designed to meet different hose specifications so make sure you install the correct style and size of clamps.

.....

STEP 6 - Proceed and tighten the new hose clamps

Clamp the hose into position between the nipple and the hose end. Caution: a clamp tightened over the nipple will eventually cut the hose tube.

.....

STEP 7 - Do a final visual inspection to ensure there are no leaks after the cooling system refill

Keep in mind that some leaks will become obvious when the engine is cold, but others only when it is hot.

.....

Special note

In some cases, if the hose is not an exact original equipment duplicate, slight twisting or bending of the hose may be required for proper installation. This will not damage the hose as long as it does not kink or collapse.

.....

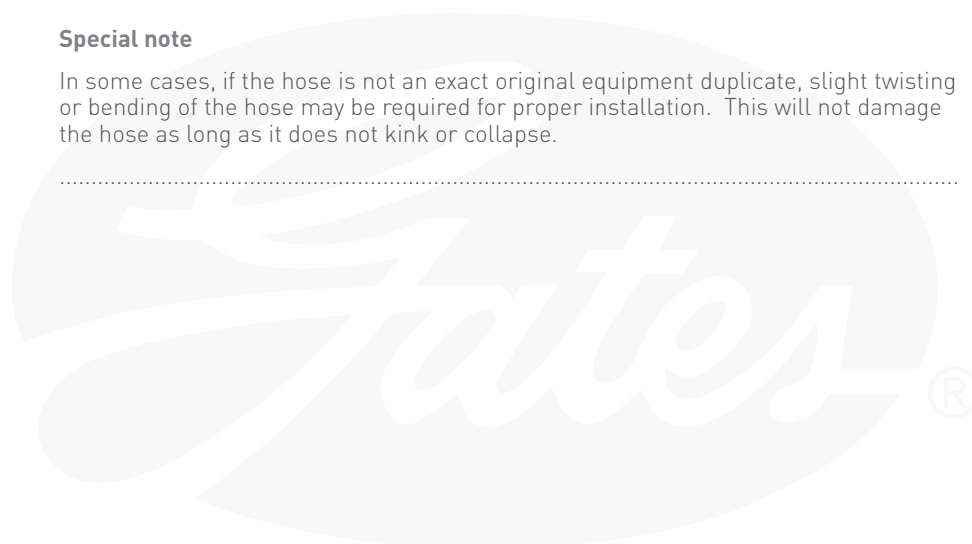

REPLACE WORN PARTS WITH PREMIUM PRODUCTS BY GATES



Stant® thermostats for a highly accurate coolant temperature control

Thermostats come in several different types but basically all do the same thing: they regulate the coolant flow through the radiator to obtain and maintain the optimum engine operating temperature. But do you realise that by doing so a “trivial” component such as the thermostat actually helps the engine to operate at its highest efficiency and hence contributes to substantial fuel economies and lower emissions? There is only one condition: it must be highly accurate (and of course in perfect operating condition).

Facts about Gates thermostats

Stant® offers OE-quality thermostats that do exactly that: accurately regulating the coolant flow. The majority of vehicles on the road today have traditional thermostats. The heart of the Gates traditional thermostat is the temperature-sensitive wax element. A specifically formulated, thermally-expansive wax is calibrated to assure prompt and accurate operation of the thermostat valve. Warming the wax element increases the volume of the wax, thereby moving the piston and opening the valve. If the temperature drops, the volume is reduced, and a spring pushes the piston back to the starting position. Simple, effective, and tried and tested millions of times over.

As Gates invests heavily to ensure its offering reflects OE trends, you can find a growing number of map-controlled thermostats in our range. Gates map-controlled thermostats have an electric heating resistor integrated into their wax element. In the event of specific engine load conditions electrical heating of their wax element is triggered by the engine electronics control unit. In other words, the engine electronics control unit simulates a higher coolant temperature preventatively in the event of a corresponding capacity demand, even though the temperature has not actually risen yet. This additional heat source allows for an even more accurate engine warm-up and a continuous adjustment of the coolant temperature to the current driving situation.



The benefits of Stant® thermostats include:

- › OE technology and trends
- › Matching seals and gaskets also available
- › Wide selection available: thermostat inserts, regular thermostats, housing thermostats, map-controlled thermostats, reverse poppet thermostats, offset thermostats with jiggle pin valves, bypass thermostats and many more

Guidelines for replacing thermostats

Remember! These are only general guidelines. Always refer to the vehicle manufacturer's recommended procedures for replacement and maintenance of thermostats. Failure to follow these instructions could result in injury or property damage. Gates disclaims all liability due to failure to follow these instructions.

STEP 1 - Safety first

Always wait until the engine is cool before working on any part of the cooling system.

STEP 2 - Remove the hose attached to the thermostat

Be aware that a considerable amount of coolant can pour out of the hose when you take it off.

STEP 3 - Look at how the thermostat is positioned

Before proceeding, make sure you are familiar with the configuration and remember to put the new thermostat back the same way.

STEP 4 - Loosen the bolts and remove the old thermostat

STEP 5 - Remove the old seal/gasket or old sealant remains and make sure the mounting surface is clean

STEP 6 - Inspect the coolant hoses, water pump and pressure cap(s)

Before installing the new thermostat, inspect the other cooling system service parts – as described earlier in this manual.

STEP 7 - Install a new Gates thermostat

Install the new thermostat so the copper heat-sensing element is toward the coolant flow coming from the engine. If installed upside down, it won't function.

Old gaskets and seals should be replaced by new ones. Carefully follow installation instructions. Only apply sealant if specifically recommended by the vehicle manufacturer. Put an even bead of sealant along the edge of the part, but don't use too much sealant. If you do get too much sealant on the part, wipe off the excess before mounting the new thermostat. Too much sealant compromises the correct installation and will break off within the cooling system, contaminating it. Sealants are also made with different drying rates, so respect the sealant's printed instructions.

STEP 8 - Tighten the bolts evenly to the manufacturer's torque specifications

STEP 9 - Re-attach the hose

STEP 10 - Do a final visual inspection to ensure there are no leaks after the cooling system refill

Keep in mind that some leaks will become obvious when the engine is cold, but others only when it is hot.

REPLACE WORN PARTS WITH PREMIUM PRODUCTS BY GATES



Gates Timing Component Kit with Water Pump offer you high customer satisfaction levels

The water pump plays a critical role in the cooling system as it makes sure the coolant is continuously circulated throughout the entire cooling circuit. Put differently, if the pump fails the coolant simply stops moving. The vast majority of today's car parc has a timing-belt-driven water pump and in that respect it is particularly important not to overlook the relationship between the water pump and the synchronous belt drive system. A faulty timing belt or tensioner will cause the water pump to cease; the same as a leaking water pump will cause the belt and tensioner to fail prematurely. Good technicians therefore always use a water pump kit for a complete overhaul of the synchronous belt drive system to ensure their customers receive the best service.

Facts about Gates Timing Component Kit with Water Pump

Gates water pumps are included in the all-in-one Gates Timing Component Kits with Water Pump Kits. With these kits, you get all the parts necessary for a complete system overhaul in one box: the Gates OE timing belt(s), OE metals, bolts/springs as well as the Gates application-specific OE-quality water pump with the required seals/gaskets. All Gates water pumps are fitted with a precisely balanced impeller to ensure OE fit and function, and are subjected to a functional test of seals and bearings along with a leakage test.

The benefits of Gates Timing Component Kit with Water Pump include:

- › Genuine OE components: all matched to work perfectly together
- › Best range: continuously expanding to ensure biggest car parc coverage
- › Easy sourcing: you only need to order one part number
- › Time and cost benefit: the time it takes to fit a timing belt kit is the same, whether the water pump is replaced or not. Choosing not to replace the water pump at the same time as the belt is to assume that the water pump will last for another complete duty cycle of a new belt. Replace the water pump and your customers only need to visit once for a system change without the need to return with a subsequent water pump failure
- › Loyal customers: satisfied customers become loyal to "their workshop"

Guidelines for replacing water pumps

Since Gates recommends replacing the water pump, belt and other drive components at the same time, we want to give you an idea of which steps need to be taken in a job of this type. Different engine designs use various belt drive system configurations, so always check the vehicle manufacturer's maintenance manual for specific instructions.

Remember! These are only general guidelines. Always refer to the vehicle manufacturer's recommended procedures for replacement and maintenance of water pumps. Failure to follow these instructions could result in injury or property damage. Gates disclaims all liability due to failure to follow these instructions.

**Never dry run a water pump, not even for a few seconds.
Dry running of the pump ruins its internal mechanical seal!**

Coolant has a specific role as it relates to the pump's mechanical seal. To keep the pump's rotating seal faces from overheating and failing, the mechanical seal must constantly be "wetted" by coolant. Therefore, always rotate a newly installed pump a few times by hand after system refill to make sure a small amount of coolant passes the mechanical seal before the engine is started.

STEP 1 - Safety first

Always wait until the engine is cool before working on any part of the cooling system.

STEP 2 - Remove the belt drive components following the vehicle manufacturer's recommended procedures

STEP 3 - Remove the hose attached to the water pump

Be aware that a considerable amount of coolant can pour out of the hose when you take it off.

STEP 4 - Loosen the bolts and remove the old water pump

STEP 5 - Remove the old seal/gasket or old sealant remains and make sure the mounting surface is clean

STEP 6 - Inspect the coolant hoses, thermostat and pressure cap(s)

Before installing the new water pump, inspect the other cooling system service parts – as described earlier in this manual.

REPLACE WORN PARTS WITH PREMIUM PRODUCTS BY GATES

STEP 7 - Install a new water pump

Do not force the pump on by striking the pump shaft.

Old gaskets and seals should be replaced by new ones. Carefully follow installation instructions. Only apply sealant if specifically recommended by the vehicle manufacturer. Put an even bead of sealant along the edge of the part, but don't use too much sealant. If you do get too much sealant on the part, wipe off the excess before mounting the new water pump. Too much sealant compromises the correct installation and will break off within the cooling system, contaminating it. Sealants are also made with different drying rates, so respect the sealant's printed instructions.

.....

STEP 8 - Tighten the bolts evenly to the manufacturer's torque specifications

.....

STEP 9 - Re-attach the hose

.....

STEP 10 - Refill the cooling system with the correct vehicle manufacturer's recommended coolant

.....

STEP 11 - Manually rotate the pump and make sure it rotates freely

.....

STEP 12 - Make sure the belt drive system that will drive the new water pump is in perfect condition and installed following the vehicle manufacturer's recommended procedures

The belt drive system works hand in hand with the water pump – as described earlier in this manual. That is why according to Gates changing the water pump, belt and other drive components at the same time is good preventive maintenance.

.....

STEP 13 - Do a final visual inspection to ensure there are no leaks after the cooling system refill

When a water pump is new, some seepage from the weep hole is normal as it takes about ten minutes of operation for the pump's internal mechanical seal to properly seat itself (break-in period). More pronounced seepage and drips from the weep hole after this break-in period or leakage from the mounting surface are abnormal and signal part failure or faulty installation.

Keep in mind that some leaks will become obvious when the engine is cold, but others only when it is hot.

.....



**Gates radiator and expansion tank caps
increase cooling system efficiency**

The importance of the radiator and expansion tank cap within a cooling system often goes unrecognised, yet they are fundamental components. These caps do a lot more than just fulfil the function of closing the filling hole of the radiator or the expansion tank gastight. They also ensure that the prescribed pressure on the system is maintained at all times during operation by allowing air to escape in case of overpressure. Therefore, they are one of the smallest but important parts in keeping your customer car's cooling system operating efficiently.

The benefits of Gates radiator and expansion tank caps include:

- › Full range of caps available: metal radiator caps from the very smallest to the large-diameter type both long reach and short reach, and plastic expansion tank caps
- › No adjustment for installation required
- › Tight closing
- › Precise pressure control

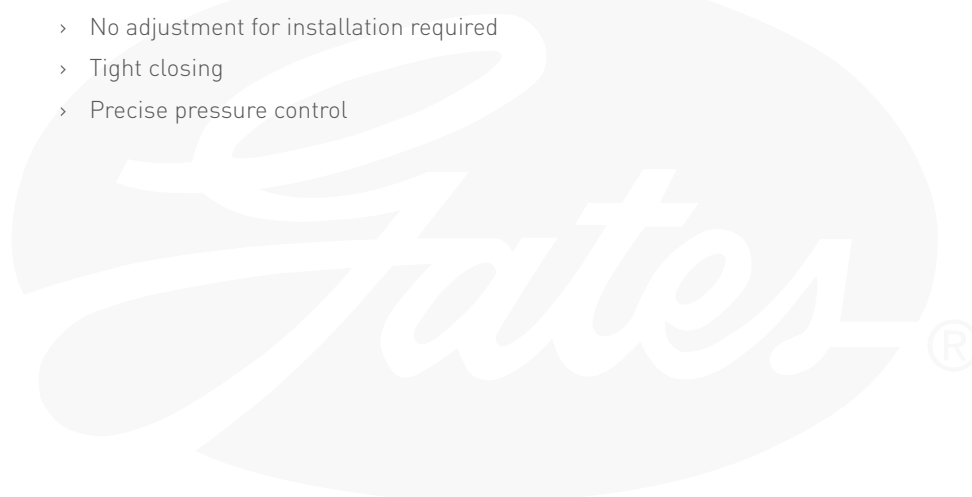

REPLACE WORN PARTS WITH PREMIUM PRODUCTS BY GATES



Gates Power Clean™ Flush Tool (Part #: 91002) for in-depth cleaning of the cooling system

Over time, the protectants in coolant become depleted and lose their effectiveness and the coolant can get contaminated with traces of oil, dirt and other harmful particles (see also pages 10-11). As a result, the cooling system needs to be properly maintained by flushing. It is important to periodically flush the complete cooling system including the radiator, engine block and heater core. A complete flush is also critical before changing cooling system service parts.

Cooling systems can be difficult to flush completely due to severe accumulated debris. Inadequate flushing can lead to premature failure of a newly installed component, which can void manufacturer warranty. To help eliminate these problems technicians are faced with, Gates developed the Power Clean™ Flush Tool which uses pulsating technology to ensure a complete and thorough system flush.

Using clean water and compressed air, the Gates Power Clean™ Flush Tool safely removes accumulated debris and contaminants without the use of harsh chemicals or solvents. A complete set of tips and connectors allows the tool to be used on radiator necks, engine blocks and heater core tubes. The tool's process allows air to pressurise the water to scrub deep into corners and crevices, removing trapped debris, and it automatically regulates the pressure to a safe level if a hard blockage exists, eliminating the possibility of damage to the system.

The Gates Power Clean™ Flush Tool offers technicians an alternate way to properly care for the cooling system of any vehicle make and model, reducing warranty claims and comebacks.

Just think of how many comebacks you can avoid by using the Gates Power Clean™ Flush Tool!

The Gates Power Clean™ Flush Tool flushes the cooling system completely and thoroughly, while other methods leave unacceptable levels of debris and contaminants in the system!

SPECIAL CASE: HOW TO PROPERLY DRAIN, FLUSH AND REFILL THE COOLING SYSTEM

Proper draining, flushing and refilling of the cooling system ensure optimum cooling system operation, increased engine efficiency and high customer satisfaction levels. Following guidelines will help you to correctly drain, flush and refill the cooling system.

Remember! These are only general guidelines. Always refer to the vehicle manufacturer's recommended procedures. Failure to follow these instructions could result in injury or property damage. Gates disclaims all liability due to failure to follow these instructions.

Draining the old coolant

STEP 1 - Safety first

Always wait until the engine is cool before working on any part of the cooling system.

STEP 2 - Press down on the radiator cap, slowly turn it counter-clockwise until it hisses, wait until the hissing stops and then remove the cap

STEP 3 - Place a large container under the drain valve at the bottom of the radiator

Check the vehicle service manual to locate all of the coolant drain valves in the engine block and cooling system.

STEP 4 - Loosen the drain valve and allow the coolant to completely drain out

If the radiator does not have a drain valve, disconnect the lower radiator hose and allow the coolant to drain out.

If the vehicle is equipped with an individual expansion tank, disconnect all hoses connecting it to the cooling circuit and allow the coolant to drain out.

STEP 5 - Think about the environment and properly dispose of the old coolant

REPLACE WORN PARTS WITH PREMIUM PRODUCTS BY GATES

Flushing the system

In case of part replacements, make sure the flush is completed with the old components still in place!

Flushing after the new components are installed can lead to premature failure due to abrasive particles and debris negatively impacting the new components.

STEP 6 - Read the Gates Power Clean™ Flush Tool user instructions completely before you begin and follow them carefully

STEP 7 - Prepare the vehicle for the flush

Radiator: remove lower radiator hose, upper radiator hose, and if possible, completely remove the drain valve to allow for debris outflow from the lowest point of the radiator.

Engine block: remove lower radiator hose, upper radiator hose and thermostat.

Heater core: the heater control valve must be verified to be open before attempting to flush through the valve. If this cannot be verified then it should be removed.

STEP 8 - Install the accessory best suited for the respective flush job and flush as much as needed until the radiator/engine block/heater core outflow is clear

A complete set of tips and connectors comes with the Gates Power Clean™ Flush Tool to make it suitable for use on radiator filler necks, engine blocks and heater core tubes.

STEP 9 - Inspect the coolant hoses, thermostat and water pump and replace them if necessary – as described earlier in this manual

Refilling the system

STEP 10 - Retighten the drain valve at the bottom of the radiator

Make sure all the hoses are properly reconnected.

STEP 11 - Refill the cooling system with the correct vehicle manufacturer's recommended coolant, ensuring that the cooling system is bled following vehicle manufacturer instructions

The moment the cooling system is drained, air replaces the coolant. When the system is refilled, air can get trapped in the cooling circuit. Air in the system is to be avoided at all times. Air bubbles considerably reduce the circulation of the coolant and may lead to engine overheating. They also accelerate the rust process, shortening the life of the system. Some systems are equipped with a bleeding valve on the upper radiator hose that allows trapped air to escape from the system. Other systems require that the expansion tank is dismounted/pulled upwards to vent the trapped air. Therefore, Gates recommends to always check the vehicle service manual for the prescribed bleeding procedure.

STEP 12 - Inspect the radiator cap and expansion tank cap (if applicable) and replace them if necessary – as described earlier in this manual

STEP 13 - With the engine at operating temperature, recheck the coolant level and top up after engine cool down if required

STEP 14 - Do a final visual inspection to ensure there are no leaks

Keep in mind that some leaks will become obvious when the engine is cold, but others only when it is hot.



LET'S RECAP

THE IMPORTANCE OF THE SYSTEM

The cooling system is of primary importance to the engine. If the system is not working properly the engine can overheat, leading to costly repairs for your customer. But the cooling system does more than just cool the engine. It contributes to engine efficiency. Engines are designed to operate within a specific temperature range for optimum efficiency. In the time it takes to reach the optimum operating temperature a car consumes more fuel, therefore emitting more CO₂ and engine parts ultimately endure more wear. The cooling system makes sure the optimum temperature is obtained as rapidly as possible and is then kept constant, increasing the fuel economy for your customer. Although the cooling system is one of the most critical elements of engine reliability and efficiency, it is often the most neglected maintenance item for all vehicles on the road today.

It is important to consider all the components that make up the cooling system when servicing it. The coolant hoses, thermostat, water pump and even the pressure cap play a vital role in ensuring the proper functioning of the cooling system.

In addition to that, vehicle manufacturers specify scheduled coolant changes in order to maintain warranty coverage. Following the warranty period, periodic cooling system flushes and coolant changes are still recommended to maintain optimum condition of the cooling system.

A REPUTATION DEPENDS ON SATISFIED CUSTOMERS

These days, keeping expenses down gets more attention than ever. Replacements are often postponed because they aren't deemed "essential" at that particular moment. However, when you consider that the largest contributor to breakdowns is improper maintenance and taking into account the much higher cost of repair that this brings about, Gates is convinced that proper maintenance is the best way to keep cars in good shape and to keep customer satisfaction levels for your garage high:

1. Check the coolant level and make at least a visual inspection of all components whenever the bonnet of the engine is lifted

The consequences of overlooking a problem for too long could be potentially dangerous for both the engine of your customer's car and the reputation of your garage.

2. Replace when you see obvious signs of deterioration or damage

If a cooling system service part shows obvious signs of deterioration or damage, it needs to be replaced immediately.

3. Replace every four years or 100,000 km (62,000 miles) as part of preventive maintenance

If your customer's vehicle has four years or 100,000 or more kilometres of service, Gates advises replacement of all wear parts, since not every case of ageing is clearly evident in the form of a failure pattern, although it very much impairs the proper functioning of the engine nonetheless.

4. Special note

While the four-year replacement interval is a basic rule of thumb, it's not exact. Vehicles operating under severe conditions or vehicles that are not driven often may require more frequent replacements.

Great care should be taken when inspecting thermostats, since it is difficult to tell if a thermostat is ready to fail by visually inspecting it so Gates recommends servicing it preventively.

In case of a belt-driven water pump, Gates advises to replace the water pump, belt and other drive components at the same time. In this way, you get higher return on labour hours and ensure the best long-term solution, improving the customer satisfaction levels for your garage.

Don't forget the coolant: it should be changed at least every two years or at 50,000 km (31,000 miles) with the vehicle manufacturer's recommended coolant as a good preventive maintenance procedure.

Last but not least, all components should be installed according to the manufacturer's recommendations.

KEEP YOUR CUSTOMERS SATISFIED. REPLACE WORN COOLANT HOSES, THERMOSTATS, WATER PUMPS AND PRESSURE CAPS WITH PREMIUM PRODUCTS BY GATES.

LET'S RECAP

REVIEW QUIZ

1. Changing coolant every two years is good preventive maintenance, to prevent coolant depletion and contamination.

True or **false**?

2. Before installing new cooling system parts, you should

- A. drain the old coolant
- B. flush the system
- C. refill the system with the vehicle manufacturer's recommended coolant
- D. all of the above

3. In case the coolant level is at the marked minimum level, it is best to:

- A. top up the system with tap water
- B. top up the system with any available coolant
- C. top up the system with the vehicle manufacturer's recommended coolant, or if not available, distilled water
- D. leave everything as it is as the level did not drop below the minimum yet

4. You can always determine if a coolant hose is still good by merely visually inspecting it.

True or **false**?

5. It is okay to remove the clamp from the old coolant hose and reuse it on the new hose.

True or **false**?

6. A thermostat that fails in the open position can cause:

- A. increased fuel consumption
- B. higher emission levels
- C. reduced heater output
- D. all of the above

7. For best results, make sure to apply thick layers of sealant to ensure a leak-free seal.

True or **false**?

8. Seepage from the weep hole of a newly installed water pump indicates pump failure.

True or **false**?

9. The belt and tensioner are critical components that work hand in hand with the water pump. It is advisable that when replacing one of these components, you replace all.

True or **false**?

10. The only purpose of the radiator cap is to retain the coolant within the system.

True or **false**?

The answers can be found on the next page.

LET'S RECAP

1. True
2. D
3. C
4. False

The number one cause of hose failure is electrochemical degradation, an electrochemical attack on the inside of the hose. There is no way to tell from a simple visual inspection if a coolant hose has internal damage.

5. False

It is advisable to replace clamps and connectors each time a new coolant hose is installed. Hose clamps come in very different types, each designed to meet different hose specifications. It is important to make sure you have the correct style and size of hose clamps at hand when you install new hoses.

6. D
7. False

Only apply sealant if specifically recommended by the vehicle manufacturer. Put an even bead of sealant along the edge of the part, but don't use too much sealant. Too much sealant compromises the correctness and tightness of the installation and will break off within the cooling system contaminating it.

8. False

When a water pump is new, some seepage from the weep hole occurs as it takes about ten minutes of operation for the pump's internal mechanical seal to properly seat itself (break-in period). This is normal and should not be seen as a failed pump.

9. True
10. False

Radiator and expansion tank caps do a lot more than just fulfil the function of closing the filling hole of the radiator and the expansion tank gastight. They are designed to ensure that the prescribed pressure on the cooling system is maintained at all times during operation by allowing air to escape in case of overpressure.

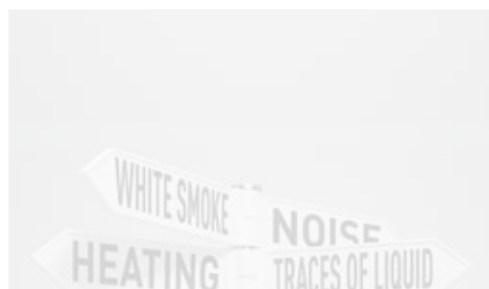

DIAGNOSE CAR PROBLEMS QUICKLY AND RELIABLY USING GATES' INTUITIVE QUESTION TREE DIAGNOSTIC PROCESS!

The easy-to-follow diagnostic tree structures will help you to quickly identify the correct cause of the problem and provide you with a logical flow to the recommended repair procedures!

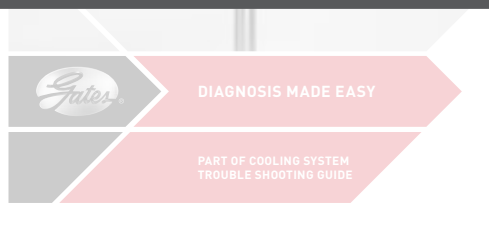

OTHER CATALOGUES AVAILABLE FROM THE GATES RANGE

Automotive Master Catalogue 496-2087

Automotive Applications Catalogue 496-2032
· DRIVE BELTS & DRIVEALIGN® COMPONENTS

Automotive Applications Catalogue 496-2043
· HOSE

Automotive Applications Catalogue 496-2015
· TIMING BELT & TIMING COMPONENT KITS

Stant Applications Catalogue 496-2048
· THERMOSTATS · GASKETS

Ideal Product Catalogue 496-2091
· CLAMPS

Automotive Applications Catalogue 496-2109
· WATER PUMPS

Trouble Shooting Manual 496-2121
ACCESSORY BELT DRIVE SYSTEM [ABDS]

©COPYRIGHT ALL RIGHTS RESERVED. THE PRODUCT AND APPLICATION INFORMATION IN THIS CATALOGUE WAS PREPARED BY GATES AUSTRALIA PTY LTD FOR THE AUSTRALIAN AND NEW ZEALAND MARKETS. GREAT CARE HAS BEEN TAKEN TO ENSURE ACCURACY AND GATES DISCLAIMS ANY LIABILITY FOR PRINTING ERRORS OR USE OF ITS PRODUCTS IN APPLICATIONS OTHER THAN THOSE FOR WHICH THEY WERE DESIGNED.

THIS CATALOGUE IS PRINTED TO ASSIST GATES CUSTOMERS. THE CATALOGUE IS SUPPLIED WITH THE CONDITION IT CANNOT BE CIRCULATED IN ANY FORM OTHER THAN IN ITS ORIGINAL FORM AND SHALL NOT BY WAY OF TRADE OR OTHERWISE BE SOLD, LENT, CIRCULATED OR REPRODUCED WITHOUT COPYRIGHT OWNERS WRITTEN CONSENT. ANY COPYRIGHT INFRINGEMENT WILL BE PROSECUTED TO THE EXTENT THE LAW ALLOWS. FOR INSTALLATION INSTRUCTIONS REFER TO APPROPRIATE VEHICLE SERVICE MANUAL.

CAUTION, USE PRODUCTS ONLY ON APPLICATIONS SPECIFIED IN GATES LITERATURE. INSTALL AND MAINTAIN PRODUCTS ACCORDING TO THE VEHICLE MANUFACTURER'S RECOMMENDED INSTRUCTIONS AND WITH RECOMMENDED TOOLS. FAILURE TO FOLLOW THESE INSTRUCTIONS COULD RESULT IN INJURY OR PROPERTY DAMAGE. GATES DISCLAIMS ALL LIABILITY DUE TO FAILURE TO FOLLOW THESE INSTRUCTIONS.



POWERING PROGRESS™



POWERING PROGRESS™

496-2122

April 2015