



Fan Relay Harness

185 Degree Thermal Switch Controlled Relay

Included Parts:

Fan Wiring Harness with Relay and Fuse Box

185 Degrees Fan Thermal Switch

Our fan wiring harness is designed for simple installation with our high performance fans. It can be installed on positive or negative ground vehicles with no modifications and is compatible with all types of vehicles.

Wiring:

Mount the relay in a secure place in the engine compartment away from heat sources. Once this is completed, connect as shown in the diagram below.

- Red: Connect to the red wire of fan pigtail with pre-terminated yellow crimp.
- Gray: Connect to the thermostat socket (sending unit) with blue ring crimp connect.
- Yellow: Connect to the positive Battery terminal using the fuse holder and yellow crimp connectors as shown in diagram (see back).
- Orange: Connect to the Ignition Switch +12 VDC for the fan to run only when engine is in run position. (hook to constant +12 VDC for the fan to run continuously when the engine is hot even when the ignition switch is off)
- Black: Connect ring Terminal to chassis ground.
- Fuse Holder: Connect fuse holder inline as shown in diagram within 12" of the battery using ring terminal or

*On medium profile single fans use a 20 amp fuse, on low profile single fans use a 15 amp fuse.

**Should your combination of fans exceed 40 amp draw, you must use two relay kits (see high current application).

Installing Thermal Switch:

The Thermal Switch has 3/8" pipe thread. The Thermal Switch supplied with the kit is an OE type that is designed to mount in the cylinder head of the engine. However, any mounting in the water jacket is suitable. The 185FH module turns on at 185 degrees and off at 165 degrees. The modules will work on the majority of applications. If a different size adapter is needed, the correct size thread adapter can be found at most automotive parts or hardware stores (1/2" adapter included in the kit). **Do not use** Teflon tape on the thermal switch as it can cause poor electrical contact and incorrect temperature readings.

Air Conditioning Relay:

Additional FRH Required. From the (second) A/C relay, connect the yellow and orange wires to the ground. Connect the red wire to the sending unit wire of the original fan relay harness. The gray wire from the A/C relay goes to the +12 volt of the A/C compressor clutch wire. The fan will turn on when the A/C compressor activates.

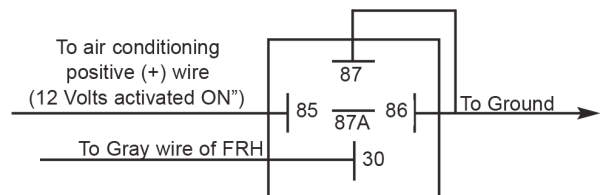

High Current Application: See multiple fan wiring diagram on reverse page.

General Information

If the vehicle has overheating problems, there can be many causes. Step one is to determine what is causing the vehicle to overheat. The chart below provides several problem, cause, and solutions to overheating.

Problem	Cause(s)	Solutions(s)
Engine overheats at idle and low speeds	Poor air flow through radiator	Install electric fan or duct air into engine compartment
	Poor engine ventilation	Install fan and make sure engine compartment can vent hot air
	Insufficient radiator	Have core cleaned or replaced with an appropriate size
	Engine idle circuit too lean	Enrich idle circuit
	Engine timing too advanced	Retard timing
Engine overheats continuously	Poor radiator/engine combination	Install sufficient radiator
	Defective or stuck thermostat	Install new thermostat

Single Fan Wiring Diagram

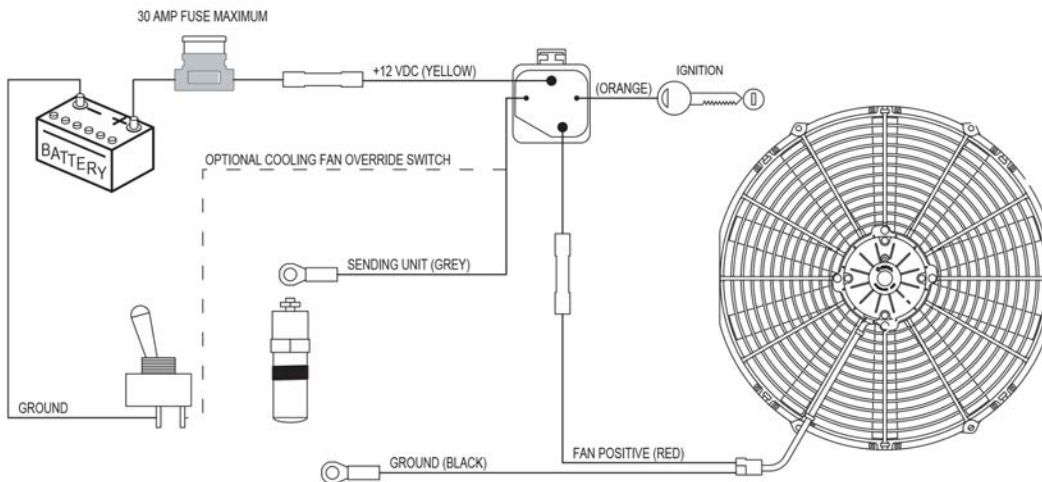

Multiple Fan Wiring Diagram

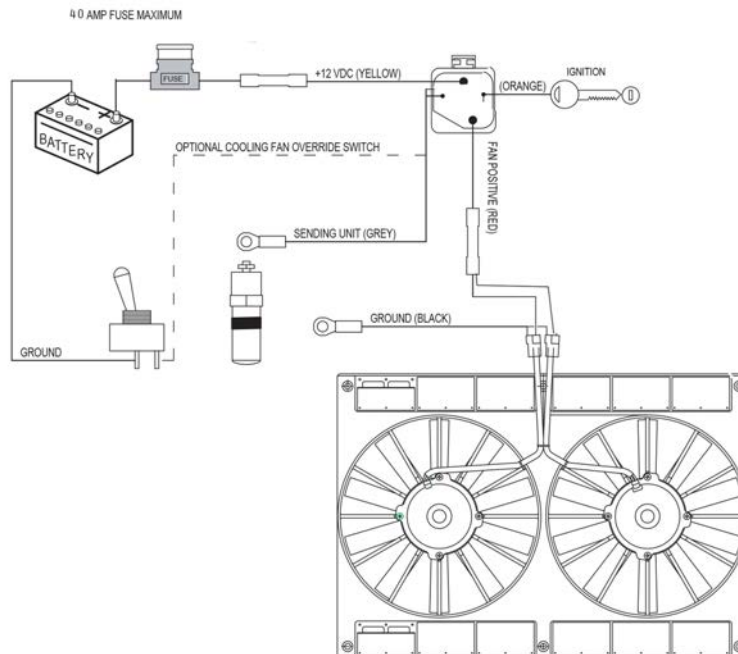

High Current Application

Multiple Fan Wiring Diagram

